

GROUP 2 SPECIFICATION

1. MAJOR COMPONENT

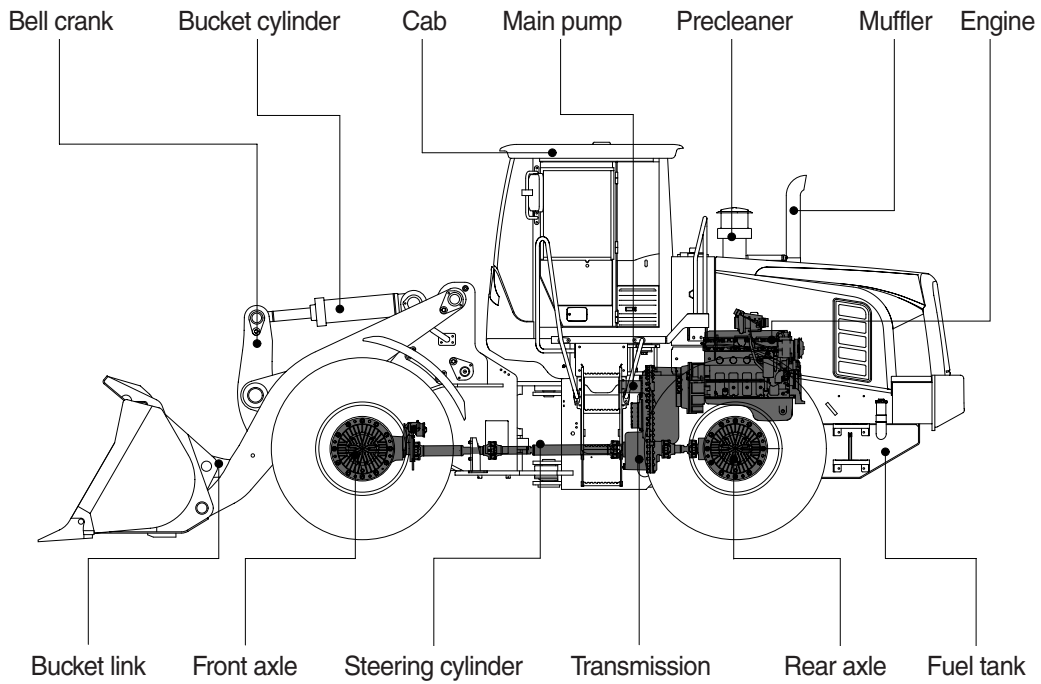
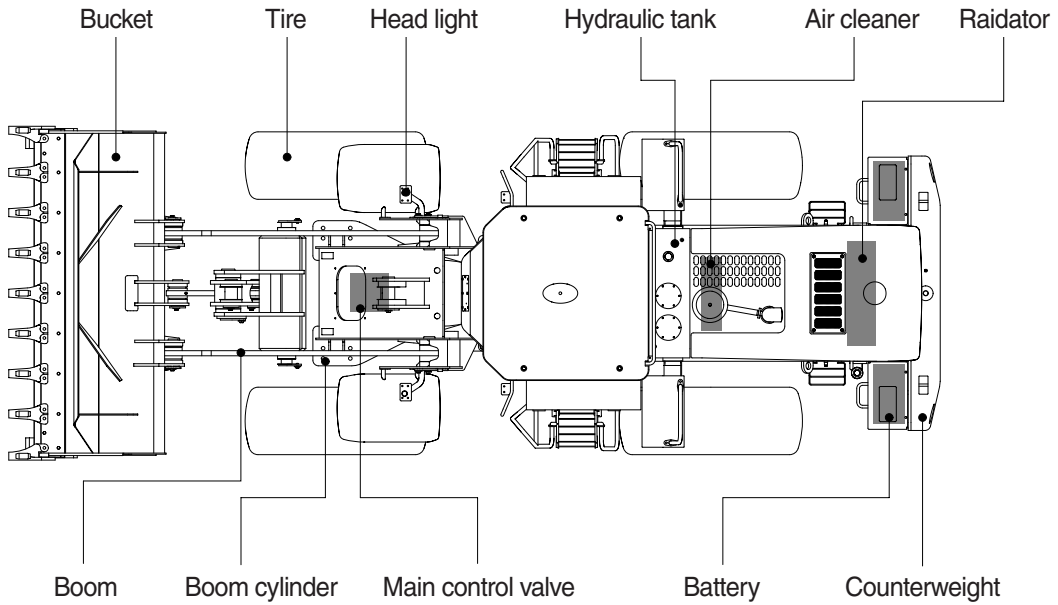

850K2SE01E

2. SPECIFICATIONS

1) WITH BOLT-ON CUTTING EDGE TYPE BUCKET

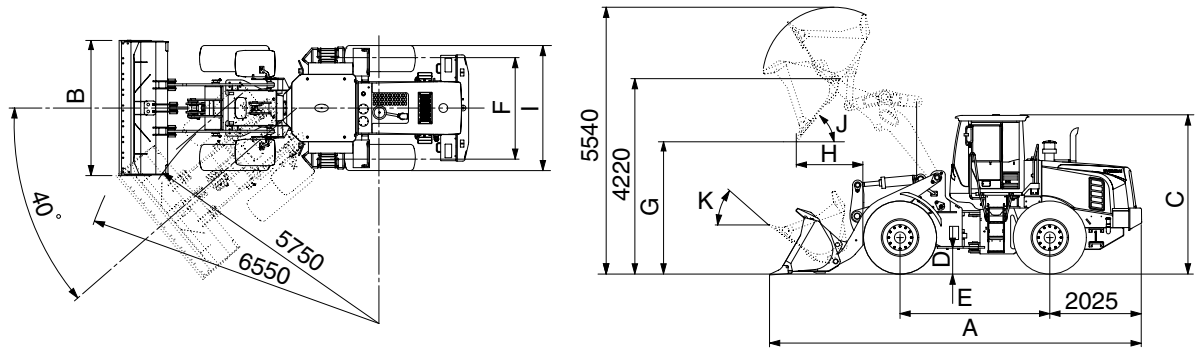

850K2SE03E

Description		Unit	Specification	
Operating weight		kg (lb)	17100 (37700)	
Bucket capacity	Struck	m ³ (yd ³)	2.7 (3.5)	
	Heaped		3.1 (4.1)	
Overall length	A	mm (ft-in)	8000 (26' 3")	
Overall width	B		2900 (9' 6")	
Overall height	C		3480 (11' 5")	
Ground clearance	D		430 (1' 5")	
Wheelbase	E		3300 (10' 10")	
Tread	F		2200 (7' 3")	
Dump clearance at 45°	G		3135 (10' 3")	
Dump reach (full lift)	H		1025 (3' 4")	
Width over tires	I		2770 (9' 1")	
Dump angle	J		degree (°)	45
Roll back angle (carry position)	K			47
Cycle time	Lift (with load)	sec	5.8	
	Dump (with load)		1.1	
	Lower (empty)		3.7	
Maximum travel speed		km/hr (mph)	38.6 (24.1)	
Braking distance		m (ft-in)	12.5 (41' 0")	
Minimum turning radius (center of outside tire)			5.75 (18' 10")	
Gradeability		degree (°)	30	
Travel speed	Forward	First gear	10.8 (6.7)	
		Second gear	38.6 (24.1)	
	Reverse	First gear	14.8 (9.2)	

2) WITH TOOTH TYPE BUCKET

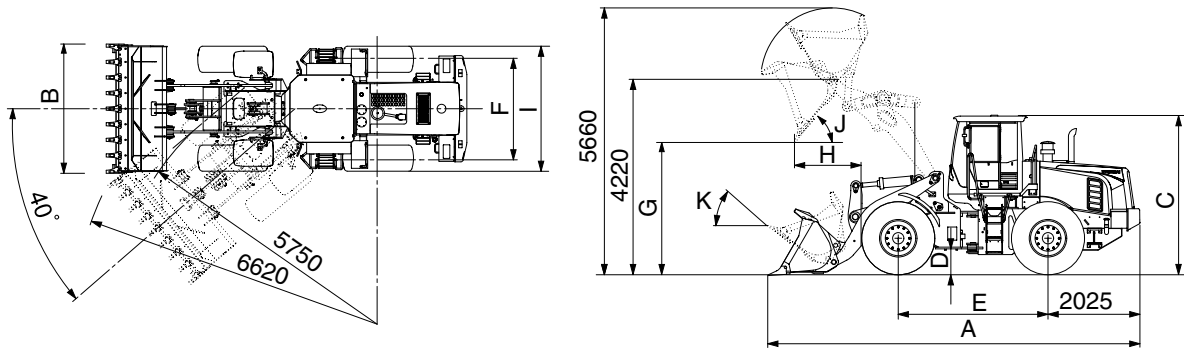

850K2SE04E

Description		Unit	Specification	
Operating weight		kg (lb)	17100 (37700)	
Bucket capacity	Struck	m ³ (yd ³)	2.6 (3.4)	
	Heaped		3.0 (3.9)	
Overall length	A	mm (ft-in)	8150 (26' 9")	
Overall width	B		2950 (9' 8")	
Overall height	C		3480 (11' 5")	
Ground clearance	D		430 (1' 5")	
Wheelbase	E		3300 (10' 10")	
Tread	F		2200 (7' 3")	
Dump clearance at 45°	G		3015 (9' 11")	
Dump reach (full lift)	H		1120 (3' 8")	
Width over tires	I		2770 (9' 1")	
Dump angle	J		degree (°)	45
Roll back angle (carry position)	K		47	
Cycle time	Lift (with load)	sec	5.8	
	Dump (with load)		1.1	
	Lower (empty)		3.7	
Maximum travel speed		km/hr (mph)	38.6 (24.1)	
Braking distance		m (ft-in)	12.5 (41' 0")	
Minimum turning radius (center of outside tire)			5.75 (18' 10")	
Gradeability		degree (°)	30	
Travel speed	Forward	First gear	10.8 (6.7)	
		Second gear	38.6 (24.1)	
	Reverse	First gear	14.8 (9.2)	

3. SPECIFICATION FOR MAJOR COMPONENTS

1) ENGINE

Item	Specification
Model	Weichai Power WD10G220E2
Type	4-cycle turbocharged diesel engine.
Control type	Mechanical control
Cooling method	Water cooling
Number of cylinders and arrangement	6 cylinders, in-line
Firing order	1-5-3-6-2-4
Combustion chamber type	Direct injection type
Cylinder bore × stroke	126 × 130 mm (5.0" × 5.1")
Piston displacement	9726 cc (594 cu in)
Compression ratio	17 : 1
Rated gross horse power	162 kW / 2200 rpm
Maximum gross torque at 1400rpm	860 N · m
Engine oil quantity	24 ℓ (6.3 U.S. gal)
Dry weight	1000 kg (2000 lb)
High idling speed	2400 ± 50 rpm
Low idling speed	750 ± 50 rpm
Rated fuel consumption (at rated)	225 g/kW · hr
Starting motor	24 V-8.1 kW
Alternator	24 V-55 Amp
Battery	2 × 12 V × 120 Ah

2) MAIN PUMP

Item	Specification
Type	Fixed displacement gear pump
Capacity	151.1 cc/rev
Maximum operating pressure	190 kgf/cm ² (2700 psi)
Rated oil quantity	332 ℓ /min (87.7 U.S.gpm)
Rated speed	2200 rpm

3) STEERING PUMP

Item	Specification
Type	Fixed displacement gear pump
Capacity	80 cc/rev
Maximum operating pressure	160 kgf/cm ² (2280 psi)
Rated oil quantity	151 ℓ /min (39.9 U.S.gpm)
Rated speed	2200 rpm

4) MAIN CONTROL VALVE

Item	Specification
Type	2 spool
Operating method	Mechanical control
Main relief valve set pressure	190 kgf/cm ² (2700 psi)
Overload relief valve set pressure (bucket in)	200 kgf/cm ² (2840 psi)

5) CYLINDER

Item	Specification
Boom cylinder	Bore dia × Rod dia × Stroke Ø 160 × Ø 80 × 820 mm
Bucket cylinder	Bore dia × Rod dia × Stroke Ø 180 × Ø 100 × 545 mm
Steering cylinder	Bore dia × Rod dia × Stroke Ø 90 × Ø 50 × 440 mm

6) DYNAMIC POWER TRANSMISSION DEVICES

Item		Specification	
Transmission	Model	ZL50	
	Type	Converter	Double-stage, Double-phase
		Transmission	Mechanical, hydraulic
	Gear shift	Forward second gear, reverse first gear	
	Control	Mechanical single lever type	
Axle	Drive devices	4-wheel drive	
	Front	Front fixed location	
	Rear	Oscillation $\pm 12^\circ$ of center pin-loaded	
Wheels	Tires	23.5-25, 16PR (L3)	
Brakes	Travel	Four-wheel, dry-disc type, pneumatic	
	Parking	Drum type brake on transmission, pneumatic	
Steering	Type	Hydraulic, articulated	
	Steering angle	40° to both right and left angle, respectively	

4. TIGHTENING TORQUE OF MAJOR COMPONENT

No.	Descriptions	Bolt size	Torque		
			kgf · m	lbf · ft	
1	Engine	Engine mounting bolt (2EA)	M24×3.0	100 ± 15	723 ± 108
2		Engine mounting bolt (bracket)	M12×1.75	10.7 ± 1.6	77.4 ± 11.6
3		Radiator mounting bolt	M16×2.0	29.7 ± 4.5	215 ± 32.5
4		Fuel tank mounting bolt	M16×2.0	29.7 ± 4.5	215 ± 32.5
5	Hydraulic system	Main pump housing mounting bolt	M12×1.75	12.8 ± 3.0	92.6 ± 21.7
6		Main control valve mounting bolt	M12×1.75	12.8 ± 3.0	92.6 ± 21.7
7		Steering unit mounting bolt	M10×1.5	6.9 ± 1.4	49.9 ± 10.1
8		Steering valve mounting bolt	M10×1.5	6.9 ± 1.4	49.9 ± 10.1
9		Brake valve mounting bolt	M8×1.25	2.5 ± 0.5	18.1 ± 3.6
10		Control lever mounting bolt	M10×1.5	6.9 ± 1.4	49.9 ± 10.1
11		Hydraulic oil tank mounting bolt	M16×2.0	29.7 ± 4.5	215 ± 32.5
12	Power train	Transmission mounting bolt	M24×3.0	100 ± 15	723 ± 108
13		Transmission mounting bolt (bracket)	M18×2.5	32.7 ± 4.9	237 ± 35.4
14		Torque converter housing mounting bolt	M12×1.75	10.7 ± 1.6	77.4 ± 11.6
15		Front axle mounting bolt, nut	M30×2.0	200 ± 15	1447 ± 108
16		Tire mounting nut	M20×1.5	79 ± 2.0	571 ± 14.5
17		Drive shaft joint mounting bolt, nut	1/2-20UNF	15.5 ± 0.5	112 ± 3.6
18	Others	Counterweight mounting bolt	M30×2.0	199 ± 29.9	1439 ± 216
19		Operator seat mounting bolt	M8×1.25	3.4 ± 0.8	24.5 ± 5.8
20		Cab mounting bolt (4EA)	M27×3.0	70 ± 10	506 ± 72.3

5. TORQUE CHART

Use following table for unspecified torque.

1) BOLT AND NUT

(1) Coarse thread

Bolt size	8T		10T	
	kg · m	lb · ft	kg · m	lb · ft
M 6 × 1.0	0.85 ~ 1.25	6.15 ~ 9.04	1.14 ~ 1.74	8.2 ~ 12.6
M 8 × 1.25	2.0 ~ 3.0	14.5 ~ 21.7	2.73 ~ 4.12	19.7 ~ 29.8
M10 × 1.5	4.0 ~ 6.0	28.9 ~ 43.4	5.5 ~ 8.3	39.8 ~ 60
M12 × 1.75	7.4 ~ 11.2	53.5 ~ 79.5	9.8 ~ 15.8	71 ~ 114
M14 × 2.0	12.2 ~ 16.6	88.2 ~ 120	16.7 ~ 22.5	121 ~ 167
M16 × 2.0	18.6 ~ 25.2	135 ~ 182	25.2 ~ 34.2	182 ~ 247
M18 × 2.5	25.8 ~ 35.0	187 ~ 253	35.1 ~ 47.5	254 ~ 343
M20 × 2.5	36.2 ~ 49.0	262 ~ 354	49.2 ~ 66.6	356 ~ 482
M22 × 2.5	48.3 ~ 63.3	350 ~ 457	65.8 ~ 98.0	476 ~ 709
M24 × 3.0	62.5 ~ 84.5	452 ~ 611	85.0 ~ 115	615 ~ 832
M30 × 3.0	124 ~ 168	898 ~ 1214	169 ~ 229	1223 ~ 1655
M36 × 4.0	174 ~ 236	1261 ~ 1703	250 ~ 310	1808 ~ 2242

(2) Fine thread

Bolt size	8T		10T	
	kg · m	lb · ft	kg · m	lb · ft
M 8 × 1.0	2.17 ~ 3.37	15.7 ~ 24.3	3.04 ~ 4.44	22.0 ~ 32.0
M10 × 1.25	4.46 ~ 6.66	32.3 ~ 48.2	5.93 ~ 8.93	42.9 ~ 64.6
M12 × 1.25	7.78 ~ 11.58	76.3 ~ 83.7	10.6 ~ 16.0	76.6 ~ 115
M14 × 1.5	13.3 ~ 18.1	96.2 ~ 130	17.9 ~ 24.1	130 ~ 174
M16 × 1.5	19.9 ~ 26.9	144 ~ 194	26.6 ~ 36.0	193 ~ 260
M18 × 1.5	28.6 ~ 43.6	207 ~ 315	38.4 ~ 52.0	278 ~ 376
M20 × 1.5	40.0 ~ 54.0	289 ~ 390	53.4 ~ 72.2	386 ~ 522
M22 × 1.5	52.7 ~ 71.3	381 ~ 515	70.7 ~ 95.7	512 ~ 692
M24 × 2.0	67.9 ~ 91.9	491 ~ 664	90.9 ~ 123	658 ~ 890
M30 × 2.0	137 ~ 185	990 ~ 1338	182 ~ 248	1314 ~ 1795
M36 × 3.0	192 ~ 260	1389 ~ 1879	262 ~ 354	1893 ~ 2561

2) PIPE AND HOSE (FLARE type)

Thread size (PF)	Width across flat (mm)	kgf · m	lbf · ft
1/4"	19	4	28.9
3/8"	22	5	36.2
1/2"	27	9.5	68.7
3/4"	36	18	130
1"	41	21	152
1-1/4"	50	35	253

3) PIPE AND HOSE (ORFS type)

Thread size (UNF)	Width across flat (mm)	kgf · m	lbf · ft
9/16-18	19	4	28.9
11/16-16	22	5	36.2
13/16-16	27	9.5	68.7
1-3/16-12	36	18	130
1-7/16-12	41	21	152
1-11/16-12	50	35	253

4) FITTING

Thread size	Width across flat (mm)	kgf · m	lbf · ft
1/4"	19	4	28.9
3/8"	22	5	36.2
1/2"	27	9.5	68.7
3/4"	36	18	130
1"	41	21	152
1-1/4"	50	35	253

6. RECOMMENDED LUBRICANTS

Use only oils listed below or equivalent.

Do not mix different brand oil.

Service point	Kind of fluid	Capacity ℓ (U.S. gal)	Ambient temperature °C (°F)						
			-20 (-4)	-10 (14)	0 (32)	10 (50)	20 (68)	30 (86)	40 (104)
Engine oil pan	Engine oil	20 (5.3)	SAE 30						
			SAE 10W						
			SAE 10W-30						
			SAE 15W-40						
Transmission	Gear oil	50 (13.2)	ATF DEXRON III						
Axle	Gear oil	Front : 28 (7.4) Rear : 28 (7.4)	SAE 80W-90						
			SAE 85W-90						
Hydraulic tank	Hydraulic oil	Tank : 150 (39.6) System : 260 (68.7)	ISO VG 32						
			ISO VG 46						
			ISO VG 68						
Fuel tank	Diesel fuel	280 (74)	ASTM D975 NO.1						
			ASTM D975 NO.2						
Fitting (grease nipple)	Grease	As required	NLGI NO.1						
			NLGI NO.2						
Radiator	Mixture of antifreeze and water 50 : 50	44 (11.6)	Ethylene glycol base permanent type						

- SAE : Society of Automotive Engineers
- API : American Petroleum Institute
- ISO : International Organization for Standardization
- NLGI : National Lubricating Grease Institute
- ASTM : American Society of Testing and Material
- ATF : Auto Transmission Fluid