

GROUP 2 STRUCTURE AND FUNCTION

1. MAIN PUMP

1) STRUCTURE

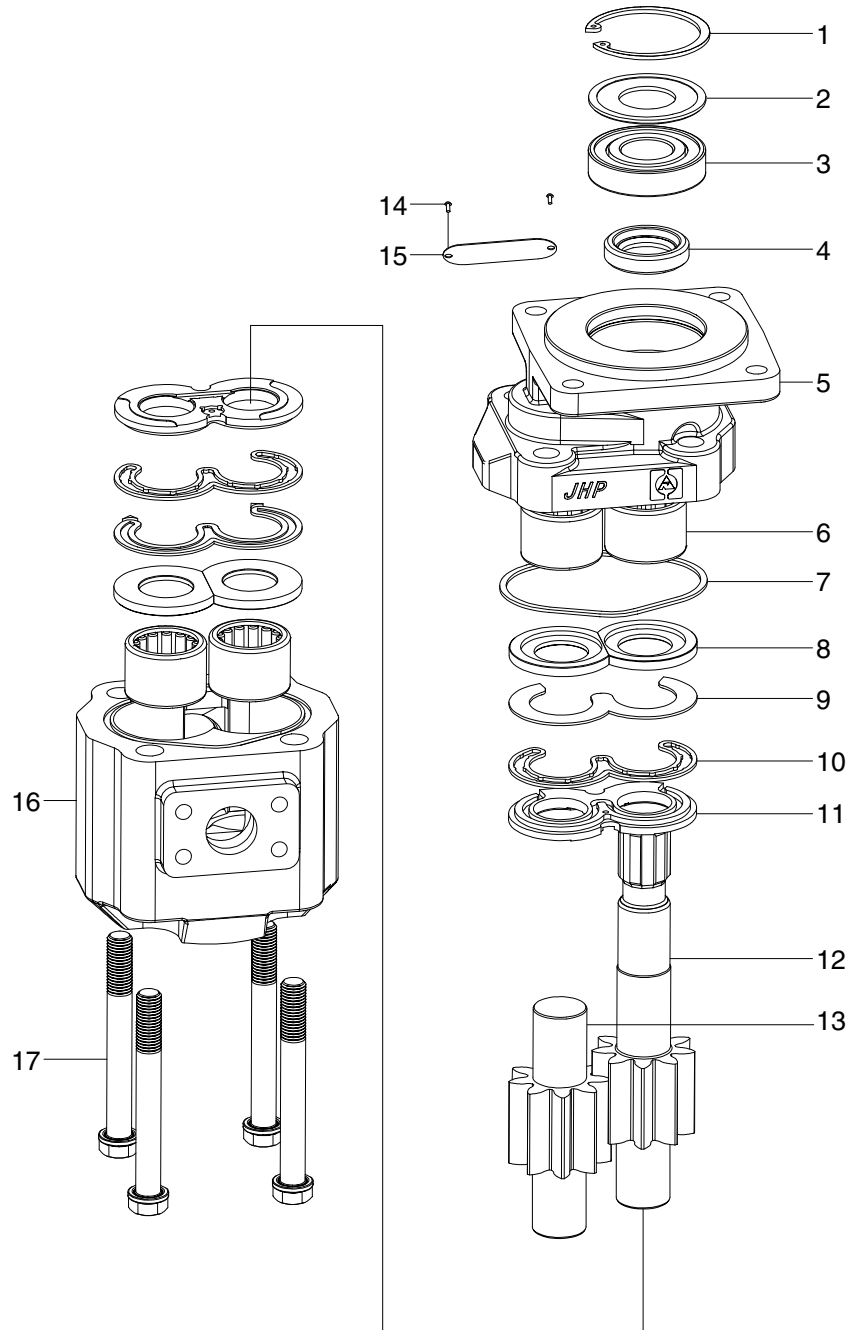

850KMP10

- | | | | | | |
|---|-------------|----|------------|----|-------------|
| 1 | Snap ring | 7 | Seal | 13 | Driven gear |
| 2 | Dust seal | 8 | Seal | 14 | Rivet |
| 3 | Bearing | 9 | Seal | 15 | Name plate |
| 4 | Shaft seal | 10 | Seal | 16 | Housing |
| 5 | Front cover | 11 | Wear plate | 17 | Bolt |
| 6 | Bearing | 12 | Drive gear | | |

2) MOUNTING REQUIREMENTS FOR GEAR PUMP

- (1) Before mounting the gear pump, check its normal rotating direction and for being suitable to whole system.
- (2) Entry of gear pump should keep clean and no pollution. Interfacing surface of entry and discharge should not be damaged and good sealing with O-ring seal should be guaranteed.
- (3) Check if the depth of mounting hole for gear pump is longer than the length of the shaft of pump so to prevent potential impact to the shaft and gear pump from burning out. Key shaft should be assembled normally.

3) NOTES IN USING

- (1) It's strictly prohibited for user to disassemble the product, or the manufacturer will not guarantee the performance of product.
- (2) Viscosity of oil is dependant to temperature. When oil temperature increases, its viscosity decreases. Therefore, oil temperature should be maintained under 80°C. To secure the gear pump working normally under different operating temperature, selected oil should feature little change by variation of temperature, and have good chemical durability and foam resistance. Use of ISO VG46 (ISO VG32, ISO VG68) anti-wear hydraulic oil is recommended.
- (3) No impurities from machine and corrosive substance should be in oil. There should be filtering devices with a precision of 25 µm in the system where the gear pump is working for.
- (4) For transmission of gear pump, the manners that may produce radial force to pump (such as direct geared and pulley transmission) are not permitted. Shaft bushing or elastic coupling can be used. Requirements for concentricity: not more than 0.05 mm for shaft bushing type, no more than 0.1 mm for coupling type. Axial force is not permitted.
- (5) The entry and discharge of gear pump should be assembled securely and sealing be reliable. Or air may be included and oil leaks caused to lower the performance of gear pump.
- (6) Max. pressure and max. rate of gear pump means momentary peak values permitted during operation. Long time of continued use of gear pump may shorten its life span.
- (7) Check if the depth of mounting hole for gear pump is longer than the length of the shaft of pump so to prevent potential impact to the shaft and gear pump from burning out.
- (8) Before mounting the gear pump, check the rotating direction of pump meets requirement.

4) TROUBLESHOOTING

Problem	Cause	Remedy
Noise in pump	Air in system.	Fasten up all the connectors.
	Insufficient oil supply.	Refill oil to an adequate level.
	Cold oil.	Run slowly.
	Contaminated suction filter.	Clean or replace the filter.
	Too thin suction pipe.	Use a larger pipe.
	Suction pipe is clogged.	Remove the obstruction.
	Clogged air filter in oil tank.	Clean or replace the air filter.
	Poor concentricity of pump and input shaft.	Inspect.
	Severe resonance with tank, peripheral parts of piping.	Check piping, elements and bolts for being securely fastened.
Pump lags in response or no response	Insufficient oil supply.	Refill oil to an adequate level.
	Improper pressure setting of relief valve.	Regulate the pressure of relief valve.
	Worn or damaged pump.	Repair or replace.
	Worn, leaking or stuck valve.	Repair or replace.
High oil temperature	Too low pressure setting at overflow valve.	Regulate pressure of overflow valve.
	Too low viscosity of hydraulic oil.	Use recommended hydraulic oil.
	Too low oil level.	Refill oil to an adequate level.
	Small tank.	Add an oil cooler or replace with larger tank.
	Worn or damaged pump.	Repair or replace.
Foam forms in oil	Air has entered into oil tank through suction pipe.	Fasten up all the connectors.
	Incorrect selection of oil.	Use recommended oil.
	Too low oil level.	Refill oil to an adequate level.
	Worn or damaged lip seal for main shaft.	Replace the lip seal for main shaft.

Problem	Cause	Remedy
Insufficient flow of pump or pressure	Damaged side plate.	Replace side plate.
	Air has entered into the system.	Fasten up all the connectors.
	Too high viscosity of oil.	Use recommended oil.
Leaks occur even after replacing lip seal for main shaft	Contaminated oil.	Change all the oil.
	Damaged lip seal for main shaft has damaged the sealing area of drive gear.	Replace drive gear shaft.
	Worn or damaged seal ring.	Replace seal ring.

5) NOTICE IN PLACING ORDER

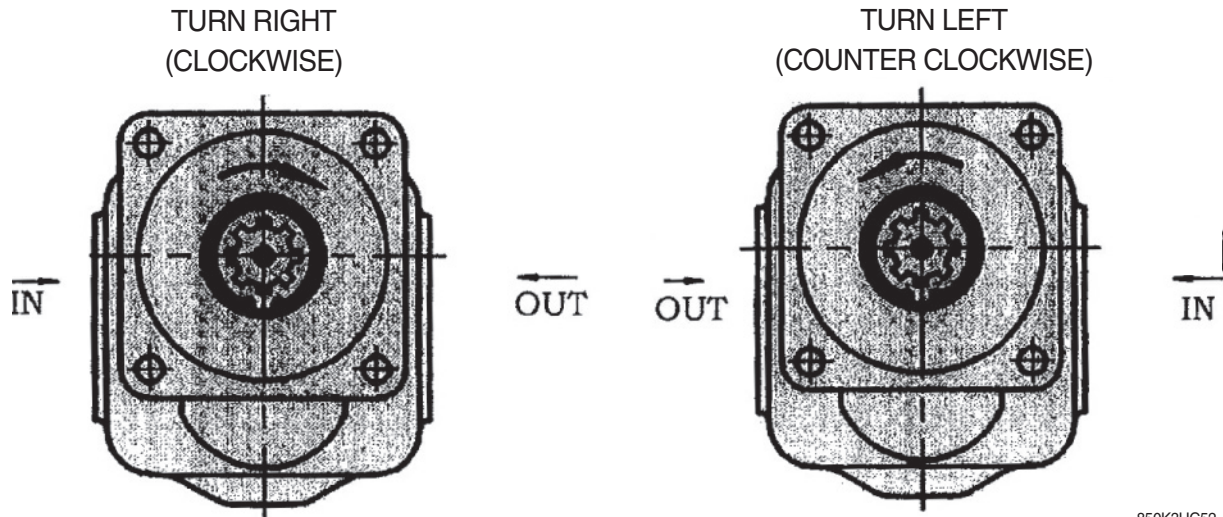

850K3HC52

2. MAIN CONTROL VALVE

1) STRUCTURE

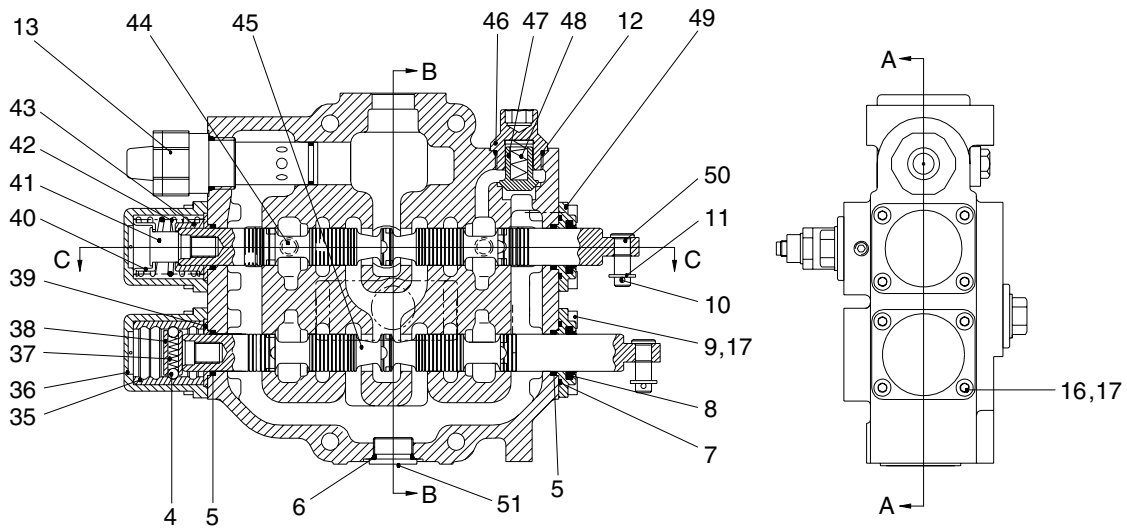

SECTION A-A

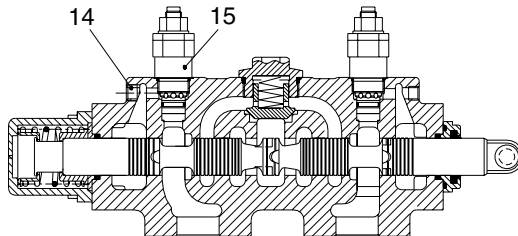

SECTION C-C

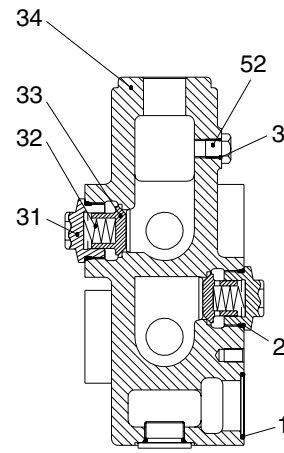

SECTION B-B

1 O-ring	15 Relief valve	41 Stopper
2 O-ring	16 Bolt	42 Spring
3 O-ring	17 Washer	43 Spring retainer
4 Ball	31 Plug	44 Spool
5 O-ring	32 Spring	45 Spool
6 O-ring	33 Poppet	46 Plug
7 O-ring	34 Body	47 Poppet
8 Dust seal	35 Spool	48 Spring
9 Bolt	36 End cover	49 Plate
10 Snap ring	37 Spring	50 Pin
11 Ring	38 Spacer	51 Plug
13 Relief valve	39 Spacer	52 Plug
14 Plug	40 Spring retainer	

850KSE17

SAFETY RELIEF VALVE

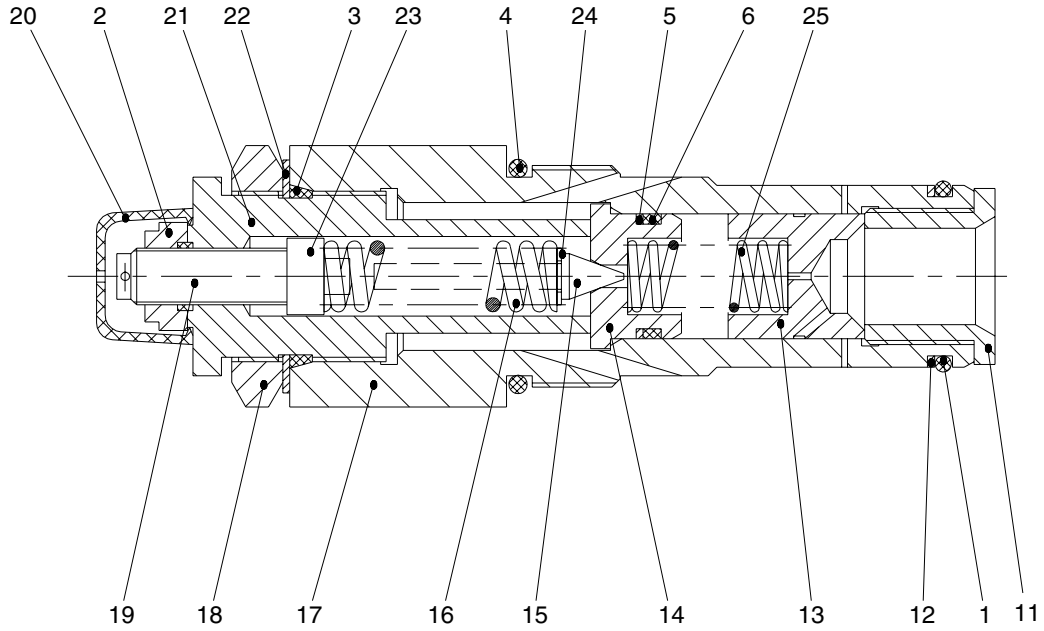

850KSE18

- | | | |
|------------|-----------------|-----------------|
| 1 Seal | 12 Back up seal | 19 Adjust screw |
| 2 Lock nut | 13 Spring seat | 20 Cap |
| 3 Seal | 14 Spring seat | 21 Body |
| 4 O-ring | 15 Poppet | 22 Washer |
| 5 Seal | 16 Spring | 23 Spring seat |
| 6 Seal | 17 Housing | 24 Spring seat |
| 11 Seat | 18 Nut | 25 Spring |

2) OVERVIEW

Multi-way directional valve is of integrated slide valve structure which includes 2 spools valve (bucket and boom spool) and triple multi-way valve (service spool, bucket spool, boom spool). Oil ways include parallel and series connection. Multi-way valve has also various service valves (overflow valve, overload valve, makeup valve) attached. As a hydraulic device for main equipment of large and medium loader, the valve features compact structure, reliable functions, high performance, good sealing, and convenient repair.

3) MODEL IDENTIFICATION

DFS - XX -XX

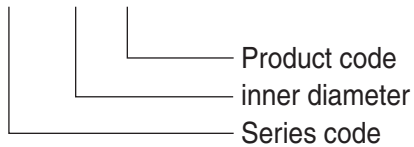

4) TECHNICAL DATA

Item	Unit	Specification
Nominated flow	ℓ /min	250
Nominated pressure	MPa	16
Pressure regulating range	MPa	8 ~ 20
Pressure loss	Center	<0.3
	Direction change	<0.6
Pressure regulating range of overload valve	MPa	8 ~ 25

5) STRUCTURE AND WORKING PRINCIPLE

(1) Structure

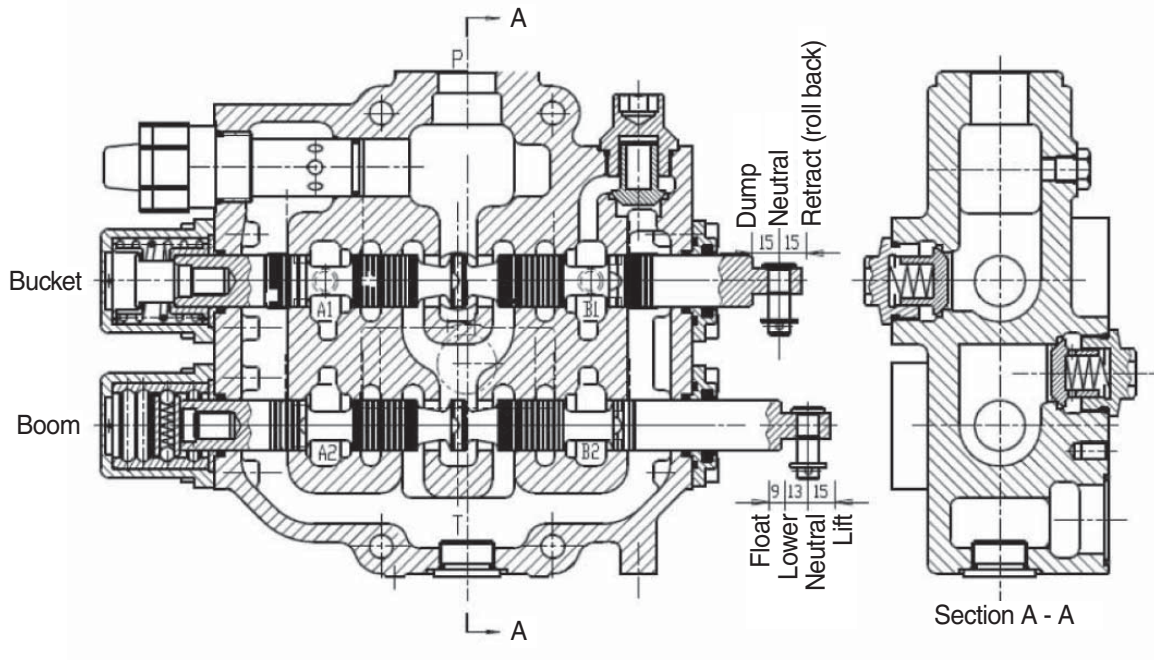

850K3HC51

(2) Working Principle

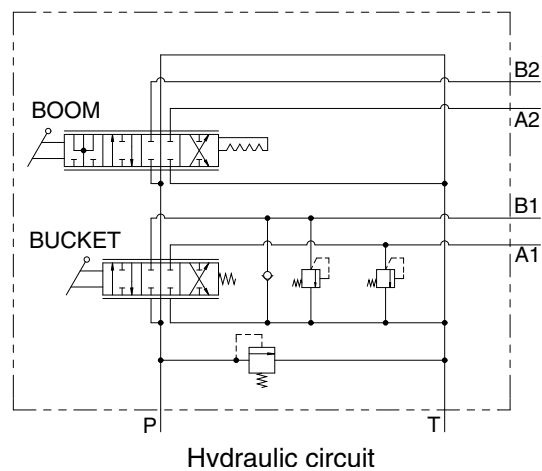

Hydraulic circuit

850K3HC50

The Multi-way directional valve has boom control lever and bucket control lever. The bucket lever has three positions, i.e. neutral, roll back and dump. Boom lever has four positions, i.e., hold, raise, lower and float. Port P is flow inlet, T is flow return port and port A1 and B1 are connected to large and small chamber bucket cylinder respectively, and port A2 and B2 are to large and small chamber of boom cylinder.

① **Neutral position**

When bucket control lever and boom control lever are in neutral positions, the flow from pump returns from inlet port P to tank through middle oil way.

② **Bucket roll back and dump**

When bucket control lever is shifted to back, the flow from pump opens one-way valve, and is directed to A1 cavity, then to large chamber of bucket cylinder to make the bucket roll back, while the flow in small cavity returns through cavity B1. Similarly, when bucket lever is shifted to forward, the flow from pump opens one-way valve, and is directed to cavity B1, then to small chamber of bucket cylinder to make the bucket dump, while flow in large chamber return through cavity A1.

③ **Float of Boom**

When the boom control lever is shifted to back, the flow from pump opens one-way valve, and is directed to cavity A2, then to large chamber of boom cylinder to make the boom to raise, while the flow in small chamber returns through cavity B2. Likewise, when the boom control lever is shifted to forward, the flow from pump opens one-way valve, and is directed to cavity B2, then to small chamber of boom cylinder to make the boom to lower, while the flow in large chamber returns through cavity A2. When the control lever of boom is in lower, move it further to forward to get in float position. At the time, all of inlet port P and large and small chambers of cylinder are connected to return way, and become under low pressure, and the cylinder is floating by the weight of working equipment and bearing force of ground.

④ **Function of main relief valve, overload valve and makeup valve**

Main relief valve controls pressure in system. When pressure in system exceeds rated pressure, the main relief valve opens and the flow returns to tank to protect the hydraulic system against over pressure. When the bucket receives external impact or is interfered with by other mechanism, overload valve opens for safety. Makeup valve functions to make up oil for cylinder to prevent a chamber to be evacuated.

6) MOUNTING AND USING

- (1) When transporting, mounting, and storing the product, be careful that the product does not receive impacts that may damage the machined surface or flange face.
- (2) Never disassemble the product in dust before assembling to machine to prevent dust from entering.
- (3) Check that rated pressure, sliding function, oil-way type and other features conform to system requirements.
- (4) Mounting plate should be level, mounting screws fastened in even torque, and the valves should be in good alignment.
- (5) Operating fluid should be clean, cleanliness meeting NAS 1638 10 grade and up.
- (6) Allowable oil temperature range: -20 ~ 80°C, normal oil temperature $50 \pm 5^\circ\text{C}$.
- (7) Connect each port correctly and piping shall not be too thin, too long.
- (8) Our company offers three-guarantees to the product for one year from delivery for any malfunctions resulted from problem in workmanship in case the user would have observed the provisions given with regard to storage, use, installation and transportation.

7) TROUBLESHOOTING

No.	Problem	Cause	Remedy
1	Insufficient operating pressure	1. Pressure of main relief valve is on low side.	1. Regulate pressure of main relief valve.
		2. Spool of main relief valve is stuck.	2. Remove and clean, or replace valve spool.
		3. Damaged pressure regulating spring.	3. Replace with new product.
		4. Too much pressure loss in system line.	4. Replace piping, or regulate pressure of main relief valve within the allowable range of pressure.
2	Insufficient operating flow	1. Oil supply to system is insufficient.	Check oil source and repair oil pump.
		2. Too much leaks inside valve.	
		a. Too high oil temperature, low viscosity	a. Take measures to reduce oil temperature.
		b. Improper hydraulic oil.	b. Change hydraulic oil.
		c. Too much clearance between slide valve and valve body.	c. Replace slide valve to keep a reasonable clearing.
		3. Main relief valve failure.	3. Repair or replace the main relief valve.
3	Malfunction in return.	1. Damaged or deformed return spring.	1. Replace with new product.
		2. Dirt between valve lever and valve body.	2. Clean part.
4	External seeps and leaks	1. Damaged seal ring.	1. Replace with new product.
		2. Loose fastening pieces.	2. Fasten related fastening piece.
		3. Too high oil temperature, low viscosity	3. Takes measures to reduce oil temperature.
		4. Poor sealing on flange surface.	4. Check fastening and sealing of related parts.

8) NOTES IN DISASSEMBLY

- (1) Keep clean field for assembly. Dust and dirt shall be strictly prevented.
- (2) Never clean rubber sealing pieces with gasoline.
- (3) To prevent from damage to part, never knock a part with an iron object when disassembling.
- (4) Be sure to clean all the parts with kerosene or cleaner before assembling.
- (5) After assembling, be sure to perform test and only passed product can be used.

3. BOOM CYLINDER

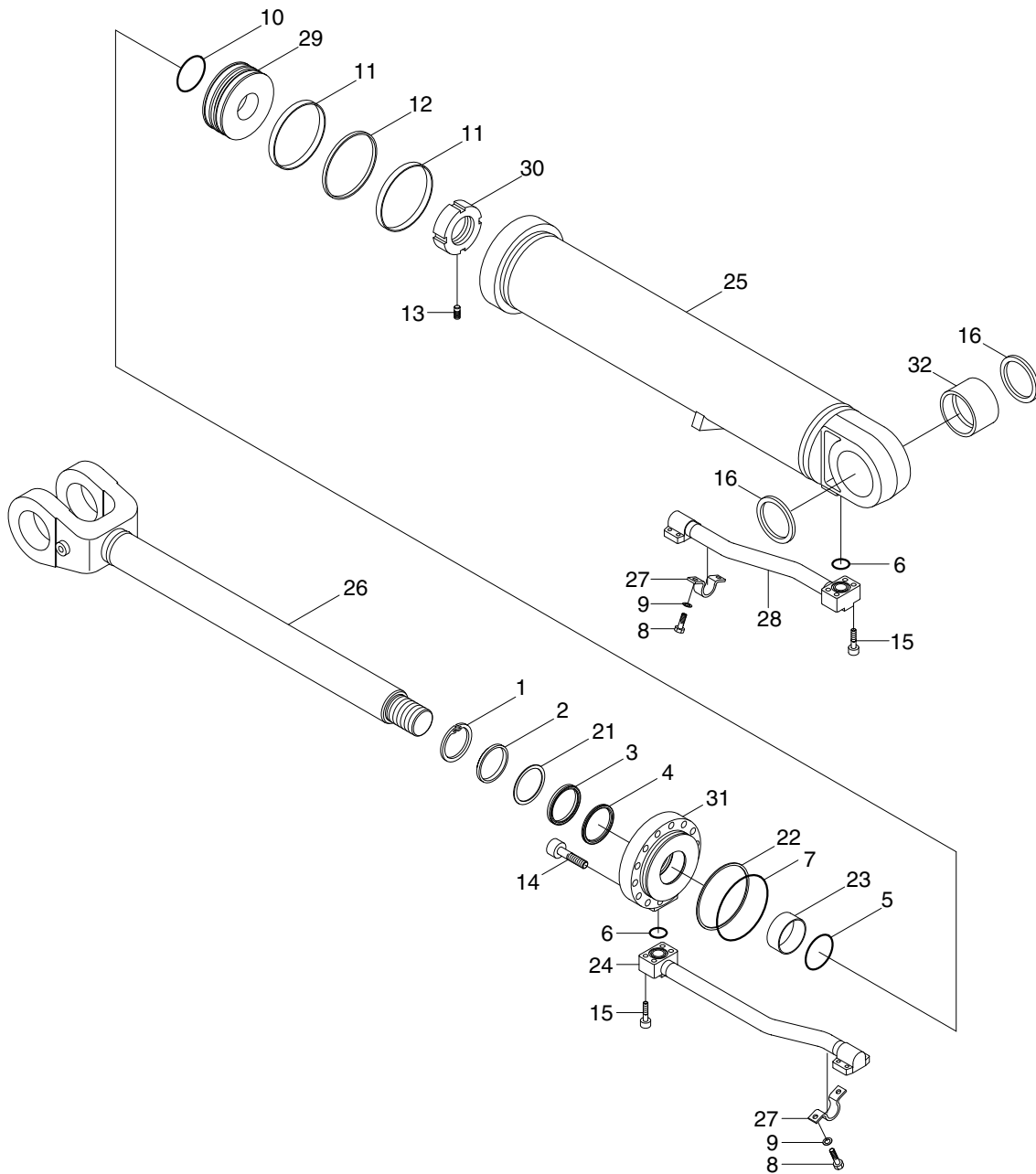

850KSE19E

- | | | | | | |
|----|---------------|----|---------------|----|---------------|
| 1 | Snap ring | 11 | Wear ring | 25 | Tube assembly |
| 2 | Dust wiper | 12 | Piston seal | 26 | Rod assembly |
| 3 | Rod seal | 13 | Set screw | 27 | Pipe clamp |
| 4 | Buffer ring | 14 | Socket bolt | 28 | Pipe assembly |
| 5 | Snap ring | 15 | Socket bolt | 29 | Piston |
| 6 | O-ring | 16 | Dust seal | 30 | Lock nut |
| 7 | Back up ring | 21 | Back up ring | 31 | Gland |
| 8 | Hexagon bolt | 22 | O-ring | 32 | Pin bushing |
| 9 | Spring washer | 23 | Du bushing | | |
| 10 | O-ring | 24 | Pipe assembly | | |

4. BUCKET CYLINDER

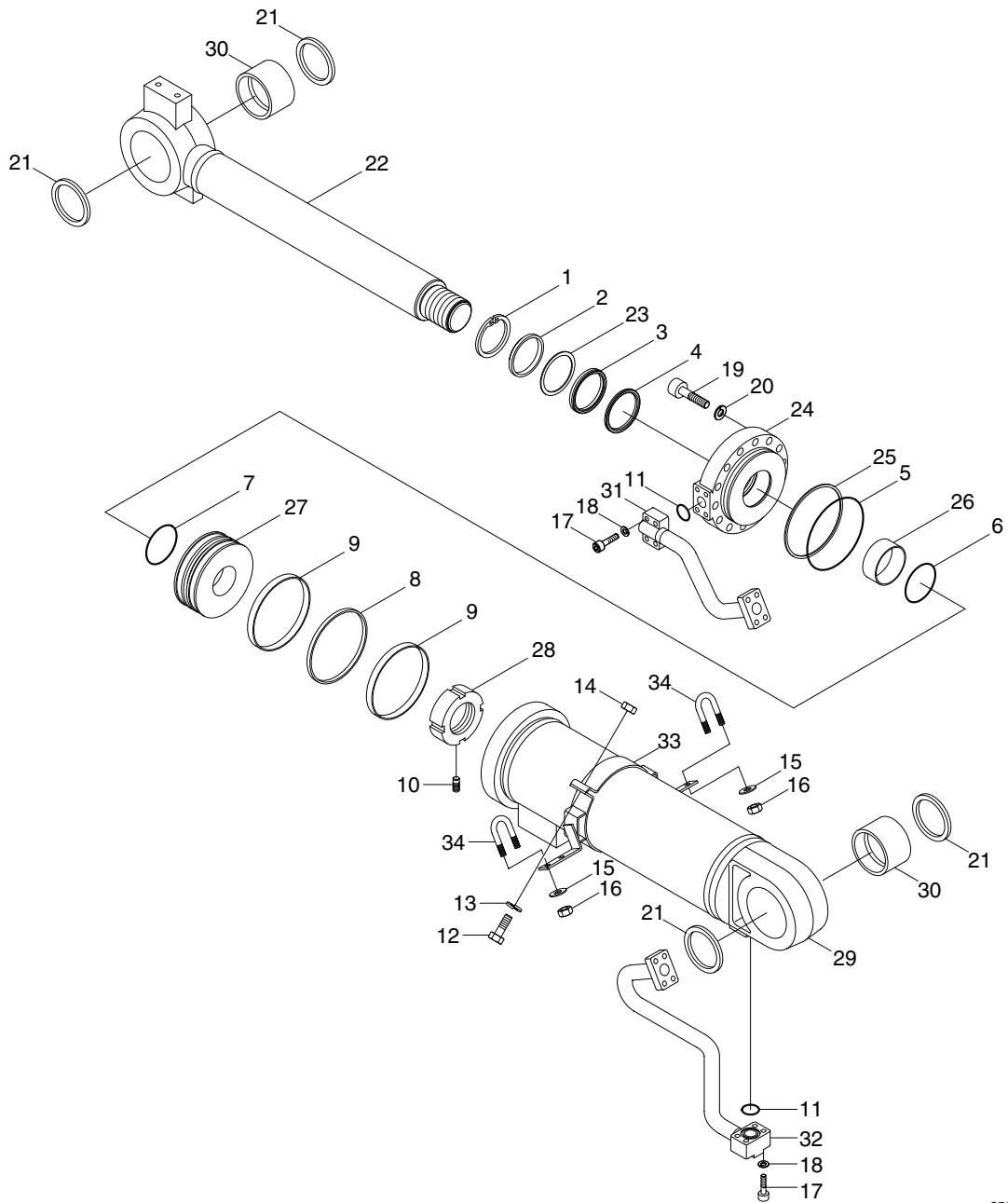

850KSE20E

- | | | | | | |
|----|--------------|----|---------------|----|---------------|
| 1 | Snap ring | 13 | Spring washer | 25 | O-ring |
| 2 | Dust wiper | 14 | Hexagon bolt | 26 | Du bushing |
| 3 | Rod seal | 15 | Spring washer | 27 | Piston |
| 4 | Buffer ring | 16 | Hexagon nut | 28 | Lock nut |
| 5 | Back up ring | 17 | Socket bolt | 29 | Tube assembly |
| 6 | Snap ring | 18 | Spring washer | 30 | Pin bushing |
| 7 | O-ring | 19 | Socket bolt | 31 | Pipe assembly |
| 8 | Piston seal | 20 | Spring washer | 32 | Pipe assembly |
| 9 | Wear ring | 21 | Dust seal | 33 | Band assembly |
| 10 | Set screw | 22 | Rod assembly | 34 | U-bolt |
| 11 | O-ring | 23 | Back up ring | | |
| 12 | Hexagon bolt | 24 | Gland | | |