

## GROUP 3 TORQUE CONVERTER

### 1. FEATURES AND USE

Hydraulic torque converter is a single stage, single phase radial turbine hydraulic converter. This hydraulic torque converter features advanced structure, reliable operating, easily matching with engine, and convenient maintenance. It can be combined with an engine with rated rpm 2000~2400 and rated power approximately 80kW. In addition to the structural features of general hydraulic torque converter, this product features two output shafts and thus it can drive a hydraulic pump and another unit to meet the requirements of engine.

### 1) CONSTRUCTION AND OPERATING PRINCIPLE

Hydraulic torque converter is a single stage, single phase and three components hydraulic converter. This series of torque converter consists of energy converting components (pump pulley, turbine and guide pulley), power input and output components (elastic plate, cover wheel, turbine shaft and output flange), supporting component (casing), hydraulic components and other accessories.

#### • Operating principle

The pump pulley (1) connects to engine flywheel by power input components. Driven by mechanical energy from engine, the unit transforms the energy into hydraulic power  $M_B$  by centrifugal force. The fluid does not only turn around the supporting shaft in high velocity, but also make a circulating current along circulating way consisting of the ways of pump pulley (1), turbine (3) and guide pulley (2), which drives the turbine (3) to be transformed into mechanical energy  $M_T$  and outputted by power output members (7). The flow out from turbine (3) drives the guide pulley (2), which has functions to change direction of operating flow to direct it again to pump pulley (1). Since the guide pulley is fixed, the flow receives a counter torque  $M_D$  from the guide pulley as it effects onto the guide pulley, which drives the turbine (3) to change the value of torque of turbine, therefore the output torque will be  $M_T = M_B + M_D$ .

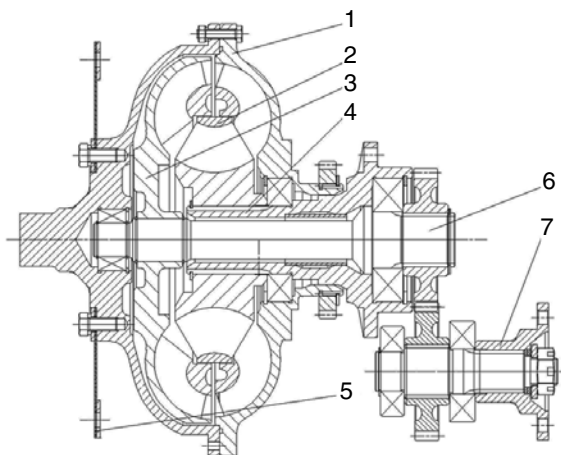

7352PT10

1	Pump pulley	4	Guide pulley seat	7	Output flange
2	Guide pulley	5	Elastic plate		
3	Turbine	6	Turbine shaft		

The function of oil inlet valve is to compensate pressure for the system, and automatically control the flow passing through the torque converter in line with working status and varying internal fluid pressure of torque converter, to control heat dissipating capacity of torque converter and, at the same time, to protect the torque converter against overpressure as the outlet of it is clogged. The function of return valve is to ensure entire the hydraulic system being in required operating state.

With such special construction and functions, hydraulic torque converter has following benefits as a transmitting component in comparison with mechanism:

- (1) With automatic torque control feature of a hydraulic torque converter, the machine can well adapt to sudden changes in load from outside, preventing from engine stall due to sudden increase of external load, to meet operating needs of operating equipment.
- (2) Since the unit uses liquid as operating medium, it can decrease and isolate vibration, saving the life of engineering machine. According to statistic data, the unit may increase the life of engine by 47%, and that of transmission box by 400%.
- (3) Trafficability and adaptability of vehicle can be enhanced.
- (4) Operating system of vehicle can be simplified.

## 2. TECHNICAL DATA

Item	Specification
Diameter of circular circle	315 mm
Nominal torque at zero-speed loading	$5.8 \pm 0.29$ kgf·m ( $42.0 \pm 2.1$ lbf·ft)
Nominal torque at high efficiency loading	$6.1 \pm 0.3$ kgf·m ( $44.1 \pm 2.2$ lbf·ft)
Torque ration at zero-speed loading	$3.0 \pm 0.15$
Max. efficiency	83%
Rated input	2200 rpm
Weight	179 kg
Dimensions	$470 \times 530 \times 530$ mm

### 3. USAGE AND MAINTENANCE

- 1) Before starting hydraulic torque converter, check each rotating part for smooth rotation and that if there is seizure and collision. Mount the hydraulic torque converter on the machine and add a suitable amount of hydraulic oil to the tank.
- 2) Start the engine and make the hydraulic torque converter to run for 1~2 minutes at low speed. Add oil to the tank again. Oil level should reach indicator line in running of hydraulic torque converter. Keep in mind to bleed air for the oil supply system when adding oil.
- 3) After starting hydraulic torque converter, run it in low speed and moderate speed in sequence, then under load. Frequently watch its running and check if there is abnormal noise. Immediately stop and check if abnormal. During operation, frequently check for variation of oil pressure and temperature and ensure that are within normal range. When the hydraulic torque converter is in use, be sure to check it at least once a week and, if oil level is below the line, add adequate amount of oil promptly.
- 4) It's required to renew oil for hydraulic torque converter after 100 hours of operation. After that, renew oil in the interval of 500 hours.
- 5) For mechanic transmission, the driver should make timely gear shift to prevent the engine from dying by sound heard during operation. No engine dying will occur if transmission of hydraulic torque converter is matched rationally. However, the driver still needs to change gear timely by oil temperature readings to prevent from overheated oil in low efficiency region of torque converter that may cause damage to sealing pack.

#### 4. OIL SUPPLY SYSTEM

In hydraulic torque converter, to prevent from adverse effect from cavitation corrosion and continued increase of temperature of operating fluid due to hydraulic loss which will result in too high fluid temperature and fluid leakage loss during compensating the torque converter, and to always ensure sufficient operating fluid inside hydraulic torque converter, it's required to use a make-up pump and continuously lead the fluid out of the torque converter for cooling. Then, the make-up pump needs to deliver the operating fluid again to the circulating circle at a certain pressure to prevent from decrease of pressure in the circulating circle due to fluid leakage loss, and deteriorated torque transmission performance of the torque converter due to air penetration through the sealings.

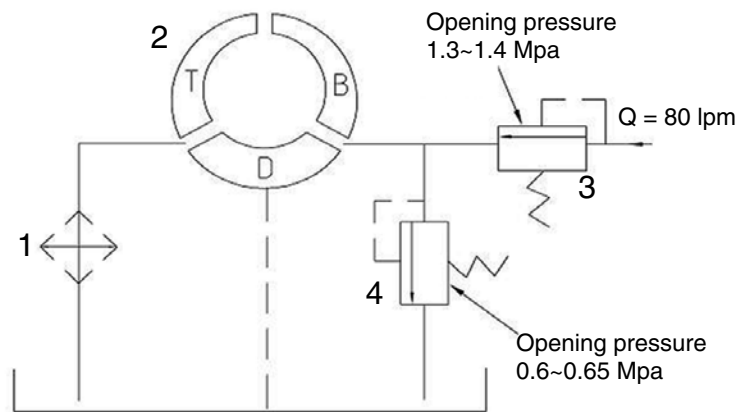

Schematic diagram for fluid supply system

7352PT11

- |                              |                       |
|------------------------------|-----------------------|
| 1 Cooler                     | 3 Main pressure valve |
| 2 Hydraulic torque converter | 4 Overflow valve      |

## 5. TROUBLESHOOTING

The hydraulic torque converter may encounter various malfunctions during operation, which may cause serious accident if not remedied timely. Therefore, you need to be careful to any abnormal situation occurring during use, and make through analysis to the malfunctions, then take appropriate actions to remedy with reference to below table.

Problem	Cause	Remedy
<b>Insufficient power output</b>	Engine rpm drops.	Increase engine rpm.
	Gas exists in hydraulic oil.	Check transmission oil level. Check for tightness of tubing system. Check for deteriorated hydraulic oil
	Too high hydraulic oil temperature.	Lower oil temperature
	Too low pressure of inlet/outlet valve of hydraulic torque converter.	Check for sensitivity of motion of each valve and hydraulic oil leaks.
<b>Too high oil temperature</b>	Too long time of operation in low efficiency region	Decrease external load or increase engine rpm.
	Too low oil level in oil tank or gas exists in hydraulic oil.	Add hydraulic oil, check for tightness of the connections of piping, and check for deteriorated oil.
	Oil does not meet requirements.	Use oil as recommended in operator's manual.
	Too low oil pressure in oil supply system.	Repair hydraulic valve, increase oil pressure.
	Low water level in cooling system.	Repair water tank.
	Insufficient oil supply.	Check oil supply system.
<b>Too low oil pressure in oil supply system</b>	Back pressure valve failure.	Replace back pressure valve.
	Clogged oil feed tube.	Check oil tubing.
	Insufficient oil supply of transmission oil pump.	Check and repair oil pump, or replace.
	Damaged or severely worn oil seal inside hydraulic torque converter.	Replace oil seal.
	Too low oil level in oil tank.	Add hydraulic oil.
	Clogged suction filter.	Clean or replace the filter.
	Failed pressure gauge.	Replace the pressure gauge.
<b>Oil leakage</b>	Damaged reinforced oil seal.	Replace the oil seal.
	Damaged O-ring.	Replace the O-ring.
<b>Aluminum dust exits in fluid</b>	Damaged bearing	Replace bearing.

# 6. OUTSIDE VIEW

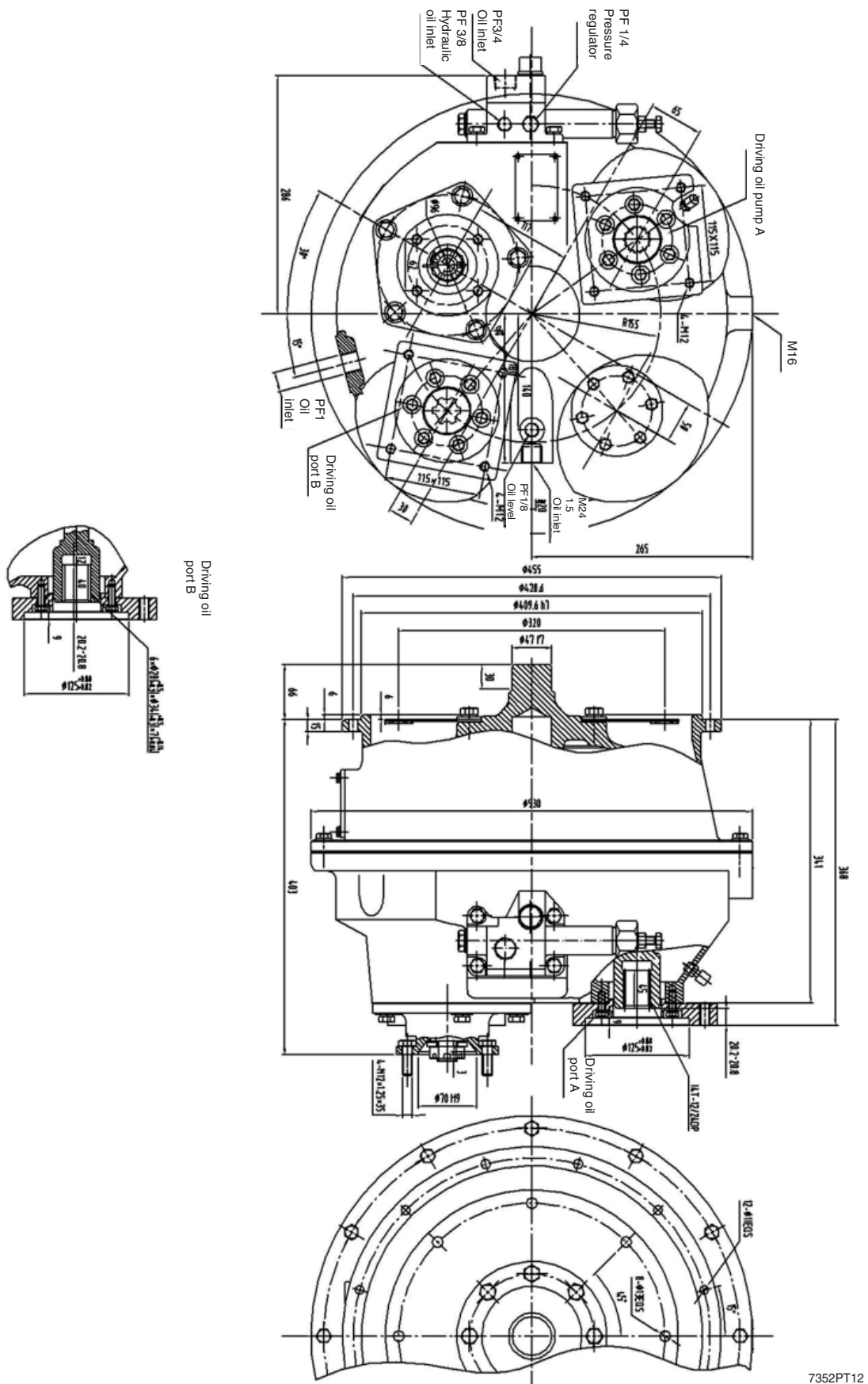

7352PT12