

GROUP 2 SPECIFICATION

1. MAJOR COMPONENT

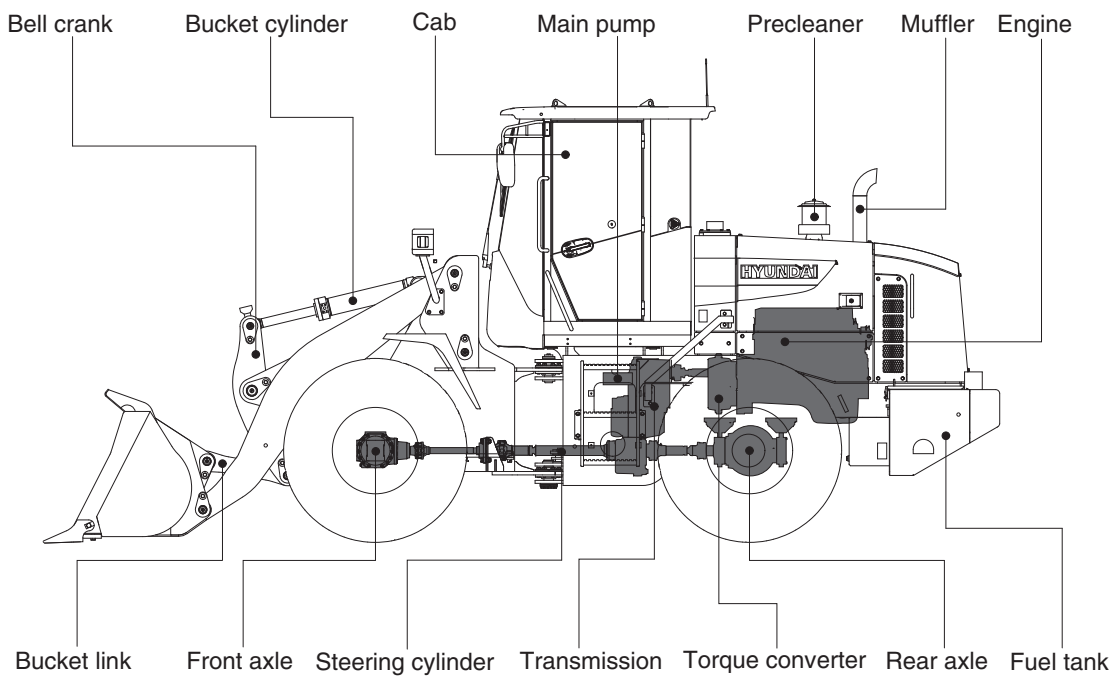
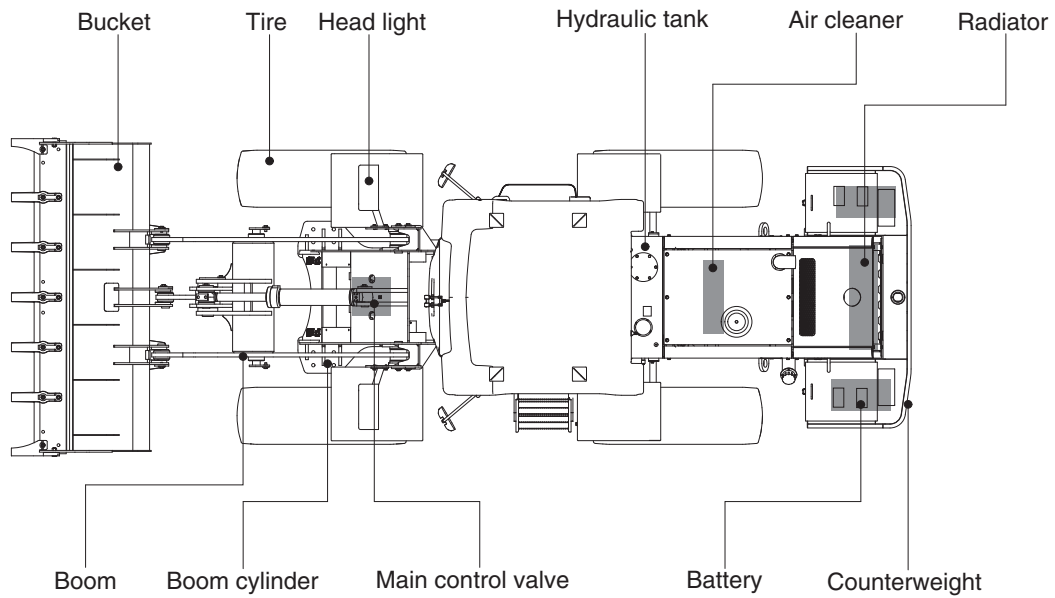

733S2SE01

2. SPECIFICATIONS

WITH TOOTH TYPE BUCKET

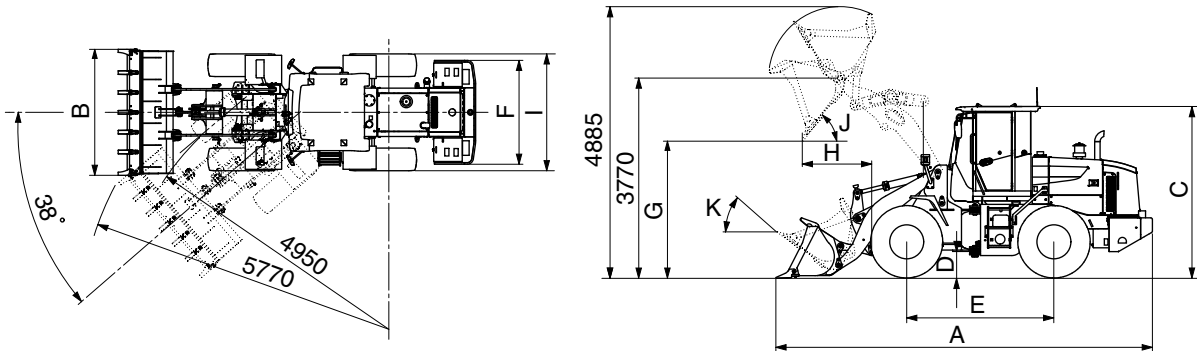

733S2SE04

Description		Unit	Specification
Operating weight		kg (lb)	10200 (22490)
Bucket capacity	Struck	m ³ (yd ³)	1.4 (1.8)
	Heaped		1.7 (2.2)
Overall length	A	mm (ft-in)	6965 (22' 10")
Overall width	B		2475 (8' 1")
Overall height	C		3215 (10' 7")
Ground clearance	D		370 (1' 3")
Wheelbase	E		2750 (9' 0")
Tread	F		1850 (6' 1")
Dump clearance at 45°	G		2790 (9' 2")
Dump reach (full lift)	H		1150 (3' 9")
Width over tires	I		2295 (7' 6")
Dump angle	J		degree (°)
Roll back angle (carry position)	K	43	
Cycle time	Lift (with load)	sec	5.4
	Dump (with load)		1.3
	Lower (empty)		3.0
Maximum travel speed		km/hr (mph)	40.0 (24.9)
Braking distance		m (ft-in)	13.7 (43' 0")
Minimum turning radius (center of outside tire)			4.95 (16' 3")
Gradeability		degree (°)	30
Travel speed	Forward	First gear	7.5 (4.7)
		Second gear	13.4 (8.3)
		Third gear	24.2 (15.0)
		Fourth gear	40.0 (24.9)
	Reverse	First gear	9.3 (5.8)
		Second gear	29.4 (18.3)

3. SPECIFICATION FOR MAJOR COMPONENTS

1) ENGINE

Item	Specification
Model	YC6J125Z-T20
Type	4-cycle turbocharged diesel engine.
Control type	Mechanical control
Cooling method	Water cooling
Number of cylinders and arrangement	6 cylinders, in-line
Firing order	1-5-3-6-2-4
Combustion chamber type	Direct injection type
Cylinder bore stroke	105 × 125 mm (4.1" × 4.9")
Piston displacement	6494 cc (396 cu in)
Compression ratio	17.5 : 1
Rated gross horse power	92 kW / 2200 rpm
Maximum gross torque at 1400~1600 rpm	500 N · m
Engine oil quantity	16 l (4.2 U.S. gal)
Dry weight	650 kg (1430 lb)
High idling speed	2400 ± 50 rpm
Low idling speed	725 ± 50 rpm
Rated fuel consumption (at rated)	215 g/kW · hr
Starting motor	24 V-6 kW
Alternator	28 V-55 Amp
Battery	2 × 12 V × 120 Ah

2) MAIN PUMP (+steering pump)

Item	Specification
Type	Fixed displacement gear pump
Capacity	100.8 cc/rev
Maximum operating pressure	200 kgf/cm ² (2840 psi)
Rated oil quantity	221 ℓ /min (58.4 U.S.gpm)
Rated speed	2200 rpm

3) MAIN CONTROL VALVE

Item	Specification
Type	2 spool
Operating method	Mechanical control
Main relief valve set pressure	173 kgf/cm ² (2460 psi)
Overload relief valve set pressure	193 kgf/cm ² (2750 psi)

4) CYLINDER

Item	Specification
Boom cylinder	Bore dia × Rod dia × Stroke Ø 110 × Ø 65 × 800 mm
Bucket cylinder	Bore dia × Rod dia × Stroke Ø 160 × Ø 80 × 380 mm
Steering cylinder	Bore dia × Rod dia × Stroke Ø 70 × Ø 45 × 293 mm

5) DYNAMIC POWER TRANSMISSION DEVICES

Item	Specification		
Transmission	Model	YJ315LH/BD08XD	
	Type	Converter	Single-stage, Single-phase
		Transmission	Mechanical, hydraulic
	Gear shift	Forward fourth gear, reverse second gear	
	Control	Mechanical single lever type	
Axle	Drive devices	4-wheel drive	
	Front	Front fixed location	
	Rear	Oscillation ± 11° of center pin-loaded	
Wheels	Tires	17.5-25, 14PR (L3)	
Brakes	Travel	Four-wheel, dry-disc type, pneumatic	
	Parking	Mechanical type brake on transmission	
Steering	Type	Hydraulic, articulated	
	Steering angle	38° to both right and left angle, respectively	

4. TIGHTENING TORQUE OF MAJOR COMPONENT

No.	Descriptions	Bolt size	Torque		
			kgf · m	lbf · ft	
1	Engine	Engine mounting bolt (4EA)	M18×2.5	30.4 ± 4.6	220 ± 33.3
2		Engine mounting bolt (bracket)	M12×1.5	9.03 ± 1.8	65.3 ± 13.0
3		Radiator mounting bolt	M12×1.75	9.03 ± 1.8	65.3 ± 13.0
4		Fuel tank mounting bolt	M16×2.0	21.9 ± 3.3	158 ± 23.9
5	Hydraulic system	Main pump housing mounting bolt	M12×1.75	9.03 ± 1.8	65.3 ± 13.0
6		Main control valve mounting bolt	M12×1.75	9.03 ± 1.8	65.3 ± 13.0
7		Steering unit mounting bolt	M10×1.5	5.0 ± 1.0	36.2 ± 7.2
8		Steering valve mounting bolt	M10×1.5	5.0 ± 1.0	36.2 ± 7.2
9		Brake valve mounting bolt	M8×1.25	2.5 ± 0.5	18.1 ± 3.6
10		Control lever mounting bolt	M10×1.5	5.0 ± 1.0	36.2 ± 7.2
11		Hydraulic oil tank mounting bolt	M16×2.0	21.9 ± 3.3	158 ± 23.9
12	Power train	Transmission mounting bolt	M16×2.0	21.9 ± 3.3	158 ± 23.9
13		Transmission mounting bolt (bracket)	M12×1.75	9.03 ± 1.8	65.3 ± 13.0
14		Torque converter housing mounting bolt	M10×1.5	5.0 ± 1.0	36.2 ± 7.2
15		Front axle mounting bolt, nut	M24×2.0	79.9 ± 12.0	578 ± 86.8
16		Rear axle mounting bolt, nut	M24×2.0	79.9 ± 12.0	578 ± 86.8
17		Tire mounting nut	M20×1.5	60.7 ± 5.6	439 ± 40.5
18		Drive shaft joint mounting bolt, nut	M14×1.5	21.0 ± 3.1	152 ± 22.4
	M12×1.25		13.3 ± 2.7	96.2 ± 19.5	
19	Others	Counterweight mounting bolt	M24×3.0	100 ± 15	723 ± 108
20		Operator seat mounting bolt	M8×1.25	3.4 ± 0.8	24.5 ± 5.8
21		Cab mounting bolt (4EA)	M27×3.0	70 ± 10	506 ± 72.3

5. TIGHTENING TORQUE

Use following table for unspecified torque.

1) BOLT AND NUT

(1) Coarse thread

Bolt size	8T		10T	
	kg · m	lb · ft	kg · m	lb · ft
M 6 × 1.0	0.85 ~ 1.25	6.15 ~ 9.04	1.14 ~ 1.74	8.2 ~ 12.6
M 8 × 1.25	2.0 ~ 3.0	14.5 ~ 21.7	2.73 ~ 4.12	19.7 ~ 29.8
M10 × 1.5	4.0 ~ 6.0	28.9 ~ 43.4	5.5 ~ 8.3	39.8 ~ 60
M12 × 1.75	7.4 ~ 11.2	53.5 ~ 79.5	9.8 ~ 15.8	71 ~ 114
M14 × 2.0	12.2 ~ 16.6	88.2 ~ 120	16.7 ~ 22.5	121 ~ 167
M16 × 2.0	18.6 ~ 25.2	135 ~ 182	25.2 ~ 34.2	182 ~ 247
M18 × 2.5	25.8 ~ 35.0	187 ~ 253	35.1 ~ 47.5	254 ~ 343
M20 × 2.5	36.2 ~ 49.0	262 ~ 354	49.2 ~ 66.6	356 ~ 482
M22 × 2.5	48.3 ~ 63.3	350 ~ 457	65.8 ~ 98.0	476 ~ 709
M24 × 3.0	62.5 ~ 84.5	452 ~ 611	85.0 ~ 115	615 ~ 832
M30 × 3.0	124 ~ 168	898 ~ 1214	169 ~ 229	1223 ~ 1655
M36 × 4.0	174 ~ 236	1261 ~ 1703	250 ~ 310	1808 ~ 2242

(2) Fine thread

Bolt size	8T		10T	
	kg · m	lb · ft	kg · m	lb · ft
M 8 × 1.0	2.17 ~ 3.37	15.7 ~ 24.3	3.04 ~ 4.44	22.0 ~ 32.0
M10 × 1.25	4.46 ~ 6.66	32.3 ~ 48.2	5.93 ~ 8.93	42.9 ~ 64.6
M12 × 1.25	7.78 ~ 11.58	76.3 ~ 83.7	10.6 ~ 16.0	76.6 ~ 115
M14 × 1.5	13.3 ~ 18.1	96.2 ~ 130	17.9 ~ 24.1	130 ~ 174
M16 × 1.5	19.9 ~ 26.9	144 ~ 194	26.6 ~ 36.0	193 ~ 260
M18 × 1.5	28.6 ~ 43.6	207 ~ 315	38.4 ~ 52.0	278 ~ 376
M20 × 1.5	40.0 ~ 54.0	289 ~ 390	53.4 ~ 72.2	386 ~ 522
M22 × 1.5	52.7 ~ 71.3	381 ~ 515	70.7 ~ 95.7	512 ~ 692
M24 × 2.0	67.9 ~ 91.9	491 ~ 664	90.9 ~ 123	658 ~ 890
M30 × 2.0	137 ~ 185	990 ~ 1338	182 ~ 248	1314 ~ 1795
M36 × 3.0	192 ~ 260	1389 ~ 1879	262 ~ 354	1893 ~ 2561

2) PIPE AND HOSE (FLARE type)

Thread size (PF)	Width across flat (mm)	kgf · m	lbf · ft
1/4"	19	4	28.9
3/8"	22	5	36.2
1/2"	27	9.5	68.7
3/4"	36	18	130
1"	41	21	152
1-1/4"	50	35	253

3) PIPE AND HOSE (24 cone type with O-RING)

Thread size (UNF)	Width across flat (mm)	kgf · m	lbf · ft
1/4"	19	1.6	11.6
3/8"	22	3.7	26.8
1/2"	27	4.7	34.0
3/4"	36	11.8	85.3
1"	41	13.9	100.5
1-1/4"	50	23.1	167

4) FITTING

Thread size	Width across flat (mm)	kgf · m	lbf · ft
1/4"	19	4	28.9
3/8"	22	5	36.2
1/2"	27	9.5	68.7
3/4"	36	18	130
1"	41	21	152
1-1/4"	50	35	253

6. RECOMMENDED OILS

Use only oils listed below or equivalent.

Do not mix different brand oil.

Service point	Kind of fluid	Capacity ℓ (U.S. gal)	Ambient temperature °C (°F)							
			-50 (-58)	-30 (-22)	-20 (-4)	-10 (14)	0 (32)	10 (50)	20 (68)	30 (86)
Engine oil pan	Engine oil	16 (4.2)	*1 SAE 5W-40							
			SAE 30							
			SAE 10W							
			SAE 10W-30							
			SAE 15W-40							
Transmission	Gear oil	43 (11.4)	AFT DEXRON III							
Axle	Gear oil	Front : 18 (4.8)	SAE 80W-90							
		Rear : 18 (4.8)	SAE 85W-90							
Hydraulic tank	Hydraulic oil	Tank; 90 (23.8)	*1 ISO VG 15							
		System; 160 (42.3)	ISO VG 46							
			ISO VG 68							
Fuel tank	Diesel fuel	155 (40.9)	*1 ASTM D975 NO.1							
			ASTM D975 NO.2							
Fitting (grease nipple)	Grease	As required	*1 NLGI NO.1							
			NLGI NO.2							
Radiator (reservoir tank)	Mixture of antifreeze and soft water*2	34 (9.0)	Ethylene glycol base permanent type (50 : 50)							
			*1 Ethylene glycol base permanent type (60 : 40)							
Brake (air booster)	Brake oil	Front : 1.0 (0.3) Rear : 1.0 (0.3)	DOT-3 synthetic brake fluid							

SAE : Society of Automotive Engineers

API : American Petroleum Institute

ISO : International Organization for Standardization

NLGI : National Lubricating Grease Institute

ASTM : American Society of Testing and Material

UTTO : Universal Tractor Transmission Oil

*1 Cold region

Russia, CIS, Mongolia

*2 Soft water

City water or distilled water