

GROUP 3 MONITORING SYSTEM

1. CLUSTER

The gauges panel consists of gauges and monitors as shown below, to warn the operator in case of abnormal machine operation or conditions for the appropriate operation and inspection.

- Gauges : Indicate operating status of the machine.
 - Warning lamp : Indicate abnormality of the machine.
 - Pilot lamp : Indicate operating status of the machine.
- ※ The monitor installed on this machine does not entirely guarantee the condition of the machine. Daily inspection should be performed according to chapter 6, Maintenance in operator's manual.
- ※ When the monitor provides a warning immediately check the problem, and perform the required action.

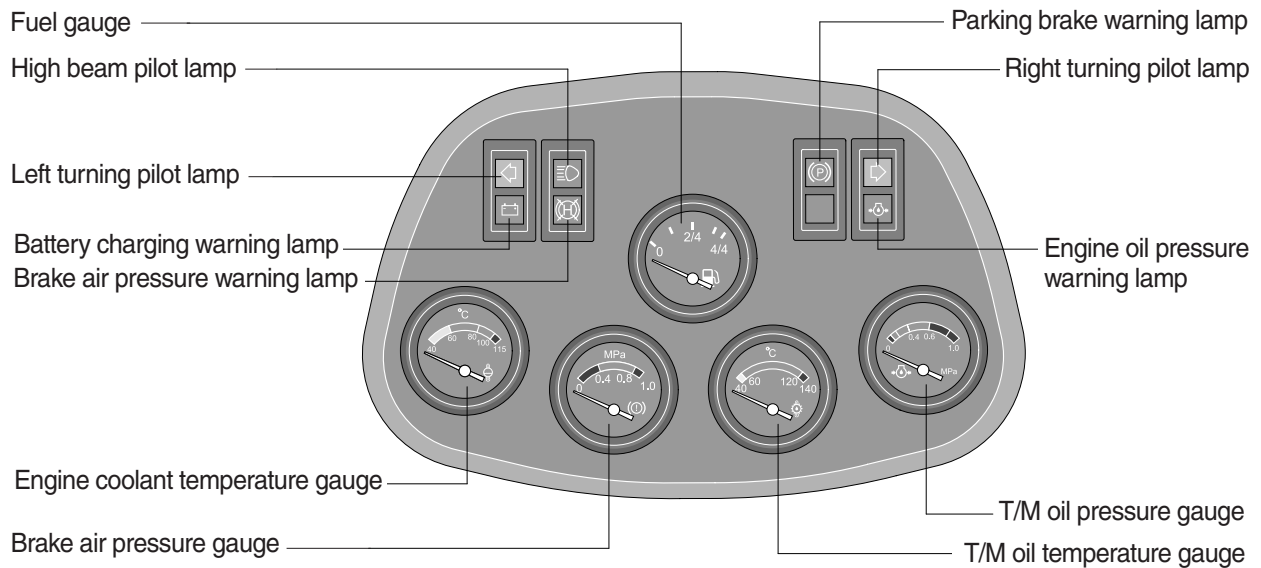

830K3CD02K

1) FUEL GAUGE

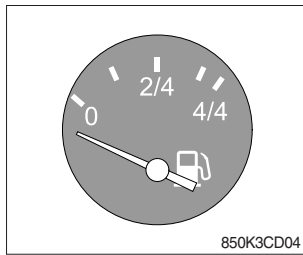

- (1) This gauge indicates the amount of fuel in the fuel tank.
 - (2) Fill the fuel when the indicator moves 0 point, refuel as soon as possible to avoid running out of fuel.
- ※ If the gauge indicates below 0 point even though the machine is on the normal condition, check the electric device as that can be caused by the poor connection of electricity or sensor.

2) ENGINE COOLANT TEMPERATURE GAUGE

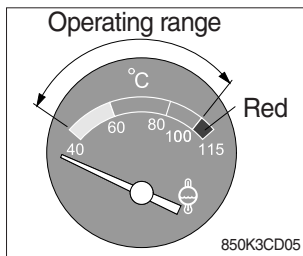

- (1) This gauge indicates the temperature of coolant.
 - Red range : Above 100°C (219°F)
- (2) If the indicator is in operating range, it is normal.
- (3) Keep idling engine at low speed until the indicator is in the operating range.
- (4) If the indicator is in the red range, turn OFF the engine, check the radiator and engine.

3) TRANSMISSION OIL TEMPERATURE GAUGE

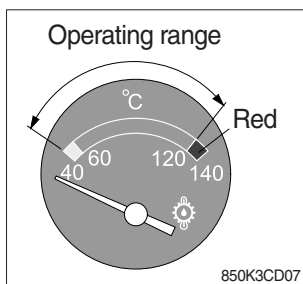

- (1) This gauge indicates the temperature of transmission oil.
 - Red range : Above 120°C (225°F)
- (2) If the indicator is in operating range, it is normal.
- (3) Keep idling engine at low speed until the indicator is in the operating range.
- (4) If the indicator is in the red range, it means the transmission is overheated. Be careful that the indicator does not move into the red range.

4) TRANSMISSION OIL PRESSURE GAUGE

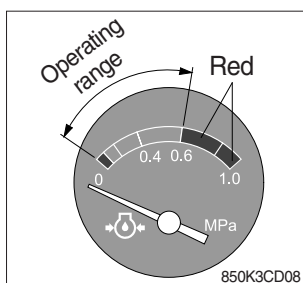

- (1) This gauge indicates the pressure of transmission oil.
- (2) If the indicator is in operating range, it is normal.
- (3) If the indicator is in the red range, stop the engine and check the transmission system.

5) BRAKE AIR PRESSURE GAUGE

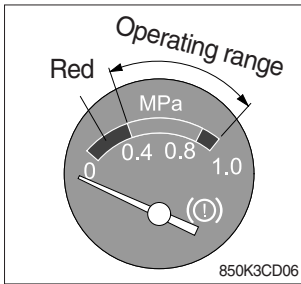

- (1) This gauge indicates the air pressure of service brake.
 - Red range : Below 0.4 MPa
- (2) If the indicator is in operating range, it is normal.
- (3) If the indicator is in the red range, keep idling engine at low speed until the operating range indicates.

6) DIRECTION PILOT LAMP

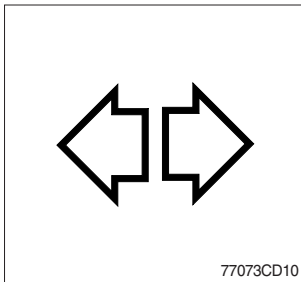

- (1) This lamp flashes when the signal indicator lever is moved.
- (2) When the lamp lights up, the alarm (50 dB) sounds.

7) HIGH BEAM PILOT LAMP

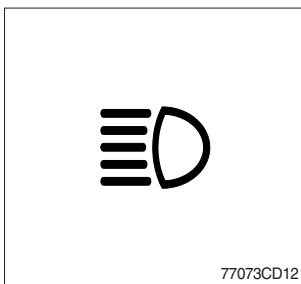

- (1) This lamp works when the illuminating direction is upward.
- (2) This lamp comes ON when the dimmer switch is operated, e.g., when passing another vehicle.

8) PARKING BRAKE WARNING LAMP

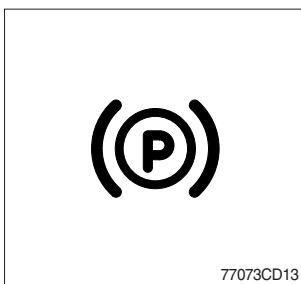

- (1) When the parking brake is actuated, the lamp lights ON.
 - ※ Check the lamp is OFF before driving.

9) BRAKE AIR PRESSURE WARNING LAMP



- (1) The lamp lights ON when the air pressure of service brake drops below the normal range.
- (2) When the lamp is ON, stop the engine and check for its cause.
 - ※ Do not operate until any problems are corrected.

10) ENGINE OIL PRESSURE WARNING LAMP

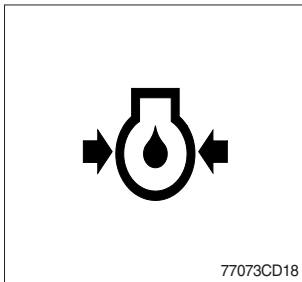

(1) This lamp is comes ON after starting the engine because of the low oil pressure.

(2) If the lamp comes ON during engine operation, shut OFF engine immediately. Check oil level.

11) BATTERY CHARGING WARNING LAMP

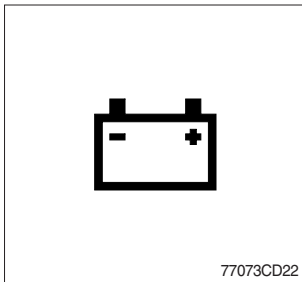

(1) This lamp is ON when key ON, it is turned OFF after starting the engine.

(2) Check the battery charging circuit when this lamp comes ON during engine operation.

2. SWITCHES

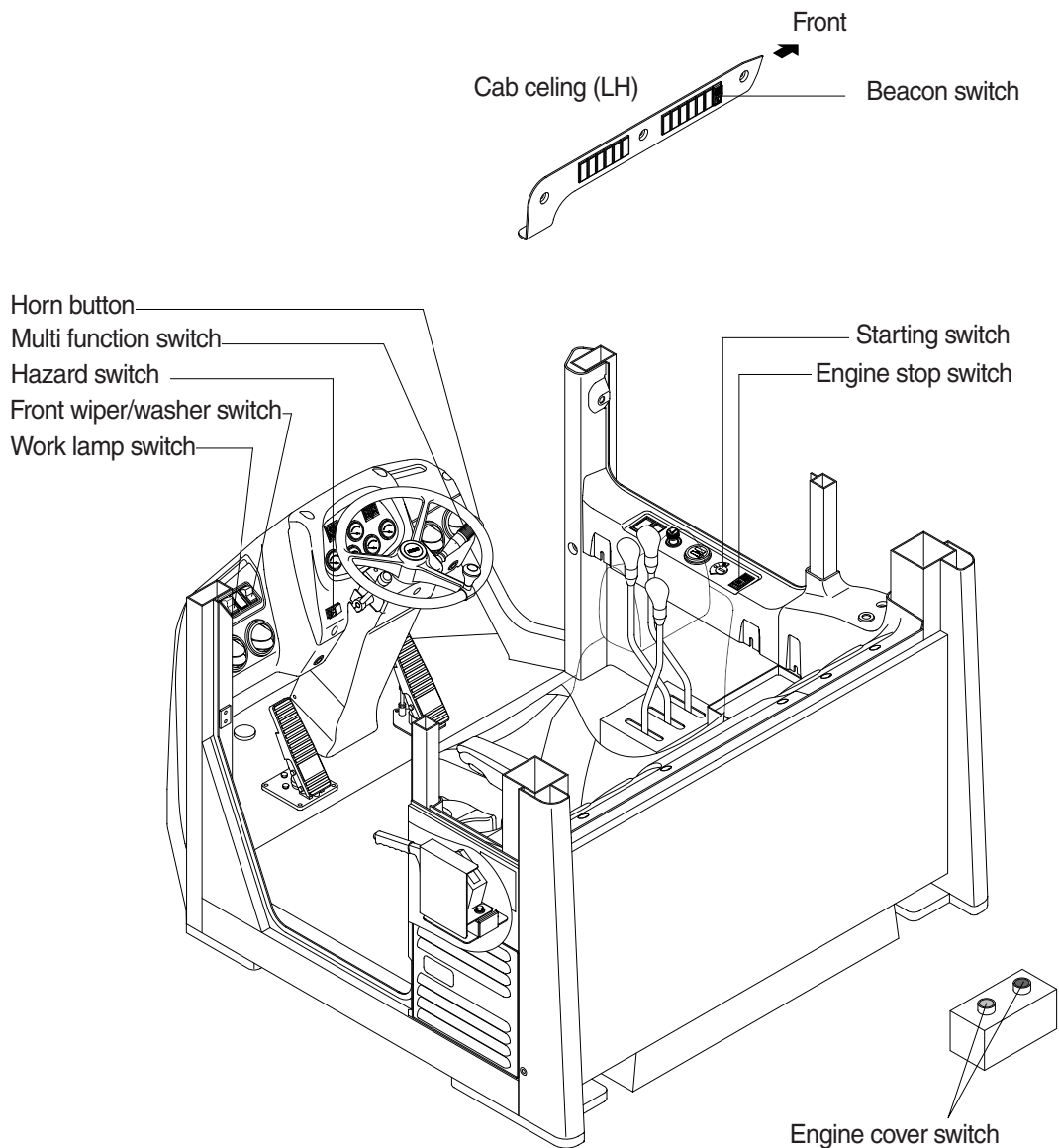

1) STARTING SWITCH

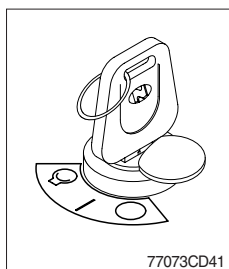

(1) There are three positions, OFF, ON and START.

- ○ (OFF) : None of electrical circuits activate.
- | (ON) : All the systems of machine operate.
- ○ (START) : Use when starting the engine. Release key immediately after starting.

2) HAZARD SWITCH

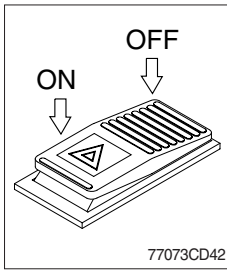

(1) Use for parking, or roading machine.

(2) Both turn signal lights will flash simultaneously.

※ If the switch is left ON for a long time, the battery may be discharged.

3) WORK LAMP SWITCH

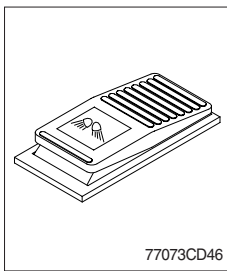

(1) This switch use to operate the front and rear work lamps by two step.

· First step : Front work lamp located on the cab comes ON.

· Second step : Rear work lamp located on the cowl comes ON.

4) FRONT WIPER AND WASHER SWITCH

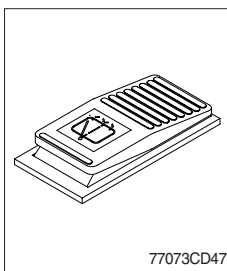

(1) The switch use to operate the front wiper and washer by two step.

· First step : The front wiper operates.

· Second step : The washer liquid is sprayed and the front wiper is operated only while pressing. If release the switch, return to the first step position.

5) BEACON SWITCH (option)

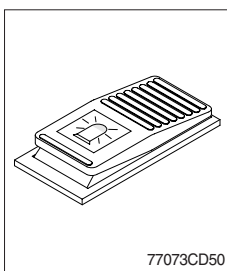

(1) This switch turns ON the rotary light on the cab.

6) HORN BUTTON

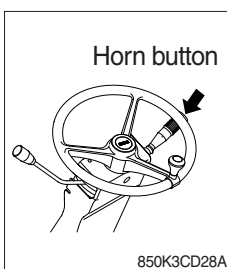

(1) If you press the button on the top of the multifunction switch, the horn will sound.

7) CAB LAMP SWITCH

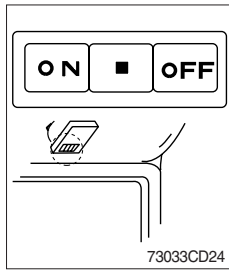

(1) This switch turns ON the cab room lamp.

8) MULTI FUNCTION SWITCH

(1) Dimmer switch

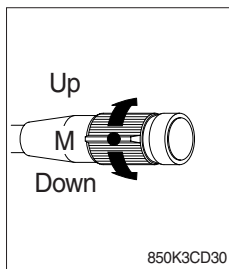

① This switch is used to turn the head lights direction.

② Switch positions

- Up : To flash for passing
- Middle : Head lights low beam ON
- Down : Head lights high beam ON

③ If you release the switch when it's in up position, the switch will return to middle

(2) Turning switch

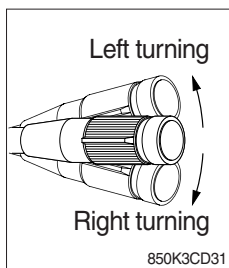

① This switch is used to warn or signal the turning direction of the machine to other vehicles or equipment.

② Push the lever up for turning left, pull the lever down for turning right.

9) ENGINE COVER SWITCH

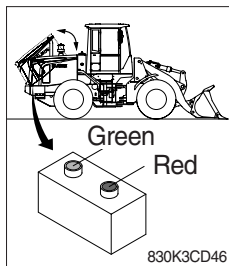

(1) This switch is used to open or close the engine cover.

(2) Turn the starting switch to the ON position, press the button.

- Green button : Open the engine cover
- Red button : Close the engine cover

10) ENGINE STOP SWITCH

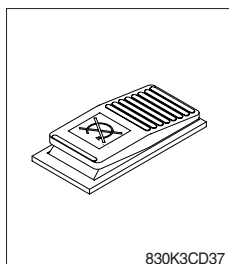

(1) If the switch is pressed, the engine stops immediately.