

GROUP 4 AXLE

1. OUTLINE

1) PRODUCT SURVEY

The axle has two stages reduction structure. It has rational design structure, reliable use performance, long duration of life, etc. It adopts caliper disc brake by pneumatic braking. Braking moment is large and braking is stable and reliable.

2) MAIN PERFORMANCE AND TECHNICAL PARAMETERS

Axle model	Main technical parameters						
	Max. load	Max. input torque	Total ratio	Main ratio	Wheel-end ratio	Braking moment	Oil pressure
ZL30	18500 kg	235 kgf · m (1700 lbf · ft)	20.26	4.222	4.8	979 kgf (7080 lbf · ft)	9.8 MPa

3) THE STRUCTURAL CHARACTERISTICS AND WORKING PRINCIPLE

(1) Main structural characteristics

The drive axle is two stages reduction transmission device. The first grade device adopts spiral bevel gear to transmit. Drive axle bears large input torque and has capability of high transmission efficiency and stable working. The second grade device adopts planetary reduction transmission structure (NGW) type. Rigidity of whole movement of drive axle is well and output speed is smooth. Between two grades device, we adopt full-floating axle shaft to connect and transmit power. The structure has overcome that axle housing in the course of working distortion brings the influence to axle shaft transmission.

(2) Working principle

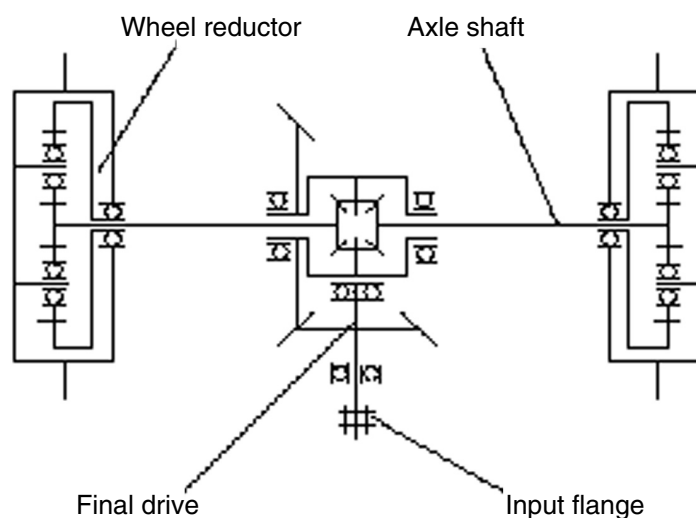

830K2AX100

Power torque of vehicle is inputted by drive shaft from input flange of drive axle. Final drive changes rotary direction to drive driven spiral bevel gear and differential case to rotate after it does reduction and differential. Differential case drives cross pin and planet bevel gears to transmit power to axle shaft gears. Axle shaft gears transmit power to two sides wheel-end reducers by axle shafts, finally transmit power to planet carriers after wheel-end reducers do reduction, thereby drive wheels to roll ahead.

Transmission route of drive axle as follows:

Power torque of vehicle → Input flange → Final drive → Differential → Axle shafts → Wheel-end reducers → Wheels.

4) MAINTENANCE

(1) Must lubricate for new drive axle before it is mounted on vehicle.

Recommended the lubricant: SAE85W-90.

When refuel oil, should separately refuel it from oil inlets at bowl of the middle of axle housing and at two sides wheel-end.

· Oil amount

Front axle : 18 ℓ (4.8 U.S.gal)

Real axle : 18 ℓ (4.8 U.S.gal)

(2) Maintenance per 250 hours

- ① Inspect wear condition of braking discs and whether there are destructive wear on them.
- ② Inspect wear condition of braking plates. When the grooves on friction lining have been worn down and don't meet the requirement, should immediately replace.
- ③ Inspect whether oil level at axle housing meets the requirement. If oil level lowers, should refuel oil in time.

(3) Maintenance per 1000 hours

Lubricant in drive axle work per 1000 hours to replace once new oil.

(4) Maintenance per 2000 hours

Should disconnect drive axle to inspect when it has worked for 2000 hours.

- ① Inspect spiral bevel gear pair backlash, mesh and wear condition of final drive.
- ② Inspect wear condition of differential gears and bevel gear washers.
- ③ Inspect wear condition of wheel-end gears.
- ④ Inspect wear condition of wheel-end planet gear needle rollers and bearings.

(6) Requirement of inspection and debugging projects in the course of use

- ① Spiral bevel gear pair backlash is 0.2~0.3 mm. Mesh is >50% both face width and tooth depth. Mesh is at teeth middle. Mesh leans to little end at empty load. Backlash and mesh are adjusted by adding and reducing adjust shims at bearing seat and by adjust nuts at two sides bearings of differential.
- ② Adjustment of bearing clearance on wheel-end hub: Turn locknut tight until hub only rotates with difficulty, then reverse locknut 1/10 turn. Here, hub can rotate freely without jammed phenomenon, obvious axial clearance and oscillatory phenomenon, turn locknut tight with screw last.

5) TROUBLESHOOTING

Parts names	Problem	Cause	Remdy
Final drive and differential	Loud noise	1. Gear backlash is oversize 2. Bearing is worn.	Adjust gear backlash. Replace bearing.
	Housing body early heats	Lubrication is bad. No lubricant or lubricant is excessive.	Refuel lubricant to oil level.
	Periodic unusual sound	1. Gear appears tooth breakage. 2. There is eyewinker inside. 3. Fasteners loose.	Replace gear. Bleed the oil port to inspect. Turn fasteners tight.
	Differential failure	Cross pin breakage.	Replace cross pin.
	Leakage	1. Oil seal ages and wears. 2. Sealant loses its efficiency. 3. Fasteners loose	Replace oil seal. Scrape off old sealant and smear afresh. Turn fasteners tight.
Wheel-end reductions	Wheel-end doesn't rotate	1. Axle shaft breakage. 2. Differential system failure.	Replace axle shaft. Adjust and replace differential system.
	There is unusual sound	1. Gear appears tooth breakage. 2. There is eyewinker inside.	Replace gear. Bleed the oil port to inspect.
	Housing body early heats	Lubrication is bad. No lubricant or lubricant is excessive.	Refuel lubricant to oil level.
Brake	Braking failure	1. Oil line disconnects or is clogged. 2. Piston O-ring ages and wears. 3. Piston and piston cylinder jam. 4. Hydraulic pressure isn't enough.	Connect or replace oil line. Replace O-ring. Replace brake. Inspect oil pump and exhaust gas in oil line.
	Friction lining doesn't release	1. Piston seal ring ages and wears. 2. Oil inlet joint looses. 3. There is casting defect on brake body.	Replace seal ring. Turn oil inlet joint tight. Replace brake body and repair.

6) TRANSPORTATION AND DEPOSIT

- (1) Strictly prohibit to deposit drive axle in the open air. It should be deposited in the room with good ventilation. If lubricant has molded and deteriorated, when use drive axle, should replace new oil.
- (2) Can't knock and savagely handle drive axle in the course of carry and turnover.

8) STRUCTURE

(1) Drive axle assembly

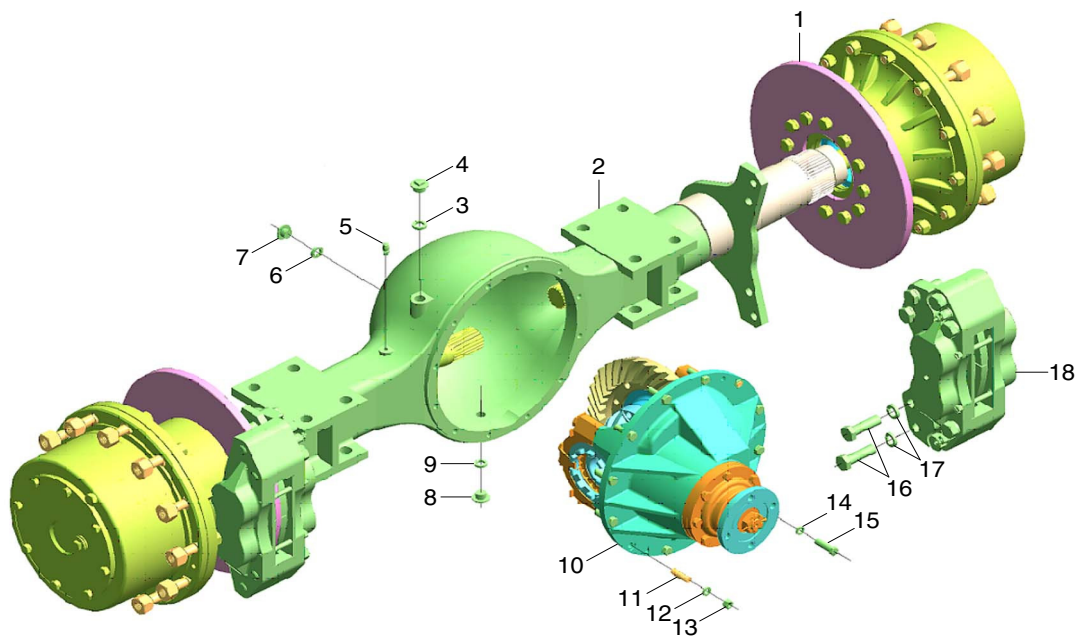

830KPT14

- | | | | | | |
|---|--------------------|----|------------------|----|-----------------|
| 1 | Wheel-end reductor | 7 | Screw plug | 13 | Nut |
| 2 | Axle housing assy | 8 | Screw plug | 14 | Washer |
| 3 | O-ring | 9 | O-ring | 15 | Bolt |
| 4 | Screw plug | 10 | Final drive assy | 16 | Bolt |
| 5 | Exhaust plug | 11 | Double end studs | 17 | Washer |
| 6 | O-ring | 12 | Washer | 18 | Disc brake assy |

(2) Wheel-end reductor

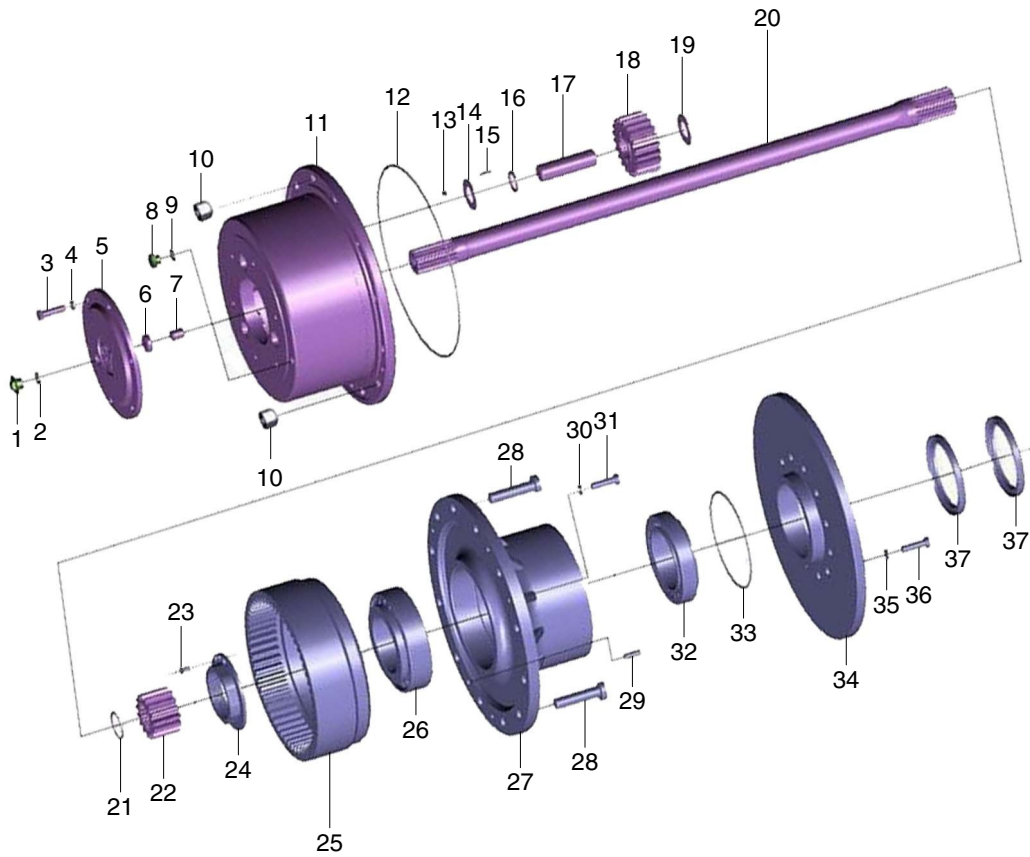

830KPT15

1	Screw plug	13	Steel ball	25	Ring gear
2	O-ring	14	Washer	26	Bearing
3	Bolt	15	Needle roller	27	Hub
4	Washer	16	Spacer	28	Rim bolt
5	Cover	17	Planetary pin	29	Straight pin
6	Retaining plate	18	Planetary gear	30	Washer
7	Adjusting mainstay	19	Washer	31	Bolt
8	Screw plug	20	Short axle shaft	32	Bearing
9	O-ring	21	Criclip	33	O-ring
10	Rim nut	22	Sun gear	34	Braking disc
11	Planetary carrier	23	Screw	35	Washer
12	O-ring	24	Lock nut	36	Bolt
				37	Oil seal

(3) Final drive assembly

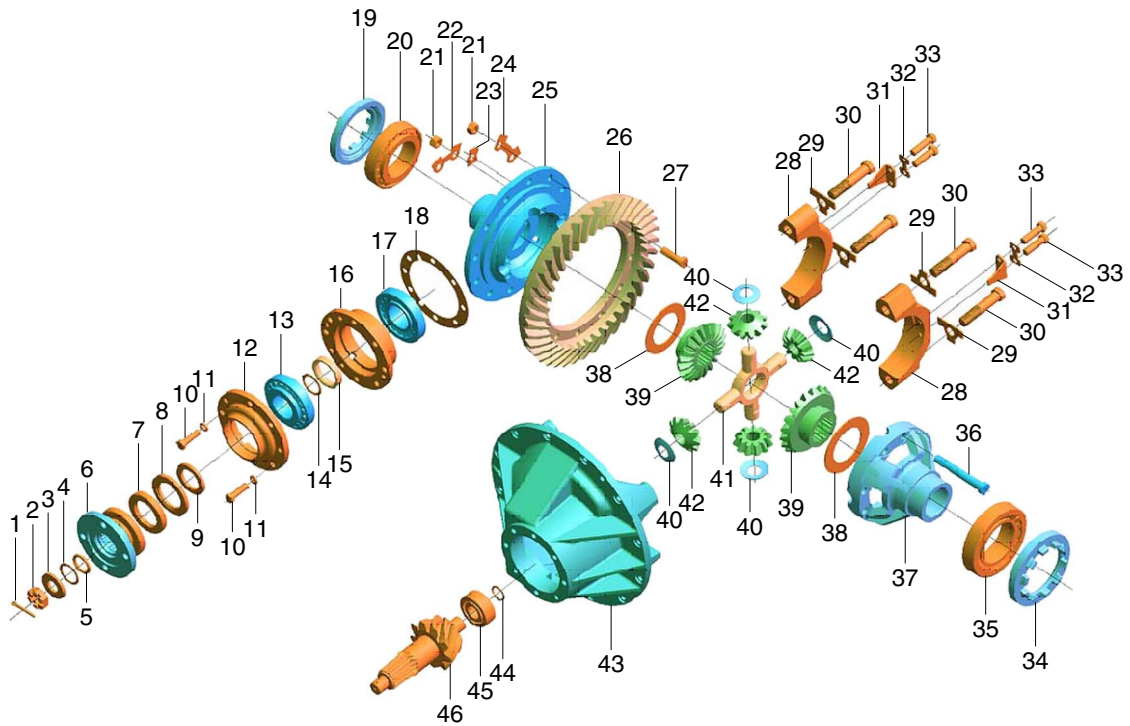

830KPT16

1	Cover	17	Bearing	33	Bolt
2	Nut	18	Adjust shim	34	Adjust nut
3	Washer	19	Adjust nut	35	Bearing
4	Baffle plate	20	Bearing	36	Bolt
5	O-ring	21	Nut	37	Right differential case
6	Input flange	22	Lock plate	38	Thrust washer
7	Oil seal	23	Lock plate	39	Axle shaft gear
8	Oil seal	24	Lock plate	40	Thrust wahser
9	Thrust washer	25	Differential case	41	Cross pin
10	Bolt	26	Driven bevel gear	42	Planetary bevel gear
11	Washer	27	Bolt	43	Final drive housing
12	Bolt	28	Diff bearing cap	44	Criclip
13	Bearing	29	Left differential case	45	Bearing
14	Adjust shim	30	Bolt	46	Driving gear
15	Spacer	31	Lock plate	46	Driving gear
16	Bearing seat	32	Lock plate		

(4) Brake assembly

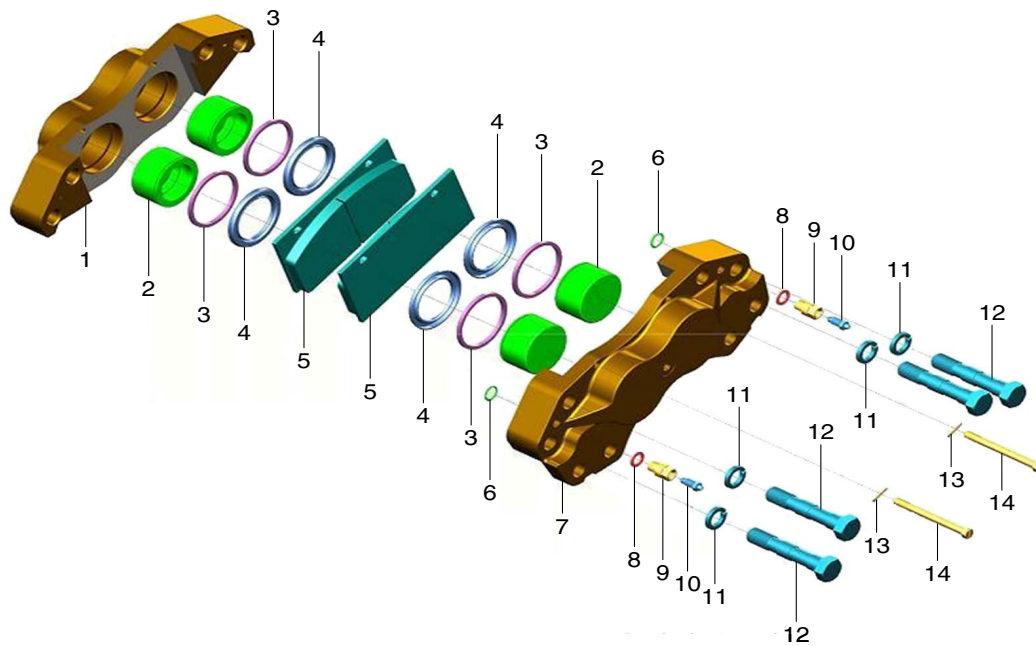

830KPT17

- | | | | | | |
|---|------------------|----|--------------|----|-----------|
| 1 | Outside brake | 6 | O-ring | 11 | Washer |
| 2 | Piston | 7 | Inside brake | 12 | Bolt |
| 3 | Square seal ring | 8 | Washer | 13 | Split pin |
| 4 | Dust shroud | 9 | Joint | 14 | Bolt pin |
| 5 | Braking plate | 10 | Exhaust plug | | |