

# GROUP 7 WORK EQUIPMENT

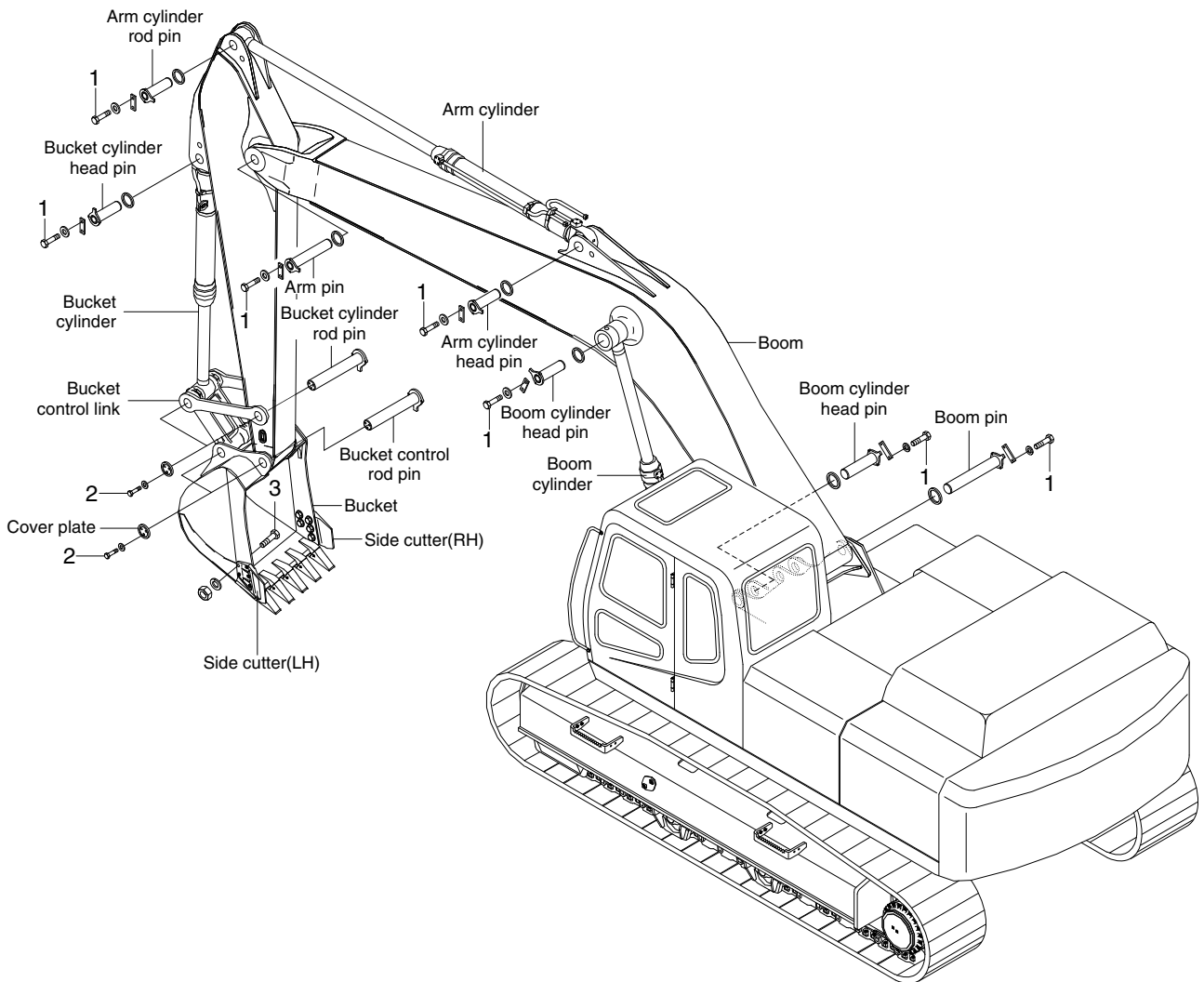

8007ACM15

## · Tightening torque

Item	Size	kgf · m	lbf · ft
1	M16×2.0	29.7±4.5	215±32.5
2	M24×3.0	100±15	723±108

Item	Size	kgf · m	lbf · ft
3	M33×3.5	220±22	1591±159