

## GROUP 3 PILOT CIRCUIT

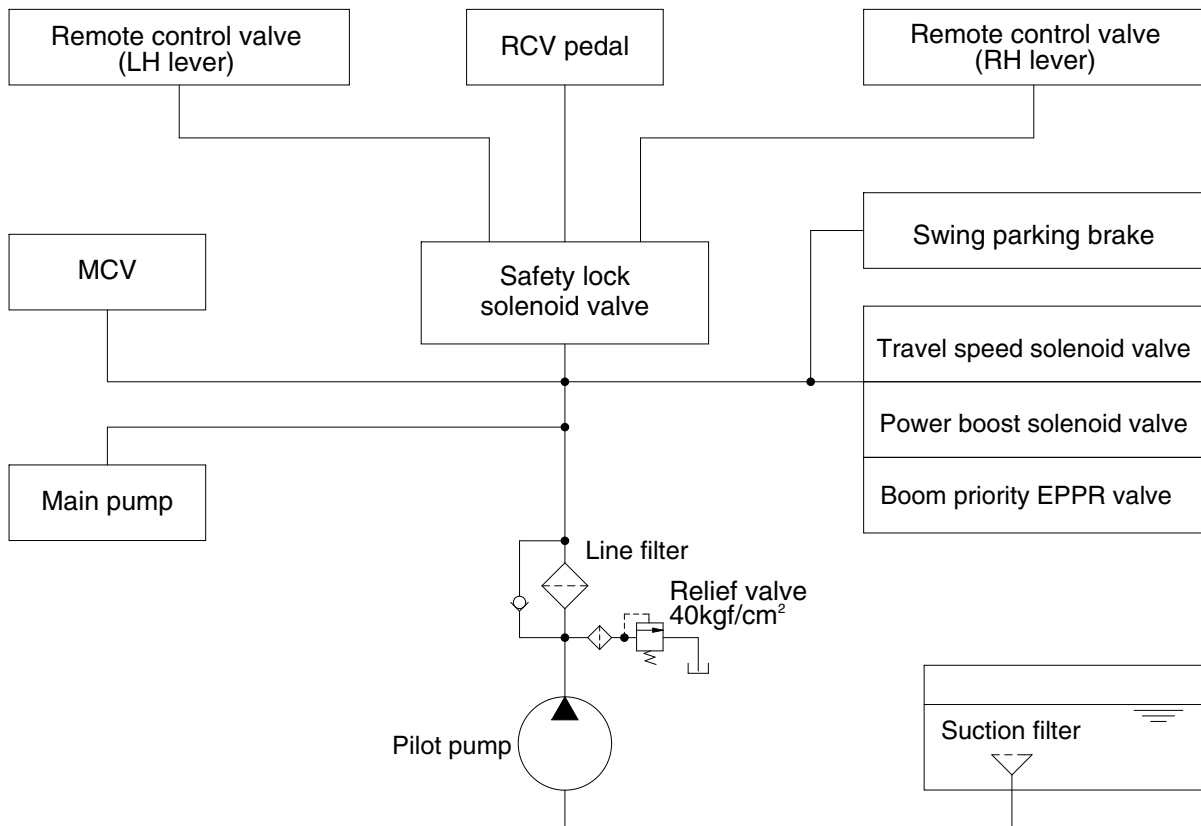

48093CI01

The pilot circuit consists of suction circuit, delivery circuit and return circuit.

The pilot pump is provided with relief valve, receives the oil from the hydraulic tank through the suction filter.

The discharged oil from the pilot pump flows to the remote control valve through line filter, EPPR valve, solenoid valve assemblies, swing parking brake, main control valve and safety lock solenoid valve.

# 1. SUCTION, DELIVERY AND RETURN CIRCUIT

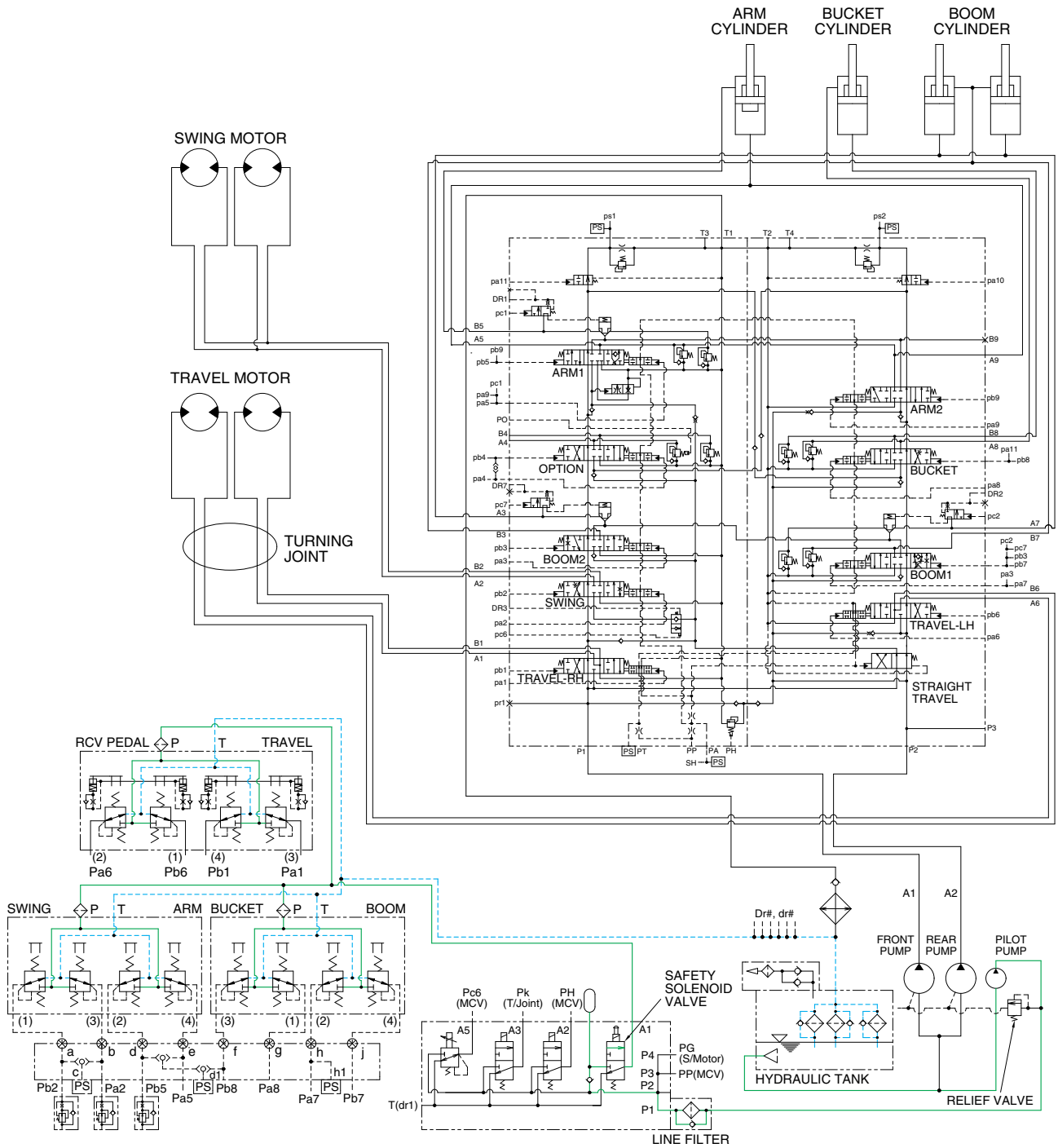

80093HC02

The pilot pump receive oil from the hydraulic tank. The discharged oil from the pilot pump flows to the safety solenoid valve through the line filter. The oil is filtered by the line filter. The pilot relief valve is provided in the pilot pump for limiting the pilot circuit pressure.

The oil filtered by line filter flows remote control valve through safety solenoid valve.

The return oil from remote control valve returned to hydraulic tank.

## 2. SAFETY SOLENOID VALVE (SAFETY LEVER)

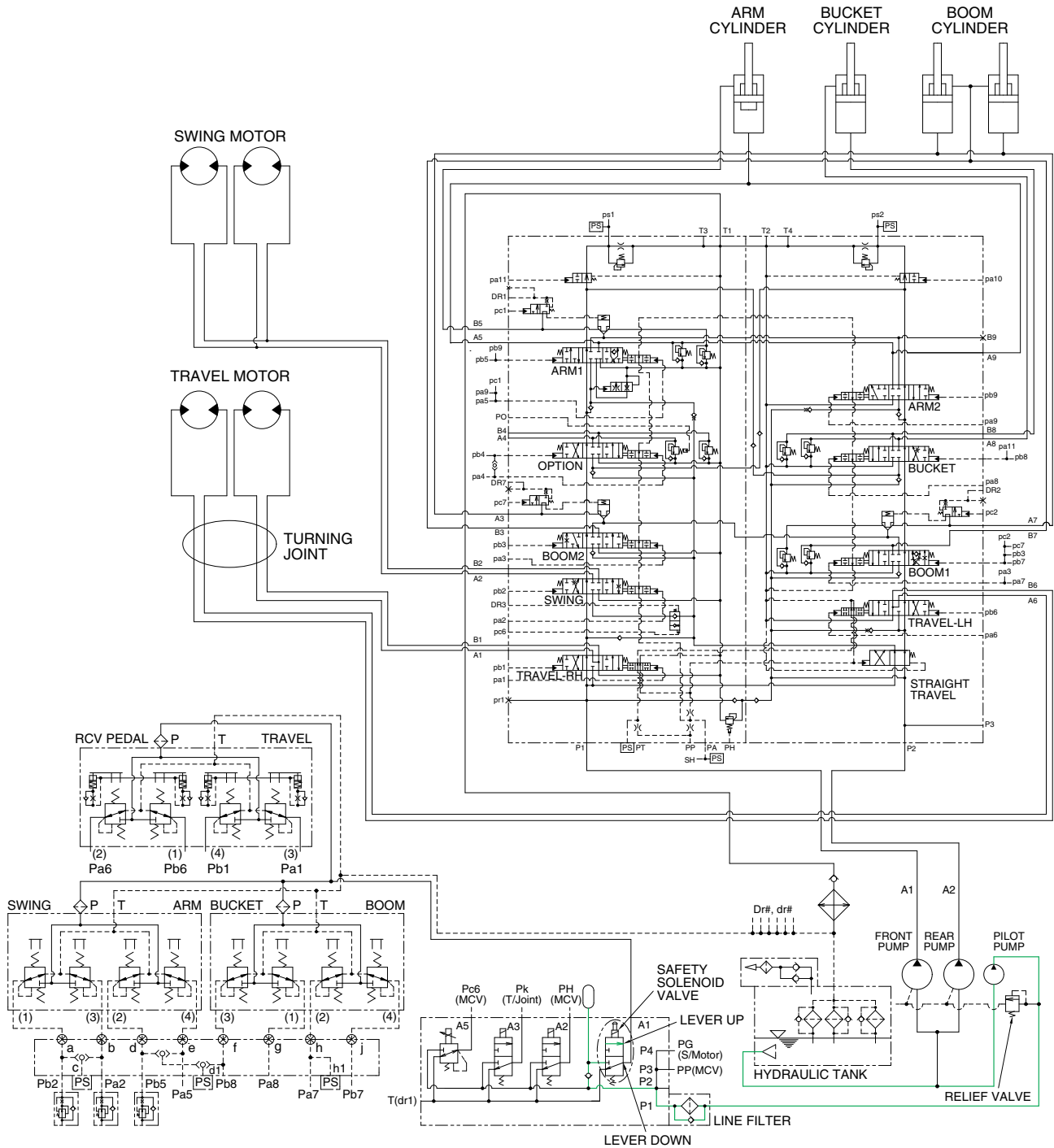

80093HC03

When the lever of the safety solenoid valve is moved downward, oil flows into the remote control valve through solenoid valve and line filter.

When the lever of the safety solenoid valve moved upward, oil does not flows into the remote control valve, because of blocked by the spool.

### 3. BOOM PRIORITY SYSTEM

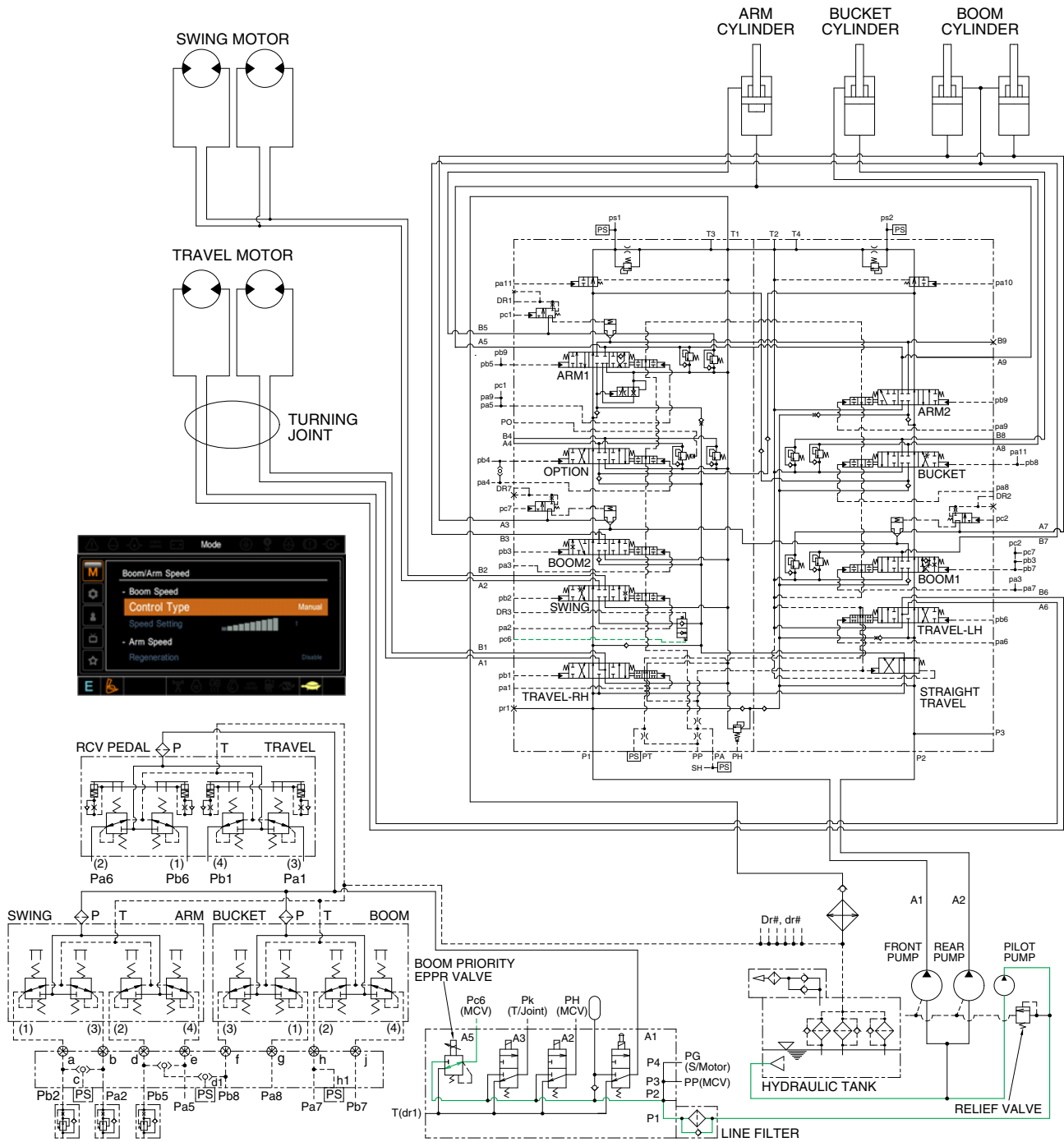

80093HC04

When carrying out the combined operation of swing and boom up, the boom up operating speed is lowered then normal operation.  
 To increase working efficiency, swing speed reducing system is used.  
 The pilot oil from pilot pump flow into **Pc6** port in main control valve through boom EPPR valve. **Pc6** oil pressure moves swing reducing spool to upper direction and oil flow rate to the swing motor decreased.  
 Then, the boom up speed is increased. This is called the boom priority system.

## 4. TRAVEL SPEED CONTROL SYSTEM

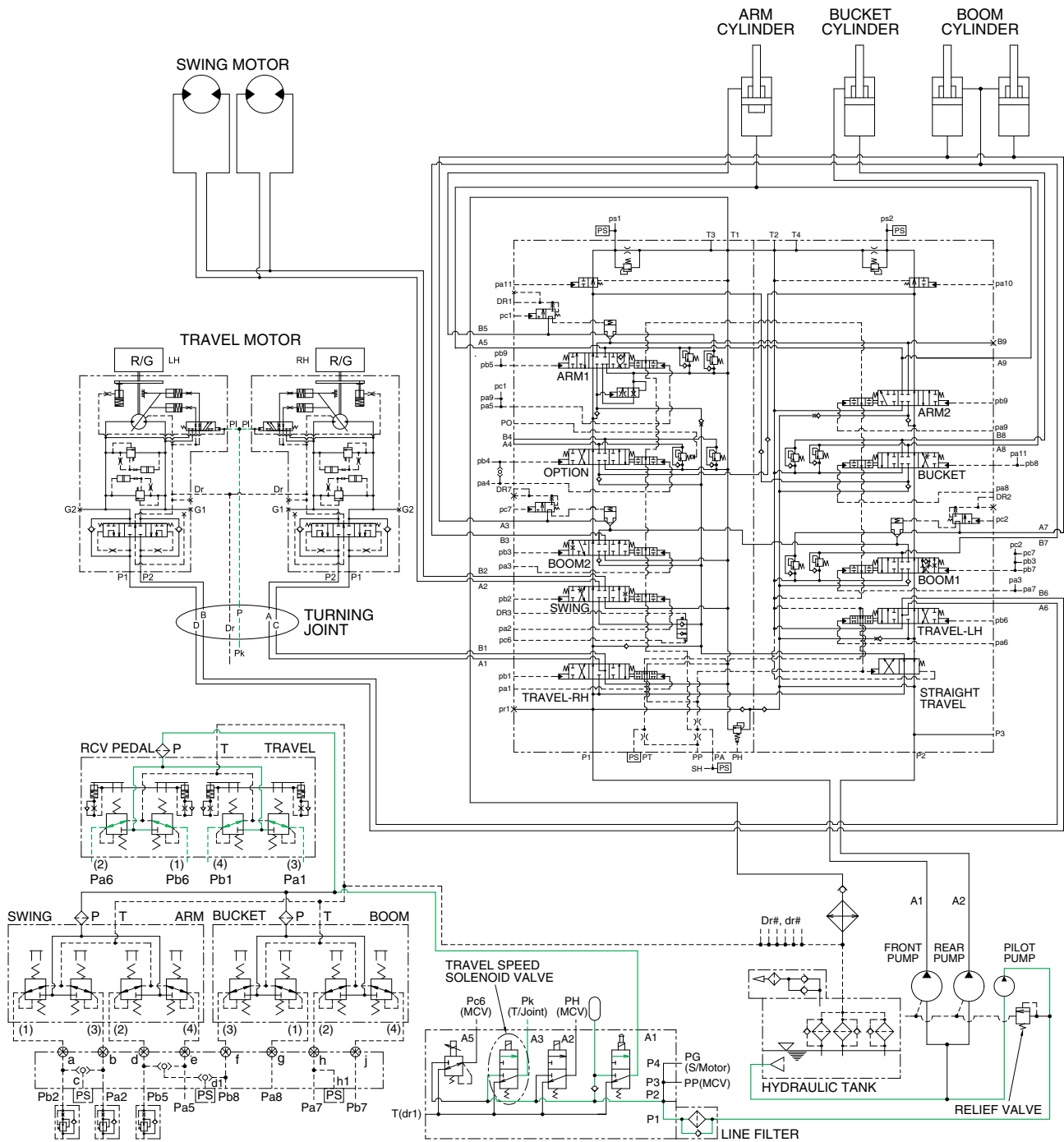

80093HC05

When the travel speed switch is pushed, the travel speed solenoid valve is actuated and the discharged oil from the pilot pump flows to the **Pi** port of pilot valve in the travel motors. As a result, the control piston is pushed by the main oil flow, thus the displacement is minimized. When the travel speed switch is pushed once more, the travel speed solenoid valve is return to original position by the force of spring, the hydraulic oil of **Pi** port returns to the hydraulic tank. As a result, the control piston is returned by the main oil flow, thus the displacement is maximized.

## 5. MAIN RELIEF PRESSURE CHANGE CIRCUIT

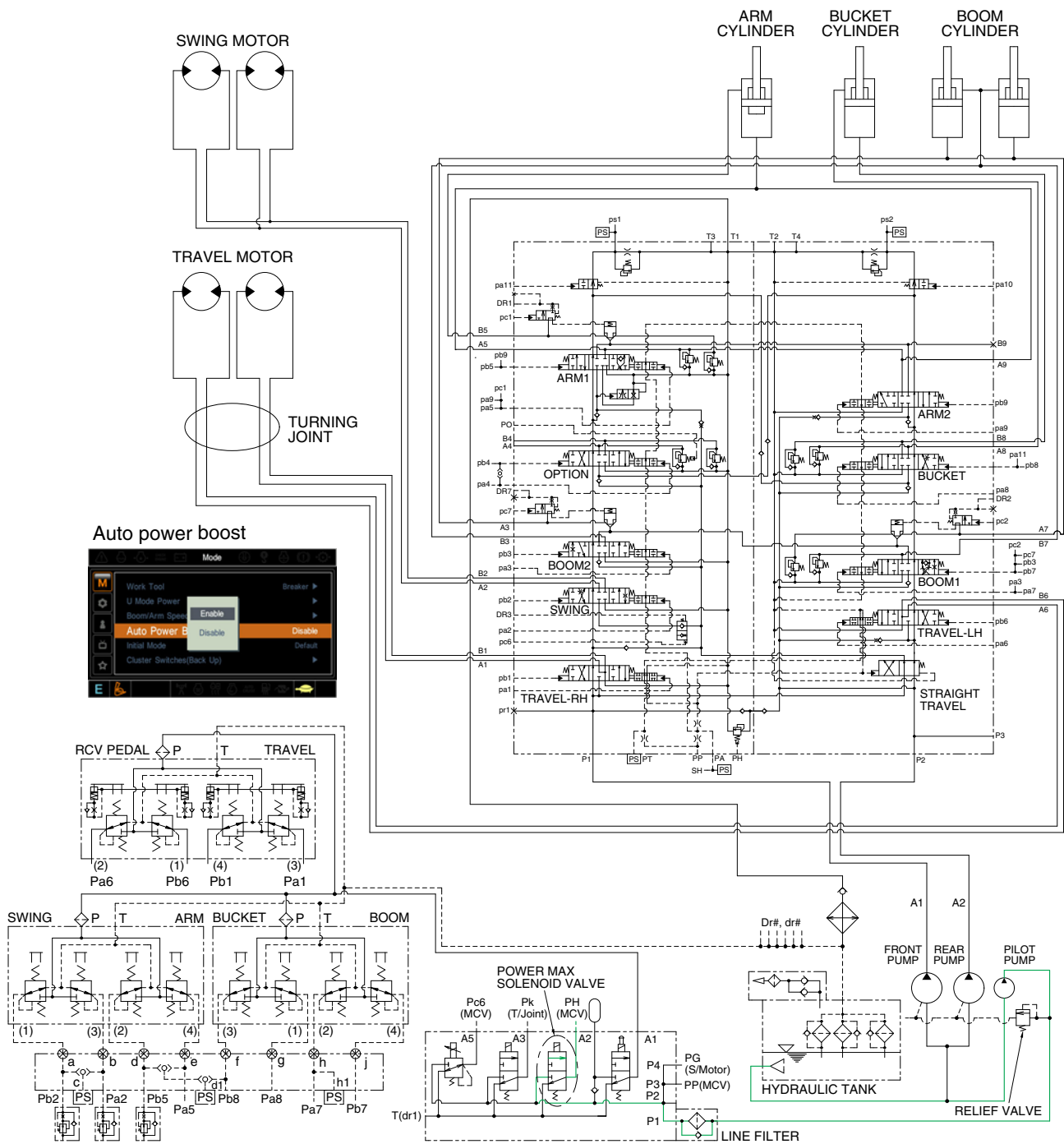

80093HC06

When the power max switch on the left control lever is pushed ON, the power max solenoid valve is actuated, the discharged oil from the pilot pump flow into PH port of the main relief valve of main control valve ; Then the setting pressure of the main control valve is raises from 330 kgf/cm<sup>2</sup> to 360 kgf/cm<sup>2</sup> for increasing the digging power. And even when press continuously, it is canceled after 8 seconds.

## 6. SWING PARKING BRAKE RELEASE

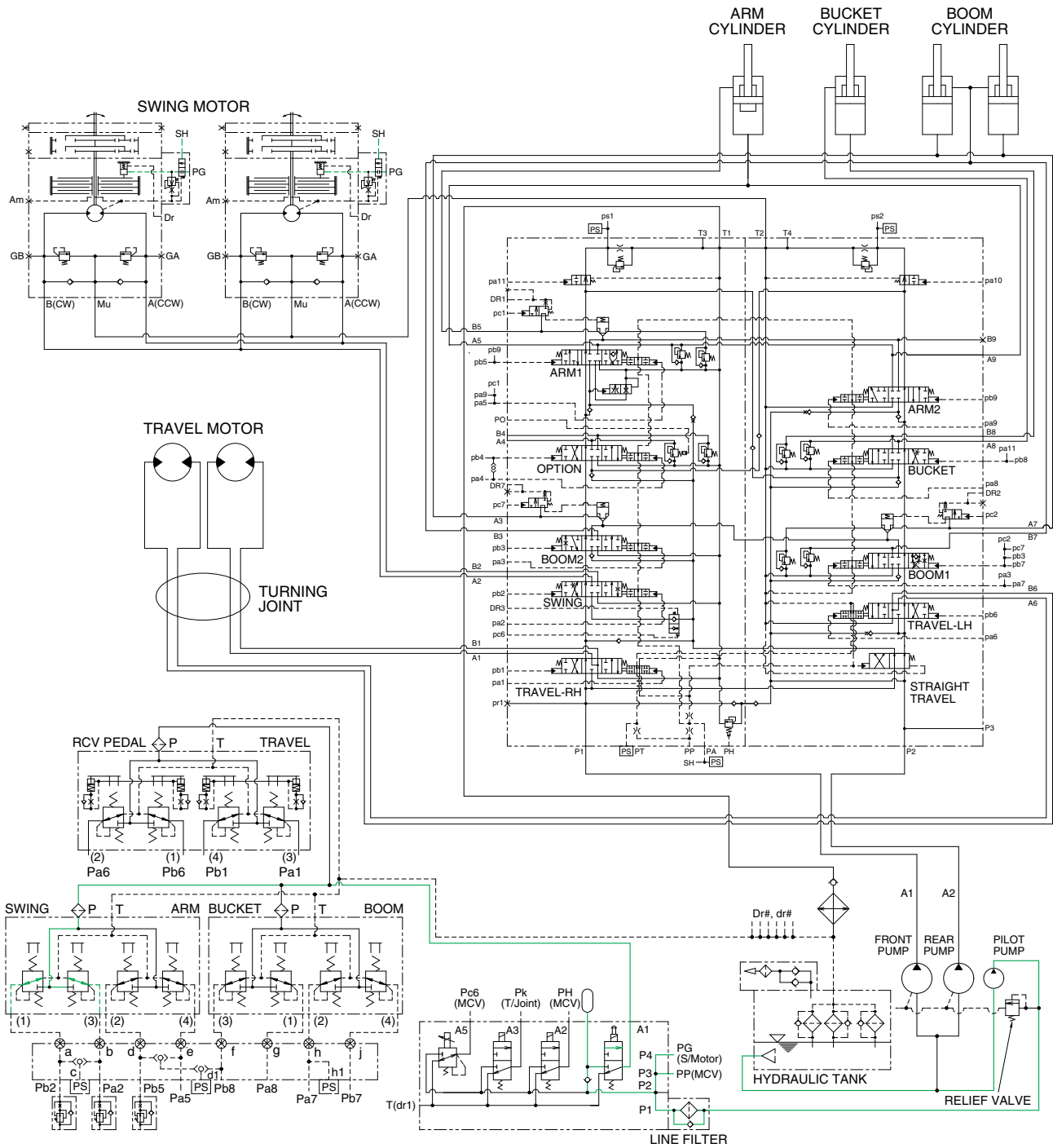

80093HC07

When one of the RCV lever (except travel lever) is tilted, the pilot oil flows into SH port through main control valve.

This pressure moves spool so, discharged oil from pilot valve flows to swing motor PG port.

This pressure is applied to swing motor disc, thus the brake is released.

When all of the RCV lever are set in the neutral position, oil in the swing motor disc cylinder is drained, thus the brake is applied.