

GROUP 4 HYDRAULIC SYSTEM

HYDRAULIC COMPONENTS MOUNTING 1

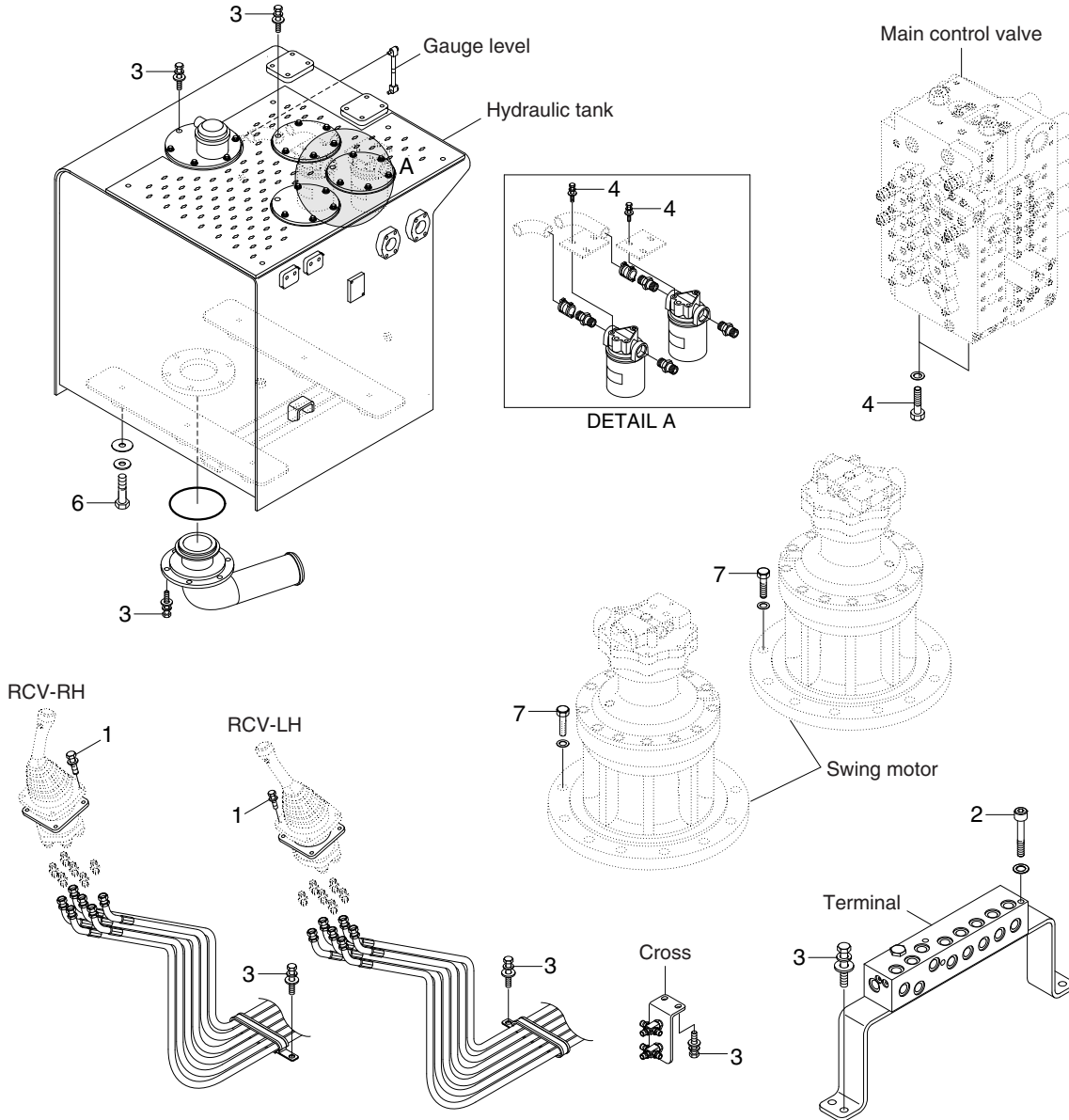

80099CM05

· Tightening torque

Item	Size	kgf · m	lbf · ft
1	M 6×1.0	1.05±0.2	7.6±1.45
2	M 8×1.25	2.5±0.5	18.1±7.1
3	M10×1.5	6.9±1.4	49.9±10.1
4	M12×1.75	12.8±3.0	92.6±21.7

Item	Size	kgf · m	lbf · ft
5	M20×2.5	45±4.5	326±32.5
6	M20×2.5	58±6.0	420±43.4
7	M20×2.5	100±15	723±109

HYDRAULIC COMPONENTS MOUNTING 2

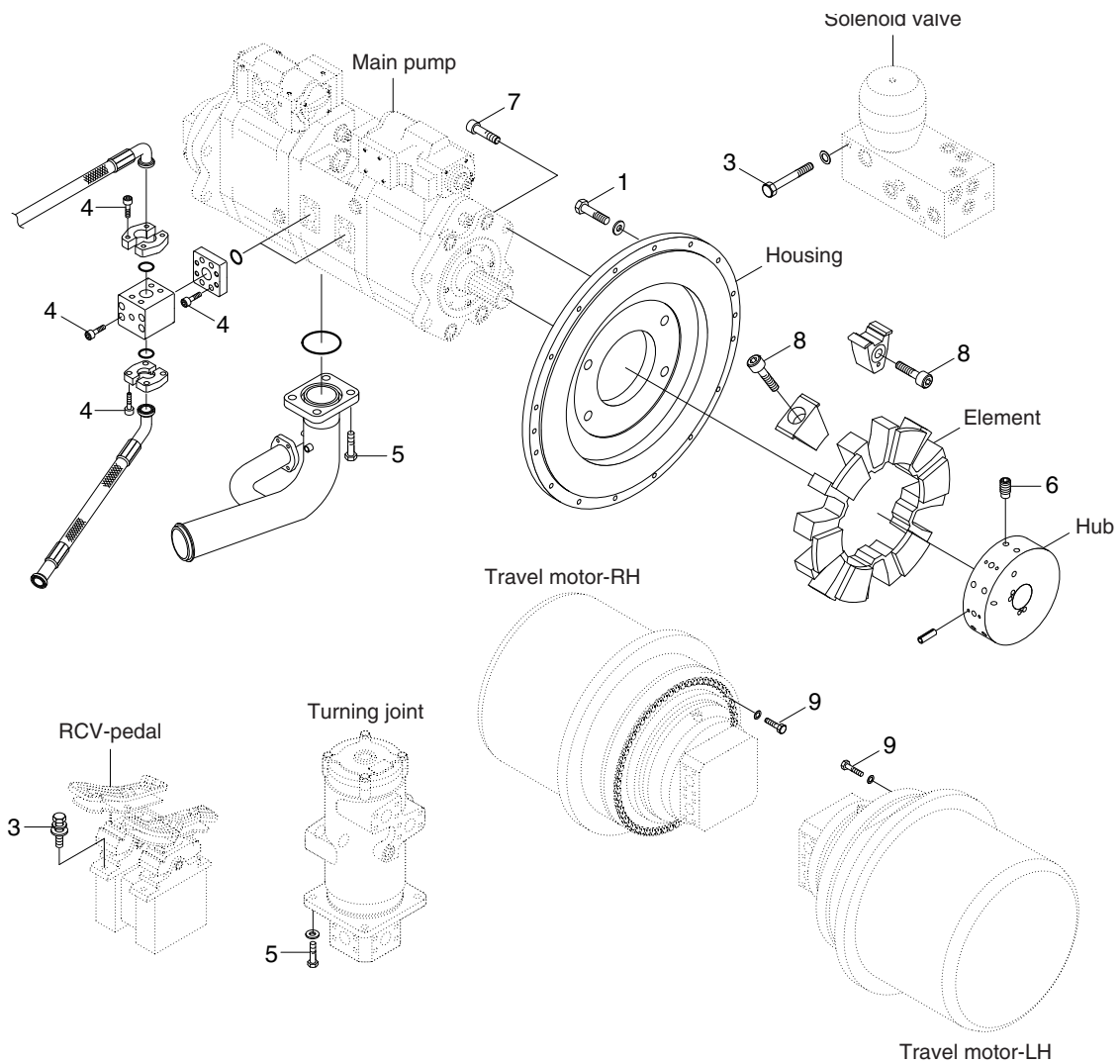

80099CM06

· Tightening torque

Item	Size	kgf · m	lbf · ft
1	M 8×1.25	13.4±1.3	97±9.4
2	M 8×1.25	2.5±0.5	18.1±3.6
3	M10×1.5	6.9±1.4	49.9±10.1
4	M12×1.75	12.8±3.0	92.6±21.7
5	M16×2.0	29.7±4.5	215±32.5

Item	Size	kgf · m	lbf · ft
5	M20×2.5	21.4±1.0	154.8±7.2
6	M24×3.0	80±8.0	579±57.9
7	M24×3.0	89.2±2.5	645±18.1
8	M30×3.0	100±8.0	725±57.9

HYDRAULIC COMPONENTS MOUNTING 3

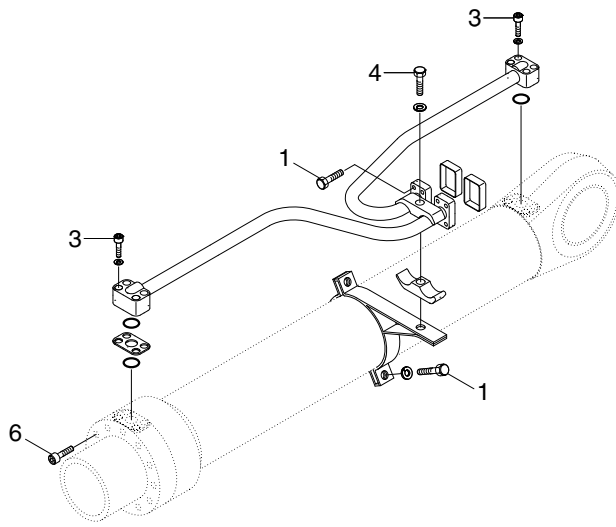

BOOM CYLINDER

Solenoid valve

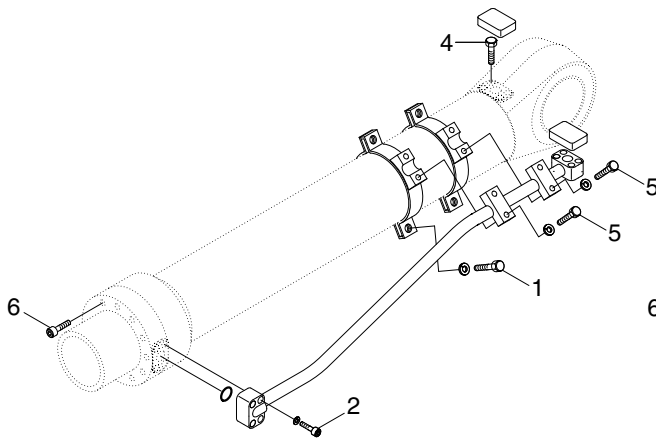
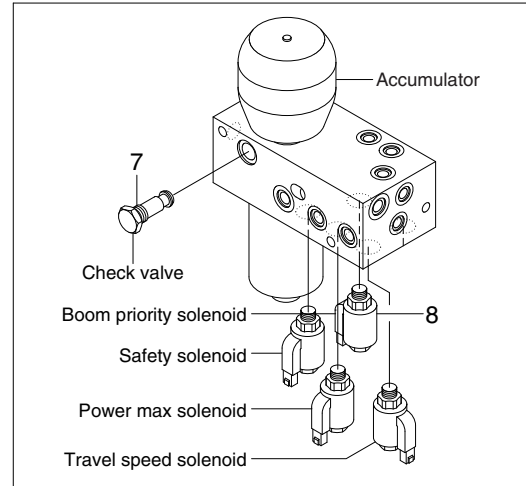

ARM CYLINDER

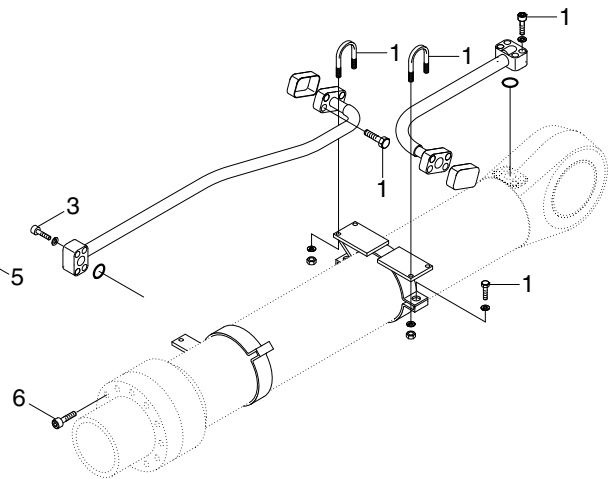

BUCKET CYLINDER

80099CM07

· Tightening torque

Item	Size	kgf · m	lbf · ft
1	M12×1.75	3.25±2.5	23.1±18.1
2	M12×1.75	11.4±0.4	82.5±2.9
3	M14×2.0	14.5±0.5	105±3.6
4	M16×2.0	15.5±0.5	112±3.6

Item	Size	kgf · m	lbf · ft
5	M16×2.0	8±0.6	57.9±4.3
6	M27×3.0	88±1.0	637±7.2
7	M22×2.5	4.1	29.6
8	M22×3.0	5.1	36.9