

SECTION 4 ELECTRICAL SYSTEM

Group 1 Component Location	4-1
Group 2 Electrical Circuit	4-3
Group 3 Electrical Component Specification	4-21
Group 4 Connectors	4-29

SECTION 4 ELECTRICAL SYSTEM

GROUP 1 COMPONENT LOCATION

1. LOCATION 1

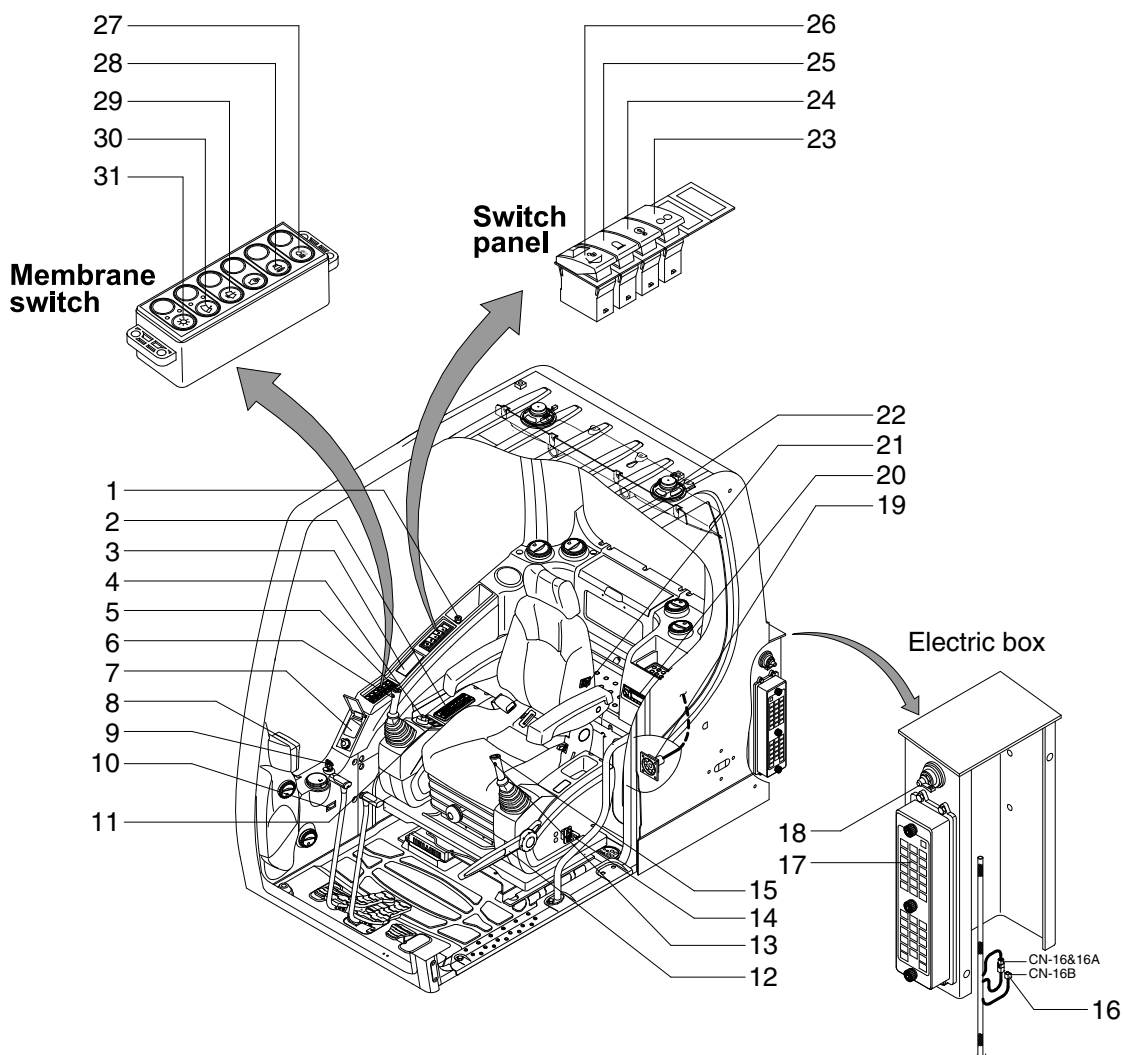

80094EL01

- | | | |
|--------------------------------|---------------------------------|--------------------------------------|
| 1 Cigar light | 12 Safety lever | 22 Speaker |
| 2 Aircon & heater switch panel | 13 Power max switch | 23 Central grease lubrication switch |
| 3 Remote controller | 14 Emergency engine stop switch | 24 Overload switch |
| 4 Accel dial switch | 15 One touch decel switch | 25 Beacon switch |
| 5 Horn switch | 16 Emergency engine connector | 26 Quick clamp switch |
| 6 Breaker operation switch | 17 Fuse box | 27 Cab light switch |
| 7 Handsfree | 18 Master switch | 28 Travel alarm switch |
| 8 Cluster | 19 RS232 & J1939 service socket | 29 Washer switch |
| 9 Starting switch | 20 Radio & USB player | 30 Wiper switch |
| 10 Service meter | 21 Heated seat switch | 31 Main light switch |
| 11 Air compressor switch | | |

2. LOCATION 2

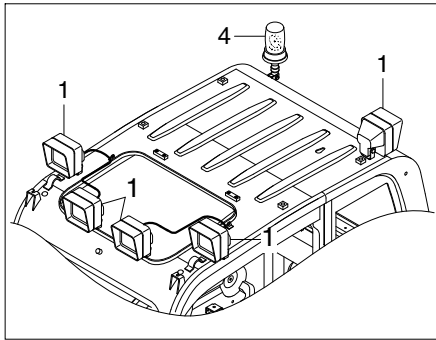

CAB

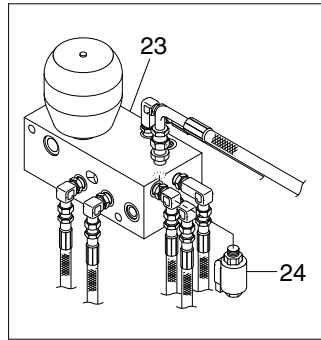

SOLENOID VALVE

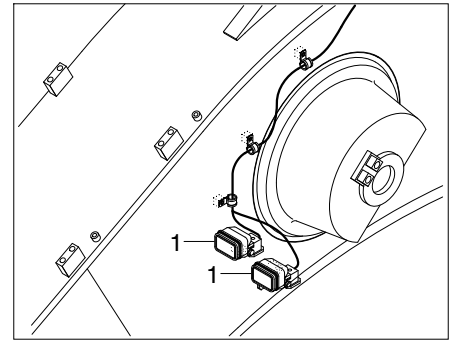

BOOM

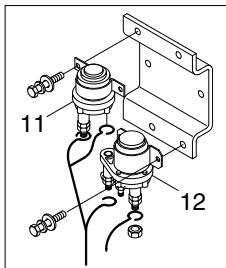

DETAIL A

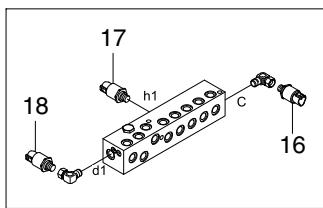
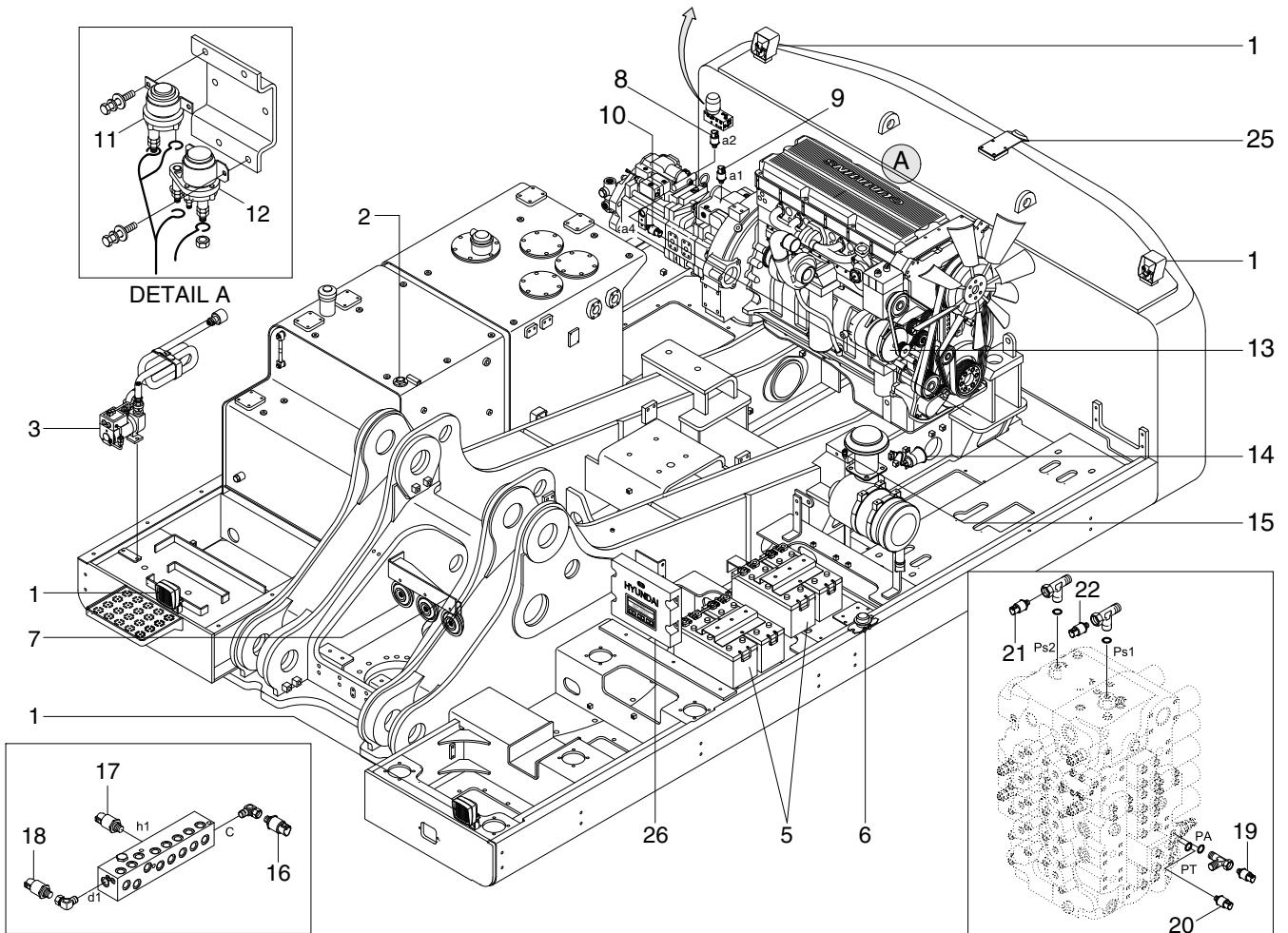

SHUTTLE BLOCK

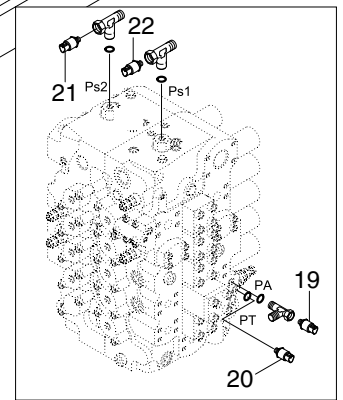

MAIN CONTROL VALVE

80094EL02

- | | | |
|----------------------|------------------------------------|-----------------------------------|
| 1 Lamp | 10 EPPR sensor | 19 Attach pressure sensor |
| 2 Fuel sender | 11 Start relay | 20 Travel pressure sensor |
| 3 Fuel filler pump | 12 Heater relay | 21 Nega control 1 pressure sensor |
| 4 Beacon lamp | 13 Alternator | 22 Nega control 2 pressure sensor |
| 5 Battery | 14 Travel alarm buzzer | 23 Solenoid valve |
| 6 Battery relay | 15 Air cleaner switch | 24 Boom priority EPPR valve |
| 7 Horn | 16 Swing pressure sensor | 25 Rear view camera |
| 8 P1 pressure sensor | 17 Boom up pressure sensor | 26 MCU |
| 9 P2 pressure sensor | 18 Arm / bucket in pressure sensor | |