

## GROUP 9 BOOM, ARM AND BUCKET CYLINDER

### 1. REMOVAL AND INSTALL

#### 1) BUCKET CYLINDER

##### (1) Removal

- ※ Expand the arm and bucket fully, lower the work equipment to the ground and stop the engine.
- ※ Operate the control levers and pedals several times to release the remaining pressure in the hydraulic piping.

##### ▲ Loosen the breather slowly to release the pressure inside the hydraulic tank.

- ※ Escaping fluid under pressure can penetrate the skin causing serious injury. Fit blind plugs in the hoses after disconnecting them, to prevent dirt or dust from entering.

- ① Set block between bucket cylinder and arm.

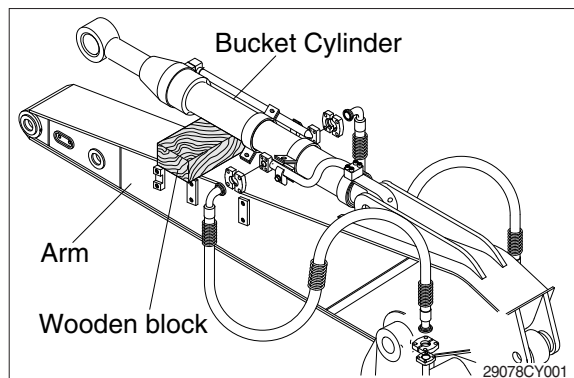

- ② Remove bolt (2), stopper (3) and pull out pin (1).

- ※ Tie the rod with wire to prevent it from coming out.

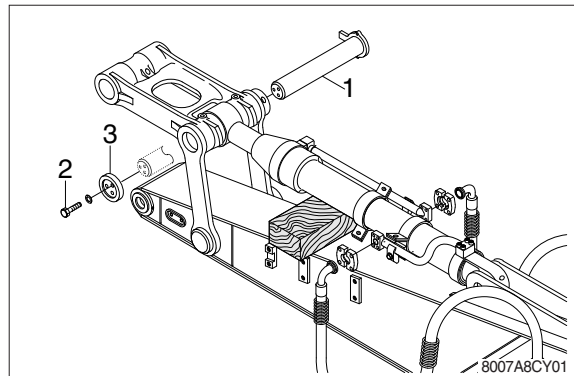

- ③ Disconnect bucket cylinder hoses (4) and put plugs (5) on cylinder pipe.

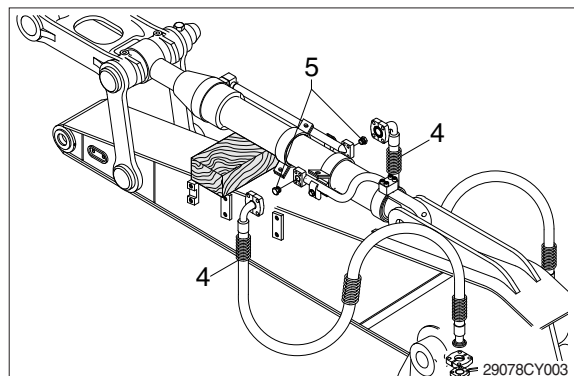

- ④ Sling bucket cylinder assembly (8) and remove bolt (6) then pull out pin (5).
- ⑤ Remove bucket cylinder assembly (8).
  - Weight : 760 kg (1680 lb)

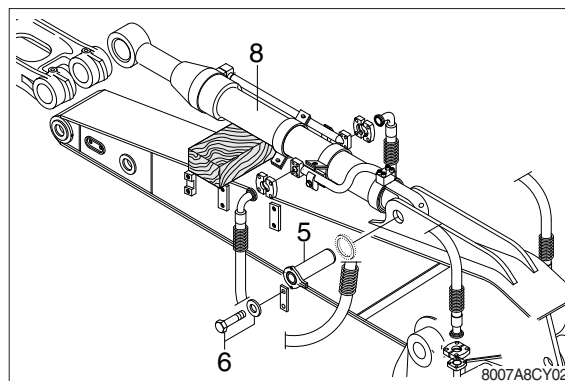

## (2) Install

- ① Carry out installation in the reverse order to removal.
- ▲ When aligning the mounting position of the pin, do not insert your fingers in the pin hole.**
- ※ Bleed the air from the bucket cylinder.
  - ※ Confirm the hydraulic oil level and check the hydraulic oil leak or not.

## 2) ARM CYLINDER

### (1) Removal

- ※ Expand the arm and bucket fully, lower the work equipment to the ground and stop the engine.
- ※ Operate the control levers and pedals several times to release the remaining pressure in the hydraulic piping.

### ▲ Loosen the breather slowly to release the pressure inside the hydraulic tank.

- ※ Escaping fluid under pressure can penetrate the skin causing serious injury. Fit blind plugs in the hoses after disconnecting them, to prevent dirt or dust from entering.

- ① Set block between arm cylinder and boom.

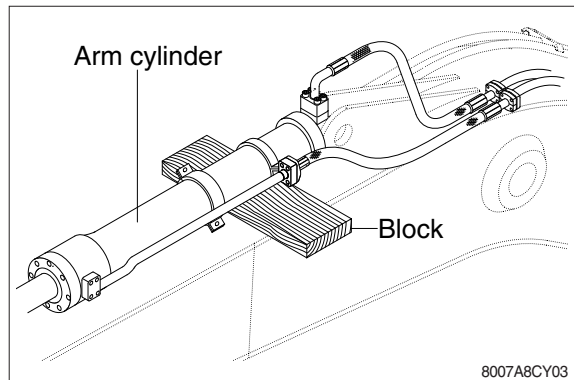

- ② Remove bolt (2) and pull out pin (1).

- ※ Tie the rod with wire to prevent it from coming out.

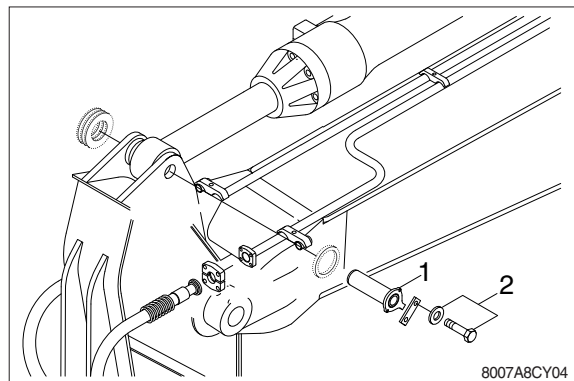

- ③ Disconnect arm cylinder hoses (4) and put plugs on cylinder pipe.

- ④ Disconnect greasing pipings (5).

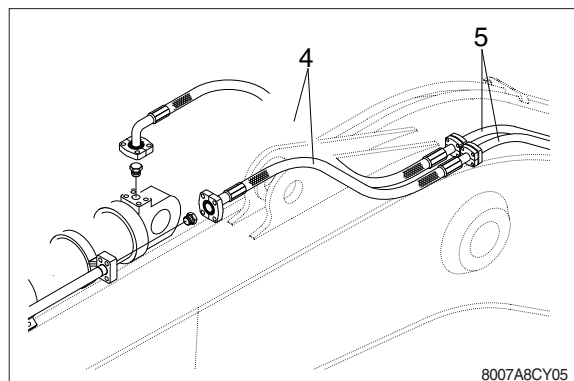

- ⑤ Sling arm assembly (8) and remove bolt (7) then pull out pin (6).
- ⑥ Remove arm cylinder assembly (8).
  - Weight : 950 kg (2090 lb)

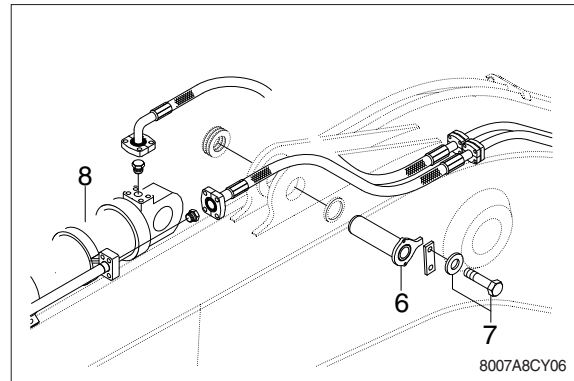

## (2) Install

- ① Carry out installation in the reverse order to removal.
- ▲ When aligning the mounting position of the pin, do not insert your fingers in the pin hole.**
- ※ Bleed the air from the arm cylinder.
  - ※ Confirm the hydraulic oil level and check the hydraulic oil leak or not.

### 3) BOOM CYLINDER

#### (1) Removal

- ※ Expand the arm and bucket fully, lower the work equipment to the ground and stop the engine.
- ※ Operate the control levers and pedals several times to release the remaining pressure in the hydraulic piping.

**▲ Loosen the breather slowly to release the pressure inside the hydraulic tank.**

- ※ Escaping fluid under pressure can penetrate the skin causing serious injury. Fit blind plugs in the hoses after disconnecting them, to prevent dirt or dust from entering.

- ① Disconnect greasing hoses(1).
- ② Sling boom cylinder assembly.

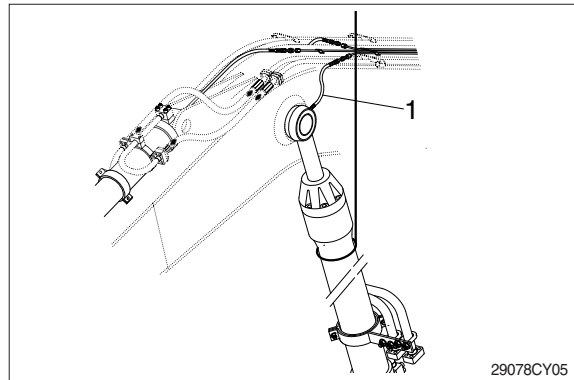

- ③ Remove bolt (4), pin stopper (5) and pull out pin (2).

- ※ Tie the rod with wire to prevent it from coming out.

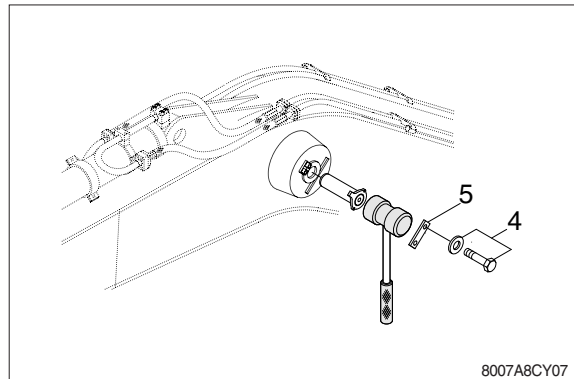

- ④ Lower the boom cylinder assembly (6) on a stand.

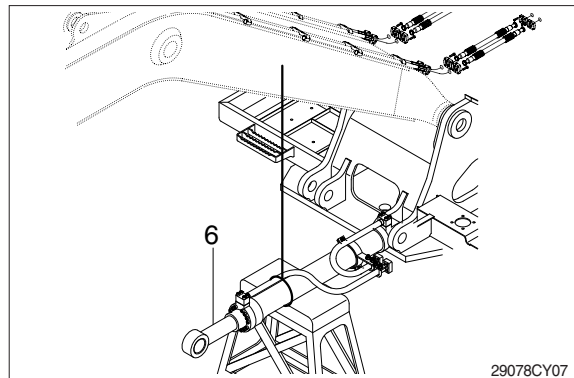

- ⑤ Disconnect boom cylinder hoses (7) and put plugs on cylinder pipe.

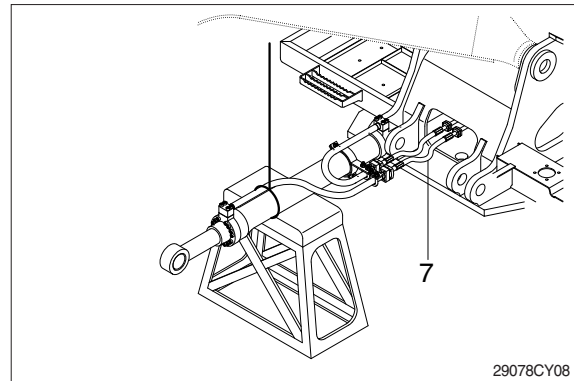

- ⑥ Remove bolt (9) and pull out pin (8).  
⑦ Remove boom cylinder assembly (6).  
· Weight : 1460 kg (3220 lb)

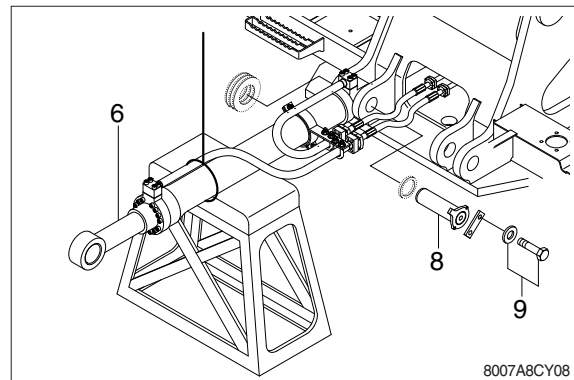

## (2) Install

- ① Carry out installation in the reverse order to removal.

**▲ When aligning the mounting position of the pin, do not insert your fingers in the pin hole.**

- ※ Bleed the air from the boom cylinder.
- ※ Confirmed the hydraulic oil level and check the hydraulic oil leak or not.

## 2. DISASSEMBLY AND ASSEMBLY

### 1) STRUCTURE

#### (1) Bucket cylinder

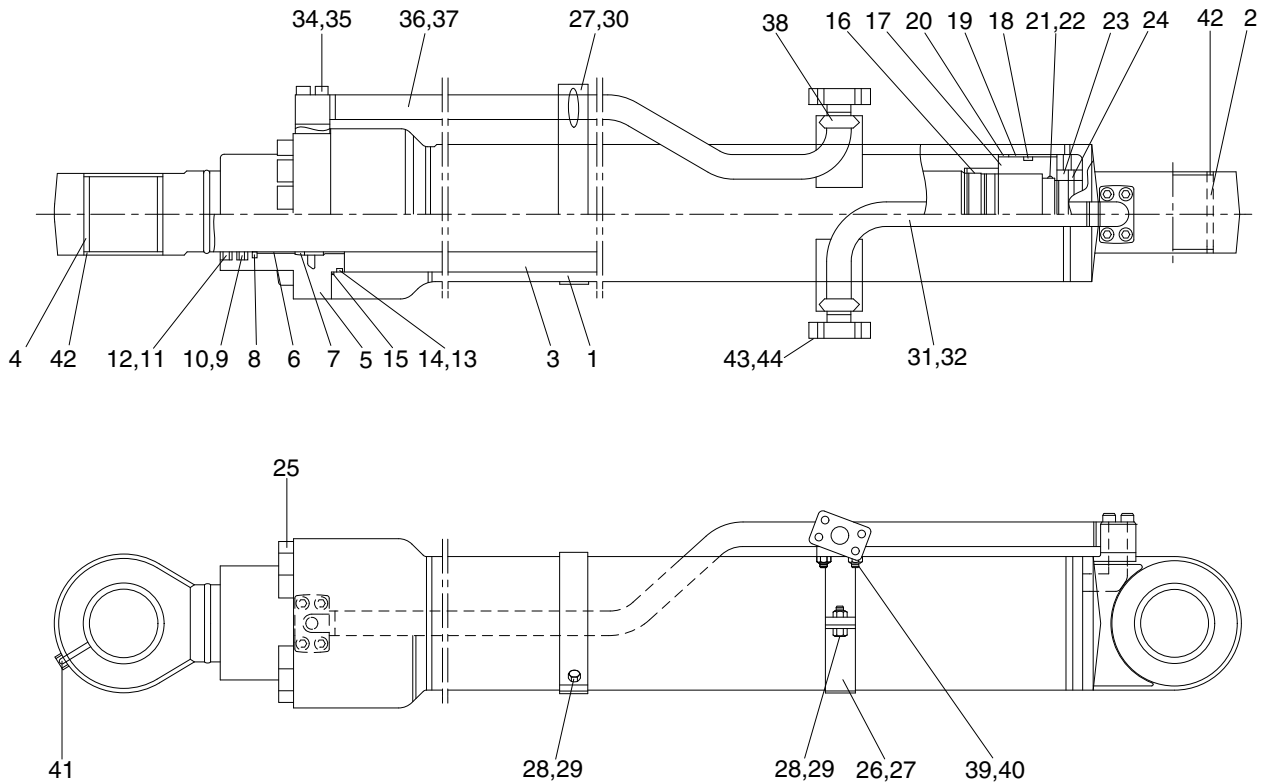

8007A8CY09A

1	Tube assembly	16	Cushion ring	31	Pipe assembly-H
2	Bushing	17	Piston	32	O-ring
3	Rod assembly	18	Slipper seal	33	Spacer
4	Bushing	19	Wear ring	34	Hex socket bolt
5	Rod cover	20	Slyd ring	35	Spring washer
6	DD bushing	21	O-ring	36	Pipe assembly-R
7	Retaining ring	22	Back up ring	37	O-ring
8	Buffer seal	23	Piston nut	38	U-bolt
9	U-packing	24	Set screw	39	Hex nut
10	Back up ring	25	Hex socket bolt	40	Spring washer
11	Dust wiper	26	Pipe band assembly-H	41	Grease nipple
12	Retaining ring	27	Pipe band	42	Pin wiper
13	O-ring	28	Hex bolt	43	Dust cover
14	Back up ring	29	Spring washer	44	Hex bolt
15	O-ring	30	Pipe band assembly-R		

## (2) Arm cylinder

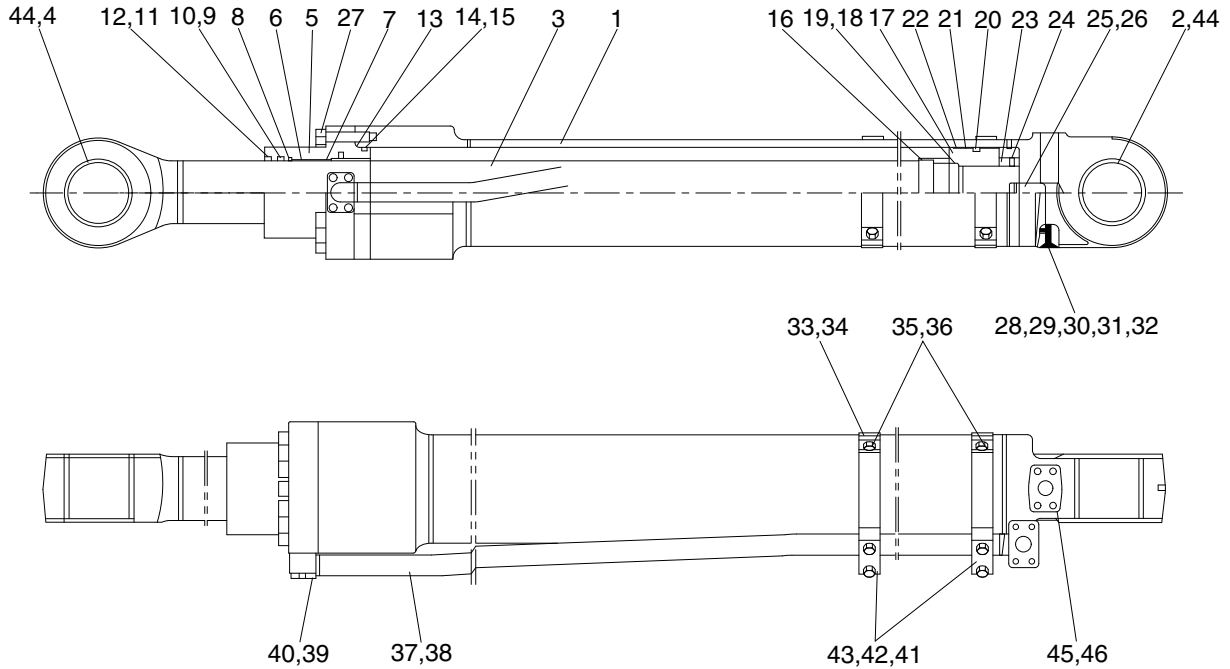

8007A8CY10

- |    |                  |    |                 |    |                    |
|----|------------------|----|-----------------|----|--------------------|
| 1  | Tube assembly    | 17 | Piston          | 33 | Pipe band assembly |
| 2  | Oil less bushing | 18 | Slipper seal    | 34 | Pipe band          |
| 3  | Rod assembly     | 19 | Wear ring       | 35 | Spring washer      |
| 4  | Oil less bushing | 20 | Slyd ring       | 36 | Hex bolt           |
| 5  | Rod cover        | 21 | O-ring          | 37 | Pipe assembly      |
| 6  | DD bushing       | 22 | Back up ring    | 38 | O-ring             |
| 7  | Retaining ring   | 23 | Piston nut      | 39 | Spring washer      |
| 8  | Buffer seal      | 24 | Set screw       | 40 | Hex socket bolt    |
| 9  | U-packing        | 25 | Plunger         | 41 | Pipe clamp         |
| 10 | Back up ring     | 26 | Stop ring       | 42 | Spring washer      |
| 11 | Dust wiper       | 27 | Hex socket bolt | 43 | Hex bolt           |
| 12 | Retaining ring   | 28 | Check valve     | 44 | Pin wiper          |
| 13 | O-ring           | 29 | Spring          | 45 | Dust cover         |
| 14 | Back up ring     | 30 | Spring support  | 46 | Hex bolt           |
| 15 | O-ring           | 31 | O-ring          |    |                    |
| 16 | Cushion ring     | 32 | Plug            |    |                    |



### (3) Boom cylinder

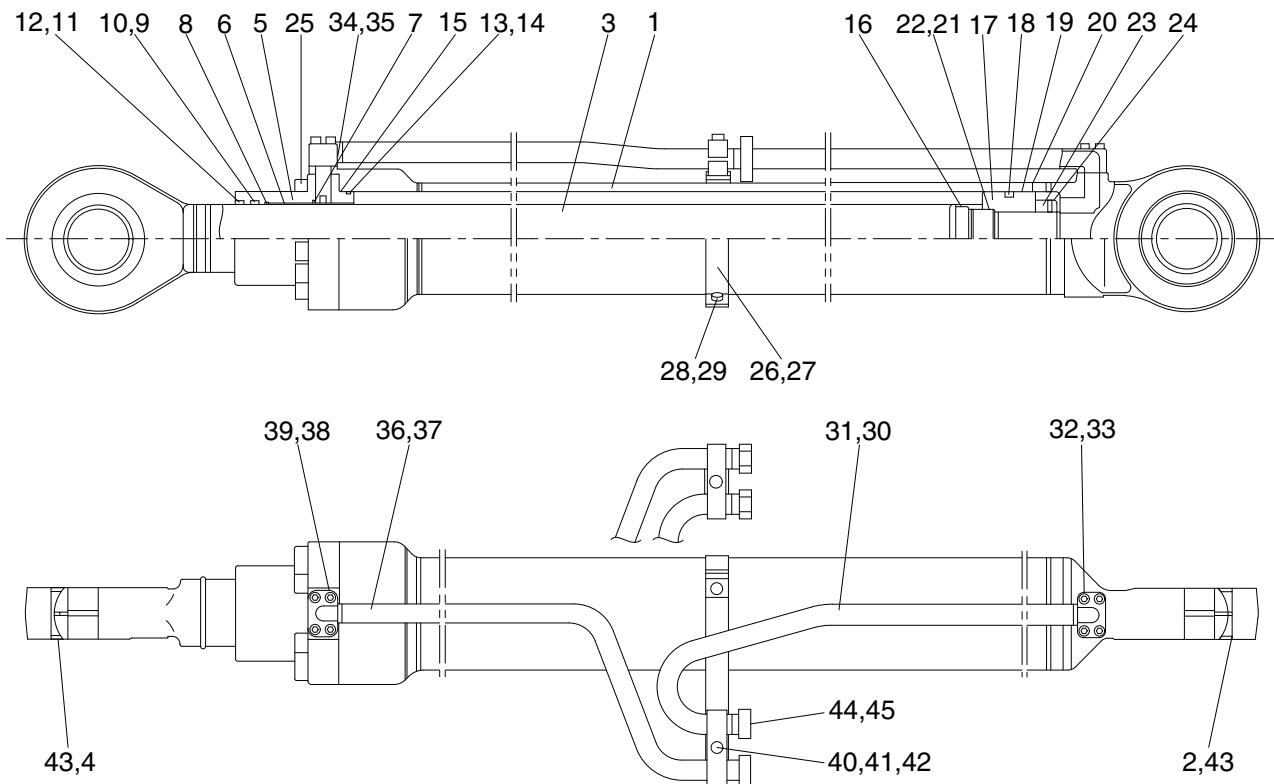

8007A8CY23A

- |    |                   |    |                     |    |                     |
|----|-------------------|----|---------------------|----|---------------------|
| 1  | Tube assembly     | 17 | Piston              | 32 | Hex socket bolt     |
| 2  | Spherical bearing | 18 | Slipper seal        | 33 | Spring washer       |
| 3  | Rod assembly      | 19 | Wear ring           | 34 | Spacer              |
| 4  | Spherical bearing | 20 | Slyd ring           | 35 | O-ring              |
| 5  | Rod cover         | 21 | O-ring              | 36 | Pipe assembly-R(LH) |
| 6  | DD2 bushing       | 22 | Back up ring        | 36 | Pipe assembly-R(RH) |
| 7  | Retaining ring    | 23 | Piston nut          | 37 | O-ring              |
| 8  | Buffer seal       | 24 | Set screw           | 38 | Hex socket bolt     |
| 9  | U-packing         | 25 | Hex socket bolt     | 39 | Spring washer       |
| 10 | Back up ring      | 26 | Pipe band assembly  | 40 | Pipe clamp          |
| 11 | Dust wiper        | 27 | Band pipe           | 41 | Spring washer       |
| 12 | Retaining ring    | 28 | Hex bolt            | 42 | Hex bolt            |
| 13 | O-ring            | 29 | Spring washer       | 43 | Retaining ring      |
| 14 | Back up ring      | 30 | Pipe assembly-H(LH) | 44 | Dust cover          |
| 15 | O-ring            | 30 | Pipe assembly-H(RH) | 45 | Hex bolt            |
| 16 | Cushion ring      | 31 | O-ring              |    |                     |

## 2) TOOLS AND TIGHTENING TORQUE

### (1) Tools

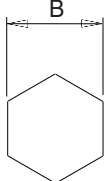
Allen wrench	12	
	14	
	18	
	24	
	27	
(-) Driver	Small and large sizes	
Torque wrench	Capable of tightening with the specified torques	

### (2) Tightening torque

Part name		Item	Size	Torque	
				kgf · m	lbf · ft
Piston	Bucket cylinder	17	-	100±10	723±72
	Boom cylinder	17	-	100±10	723±72
	Arm cylinder	17	-	100±10	723±72
Piston lock nut	Bucket cylinder	23	-	190±19	1374±137
	Boom cylinder	23	-	190±19	1374±137
	Arm cylinder	23	-	190±19	1374±137
Socket head bolt	Bucket cylinder	25	M27	88±1.0	637±7.2
		34	M14	14.5±0.5	105±3.6
	Boom cylinder	25	M27	88±1.0	637±7.2
		38	M14	14.5±0.5	105±3.6
	Arm cylinder	27	M27	88±1.0	637±7.2
		40	M12	11.4±0.4	82.5±2.9

### 3) DISASSEMBLY

#### (1) Remove cylinder head and piston rod

※ Procedures are based on the bucket cylinder.

① Hold the clevis section of the tube in a vise.

※ Use mouth pieces so as not to damage the machined surface of the cylinder tube. Do not make use of the outside piping as a locking means.

② Pull out rod assembly (2) about 200 mm (7.1 in). Because the rod assembly is rather heavy, finish extending it with air pressure after the oil draining operation.

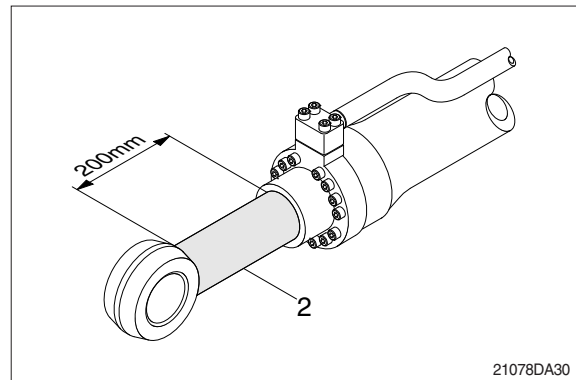

③ Loosen and remove socket bolts (25) of the gland in sequence.

※ Cover the extracted rod assembly (2) with rag to prevent it from being accidentally damaged during operation.

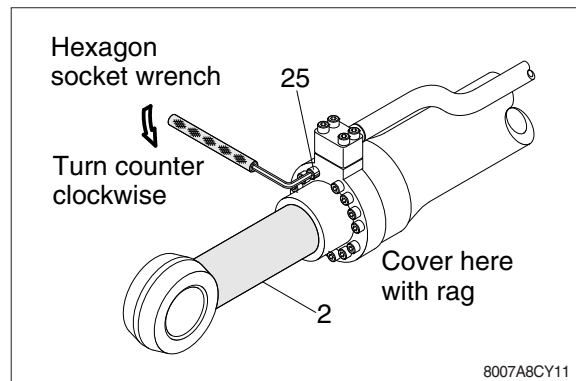

④ Draw out cylinder head and rod assembly together from tube assembly (1).

※ Since the rod assembly is heavy in this case, lift the tip of the rod assembly (2) with a crane or some means and draw it out. However, when rod assembly (2) has been drawn out to approximately two thirds of its length, lift it in its center to draw it completely.

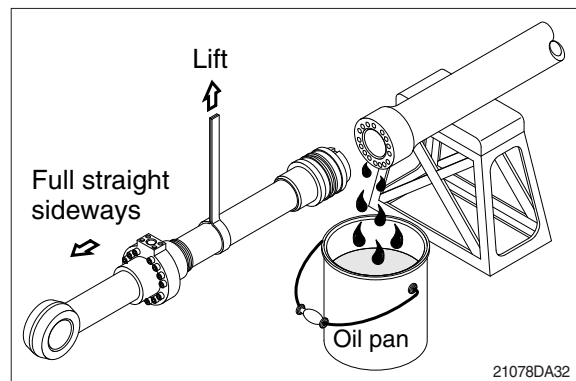

Note that the plated surface of rod assembly (2) is to be lifted. For this reason, do not use a wire sling and others that may damage it, but use a strong cloth belt or a rope.

- ⑤ Place the removed rod assembly on a wooden V-block that is set level.
- ※ Cover a V-block with soft rag.

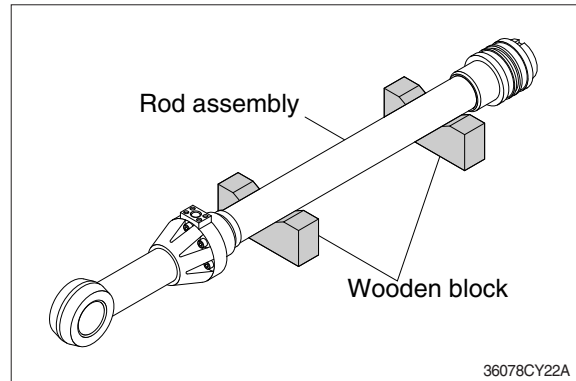

**(2) Remove piston and cylinder head**

- ① Remove lock nut (23).
- ※ Since lock nut (23) and set screw (24) is tightened to a high torque, use a hydraulic and power wrench that utilizes a hydraulic cylinder, to remove the lock nut (23) and set screw (24).
- ② Remove piston assembly (17), back up ring (22), and O-ring (21).

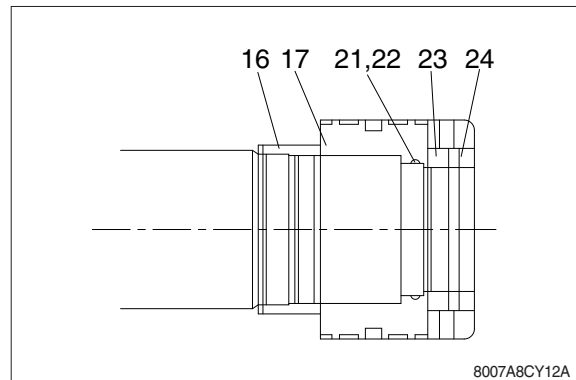

- ③ Remove the cylinder head assembly from rod assembly (2).
  - ※ If it is too heavy to move, move it by striking the flanged part of cylinder head with a plastic hammer.
  - ※ Pull it straight with cylinder head assembly lifted with a crane.
- Exercise care so as not to damage the lip of rod bushing (6) and packing (7, 8, 9, 10,11,12) by the threads of rod assembly (2).

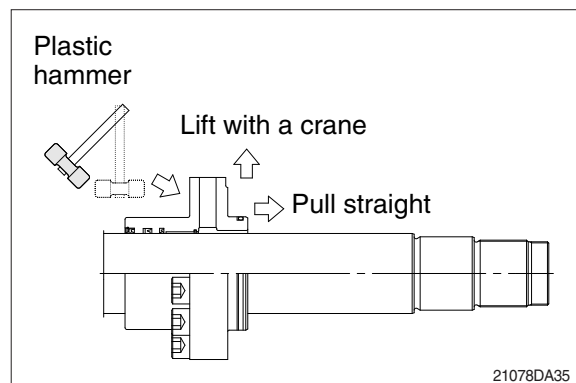

### (3) Disassemble the piston assembly

- ① Remove wear ring (19).
  - ② Remove dust ring (20) and piston seal (18).
- ※ Exercise care in this operation not to damage the grooves.

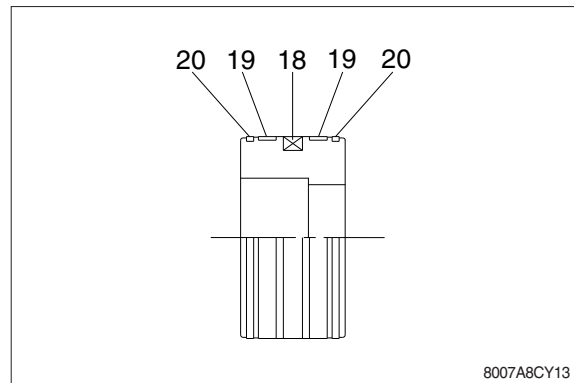

### (4) Disassemble cylinder head assembly

- ① Remove back up ring (14) and O-ring (13,15).
  - ② Remove retaining ring (12), dust wiper (11).
  - ③ Remove back up ring (10), U-packing (9) and buffer seal (8).
- ※ Exercise care in this operation not to damage the grooves.
- ※ Do not remove seal and ring, if does not damaged.

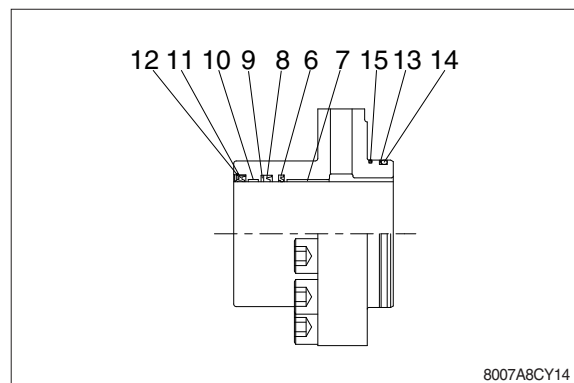

### 3) ASSEMBLY

#### (1) Assemble cylinder head assembly

※ Check for scratches or rough surfaces if found smooth with an oil stone.

- ① Coat the inner face of gland (3) with hydraulic oil.

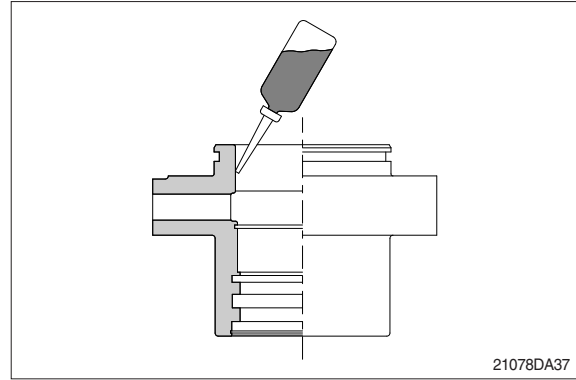

- ② Coat dust wiper (11) with grease and fit dust wiper (11) to the bottom of the hole of dust seal.

At this time, press a pad metal to the metal ring of dust seal.

- ③ Fit retaining ring (12) to the stop face.

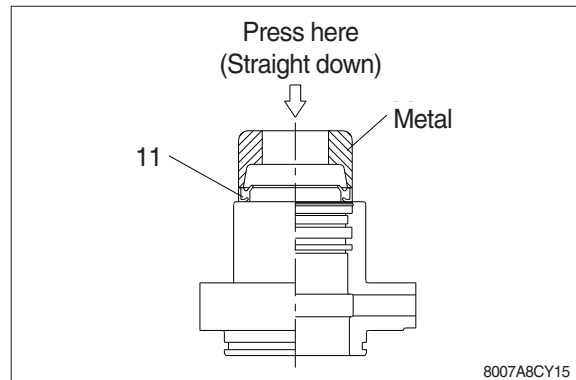

- ④ Fit back up ring (10), U-packing (9) and buffer seal (8) to corresponding grooves, in that order.

※ Coat each packing with hydraulic oil before fitting it.

※ Insert the backup ring until one side of it is inserted into groove.

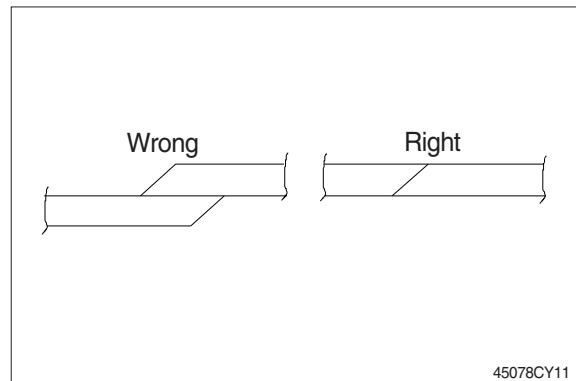

※ U-packing (9) has its own fitting direction. Therefore, confirm it before fitting them.

※ Fitting U-packing (9) upside down may damage its lip. Therefore check the correct direction that is shown in fig.

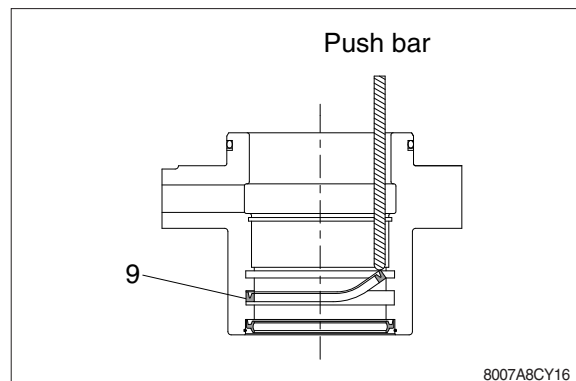

- ⑤ Fit back up ring (14) to gland (3).
- ※ Put the backup ring in the warm water of 30~50°C.
- ⑥ Fit O-ring (13, 15) to gland (3).

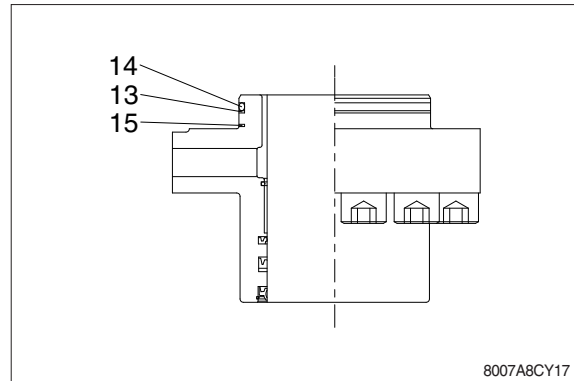

## (2) Assemble piston assembly

- ※ Check for scratches or rough surfaces. If found smooth with an oil stone.
- ① Coat the outer face of piston (17) with hydraulic oil.

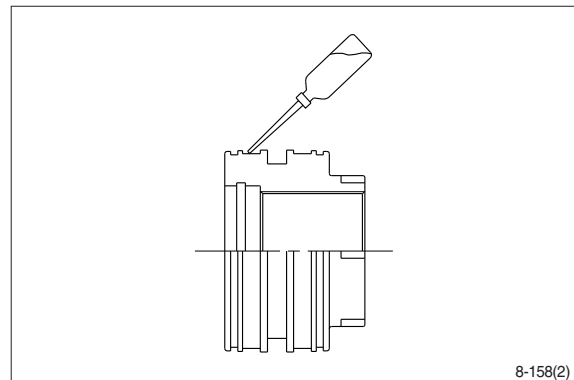

- ② Fit piston seal (18) to piston.
- ※ Put the piston seal in the warm water of 60~100°C for more than 5 minutes.
- ※ After assembling the piston seal, press its outer diameter to fit in.

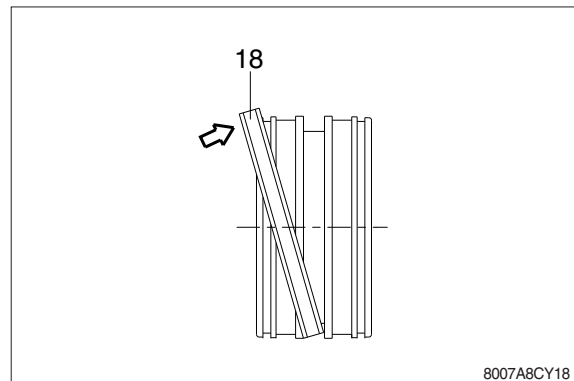

- ③ Fit wear ring (19) and piston ring (20) to piston (17).

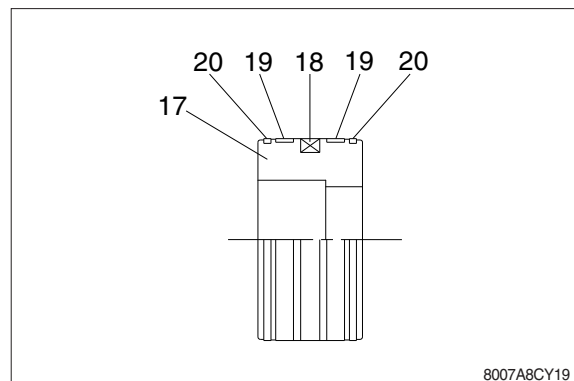

**(3) Install piston and cylinder head**

- ① Fix the rod assembly to the work bench.
- ② Apply hydraulic oil to the outer surface of rod assembly (2), the inner surface of piston and cylinder head.
- ③ Insert cylinder head assembly to rod assembly.

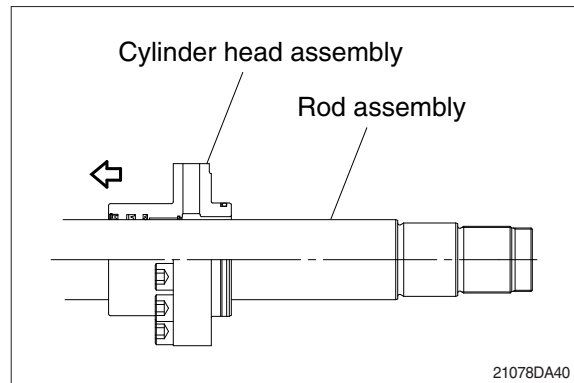

- ④ Insert cushion ring (16) to rod assembly.
- ※ Note that cushion ring (16) has a direction in which it should be fitted.

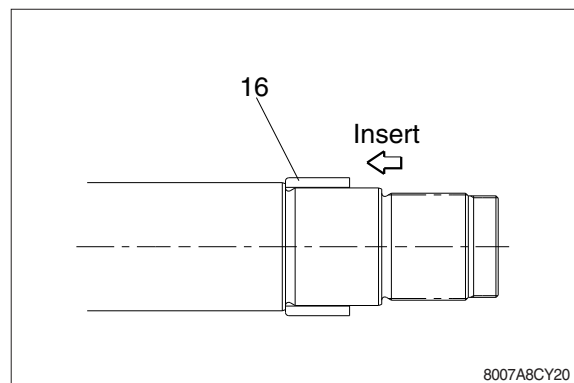

- ⑤ Fit piston assembly to rod assembly.
- Tightening torque :  $100 \pm 10$  kgf · m  
( $723 \pm 72$  lbf · ft)

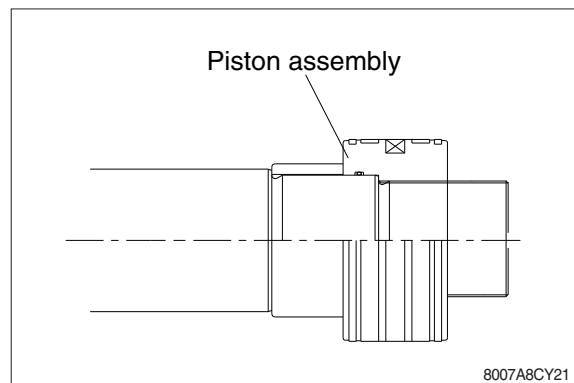

- ⑥ Fit lock nut (23) and tighten the screw (24).
- Tightening torque :

Item		kgf · m	lbf · ft
Bucket	23	$190 \pm 19$	$1374 \pm 137$
Boom	23	$190 \pm 19$	$1374 \pm 137$
Arm	23	$190 \pm 19$	$1374 \pm 137$

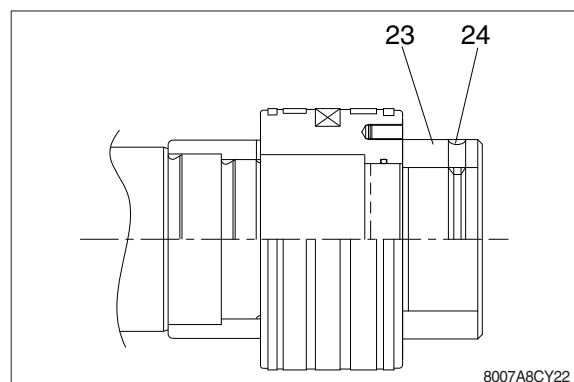



### (3) Overall assemble

- ① Place a V-block on a rigid work bench.  
Mount the tube assembly(1) on it and fix the assembly by passing a bar through the clevis pin hole to lock the assembly.
- ② Insert the rod assembly in to the tube assembly, while lifting and moving the rod assembly with a crane.
  - \* Be careful not to damage piston seal by thread of tube assembly.
- ③ Match the bolt holes in the cylinder head flange to the tapped holes in the tube assembly and tighten socket bolts to a specified torque.
  - \* Refer to the table of tightening torque.

