

## SECTION 7 DISASSEMBLY AND ASSEMBLY

Group 1	Precaution .....	7-1
Group 2	Tightening Torque .....	7-4
Group 3	Pump Device .....	7-7
Group 4	Main Control Valve .....	7-42
Group 5	Swing Device .....	7-66
Group 6	Travel Device .....	7-87
Group 7	RCV Lever .....	7-112
Group 8	Turning Joint .....	7-126
Group 9	Boom, Arm and Bucket Cylinder .....	7-131
Group 10	Undercarriage .....	7-150
Group 11	Work Equipment .....	7-162

# SECTION 7 DISASSEMBLY AND ASSEMBLY

## GROUP 1 PRECAUTIONS

### 1. REMOVAL WORK

- 1) Lower the work equipment completely to the ground.  
If the coolant contains antifreeze, dispose of it correctly.
- 2) After disconnecting hoses or tubes, cover them or fit blind plugs to prevent dirt or dust from entering.
- 3) When draining oil, prepare a container of adequate size to catch the oil.
- 4) Confirm the match marks showing the installation position, and make match marks in the necessary places before removal to prevent any mistake when assembling.
- 5) To prevent any excessive force from being applied to the wiring, always hold the connectors when disconnecting the connectors.
- 6) Fit wires and hoses with tags to show their installation position to prevent any mistake when installing.
- 7) Check the number and thickness of the shims, and keep in a safe place.
- 8) When raising components, be sure to use lifting equipment of ample strength.
- 9) When using forcing screws to remove any components, tighten the forcing screws alternately.
- 10) Before removing any unit, clean the surrounding area and fit a cover to prevent any dust or dirt from entering after removal.
- 11) When removing hydraulic equipment, first release the remaining pressure inside the hydraulic tank and the hydraulic piping.
- 12) If the part is not under hydraulic pressure, the following corks can be used.

Nominal number	Dimensions		
	D	d	L
06	6	5	8
08	8	6.5	11
10	10	8.5	12
12	12	10	15
14	14	11.5	18
16	16	13.5	20
18	18	15	22
20	20	17	25
22	22	18.5	28
24	24	20	30
27	27	22.5	34

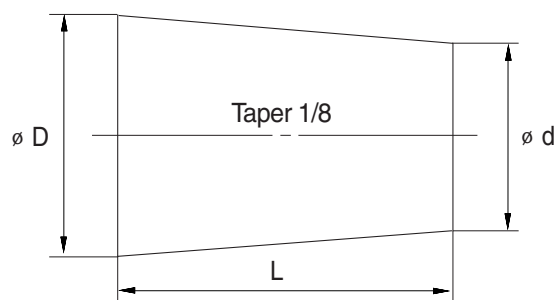

## 2. INSTALL WORK

- 1) Tighten all bolts and nuts(Sleeve nuts) to the specified torque.
- 2) Install the hoses without twisting or interference.
- 3) Replace all gaskets, O-rings, cotter pins, and lock plates with new parts.
- 4) Bend the cotter pin or lock plate securely.
- 5) When coating with adhesive, clean the part and remove all oil and grease, then coat the threaded portion with 2-3 drops of adhesive.
- 6) When coating with gasket sealant, clean the surface and remove all oil and grease, check that there is no dirt or damage, then coat uniformly with gasket sealant.
- 7) Clean all parts, and correct any damage, dents, burrs, or rust.
- 8) Coat rotating parts and sliding parts with engine oil.
- 9) When press fitting parts, coat the surface with antifriction compound(LM-P).
- 10) After installing snap rings, check that the snap ring is fitted securely in the ring groove(Check that the snap ring moves in the direction of rotation).
- 11) When connecting wiring connectors, clean the connector to remove all oil, dirt, or water, then connect securely.
- 12) When using eyebolts, check that there is no deformation or deterioration, and screw them in fully.
- 13) When tightening split flanges, tighten uniformly in turn to prevent excessive tightening on one side.
- 14) When operating the hydraulic cylinders for the first time after repairing and reassembling the hydraulic cylinders, pumps, or other hydraulic equipment or piping, always bleed the air from the hydraulic cylinders as follows:
  - (1) Start the engine and run at low idling.
  - (2) Operate the control lever and actuate the hydraulic cylinder 4-5 times, stopping 100mm before the end of the stroke.
  - (3) Next, operate the piston rod to the end of its stroke to relieve the circuit. (The air bleed valve is actuated to bleed the air.)
  - (4) After completing this operation, raise the engine speed to the normal operating condition.
    - ※ If the hydraulic cylinder has been replaced, carry out this procedure before assembling the rod to the work equipment.
    - ※ Carry out the same operation on machines that have been in storage for a long time after completion of repairs.

### **3. COMPLETING WORK**

- 1) If the coolant has been drained, tighten the drain valve, and add water to the specified level. Run the engine to circulate the water through the system. Then check the water level again.
- 2) If the hydraulic equipment has been removed and installed again, add engine oil to the specified level. Run the engine to circulate the oil through the system. Then check the oil level again.
- 3) If the piping or hydraulic equipment, such as hydraulic cylinders, pumps, or motors, have been removed for repair, always bleed the air from the system after reassembling the parts.
- 4) Add the specified amount of grease(Molybdenum disulphied grease) to the work equipment related parts.



## GROUP 2 TIGHTENING TORQUE

### 1. MAJOR COMPONENTS

No.	Descriptions	Bolt size	Torque		
			kgf · m	lbf · ft	
1	Engine	Engine mounting bolt (engine-bracket)	M10 × 1.5	7 ± 1.5	50.6 ± 10.9
2		Engine mounting bolt (bracket-frame)	M16 × 2.0	30 ± 4.5	217 ± 32.5
3		Radiator mounting bolt, nut	M12 × 1.75	12.8 ± 3.0	92.6 ± 21.7
4		Coupling mounting bolt	M14 × 2.0	14 ± 1.0	101 ± 7.2
5	Hydraulic system	Main pump mounting bolt	M12 × 1.75	12 ± 1.0	86.8 ± 7.2
6		Main control valve mounting bolt	M 8 × 1.25	3.4 ± 0.7	24.6 ± 5.0
7		Fuel tank mounting bolt	M16 × 2.0	29.7 ± 4.5	215 ± 32.5
8		Hydraulic oil tank mounting bolt	M16 × 2.0	29.7 ± 4.5	215 ± 32.5
9		Turning joint mounting bolt, nut	M12 × 1.75	12.3 ± 1.3	89 ± 9.4
10	Power train system	Swing motor mounting bolt	M16 × 2.0	29.7 ± 4.5	215 ± 32.5
11		Swing bearing upper mounting bolt	M16 × 2.0	29.7 ± 3.0	215 ± 21.7
12		Swing bearing lower mounting bolt	M16 × 2.0	29.7 ± 3.0	215 ± 21.7
13		Travel motor mounting bolt	M16 × 2.0	23 ± 2.5	166 ± 18.1
14	Under carriage	Sprocket mounting bolt	M16 × 2.0	29.7 ± 3.0	215 ± 21.7
15		Carrier roller mounting bolt, nut	M16 × 2.0	29.7 ± 3.0	215 ± 21.7
16		Track roller mounting bolt	M14 × 2.0	19.6 ± 2.0	142 ± 14.5
17		Track tension cylinder mounting bolt	M16 × 2.0	29.7 ± 3.0	215 ± 21.7
18		Track shoe mounting bolt, nut	M14 × 1.5	25.5 ± 2.5	184 ± 18.1
19	Others	Counter weight mounting bolt	M27 × 3.0	140 ± 15	1013 ± 108
20		Cab mounting bolt, nut	M12 × 1.75	12.2 ± 1.3	88.2 ± 9.4
21		Operator's seat mounting bolt	M 8 × 1.25	1.17 ± 0.5	8.5 ± 3.6

## 2. TORQUE CHART

Use following table for unspecified torque.

### 1) BOLT AND NUT

#### (1) Coarse thread

Bolt size	8T		10T	
	kg · m	lb · ft	kg · m	lb · ft
M 6 × 1.0	0.85 ~ 1.25	6.15 ~ 9.04	1.14 ~ 1.74	8.2 ~ 12.6
M 8 × 1.25	2.0 ~ 3.0	14.5 ~ 21.7	2.7 ~ 4.1	19.5 ~ 29.7
M10 × 1.5	4.0 ~ 6.0	28.9 ~ 43.4	5.5 ~ 8.3	39.8 ~ 60
M12 × 1.75	7.4 ~ 11.2	53.5 ~ 81.0	9.8 ~ 15.8	70.9 ~ 114
M14 × 2.0	12.2 ~ 16.6	88.2 ~ 120	16.7 ~ 22.5	121 ~ 163
M16 × 2.0	18.6 ~ 25.2	135 ~ 182	25.2 ~ 34.2	182 ~ 247
M18 × 2.5	25.8 ~ 35.0	187 ~ 253	35.1 ~ 47.5	254 ~ 344
M20 × 2.5	36.2 ~ 49.0	262 ~ 354	49.2 ~ 66.6	356 ~ 482
M22 × 2.5	48.3 ~ 63.3	349 ~ 458	65.8 ~ 98.0	476 ~ 709
M24 × 3.0	62.5 ~ 84.5	452 ~ 611	85.0 ~ 115	615 ~ 832
M30 × 3.0	124 ~ 168	898 ~ 1214	169 ~ 229	1223 ~ 1656
M36 × 4.0	174 ~ 236	1261 ~ 1704	250 ~ 310	1808 ~ 2242

#### (2) Fine thread

Bolt size	8T		10T	
	kg · m	lb · ft	kg · m	lb · ft
M 8 × 1.0	2.2 ~ 3.4	15.9 ~ 24.6	3.0 ~ 4.4	21.7 ~ 31.8
M10 × 1.2	4.5 ~ 6.7	32.5 ~ 48.5	5.9 ~ 8.9	42.7 ~ 64.4
M12 × 1.25	7.8 ~ 11.6	56.4 ~ 83.9	10.6 ~ 16.0	76.7 ~ 116
M14 × 1.5	13.3 ~ 18.1	96.2 ~ 131	17.9 ~ 24.1	130 ~ 174
M16 × 1.5	19.9 ~ 26.9	144 ~ 195	26.6 ~ 36.0	192 ~ 260
M18 × 1.5	28.6 ~ 43.6	207 ~ 315	38.4 ~ 52.0	278 ~ 376
M20 × 1.5	40.0 ~ 54.0	289 ~ 391	53.4 ~ 72.2	386 ~ 522
M22 × 1.5	52.7 ~ 71.3	381 ~ 516	70.7 ~ 95.7	511 ~ 692
M24 × 2.0	67.9 ~ 91.9	491 ~ 665	90.9 ~ 123	658 ~ 890
M30 × 2.0	137 ~ 185	990 ~ 1339	182 ~ 248	1314 ~ 1796
M36 × 3.0	192 ~ 260	1390 ~ 1880	262 ~ 354	1894 ~ 2562

**2) PIPE AND HOSE (FLARE type)**

Thread size (PF)	Width across flat (mm)	kgf · m	lbf · ft
1/4"	19	4	28.9
3/8"	22	5	36.2
1/2"	27	9.5	68.7
3/4"	36	18	130
1"	41	21	152
1-1/4"	50	35	253

**3) PIPE AND HOSE (ORFS type)**

Thread size (UNF)	Width across flat (mm)	kgf · m	lbf · ft
9/16-18	19	4	28.9
11/16-16	22	5	36.2
13/16-16	27	9.5	68.7
1-3/16-12	36	18	130
1-7/16-12	41	21	152
1-11/16-12	50	35	253

**4) FITTING**

Thread size	Width across flat (mm)	kgf · m	lbf · ft
1/4"	19	4	28.9
3/8"	22	5	36.2
1/2"	27	9.5	68.7
3/4"	36	18	130
1"	41	21	152
1-1/4"	50	35	253

## GROUP 3 PUMP DEVICE

### 1. REMOVAL AND INSTALL

#### 1) REMOVAL

- (1) Lower the work equipment to the ground and stop the engine.
- (2) Operate the control levers and pedals several times to release the remaining pressure in the hydraulic piping
- (3) Loosen the breather slowly to release the pressure inside the hydraulic tank.

**▲ Escaping fluid under pressure can penetrate the skin causing serious injury.**

- (4) Loosen the drain plug under the hydraulic tank and drain the oil from the hydraulic tank.

- Hydraulic tank quantity : 71 l  
(18.8 U.S.gal)

- (5) Disconnect hydraulic hoses (11, 12, 13, 17, 18).

- (6) Remove bolts (29) and disconnect pump suction pipe (1, 2).

※ When pump suction pipe is disconnected, the oil inside the piping will flow out, so catch it in oil pan.

- (7) Sling the pump assembly and remove the pump mounting bolts.

- Weight : 60 kg (70 lb)

※ Pull out the pump assembly from housing. When removing the pump assembly, check that all the hoses have been disconnected.

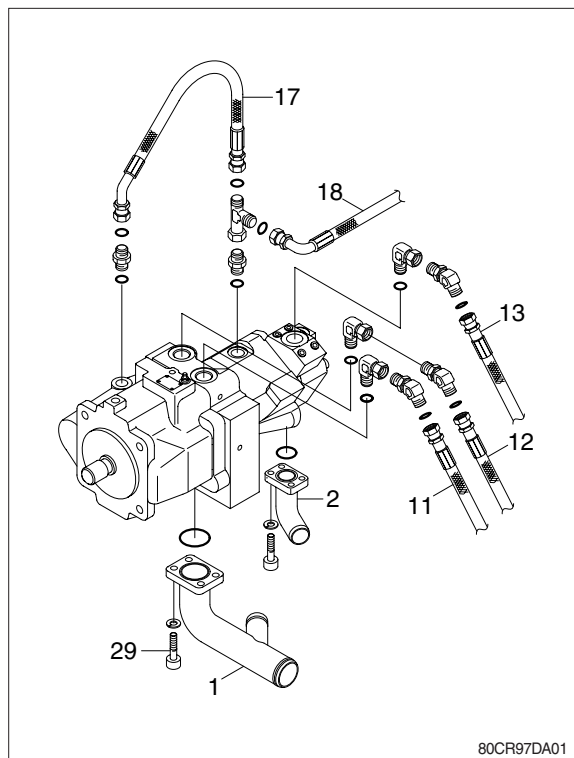

## 2) INSTALL

- (1) Carry out installation in the reverse order to removal.
- (2) Remove the suction strainer and clean it.
- (3) Replace return filter with new one.
- (4) Remove breather and clean it.
- (5) After adding oil to the hydraulic tank to the specified level.
- (6) Bleed the air from the hydraulic pump.
  - ① Loosen the air vent plug.
  - ② Start the engine, run at low idling, and check oil come out from plug.
  - ③ Tighten plug.
- (7) Start the engine, run at low idling (3~5 minutes) to circulate the oil through the system.
- (8) Confirm the hydraulic oil level and check the hydraulic oil leak or not.

## 2. MAIN PUMP

### 1) STRUCTURE (1/3)

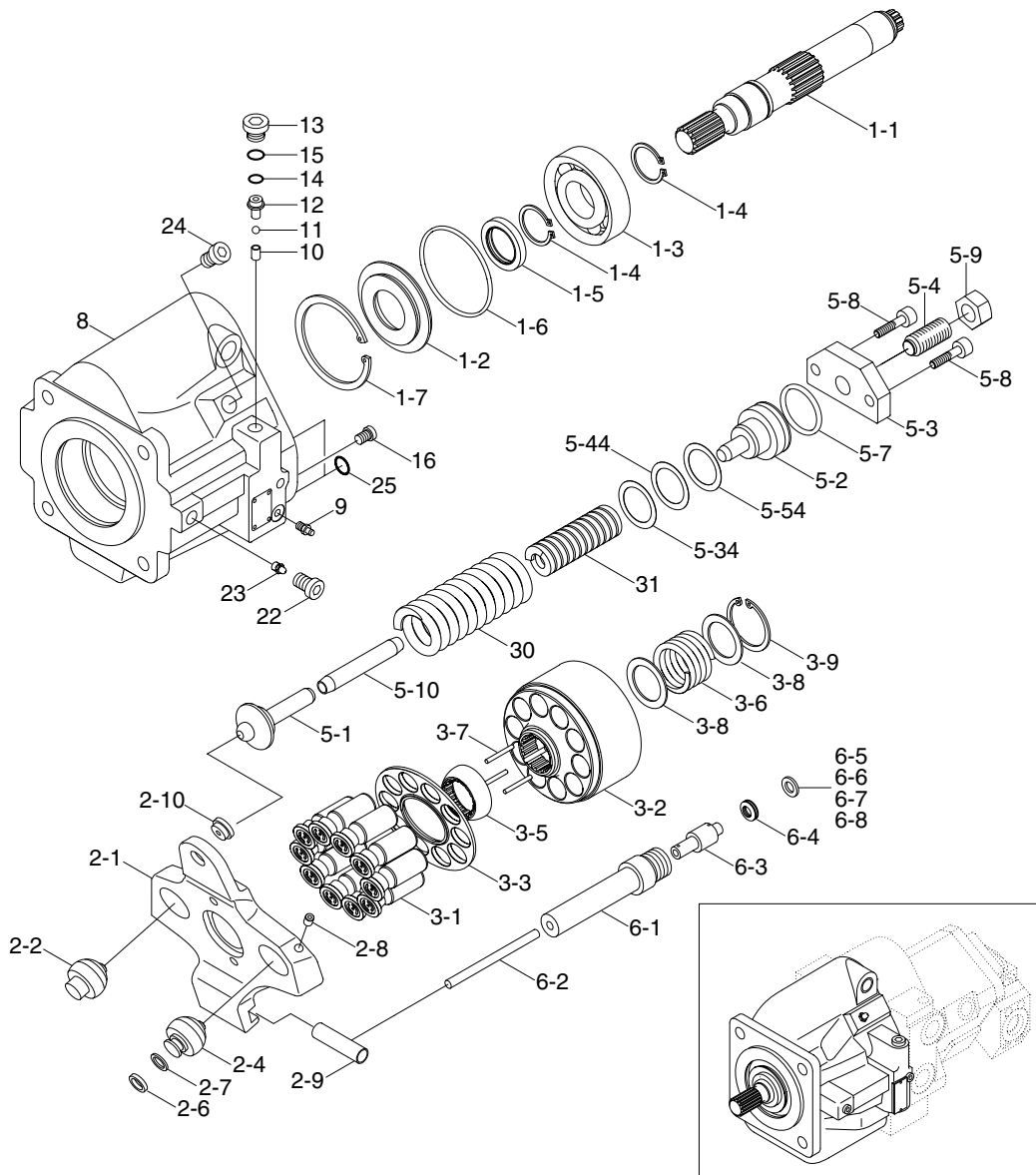

80CR97MP100

1	Shaft assy	2-10	Bushing	5-8	Bolt	8	Housing
1-1	Shaft	3	Rotary group	5-9	Nut	9	Air vent valve
1-2	Seal retainer	3-1	Piston	5-10	Guide	10	Bushing
1-3	Bearing	3-2	Cylinder block	5-34	Shim (0.3T)	11	Steel ball
1-4	Retaining ring	3-3	Retainer	5-44	Shim (0.5T)	12	Plug
1-5	Oil seal	3-5	Guide	5-54	Shim (1.0T)	13	Plug
1-6	O-ring	3-6	Spring	6	Control piston assy	14	Packing
1-7	Retaining ring	3-7	Parallel pin	6-1	Cylinder	15	Shim
2	Swash plate assy	3-8	Spring seat	6-2	Piston	16	Plug
2-1	Swash plate	3-9	Retaining ring	6-3	Piston	22	Plug assy
2-2	Guide	5	Spring seat assy	6-4	Spring	23	Orifice
2-4	Guide	5-1	Spring seat	6-5	Spacer	24	Plug
2-6	O-ring	5-2	Spring seat	6-6	Spacer	25	Square ring
2-7	Back up ring	5-3	Cover	6-7	Spacer	30	Spring
2-8	D/Break off pin	5-4	Adjust screw	6-8	Spacer	31	Spring
2-9	Pin	5-7	O-ring				

## STRUCTURE (2/3)

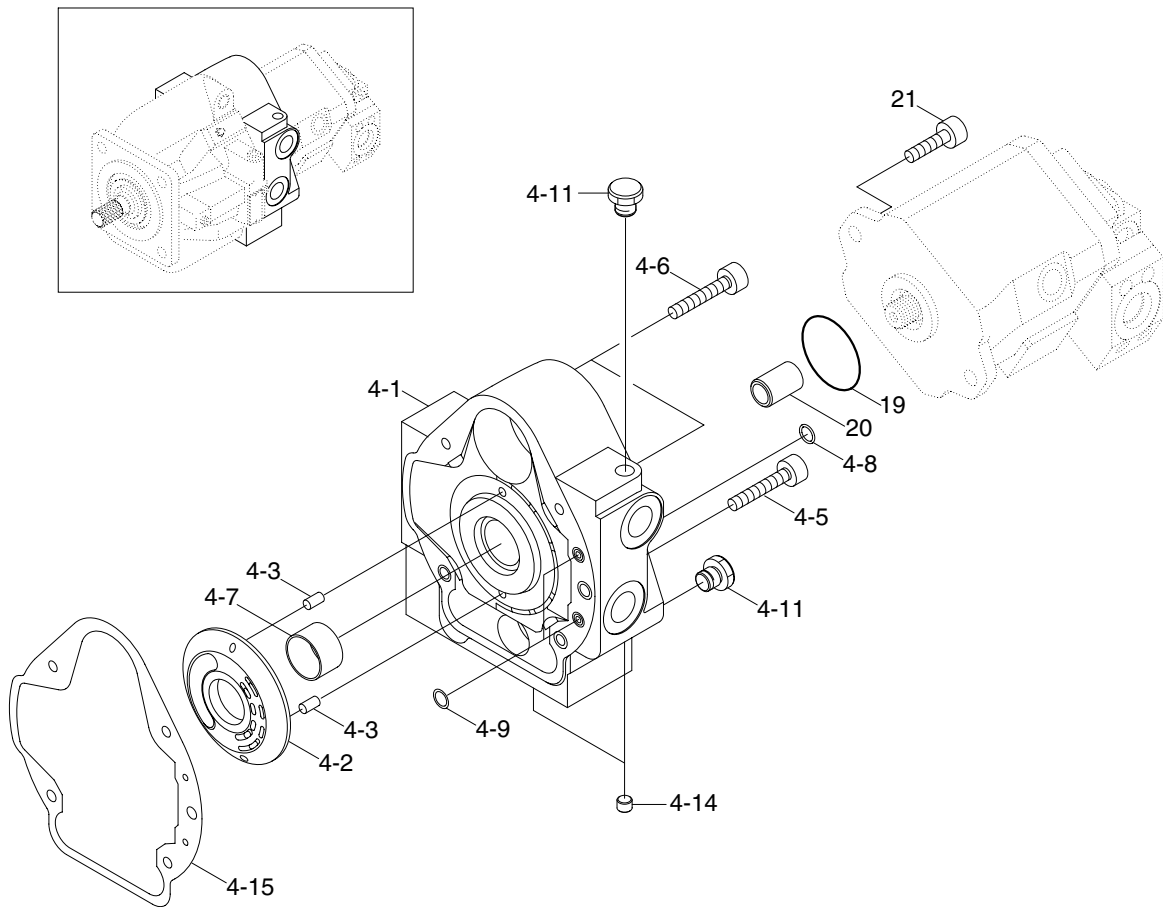

80CR97MP101

4	Port plate assy	4-6	Screw	4-14	Plug
4-1	Cover	4-7	Bearing	4-15	Packing
4-2	Control plate	4-8	O-ring	19	O-ring
4-3	Parallel pin	4-9	Square ring	20	Coupling
4-5	Screw	4-11	Plug	21	Screw

### STRUCTURE (3/3)

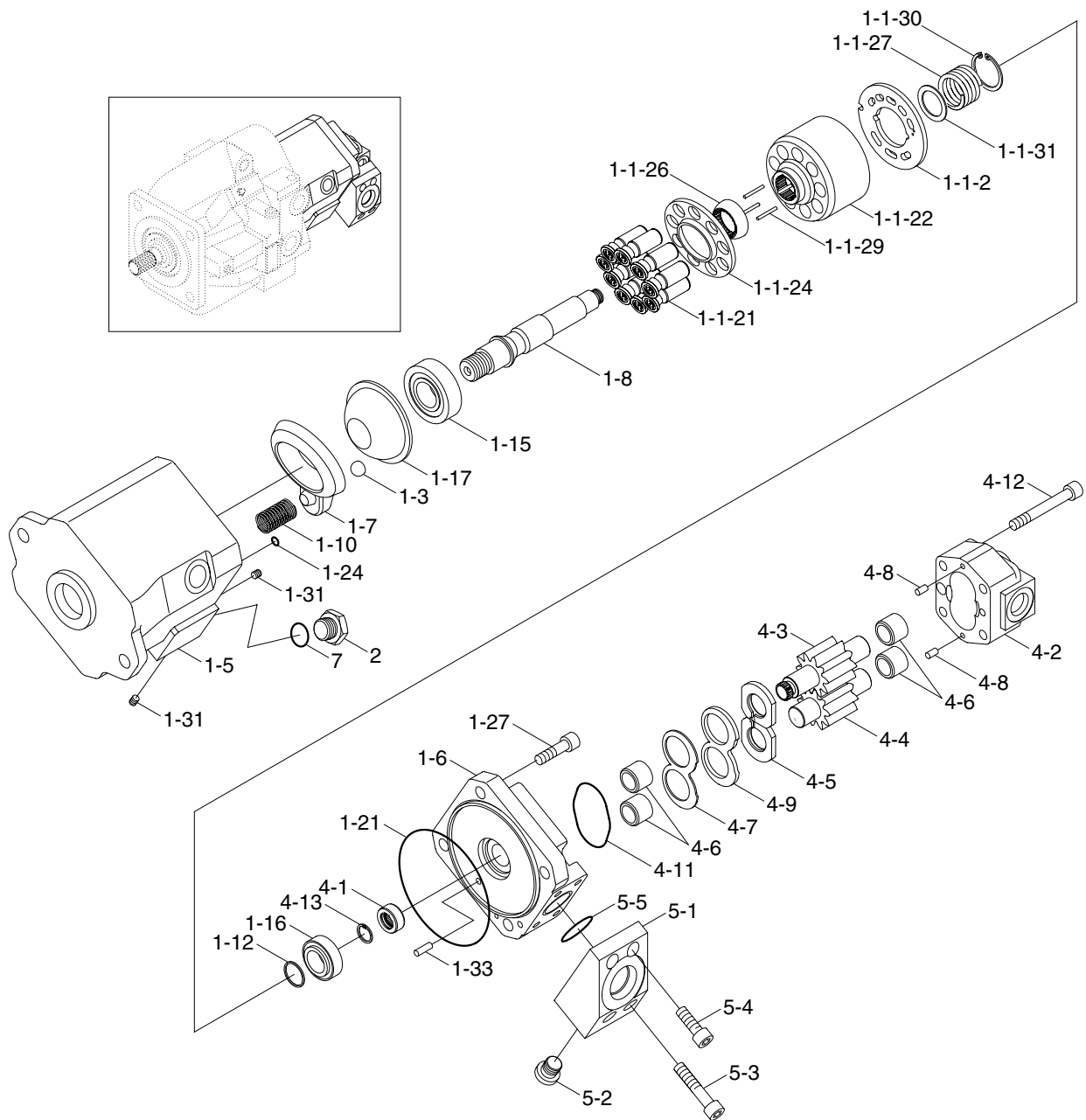

80CR97MP102

1	Piston pump	1-3	Ball stop	1-27	Bolt	4-8	Parallel pin
1-1	Rotary group	1-5	Pump housing	1-31	Plug	4-9	Square ring
1-1-1	Rotary group	1-6	Port plate	1-33	Parallel pin	4-11	O-ring
1-1-21	Piston complete	1-7	Swash plate	2	Plug	4-12	Bolt
1-1-22	Cylinder block	1-8	Drive shaft	4	Gear pump	4-13	Retaining ring
1-1-24	Retaining plate	1-10	Spring	4-1	Coupling	5	Flange assy
1-1-26	Retaining ball	1-12	Adjustment shim	4-2	Housing	5-1	Flange
1-1-27	Spring	1-15	Bearing	4-3	Drive gear	5-2	Plug
1-1-29	Pin	1-16	Bearing	4-4	Idle gear	5-3	Screw
1-1-30	V-ring	1-17	Cradle shell	4-5	Thrust plate	5-4	Screw
1-1-31	Backup plate	1-21	O-ring	4-6	Metal	5-5	O-ring
1-1-2	Control plate	1-24	Square ring	4-7	Back up ring	7	O-ring



### 3. DISASSEMBLY AND ASSEMBLY

#### 1) NECESSARY TOOLS AND JIGS

The following tools and jigs are necessary to disassemble and assemble the pump.

##### (1) Tools

Name	Size (nominal)	Quantity
Hexagon socket screw key	6, 8, 10, 12	One each
Spanner	27, 32	One each
Screw driver for slotted-head screws	Medium size	2
Plastic hammer	Medium size	1
Pliers for retaining ring	For bore use (retaining ring for 80)	1
Grease	-	Small amount
Adhesive	Three bond #1305	Small amount

##### (2) Jigs

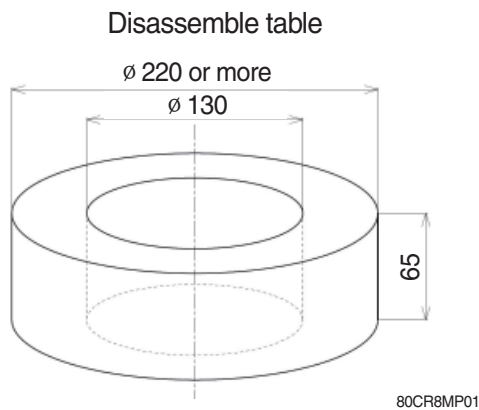

Guide bolt for disassemble and assemble port plate

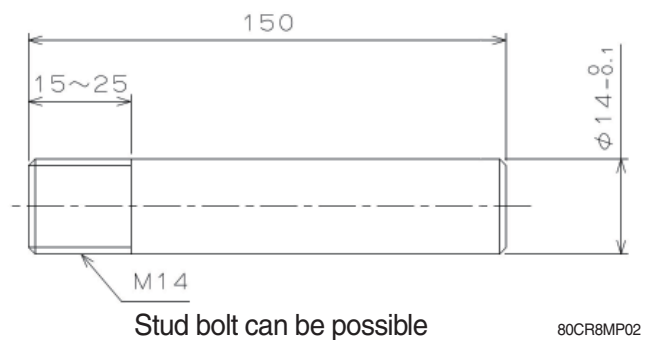

- ※ This is a plate to stand the pump facing downward.  
A square block may be used if the shaft does not contact.

## 2) CAUTIONS DURING DISASSEMBLING AND ASSEMBLING

### (1) Cautions for disassembling

- ① Do not loosen adjusting screw unless absolutely necessary.
- ② Take utmost care during disassembly not to knock or drop each part.
- ③ Special attention is necessary for disassemble port plate, because spring load is very high.

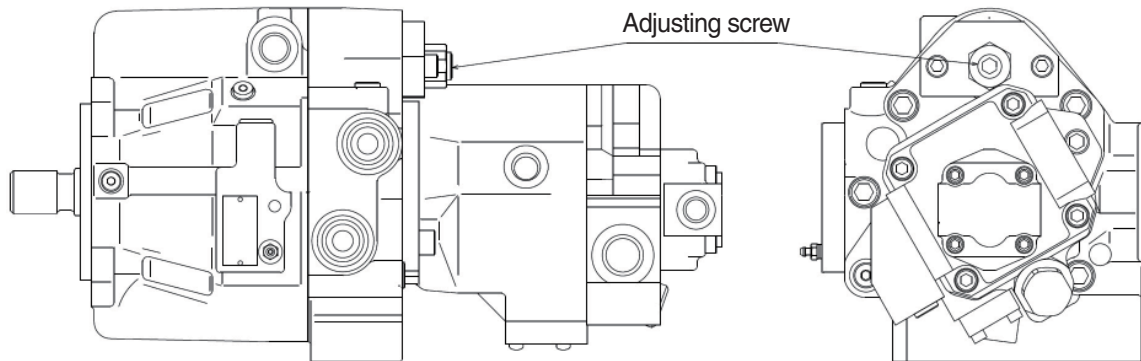

80CR8MP03

### (2) Cautions for assembling

- ① Wash each part thoroughly.
- ② During assembling, take utmost care not to damage the part or allow foreign materials to enter.
- ③ Special attention is necessary for assemble port plate, because spring load is very high.
- ④ As a rule, the O-ring and oil seal should not be reused.
- ⑤ Apply the grease for each sliding surfaces.
- ⑥ In our assembly work, the torque wrench is used to control the torque.  
Be sure to use the torque wrench.

### 3) DISASSEMBLING PROCEDURE (main pump)

#### (1) Disassembling the rear pump.

- ① Remove the hexagon socket head cap screws and plain washers.  
(M12×30, 2 pieces)  
Hexagon socket screw key  
(Hexagon side distance : 10 mm)
- ② Coupling on the port plate side are detached at the same time.

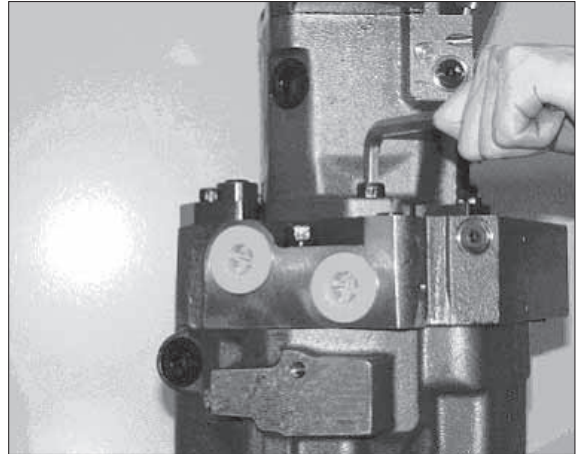

80CR8MP04

#### (2) Remove the port plate.

- ① Remove hexagon socket head cap screws.  
(M14×70, 4 pieces and M14×65, 1 piece)  
Hexagon socket screw key  
(Hexagon side distance : 12 mm)

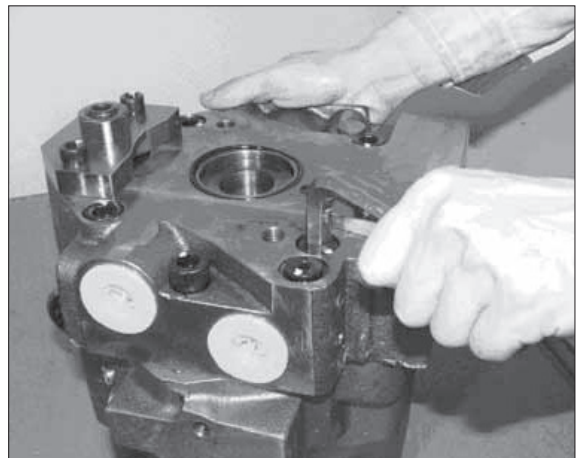

80CR8MP05

#### ② Install the guide bolts to the port plate.

Be careful because control plate and control piston are on the backside of port plate.

When port plate doesn't come off easily, you can use a plastic hammer lightly.

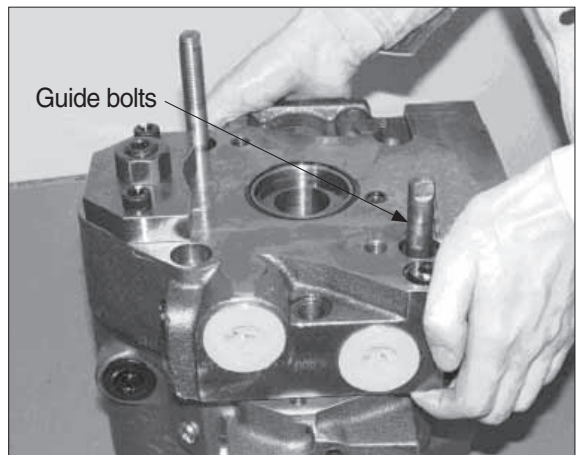

80CR8MP06

- (3) Remove the inside parts.  
Remove the gasket, control springs (inner and outer), guide, and spring seat.

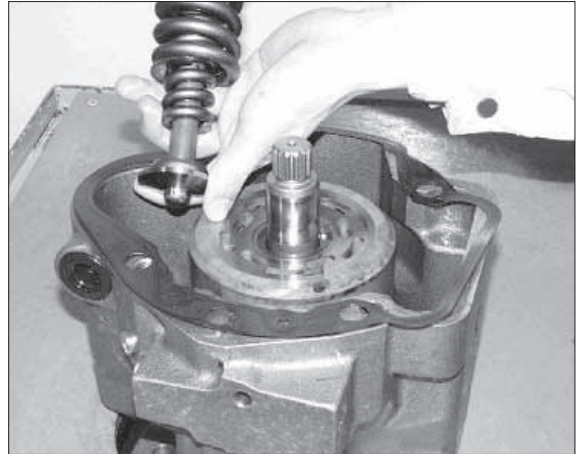

80CR8MP07

- (4) Remove rotary group.  
① Push down sideways the pump.  
② Take out the rotary group with both hands holding retaining plate and piston assembly.

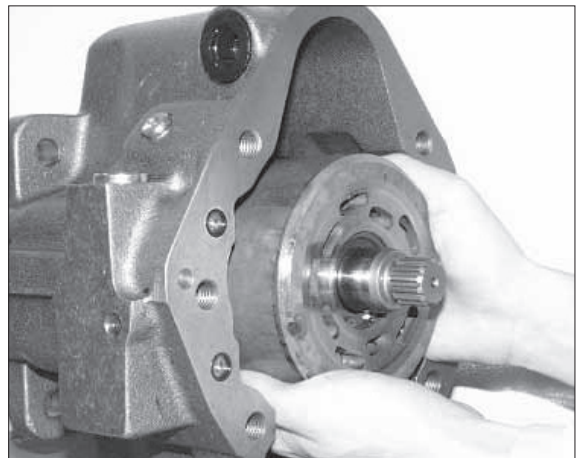

80CR8MP08

- ③ The parallel pins ( $\varnothing 3 \times 30$ , 3 pieces) may remain in the housing, when removing the rotary group. Please take out the parallel pins when they were left in the housing.

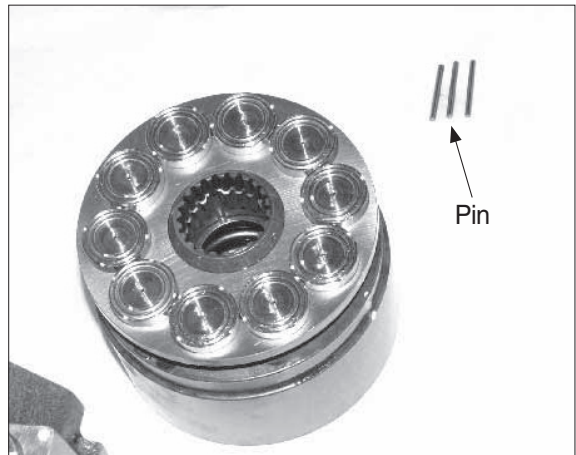

80CR8MP09

(5) Remove the shaft.

- ① Remove the retaining ring.  
(For bore use ; 80)

Pliers for retaining rings  
(For bore use ; retaining ring for 80)

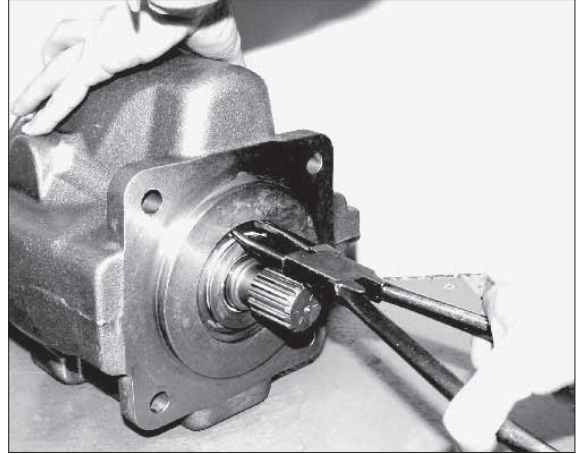

80CR8MP10

- ② Remove the shaft seal case and O-ring behind the seal case.

Screwdrivers for slotted-head screws  
(medium size)

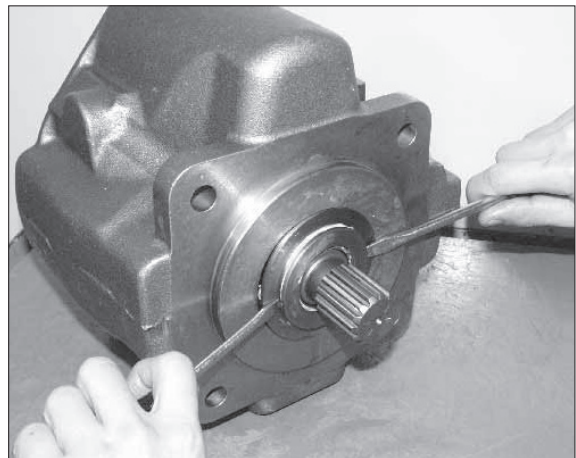

80CR8MP11

- ③ Remove the shaft.

When the shaft doesn't come off easily,  
you can use a plastic hammer and hit a  
shaft end of backside lightly.

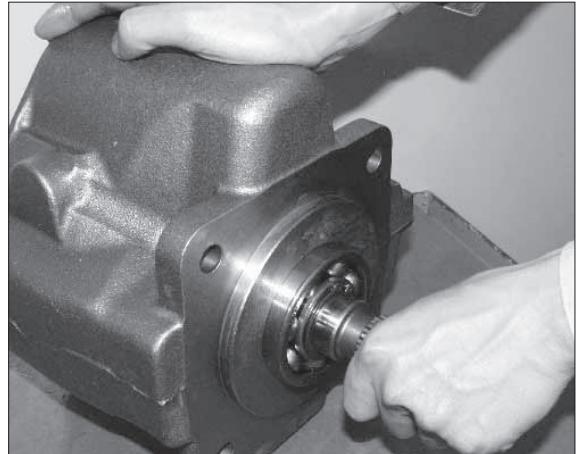

80CR8MP12



(6) Remove the swash plate.

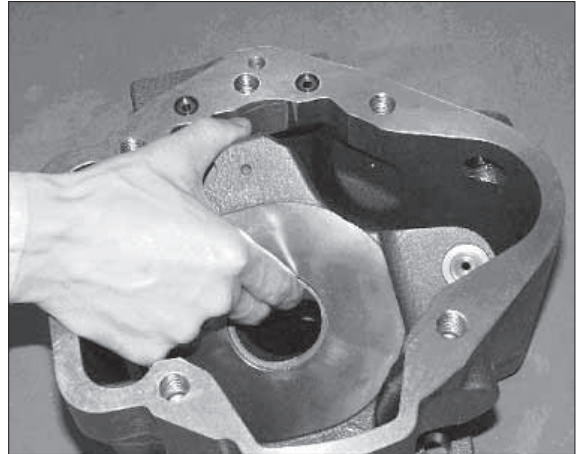

80CR8MP13

(7) Disassemble the ball guide.

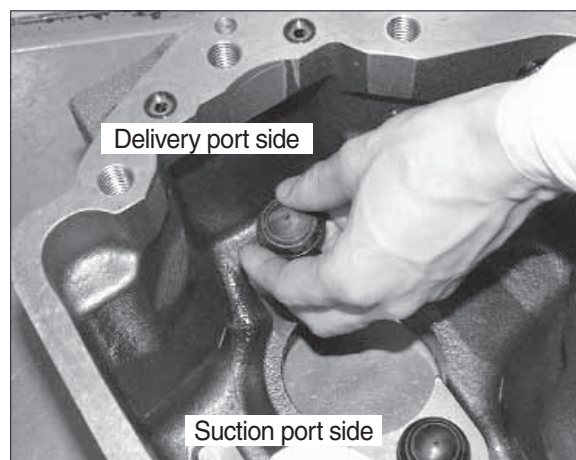

80CR8MP14

(8) Disassemble the port plate.

① Remove the control plate.

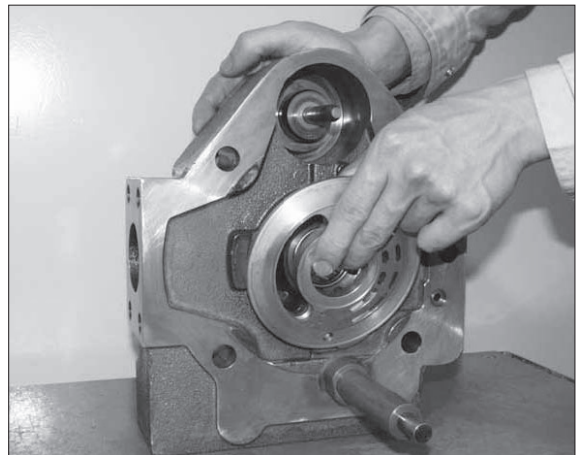

80CR8MP15

- ② Remove the control piston assembly.  
Remove the piston.

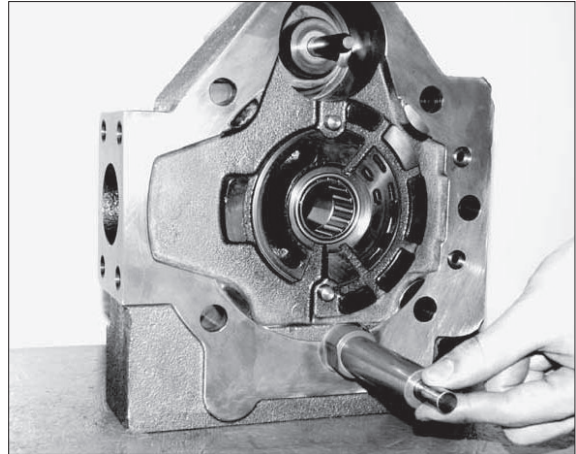

80CR8MP16

- ③ Remove the cylinder.

· Spanner (27 mm)

Be careful because piston and coned disk spring and distance piece are in the port plate.

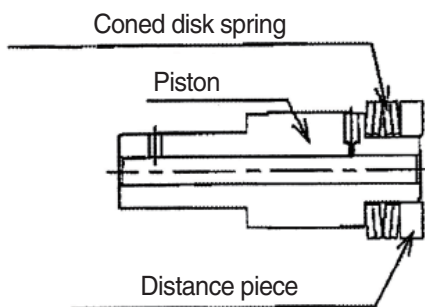

80CR8MP18

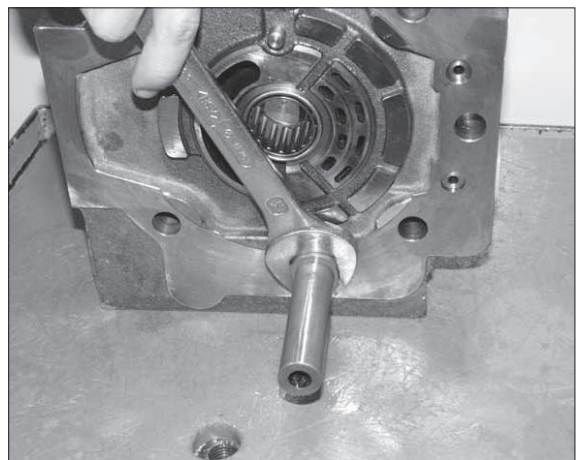

80CR8MP17

- ④ Remove the spring seat assembly.

※ Only when it is necessary  
(The setting changes if the hexagonal nut is loosened.)

Remove the hexagon socket head cap screws.

(M10×30, 2 pieces)

Hexagon socket screw key

(Hexagon side distance : 8 mm)

Only when it is necessary

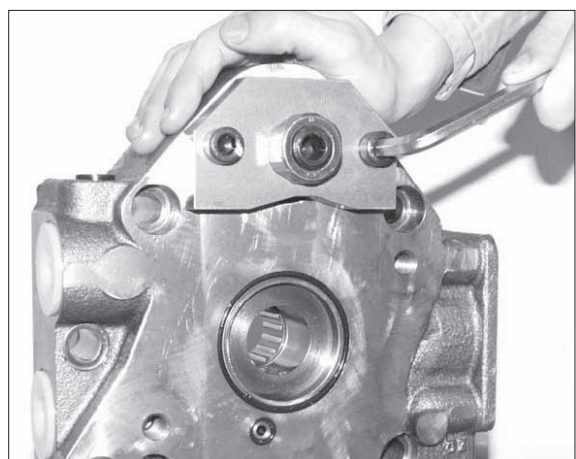

80CR8MP19

⑤ Remove the spring seat.

Be careful because shim might attach to the spring seat.

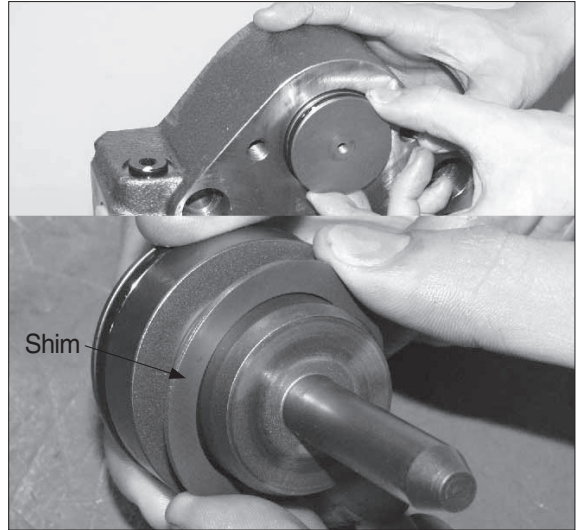

80CR8MP20



#### 4) MAINTENANCE AND SERVICE STANDARD FOR THE MAIN PUMP

Before inspection wash the parts well and dry them completely.

Inspect the principal parts with care and replace them with new parts when any abnormal wear exceeding the allowable limit or damage considered harmful is found.

Replace the seal also when any remarkable deformation and damage are found.

##### (1) Piston assembly and cylinder block

- Check the appearance visually.  
No damage showing abnormal wear (particularly in the side portion) should be found.
- Check the clearance between the piston outside dia and the cylinder block inside dia.  
 $D-d \leq 0.06 \text{ mm}$

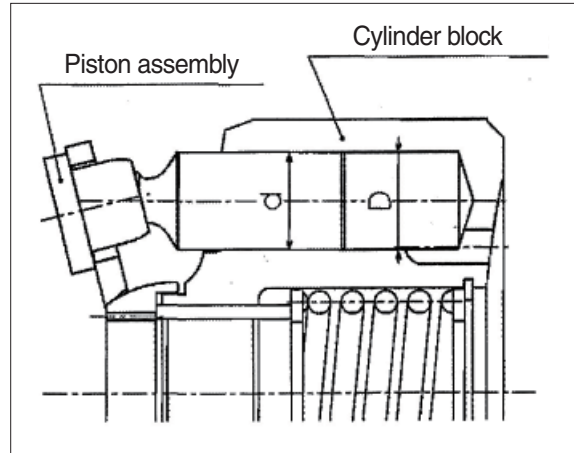

80CR8MP21

##### (2) Piston shoe and piston

- Check the piston shoe.  
 $\varepsilon \leq 0.2 \text{ mm}$

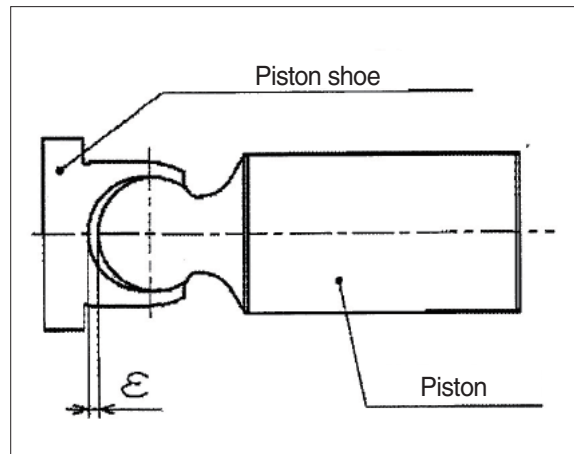

80CR8MP22

##### (3) Shaft

- Check the wear amount of the oil seal mounting section.  
Wear amount  $\leq 0.025 \text{ mm}$

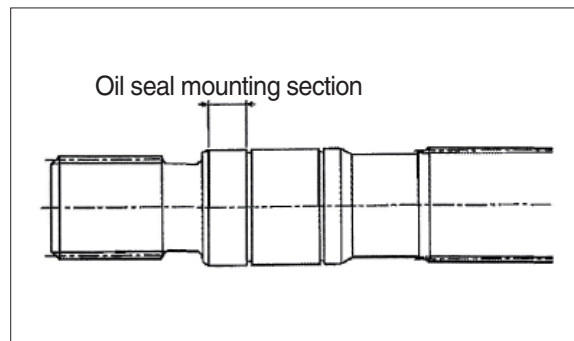

80CR8MP23

(4) Control plate

- Check the slide surface for any damage.  
When the damage is large replace the control plate with new one.

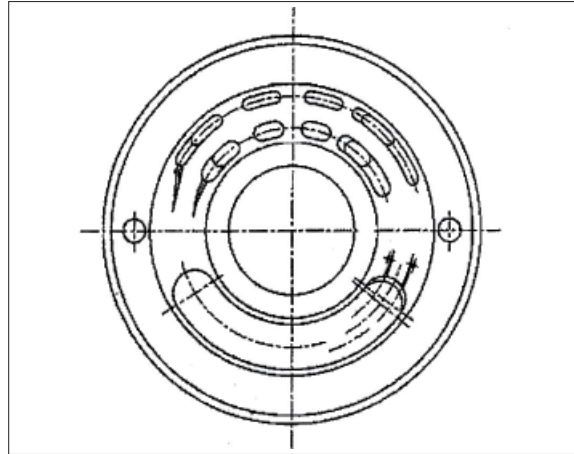

80CR8MP24

(5) Guide and retainer

- Check for scouring or stepped wear.  
If this can not be corrected replace the guide and the retainer as a set.
- Fine scouring or damage can be corrected with lapping.  
Carry out through washing after lapping.

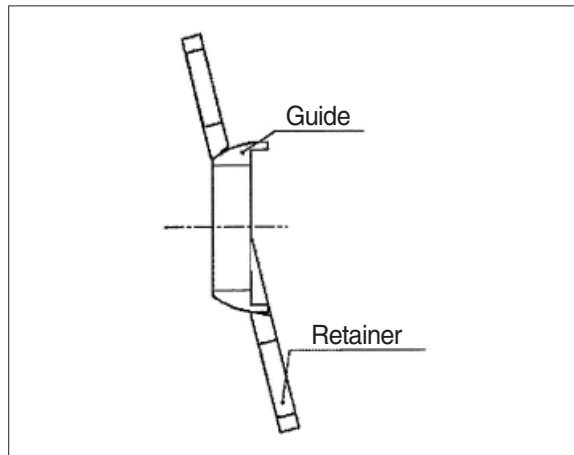

80CR8MP25

(6) Guide and swash plate

- Check for scouring or stepped wear.  
If this can not be corrected replace the guide and the swash plate as a set.

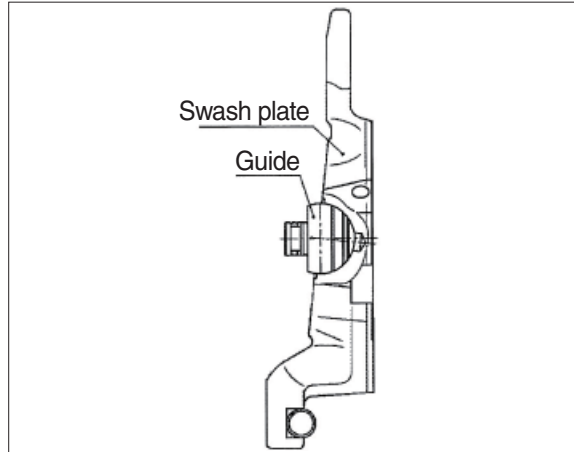

80CR8MP26

## 5) ASSEMBLING PROCEDURE (main pump)

### (1) Assemble the swash plate

- ① Assemble the ball guides to housing.  
Check the position of O-ring and backup ring.  
Apply the grease to the guide axis for the dropout prevention.

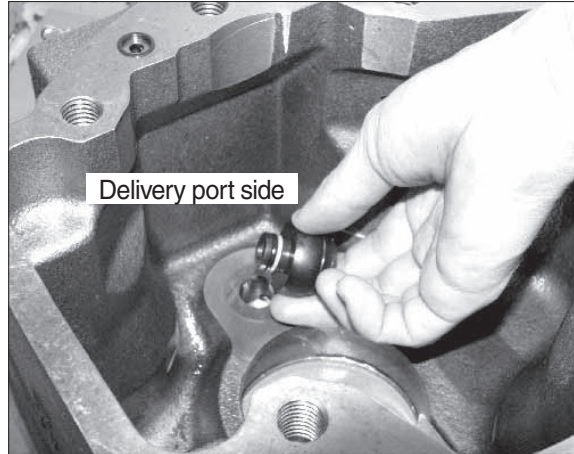
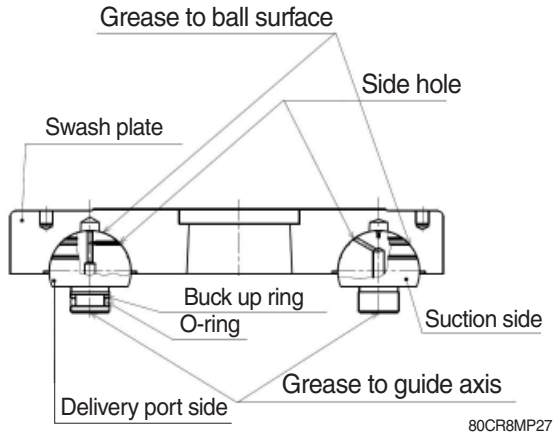

80CR8MP28

- ② Fix the position of side holes and apply grease to the whole of ball surfaces.

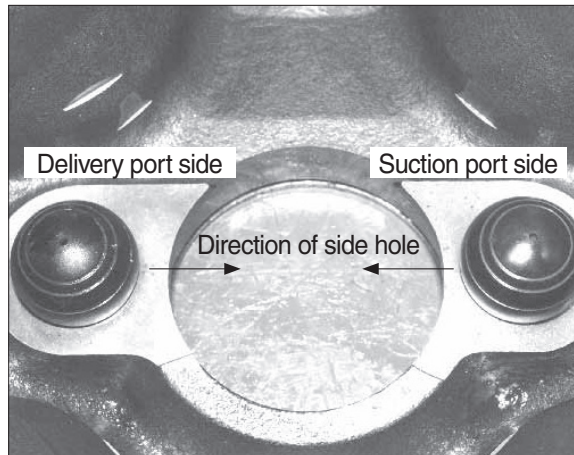

80CR8MP29

- ③ Install the swash plate.

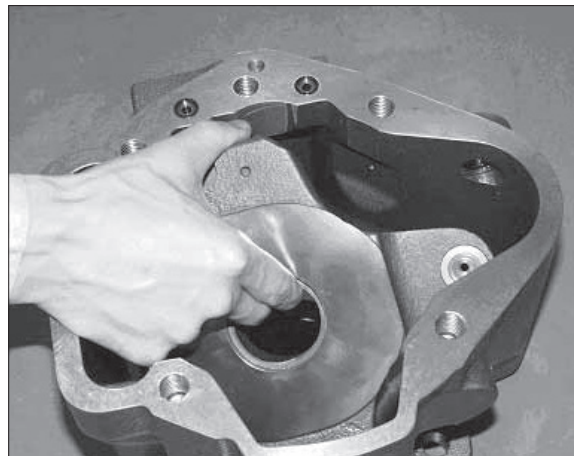

80CR8MP30

(2) Assemble the shaft

- ① Install the shaft into the housing with taking care not to drop swash plate out. Fix the bearing outer ring firmly into the housing hole.

When the shaft doesn't build in easily, you can use a plastic hammer and hit a shaft end of front side lightly.

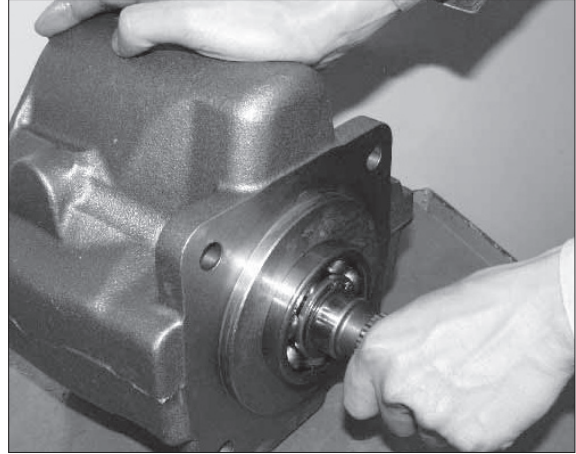

80CR8MP31

- ② Apply the grease to O-ring and assemble it.

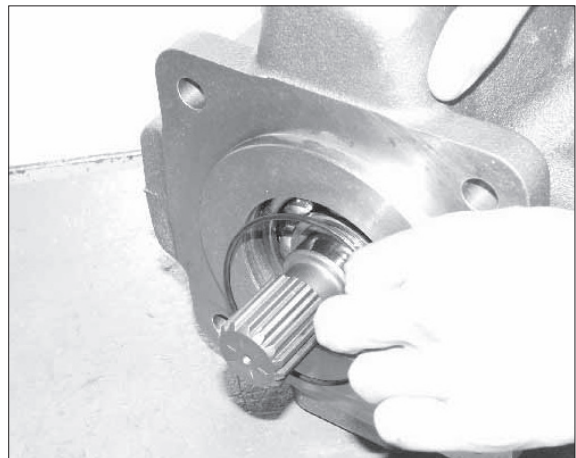

80CR8MP32

- ③ Install the oil seal case into the shaft. Apply grease to the oil seal lip beforehand. Be careful not to damage shaft seal with spline.

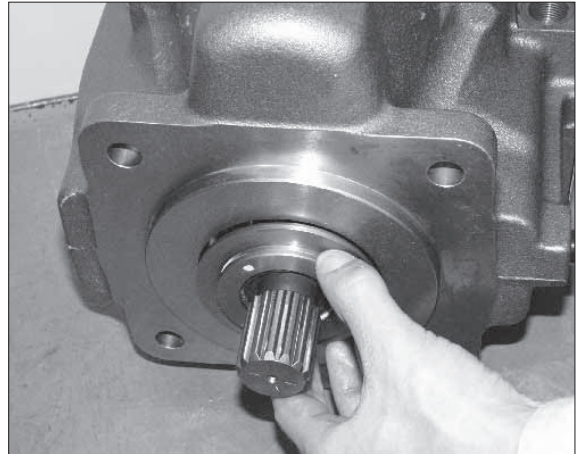

80CR8MP33

- ④ Assemble the retaining ring.  
(For bore use ; 80)
- Pliers for retaining rings  
(For bore use ; retaining ring for 80)

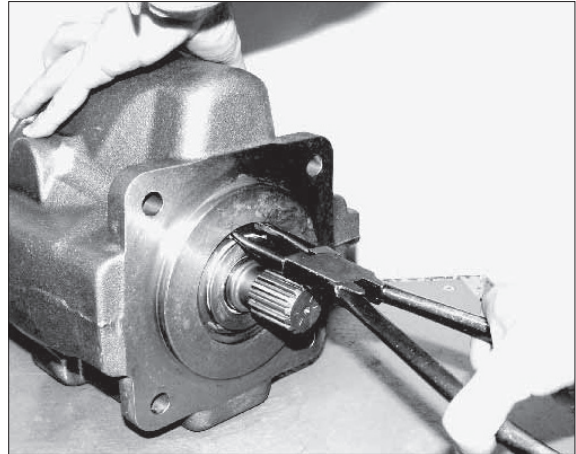

80CR8MP34

- (3) Assemble the rotary group.
- ① Apply the grease to the parallel pins  
( $\varnothing 3 \times 30$ , 3 pieces) and install them to  
the ditch part of spline.



80CR8MP35

- ② Apply the grease to the surface of  
retaining ball and assemble it on the  
pins.

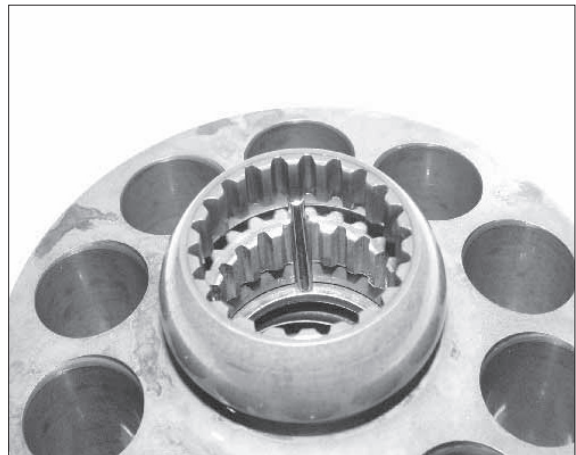

80CR8MP36



- ③ Apply the grease to the end part of the shoes and assemble the piston assembly into the hole of retaining plate and cylinder block.



80CR8MP37

- (4) Install the rotary group.  
(Along the shaft spline)

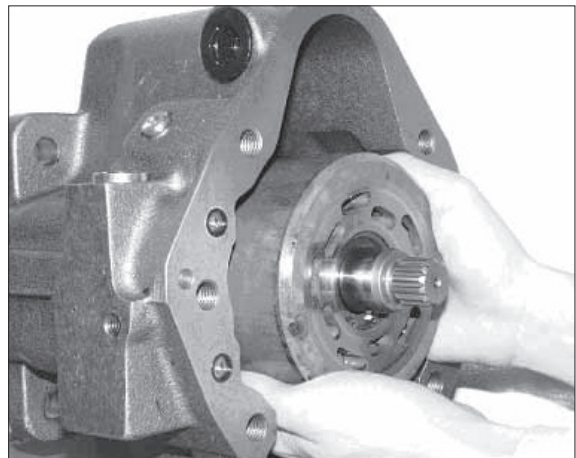

80CR8MP38

- (5) Assemble the spring seat assembly.  
① Apply the grease to the ball surface of spring seat and assemble it.

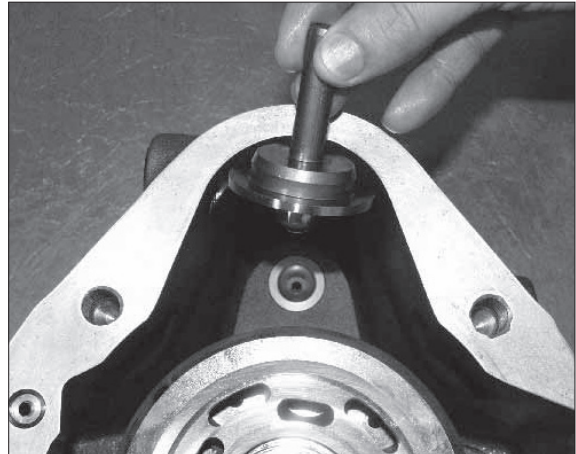

80CR8MP39

- ② Assemble the springs (inner and outer) and the guide.

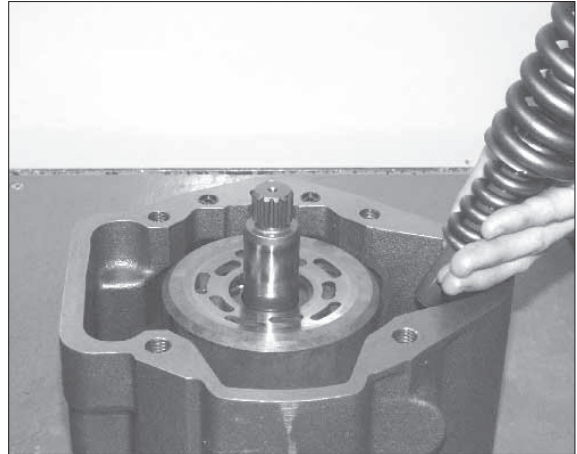

80CR8MP40

- ③ Install the spring seat into the port plate.

Apply grease to the shim for dropout prevention when shim has attached to the spring seat.

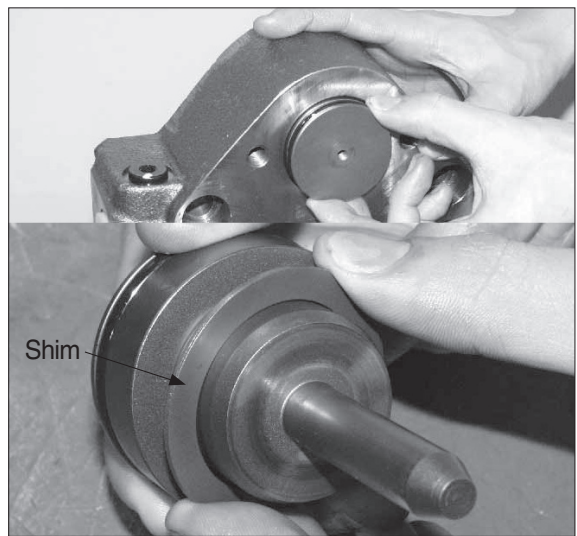

80CR8MP20

- ④ Assemble the cover.  
Fix the hexagon socket head cap screws.  
(M10×30, 2 pieces)

Hexagon socket screw key  
(Hexagon side distance : 8 mm)

Tightening torque :  $6.3 \pm 0.7$  kgf · m  
( $45.6 \pm 5.2$  lbf · ft)

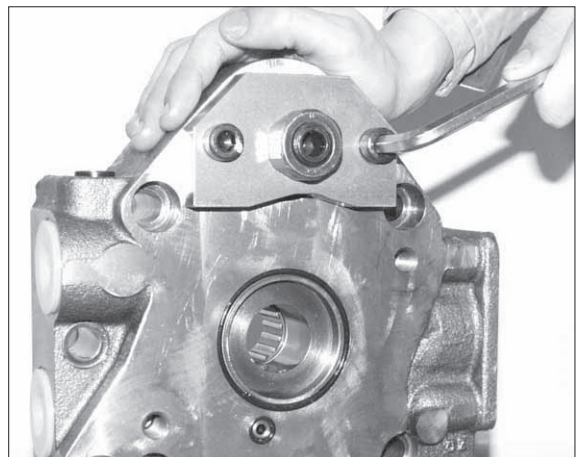

80CR8MP41

(6) Assemble the control piston assembly.

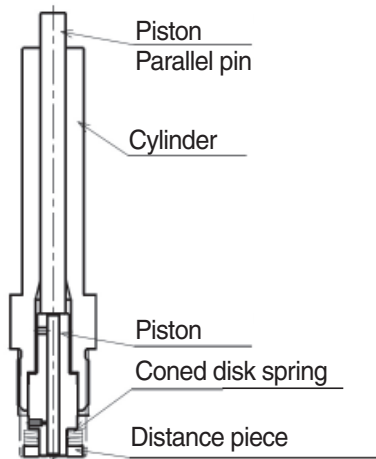

80CR8MP43

Apply three bond #1305 to the thread of the cylinder.

Spanner (27 mm)

Tightening torque :  $14.5 \pm 1.4 \text{ kgf} \cdot \text{m}$   
 $(105 \pm 10.3 \text{ lbf} \cdot \text{ft})$

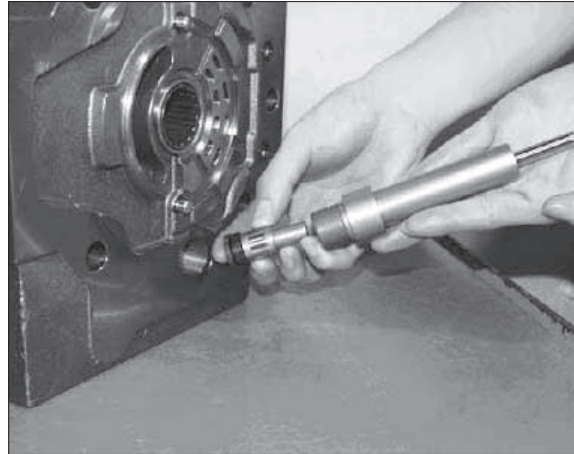

80CR8MP42

(7) Assemble the control plate.

- ① Apply the grease between port plate and control plate for dropout prevention and assemble the control plate to the port plate.
- ② Apply the grease to the operating surface of control plate.

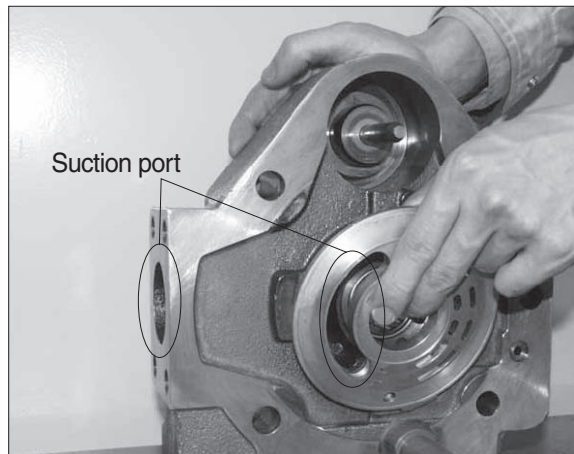

80CR8MP44

(8) Assemble the port plate assembly.

- ① Assemble the square rings to the housing side and port plate side (each 2 pieces).
- ② Assemble the gasket on the housing surface.

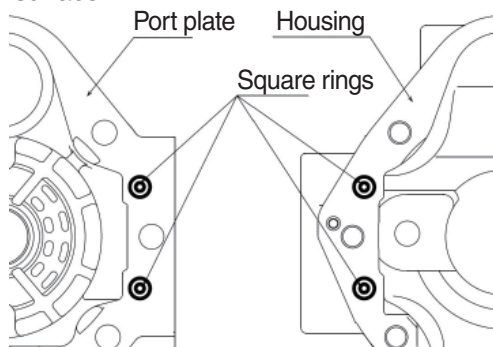

80CR8MP46

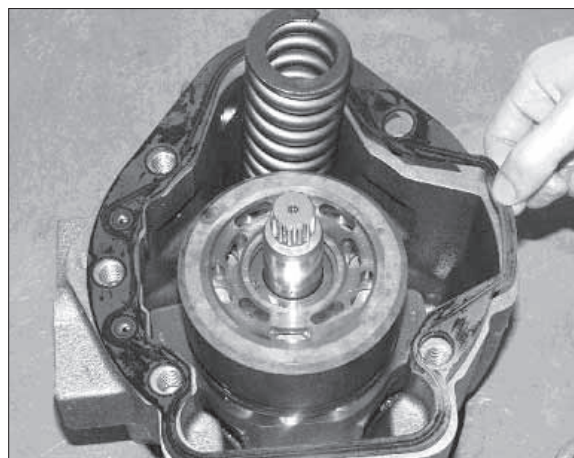

80CR8MP45



- ③ Fix the port plate with the hexagon socket head cap screw.  
(M14×70, 4 pieces)  
(M14×65, 1 pieces)

Hexagon socket screw key  
(Hexagon side distance : 12 mm)  
Tightening torque :  $16.8 \pm 1.5$  kgf · m  
( $122 \pm 11.1$  lbf · ft)

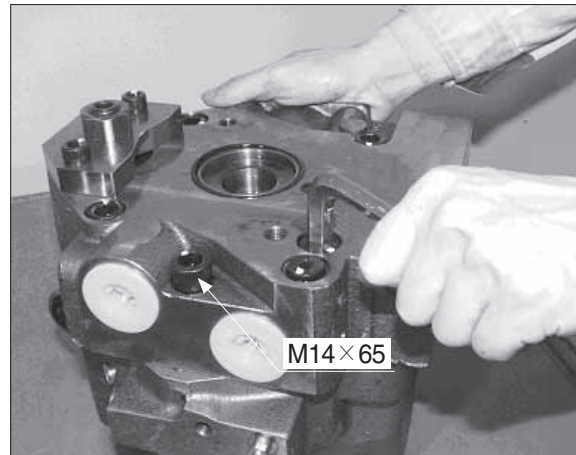

80CR8MP47

- (9) Assemble the rear pump.  
Install the coupling.  
Confirm the O-rings.

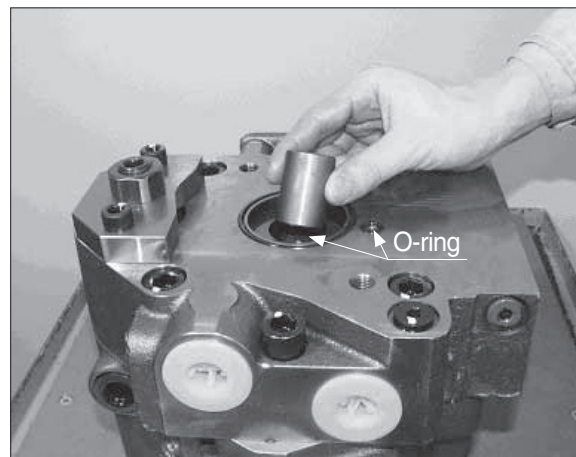

80CR8MP48

- ① Fix the rear pump with the hexagon socket head cap screws.  
(M12×30, 2 pieces)

Hexagon socket screw key  
(Hexagon side distance : 10 mm)  
Tightening torque :  $11.2 \pm 1.2$  kgf · m  
( $81.1 \pm 8.9$  lbf · ft)

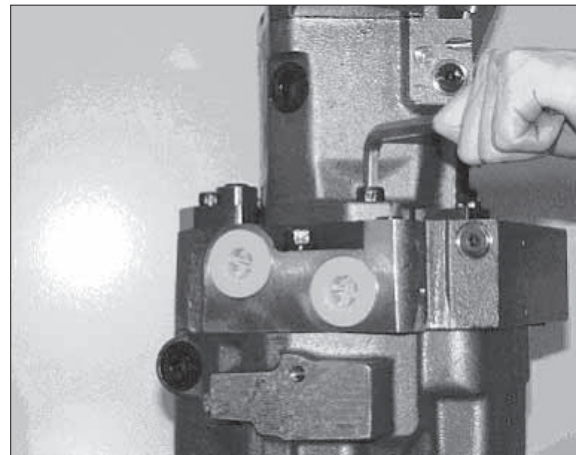

80CR8MP49

## 6) DISASSEMBLING PROCEDURE (rear pump)

### (1) Remove the flange.

Remove the hexagon socket head cap screws.

(M10×45, 2 pieces, M10×20, 2 pieces)

Hexagon socket screw key

(Hexagon side distance : 8 mm)

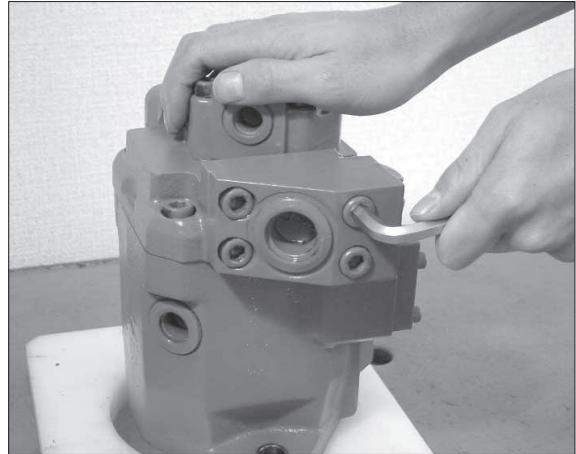

80CR8MP50

### (2) Remove the plug.

Spanner (32 mm)

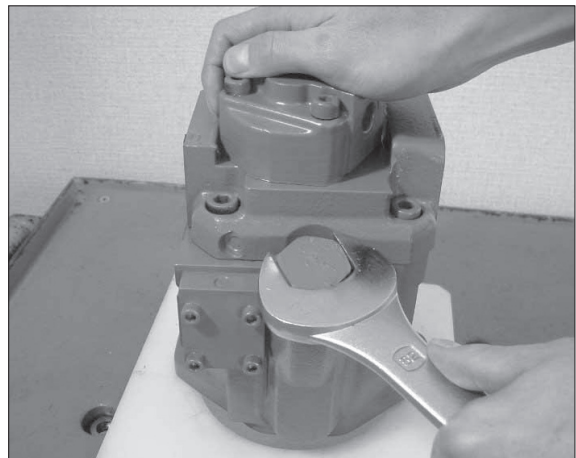

80CR8MP51

### (3) Remove the gear pump.

Remove the hexagon socket head cap screws.

(M8×50, 4 pieces)

Hexagon socket screw key

(Hexagon side distance : 6 mm)

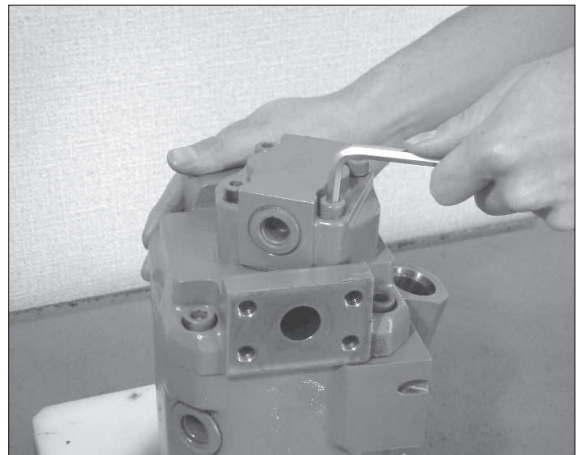

80CR8MP52

(4) Remove the port plate.

① Remove the hexagon socket head cap screws.

(M10×30, 4 pieces)

Hexagon socket screw key

(Hexagon side distance : 8 mm)

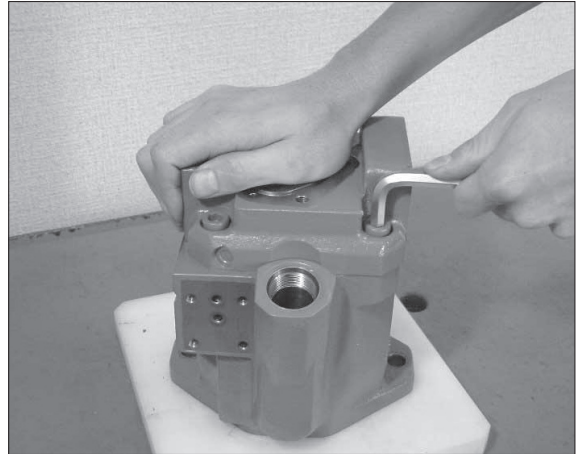

80CR8MP53

② Remove the port plate.

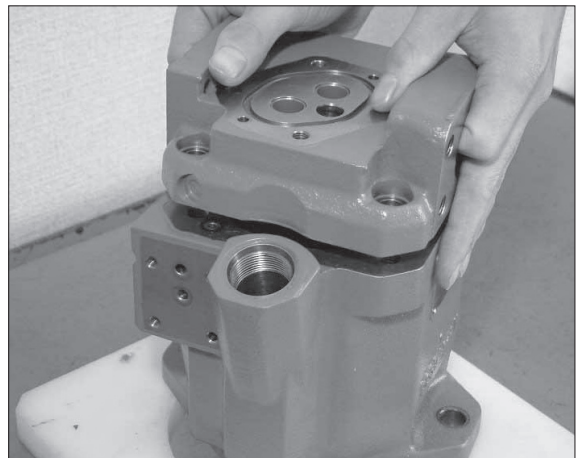

80CR8MP54

③ Remove the control plate from the port plate.

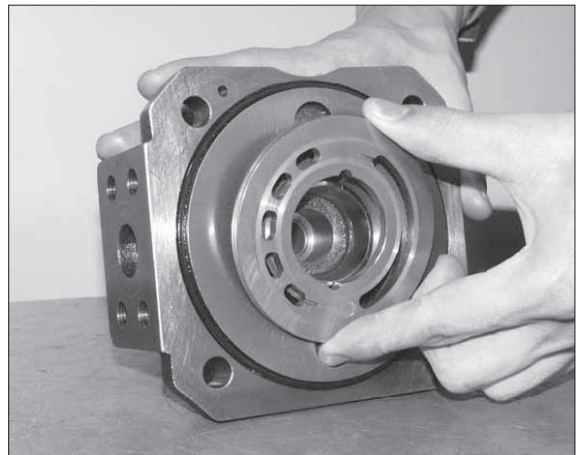

80CR8MP55

(5) Remove the parts from the pump housing.

① Remove the coupling.

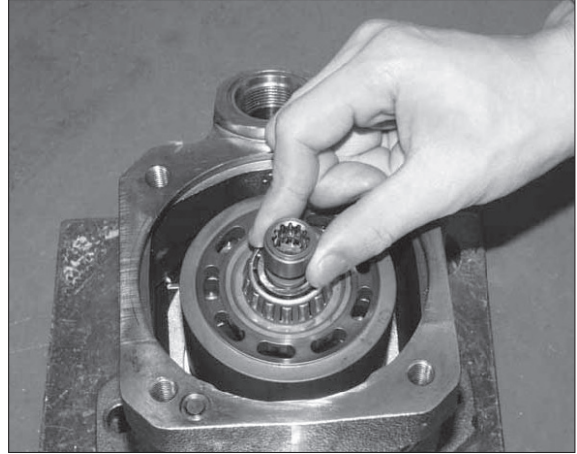

80CR8MP56

② Remove the bearing.

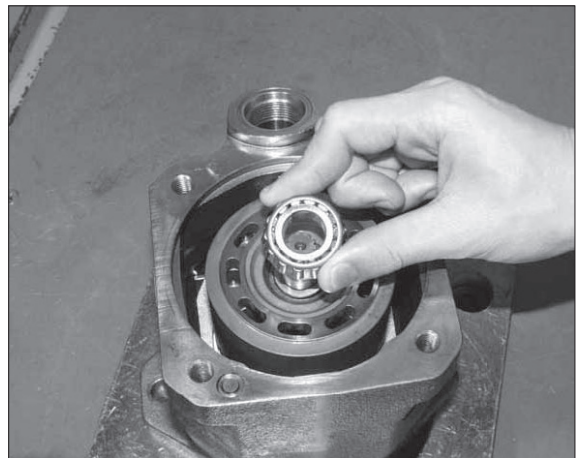

80CR8MP57

③ Remove the shim.

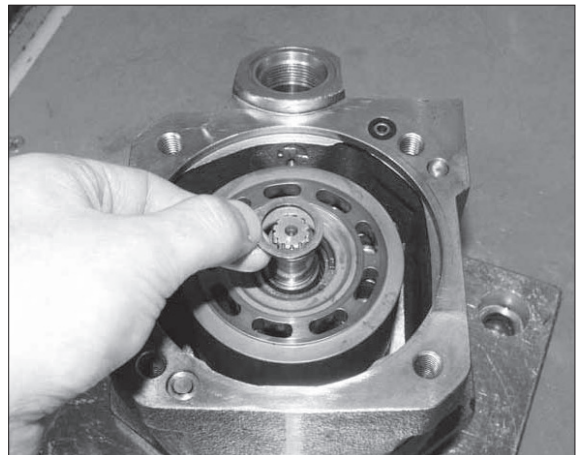

80CR8MP58



- ④ Remove the rotary group.

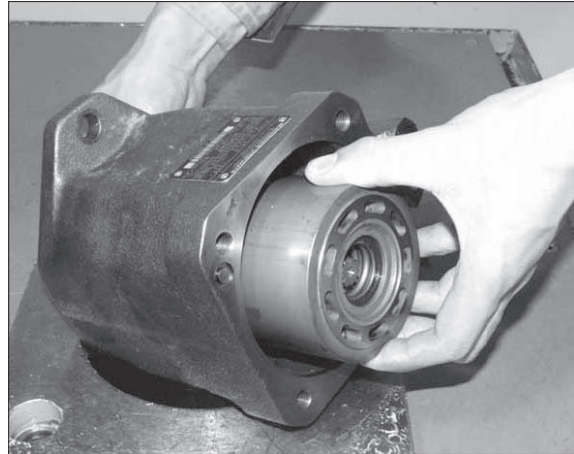

80CR8MP59

- ⑤ Remove the swash plate and the drive shaft.

Note the spring that is on the back side of the swash plate.

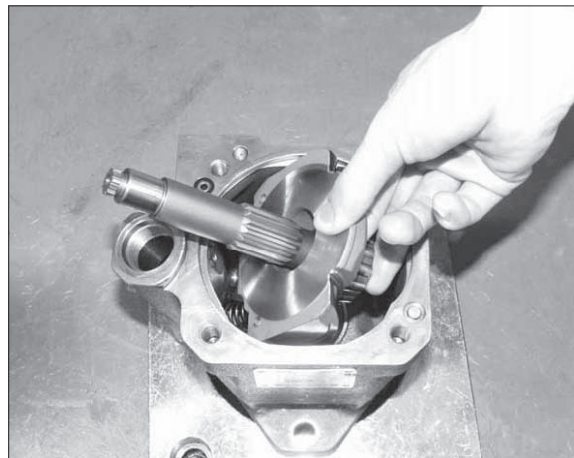

80CR8MP60

- ⑥ Remove the cradle shells.

Mark the cradle shells so that it should not make a mistake in the position of a low-pressure side and a high-pressure side.

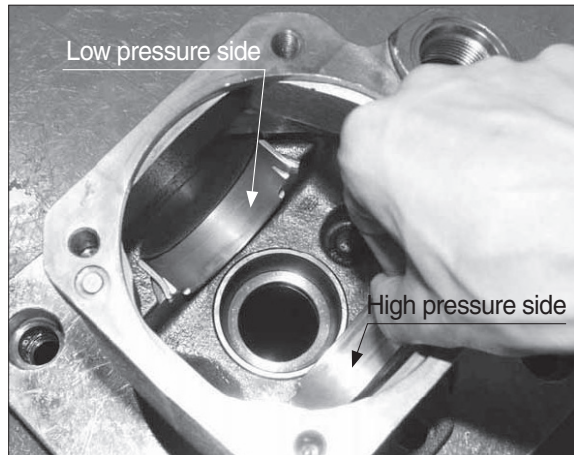

80CR8MP61

(4) Disassemble the gear pump.

- ① Remove the drive gear and the side plate.

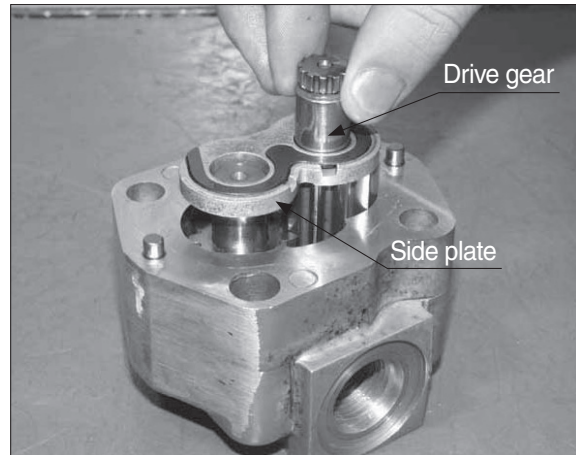

80CR8MP62

- ② Remove the idle gear.

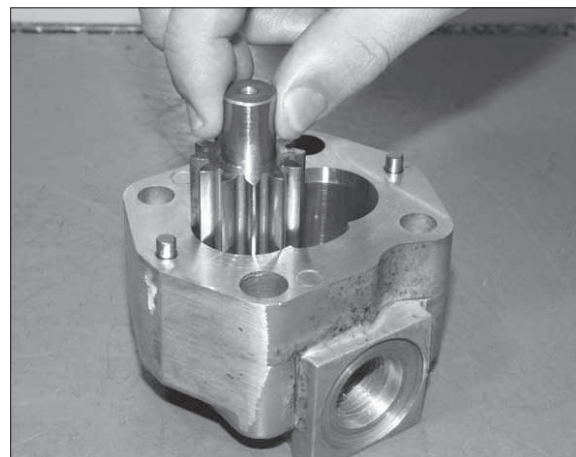

80CR8MP63

## 7) MAINTENANCE AND SERVICE STANDARD FOR THE REAR PUMP

Before inspection wash the parts well and dry them completely.

Inspect the principal parts with care and replace them with new parts when any abnormal wear exceeding the allowable limit or damage considered harmful is found.

Replace the seal also when any remarkable deformation and damage are found.

### (1) Piston assembly and cylinder block

- Check the appearance visually.  
No damage showing abnormal wear (particularly in the side portion) should be found.
- Check the clearance between the piston outside dia and the cylinder block inside dia.  
 $D-d \leq 0.06 \text{ mm}$

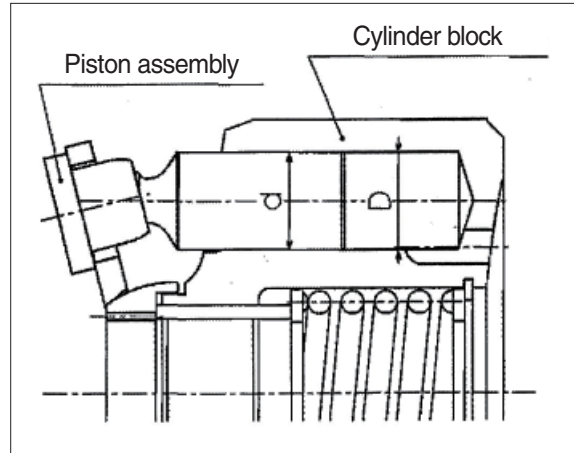

80CR8MP21

### (2) Piston shoe and piston

- Check the piston shoe.  
 $\varepsilon \leq 0.2 \text{ mm}$

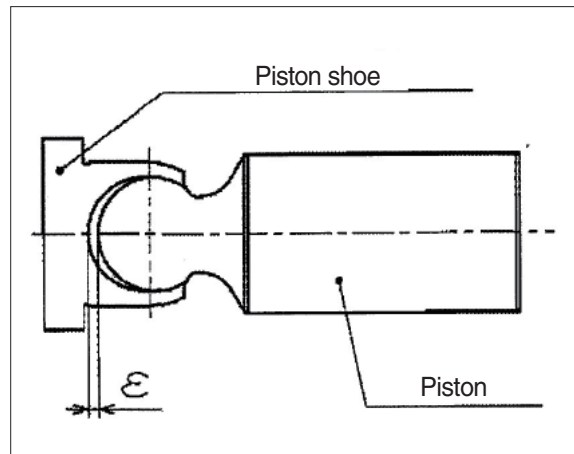

80CR8MP22

### (3) Control plate

- Check the slide surface for any damage.  
When the damage is large replace the control plate with new one.

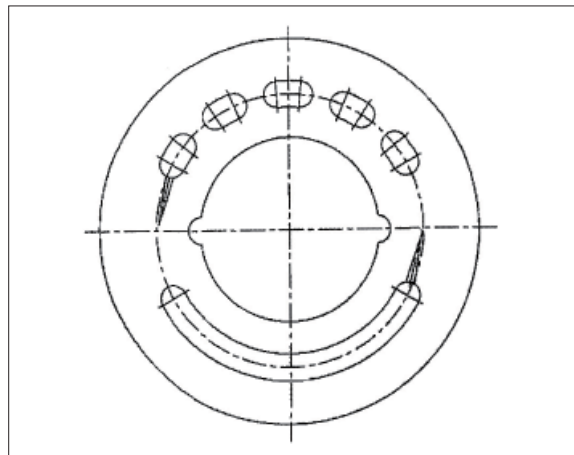

80CR8MP64

- (4) Retaining ball and retaining plate
- Check for scouring or stepped wear.  
If this can not be corrected replace the retaining ball and the retaining plate as a set.
  - Fine scouring or damage can be corrected with lapping.  
Carry out through washing after lapping.

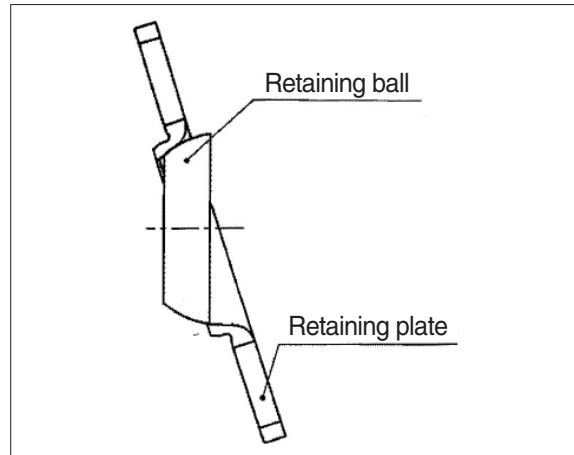

80CR8MP65

- (5) Swash plate and ball stop and cradle shells
- Check for scouring or stepped wear.  
If this can not be corrected replace the swash plate and the ball stop and the cradle shells as a set.

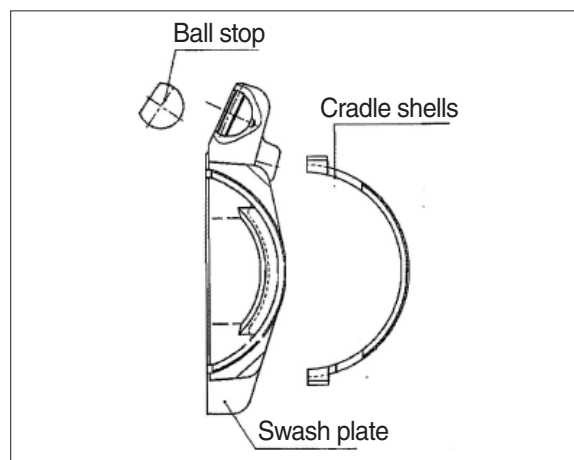

80CR8MP66



## 8) ASSEMBLING PROCEDURE (rear pump)

(1) Assemble the swash plate and the drive shaft.

① Assemble the cradle shells.

Note the mark of the low-pressure side and the high-pressure side if you use the disassembled parts again.

② Assemble the spring.

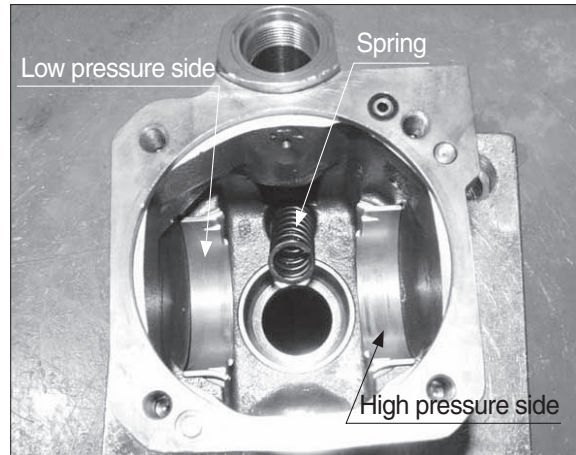

80CR8MP67

③ Assemble the swash plate with the drive shaft.

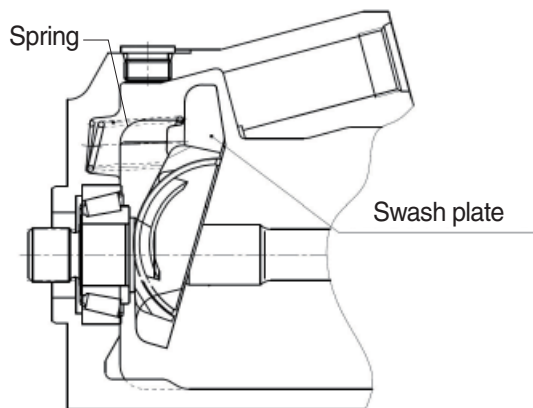

80CR8MP69

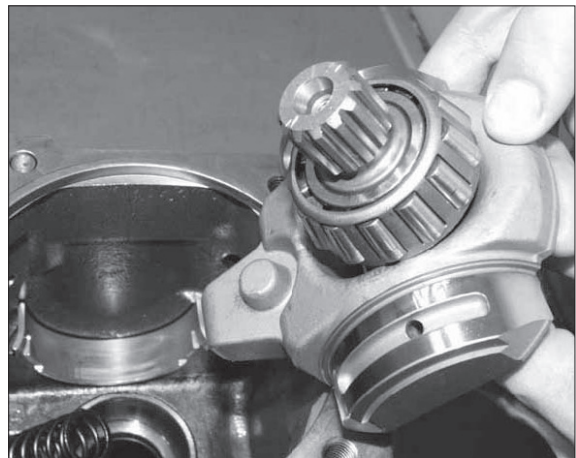

80CR8MP68

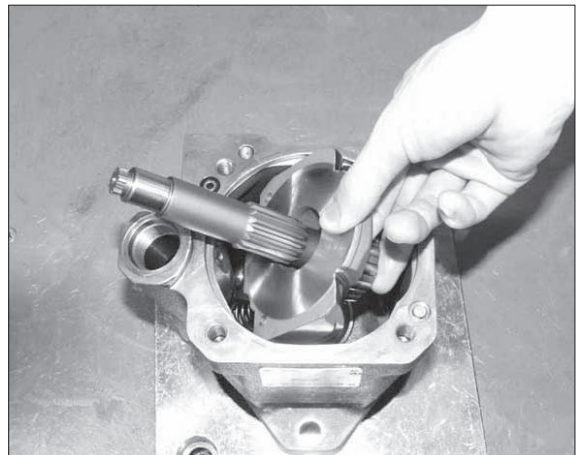

80CR8MP70

(2) Assemble the rotary group.

- ① Apply the grease to the surface of retaining ball and assemble it along the cylinder block spline.

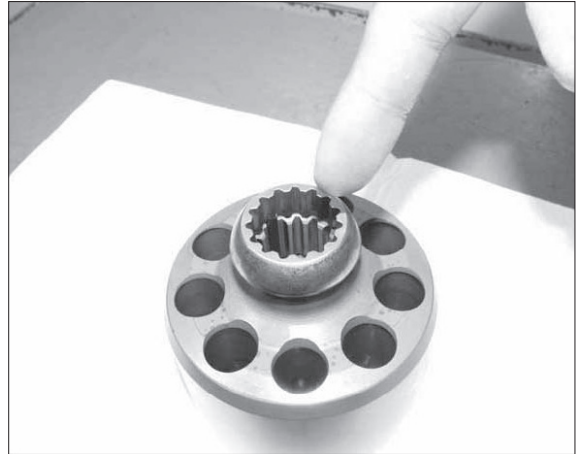

80CR8MP71

- ② Apply the grease to the end part of the shoes and assemble the piston complete into the hole of retaining plate and cylinder block.

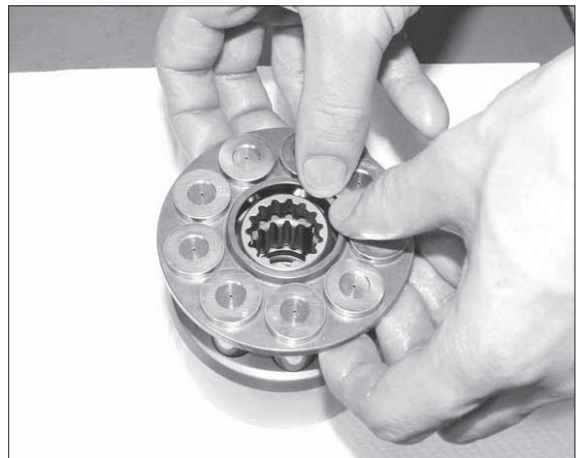

80CR8MP72

(3) Install the rotary group.  
(Along the shaft spline)

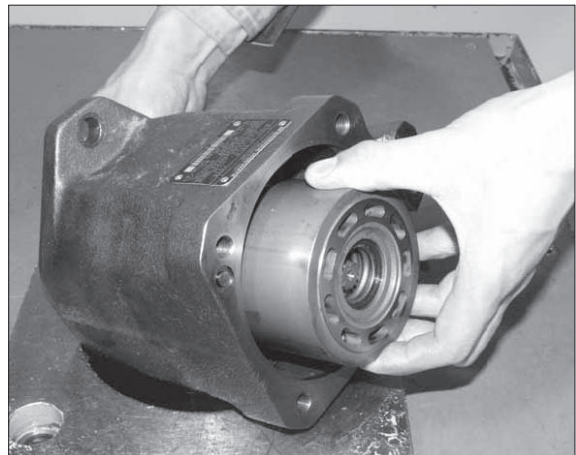

80CR8MP73

(4) Assemble the shim and the bearing and the coupling

- ① Assemble the shim to the drive shaft.
- ② Assemble the bearing on the shim.
- ③ Assemble the coupling to the drive shaft.

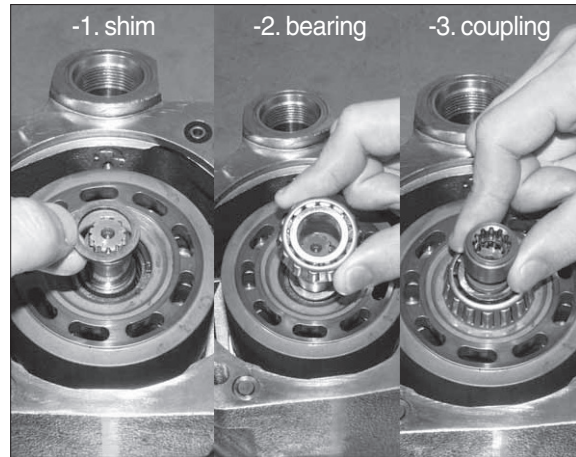

80CR8MP74

(5) Apply the grease between port plate and control plate for dropout prevention and assemble the control plate to the port plate.

Confirm the O-ring.

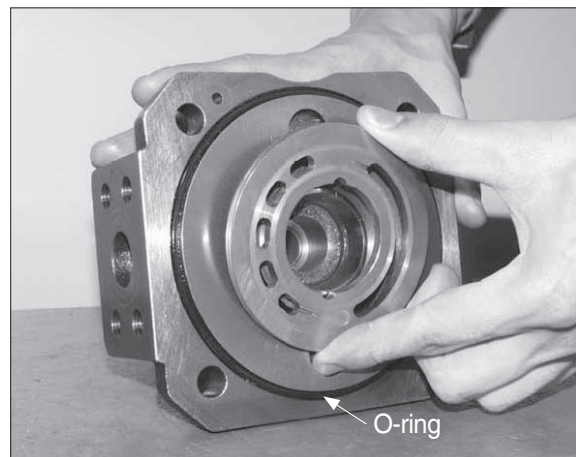

80CR8MP75

(6) Assemble the port plate.  
Confirm the square ring.

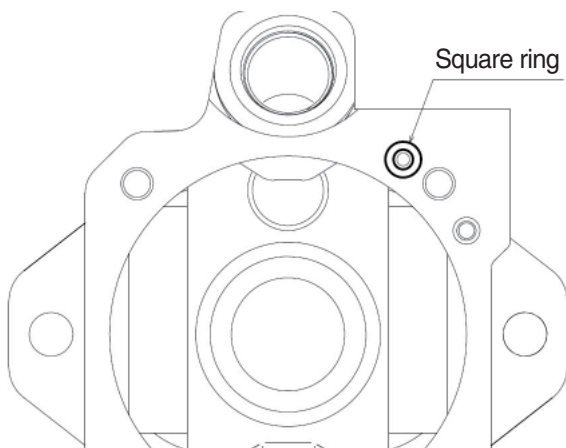

80CR8MP76

(M10 × 30, 4 pieces)

Hexagon socket screw key  
(Hexagon side distance : 8 mm)

Tightening torque :  $6.3 \pm 0.71$  kgf · m  
( $45.7 \pm 5.2$  lbf · ft)

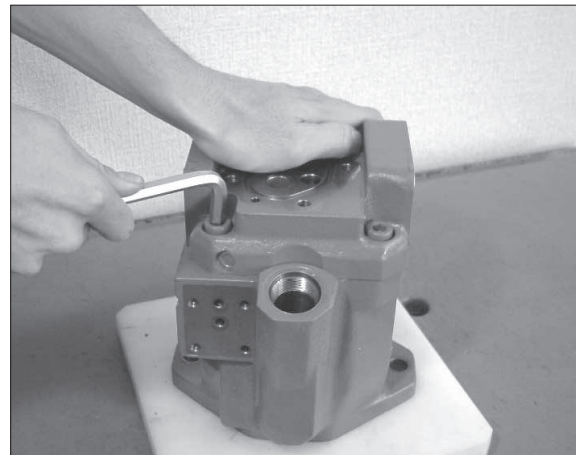

80CR8MP77

(7) Assemble the gear pump.

① Install the drive gear and the idle gear.

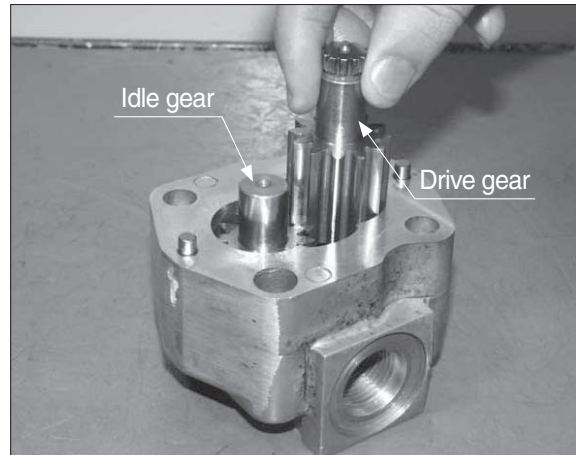

80CR8MP78

② Apply the grease to the square ring and the backup ring for dropout prevention and install the rings into the side plate.

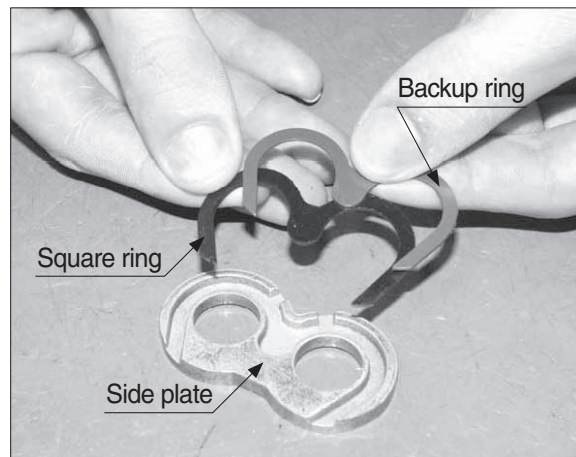

80CR8MP79

③ Apply the grease to the side plate for dropout prevention and assemble it.

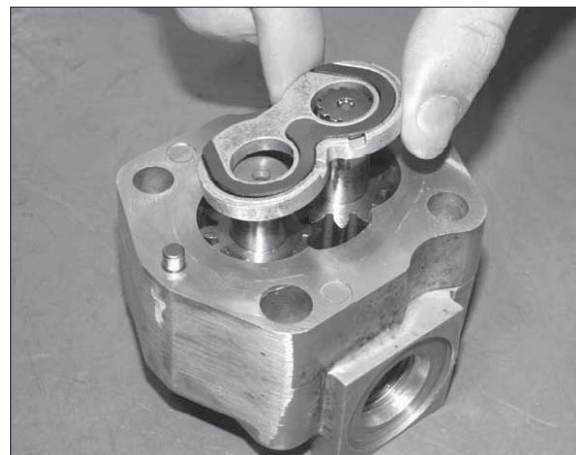

80CR8MP80



- (8) Assemble the gear pump on the port plate.  
Confirm the O-ring.

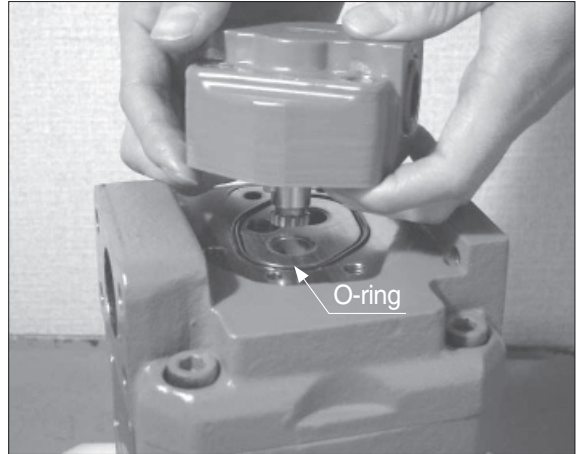

80CR8MP81

Hexagon socket head cap screws  
(M8×50, 4 pieces)

Hexagon socket screw key  
(Hexagon side distance : 6 mm)

Tightening torque :  $3.26 \pm 0.31$  kgf · m  
( $23.6 \pm 2.2$  lbf · ft)

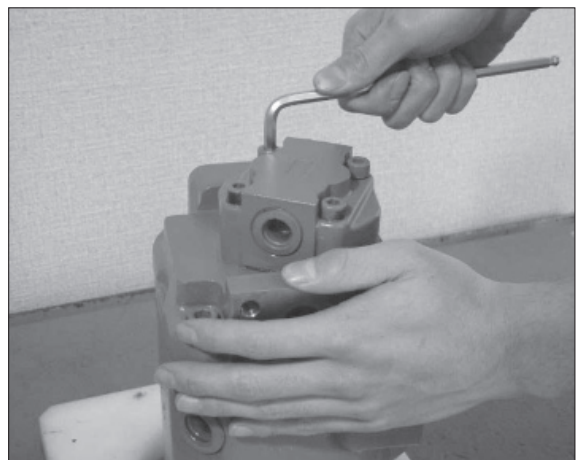

80CR8MP82

(9) Assemble the plug.

Confirm that the planar section of the ball stop is upward.

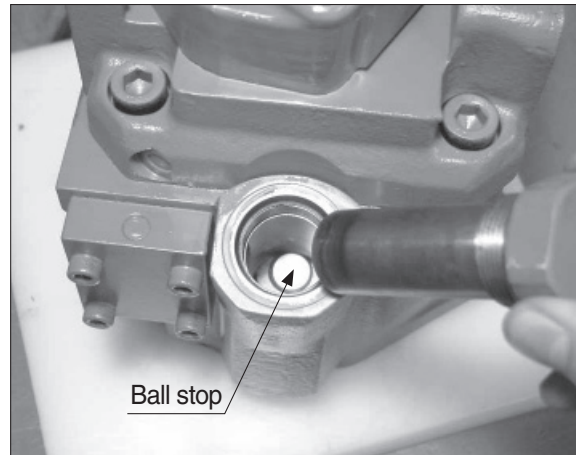

80CR8MP83

Spanner (32 mm)

Tightening torque : 15.3 kgf · m (111 lbf · ft)

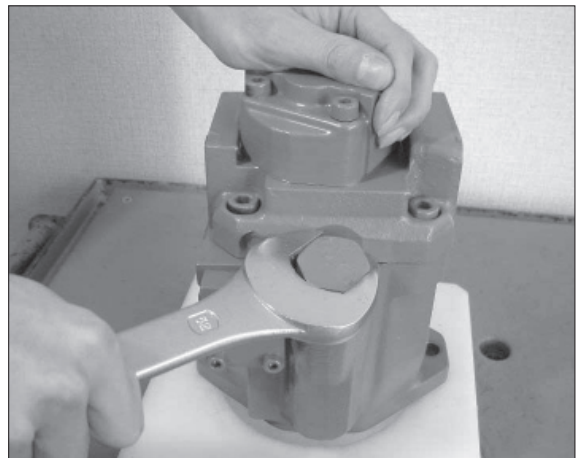

80CR8MP84

(10) Assemble the flange.

Hexagon socket head cap screws  
(M10×45, 2 pieces, M10×20, 2 pieces)

Hexagon socket screw key  
(Hexagon side distance : 8 mm)

Tightening torque :  $6.3 \pm 0.7$  kgf · m  
( $45.6 \pm 5.2$  lbf · ft)

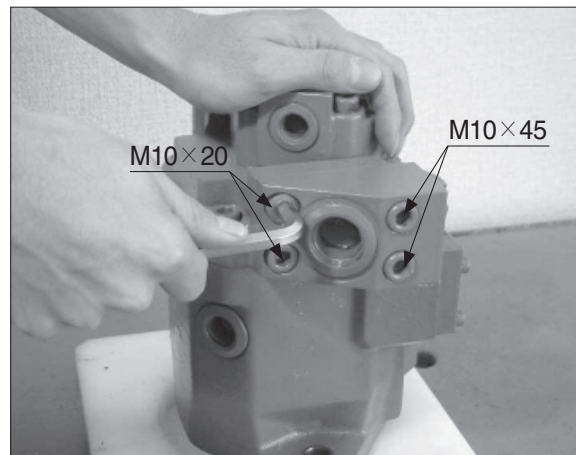

80CR8MP85



## GROUP 4 MAIN CONTROL VALVE

### 1. REMOVAL AND INSTALL OF MOTOR

#### 1) REMOVAL

- (1) Lower the work equipment to the ground and stop the engine.
- (2) Operate the control levers and pedals several times to release the remaining pressure in the hydraulic piping.
- (3) Loosen the breather slowly to release the pressure inside the hydraulic tank.
- ▲ **Escaping fluid under pressure can penetrate the skin causing serious injury.**
- ※ When pipes and hoses are disconnected, the oil inside the piping will flow out, so catch it in oil pan.
- (4) Disconnect hydraulic hose.
- (5) Disconnect pilot line hoses.
- (6) Remove links.
- (7) Sling the control valve assembly and remove the control valve mounting bolt.
  - Weight : 40 kg (90 lb)
- (8) Remove the control valve assembly.  
When removing the control valve assembly, check that all the piping have been disconnected.

#### 2) INSTALL

- (1) Carry out installation in the reverse order to removal.
- (2) Bleed the air from below items.
  - ① Cylinder (boom, arm, bucket)
  - ② Swing motor
  - ③ Travel motor※ See each item removal and install.
- (3) Confirm the hydraulic oil level and recheck the hydraulic oil leak or not.

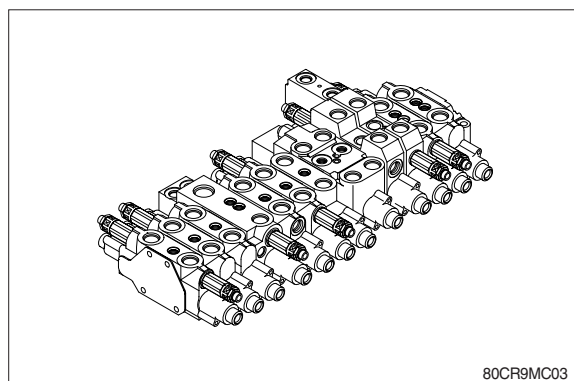
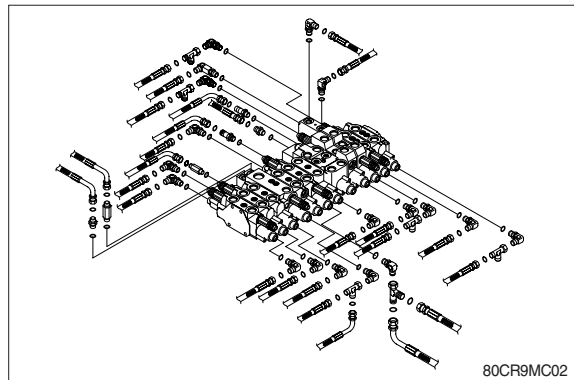
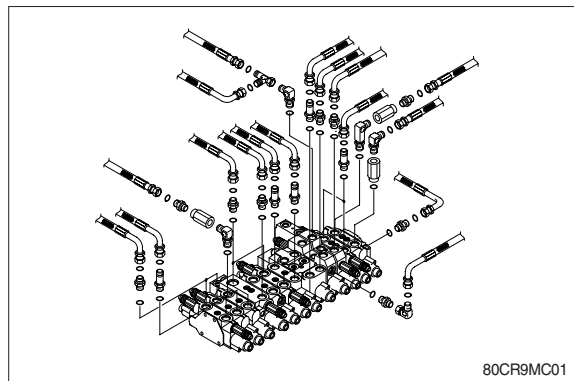

## 2. STRUCTURE (1/4)

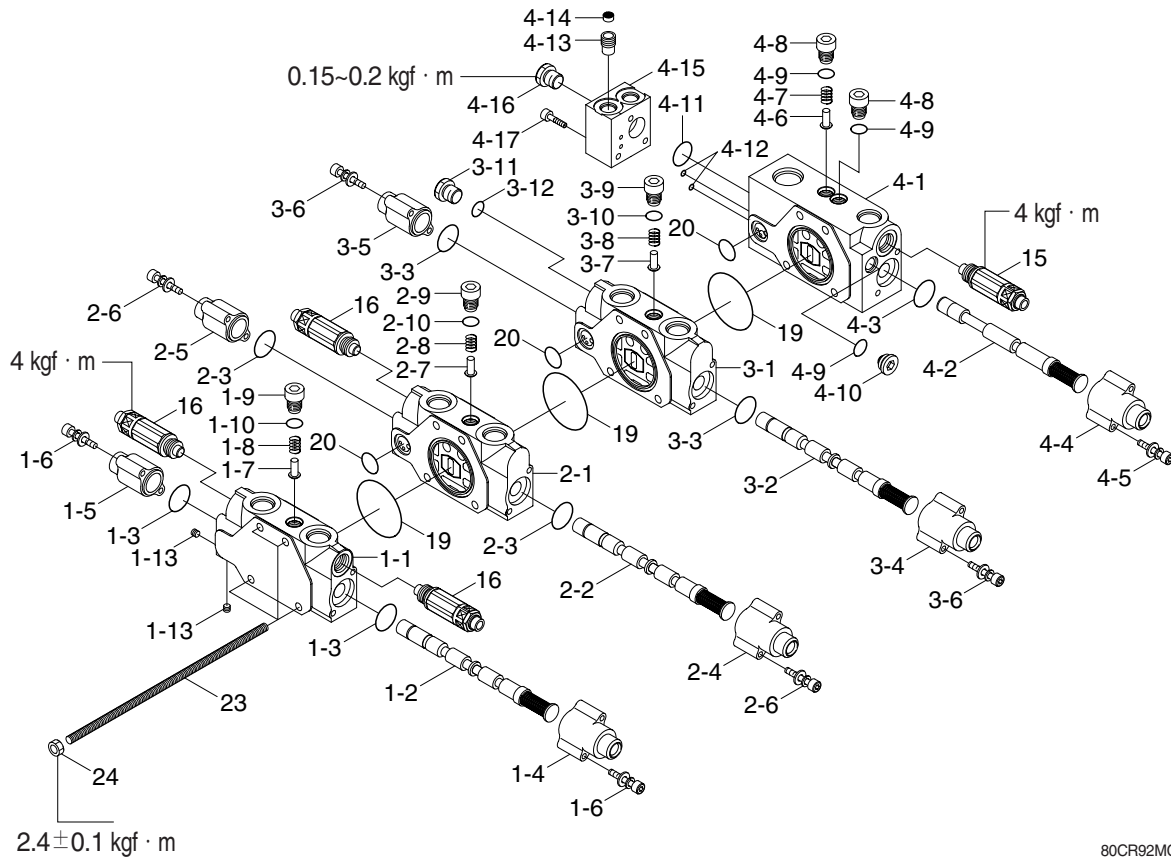

1	Swing block	2-8	Spring	4-4	Pilot cover
1-1	Work body	2-9	Check valve plug	4-5	Socket bolt
1-2	Swing spool assy	2-10	O-ring	4-6	Check valve poppet
1-3	O-ring	3	Boom swing block	4-7	Spring
1-4	Pilot cover	3-1	Work body	4-8	Check valve plug
1-5	Pilot cover	3-2	Boom swing spool assy	4-9	O-ring
1-6	Socket bolt	3-3	O-ring	4-10	Plug
1-7	Poppet	3-4	Pilot cover	4-11	O-ring
1-8	Spring	3-5	Pilot cover	4-12	O-ring
1-9	Check valve plug	3-6	Socket bolt	4-13	Orifice
1-10	O-ring	3-7	Poppet	4-14	Coin type filter
1-13	Plug	3-8	Spring	4-15	Pilot body
2	Dozer block	3-9	Check valve plug	4-16	Plug
2-1	Work body	3-10	O-ring	4-17	Socket bolt
2-2	Dozer spool assy	3-11	Plug	15	Relief valve
2-3	O-ring	3-12	O-ring	16	Relief valve
2-4	Pilot cover	4	Boom 2 block	19	O-ring
2-5	Pilot cover	4-1	Work body	20	O-ring
2-6	Socket bolt	4-2	Boom 2 spool assy	23	Tie bolt
2-7	Poppet	4-3	O-ring	24	Hexagon nut

## STRUCTURE (2/4)

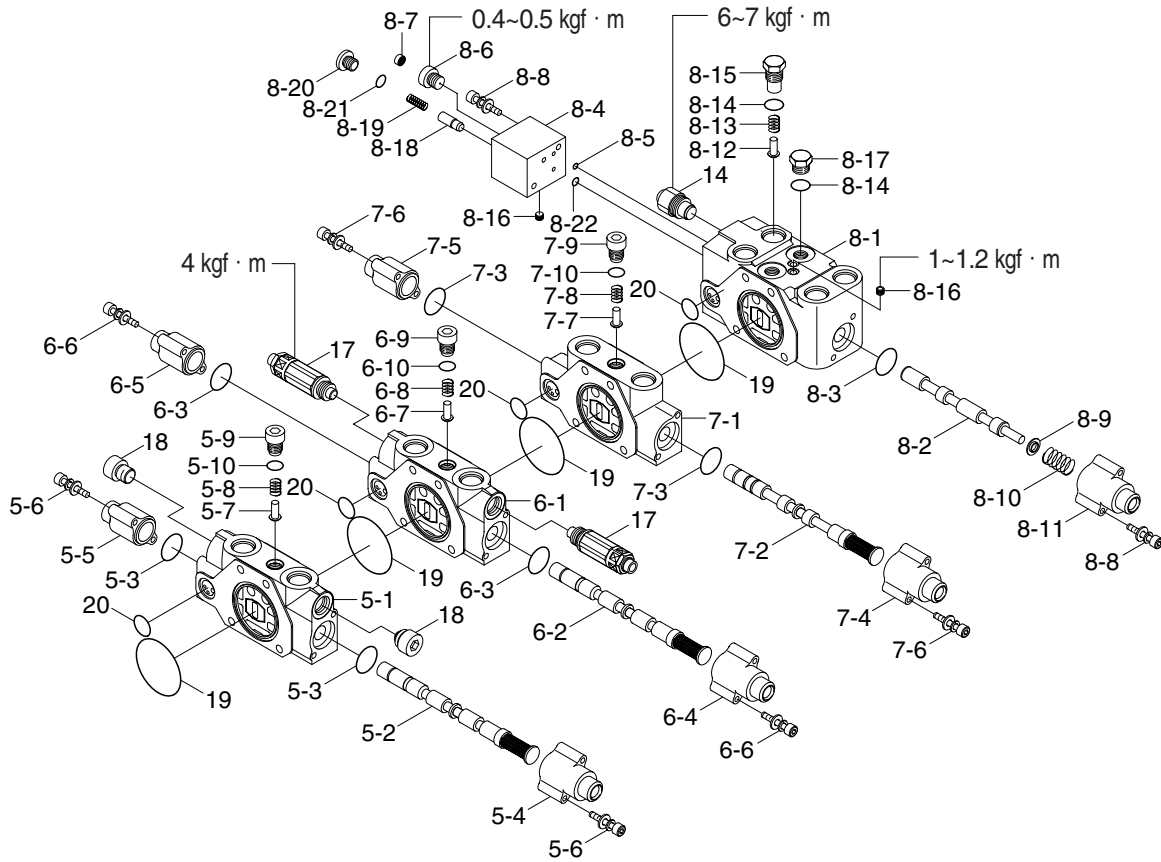

80CR92MC31

5	Service block	6-10	O-ring	8-8	Socket bolt
5-1	Work body	7	Left travel block	8-9	Spring seat
5-2	Service spool assy	7-1	Work body	8-10	Spring
5-3	O-ring	7-2	Travel spool assy	8-11	Pilot cover
5-4	Pilot cover	7-3	O-ring	8-12	Check valve poppet
5-5	Pilot cover	7-4	Pilot cover	8-13	Check valve spring
5-6	Socket bolt	7-5	Pilot cover	8-14	O-ring
5-7	Poppet	7-6	Socket bolt	8-15	Check valve plug
5-8	Spring	7-7	Check valve poppet	8-16	Plug
5-9	Check valve plug	7-8	Spring	8-17	Plug
5-10	O-ring	7-9	Check valve plug	8-18	Check valve
6	Arm block	7-10	O-ring	8-19	Check valve spring
6-1	Work body	8	Straight travel block	8-20	Plug
6-2	Arm spool assy	8-1	Work body	8-21	O-ring
6-3	O-ring	8-2	Travel spool assy	8-22	O-ring
6-4	Pilot cover	8-3	O-ring	14	Main relief valve
6-5	Pilot cover	8-4	Pilot body	17	Relief valve
6-6	Socket bolt	8-5	O-ring	18	Plug
6-7	Poppet	8-6	Orifice	19	O-ring
6-8	Spring	8-7	Coin type filter	20	O-ring
6-9	Check valve plug				

## STRUCTURE (3/4)

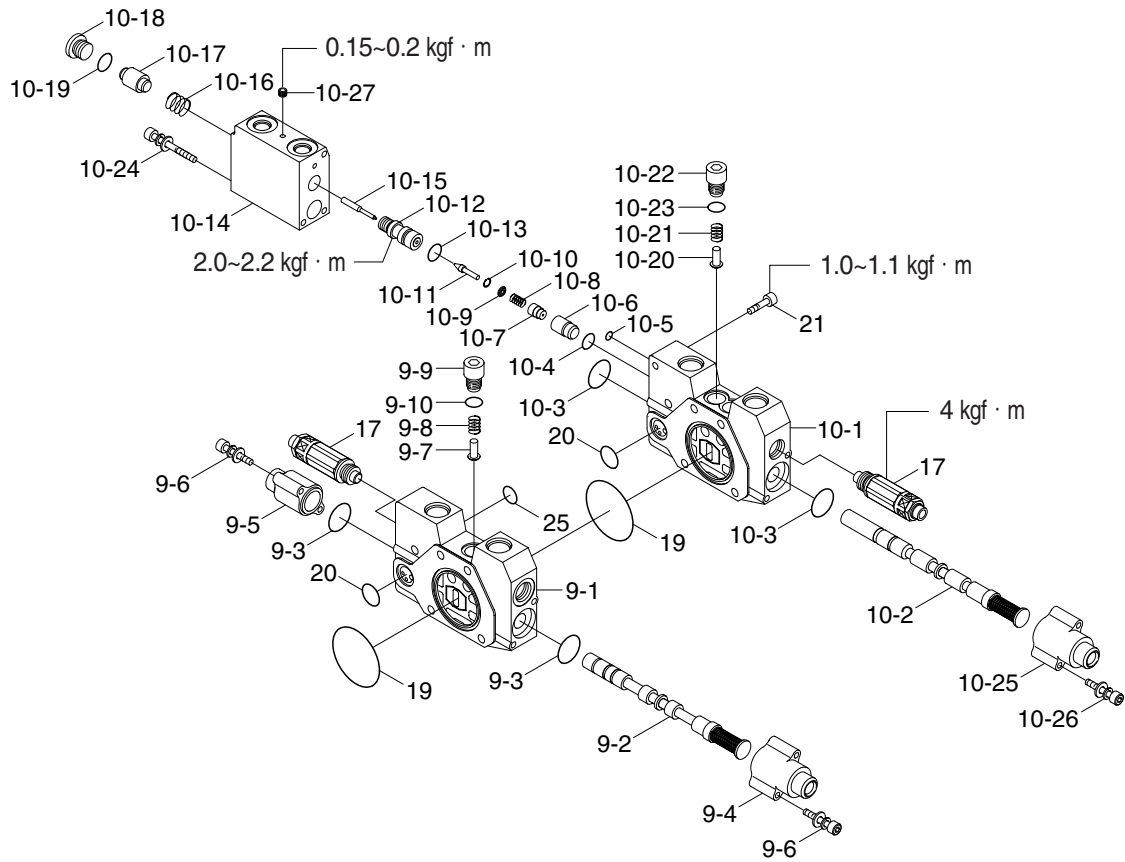

80CR92MC41

9	Right travel block	10-4	O-ring	10-19	O-ring
9-1	Work body	10-5	O-ring	10-20	Poppet
9-2	Travel spool assy	10-6	Lock valve	10-21	Spring
9-3	O-ring	10-7	Lock restrictor	10-22	Check valve plug
9-4	Pilot cover	10-8	Holder spring	10-23	O-ring
9-5	Pilot cover	10-9	Holder spring	10-24	Socket bolt
9-6	Socket bolt	10-10	Retaining ring	10-25	Pilot cover
9-7	Check valve plug	10-11	Poppet	10-26	Socket bolt
9-8	Spring	10-12	Piston guide	10-27	Plug
9-9	Check valve plug	10-13	O-ring	17	Relief valve
9-10	O-ring	10-14	Pilot cover	19	O-ring
10	Boom block	10-15	Piston	20	O-ring
10-1	Work body	10-16	Lock valve spring	21	Socket bolt
10-2	Boom spool assy	10-17	Piston	25	O-ring
10-3	O-ring	10-18	Plug		

## STRUCTURE (4/4)

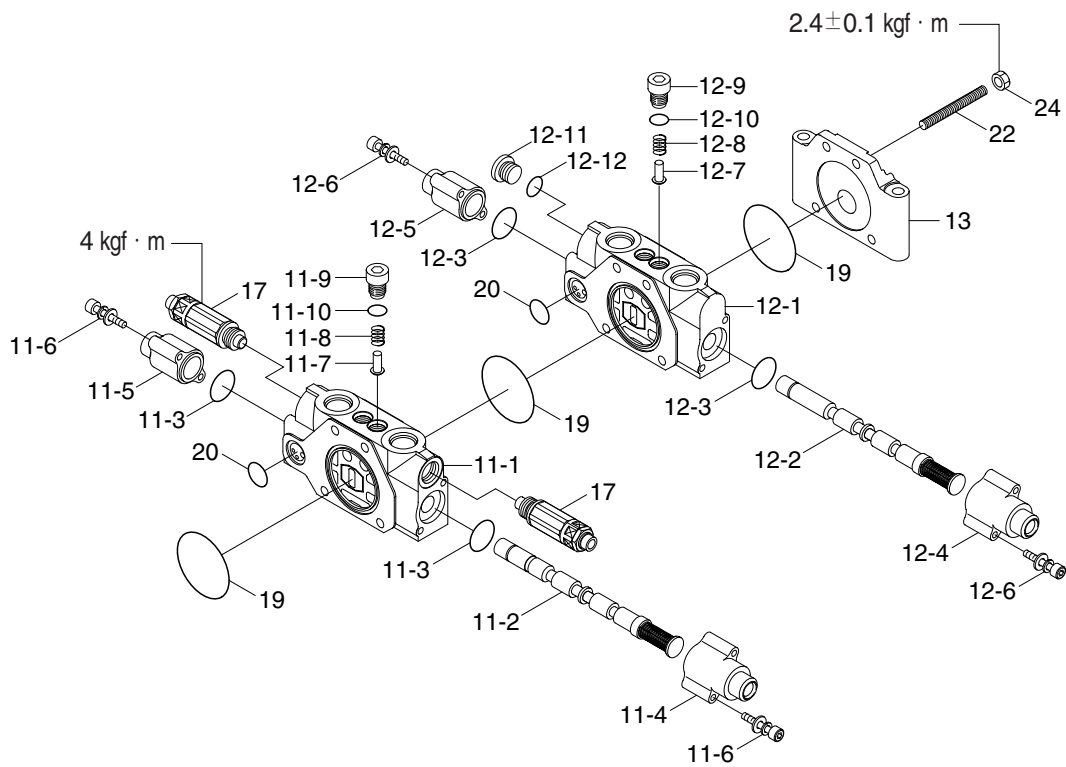

80CR92MC51

11	Bucket block	11-10	O-ring	12-9	Check valve plug
11-1	Work body	12	Arm 2 block	12-10	O-ring
11-2	Bucket spool assy	12-1	Work body	12-11	Plug
11-3	O-ring	12-2	Arm 2 spool assy	12-12	O-ring
11-4	Pilot cover	12-3	O-ring	13	End cover
11-5	Pilot cover	12-4	Pilot cover	17	Relief valve
11-6	Socket bolt	12-5	Pilot cover	19	O-ring
11-7	Poppet	12-6	Socket bolt	20	O-ring
11-8	Spring	12-7	Poppet	22	Tie bolt
11-9	Check valve plug	12-8	Spring	24	Hexagon nut

### 3. DISASSEMBLY

#### 1) PRECAUTIONS FOR DISASSEMBLY

- (1) Since hydraulic devices are all machined precisely with clearances being very little, carry out the disassembly and assembly work at a clean place and make sure to prevent the device from being entered with dust, sand, and the like.
  - (2) Before disassembly work, prepare necessary material such as the structural drawing for control valve to fully understand the structure and others.
  - (3) When removing the control valve from the machine, put a dustproof cap on each port and then clean the outside of assembly after checking the installation of caps.  
Furthermore, prepare a suitable workbench with clean paper or rubber mat on it for the work.
  - (4) Since there is a possibility of rust when the disassembled parts are left, apply anti-corrosive oil to the parts and seal them.
  - (5) Hold the control valve body when carrying or moving. Especially, do not hold the exposed spool after removing a pilot cover from the control valve.
  - (6) Do not hit the control valve even if it does not move smoothly.
  - (7) It is recommend carrying out various tests (relief valve setting, leak test, internal pressure loss check, etc.) after the disassembly and assembly of the control valve, which requires a hydraulic test device.  
Accordingly, when the disassembly might be possible technically but the test and/or adjustment might be impossible, do not carry out the work.
- ▲ Before removing the pipes, attach suitable indications on them to be able to locate their positions later. If there is a mistake in piping between the ports, unintentional movement could result in an accident.
  - ▲ Falling or hitting the control valve could bend the spool, which could result in an accident.
  - ▲ If foreign matter enters each port, there could be a control valve malfunction, resulting in an accident.
  - ▲ Since the load side port could hold an empty weight or enclosed pressure, release the inside pressure before loosening the piping.  
There could be a fall of attachments or a jet of high-temperature hydraulic fluid.
  - ▲ The control valve becomes high temperature after operating the machine; after checking that the temperature becomes low, start the work.
  - ▲ The control valve has complicated connections and seals through the internal passages, which means that there could be enclosed pressure, resulting in an oil jet after disassembly.  
Wear safety goggles during disassembly work because there could be a blow off of parts if they are caught.



## 2) NECESSARY TOOLS AND OTHERS

(1) Before disassembling the control valve, prepare the following tools.

The tools below are used to disassemble this control valve only; tools for disassembling the port fittings are not included.

Name of tool	Quantity	Size (mm)
Hexagonal wrench	Each 1	4, 5, 6, 8 and 10
Screw wrench	Each 1	13, 19, 21, 22 and 30
Socket wrench	Each 1	13, 19, 21, 22 and 30
Torque wrench	1	0.2 ~ 2.0 kgf · m (1.4 ~ 14.5 lbf · ft)
Torque wrench	1	2.0 ~ 12.0 kgf · m (14.5 ~ 86.8 lbf · ft)
Magnet	1	-
Pliers	1	-
Slotted screwdriver	1	-
Tweezers	1	-

Prepare clean wash oil, hydraulic fluid, grease, tag paper, marker pen and others before work.

## 3) DISASSEMBLY OF EACH PART

Before disassembly work, check that there is no dust on the outside of the control valve and then place it on a workbench with actuator ports facing upward.

The numbers in ( ) in the explanation and in ○ in the figures show reference numbers in the parts table in the specifications and drawings.

## (1) Spool draw-out procedures

### ■ Except P1, P2 inlet & straight travel block

Taking the dozer spool as an example, the draw-out procedures are as follows.

- ① Remove 2 hex socket head bolt with washer (⑥) with 5 mm hexagonal wrench.
- ② Remove pilot cover (④).
- ③ With a spring in the dozer spool exposed, pull out spool assy from the control valve slowly and horizontally (parallel to spool sleeve) by holding spring.
- ④ The other spools can also be pulled out in the same manner.
  - At this time, check O-ring (③) is on the bottom of body side flange.

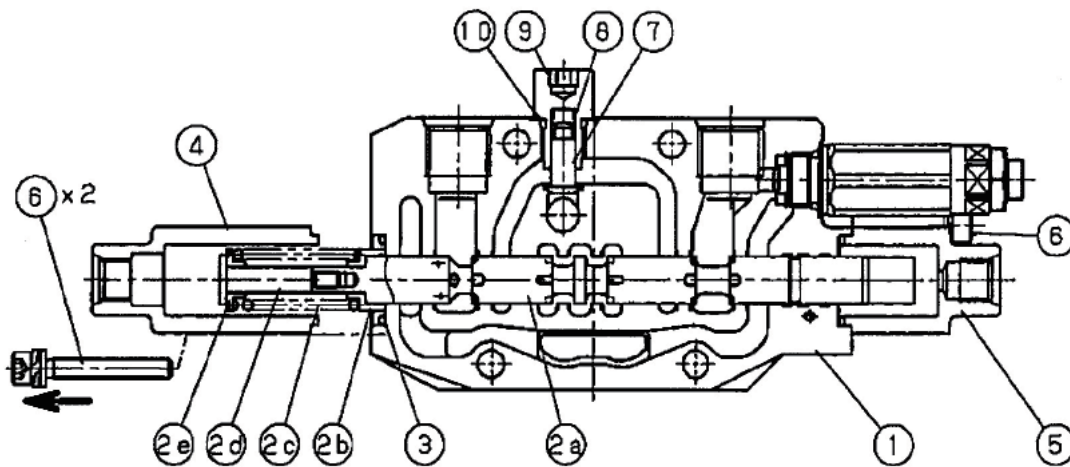

80CR97MCV01

1	Work body	2d	End spool	6	Hex socket head bolt with washer
2	Dozer spool assy	2e	Spring seat	7	Check valve poppet
2a	Dozer spool	3	O-ring	8	Check valve spring
2b	Spring seat	4	Pilot cover	9	Check valve plug
2c	Spring	5	Pilot cover	10	O-ring

### ■ P1, P2 inlet & straight travel block

The draw-out procedures for the straight travel spool are as follows.

- ① Remove 2 hex socket head bolt with washer (⑧) with 5 mm hexagonal wrench.
- ② Remove pilot cover (⑪).
- ③ With spring and the end of straight travel spool exposed from spool sleeve, pull out spring at first, and pull out spool from the control valve slowly and horizontally (parallel to spool sleeve) by holding spring.
  - At this time, check O-ring (③) is on the bottom of body side flange.

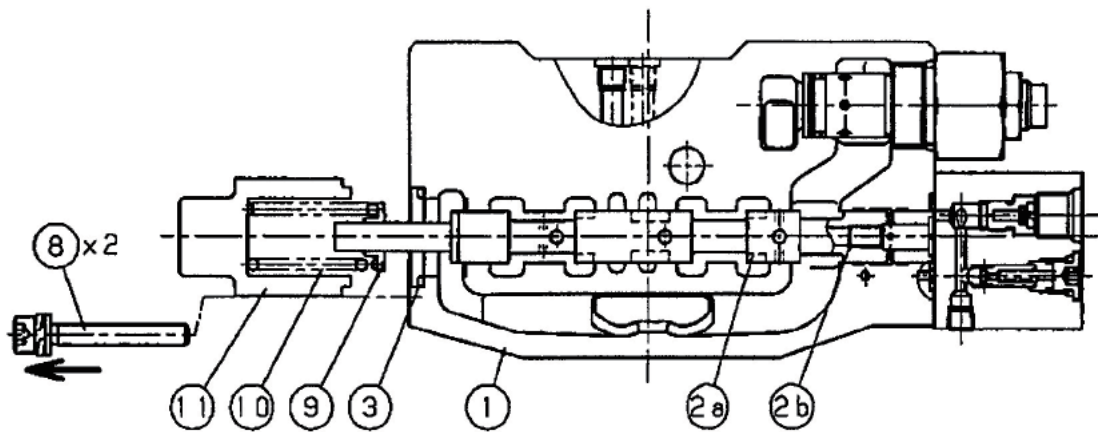

80CR97MCV02

- |    |                            |    |                                  |
|----|----------------------------|----|----------------------------------|
| 1  | Work body                  | 8  | Hex socket head bolt with washer |
| 2  | Straight travel spool assy | 9  | Spring seat                      |
| 2a | Straight travel spool      | 10 | Spring                           |
| 2b | Plug                       | 11 | Pilot cover                      |
| 3  | O-ring                     |    |                                  |

## (2) Check valve disassembly procedures

### ■ Standard type check valve (see figure 4)

- ① Hold the control valve body at workbench or hold it by two or more people.
- ② Loosen and remove check valve plug (⑨) at the center of the control valve upper surface with 8 mm hexagonal wrench.  
When it is hard to loosen the plug because O-ring (⑩) bites the screw, do not loosen forcibly, refasten it once and then try to loosen again.
- ③ From the hole where check valve plug has been removed, remove check valve spring (⑧) and check valve (⑦) with tweezers or magnet.

- The numbers in figure 4 are the same as those in the P1, P2 inlet & straight travel block in the specifications and drawings.
- Except for the P1, P2 inlet & straight travel block the shape of check valve is different, however, they can be disassembled in the same manner.
- The numbers in figure 5 are the same as those in the P3 inlet & boom 2 block in the specifications and drawings.
- The numbers in figure 6 are the same as those in the dozer block in the specifications and drawings.

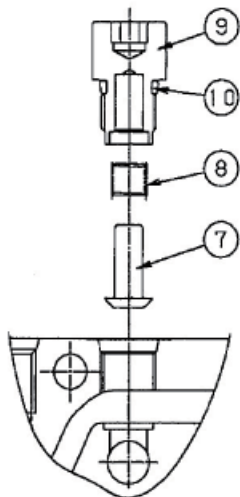

Figure 4. Check valve  
(P1, P2 inlet & straight travel)

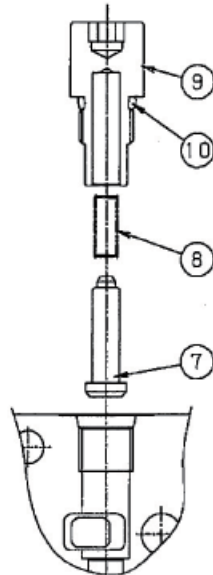

Figure 5. Check valve  
(P3 inlet & boom 2, travel)

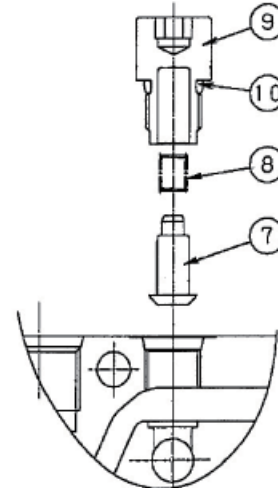

Figure 6. Check valve  
(Swing & boom swing, dozer,  
arm 3 & boom 3, service,  
arm, boom, bucket, arm 2)

80CR97MCV03

### (3) Accessory valve removal procedures

- ※ Accessory valves are the most important parts for performance and safety; in particular, the relief valve is very difficult to readjust the setting so that replace the accessory valve as assy if any malfunction occurs.

#### ■ Removing main relief valve (MRV1) : see page 2-9 and 7-44

- ① Loosen and remove main relief valve (14) with 30 mm screw wrench or socket wrench.
  - Put screw wrench (or socket wrench) to 30 mm hexagonal part of pressure regulating body.
  - Check O-ring and back-up ring are on the part of main relief valve seat.
- ※ Do not put 19 mm screw wrench to the lock nut part when removing.  
Only lock nut is loosened to change the main relief valve setting, which could result in the degradation in performance or damage.

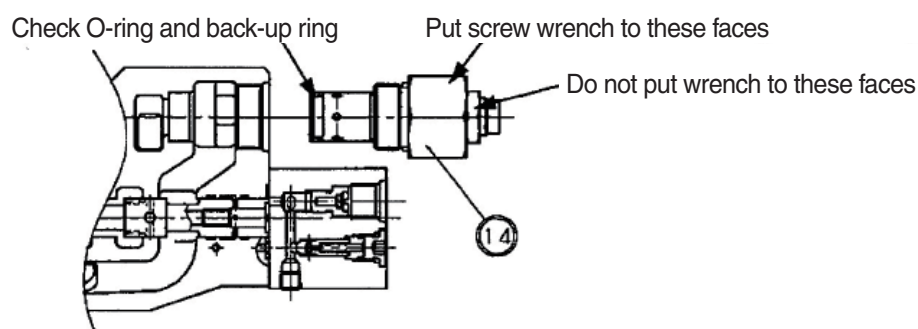

80CR97MCV04

■ Removing relief valve (MRV2, ORV) : see page 2-9

Taking relief valve in the P3 inlet & boom 2 block as an example, the removal procedures are as follows.

- ① Loosen and remove relief valve (15) with 22 mm screw wrench or socket wrench.
  - Put screw wrench (or socket wrench) to 22 mm hexagonal part of pressure regulating body.
  - If there is no 22 mm screw wrench (or socket wrench), it is also possible to loosen and remove by putting 19 mm screw wrench to the hexagonal part as shown in the below.
- ※ If using 19 mm screw wrench to remove, do not put it to the lock nut part.  
Only lock nut is loosened to change the relief valve setting, which could result in the degradation in performance or damage.

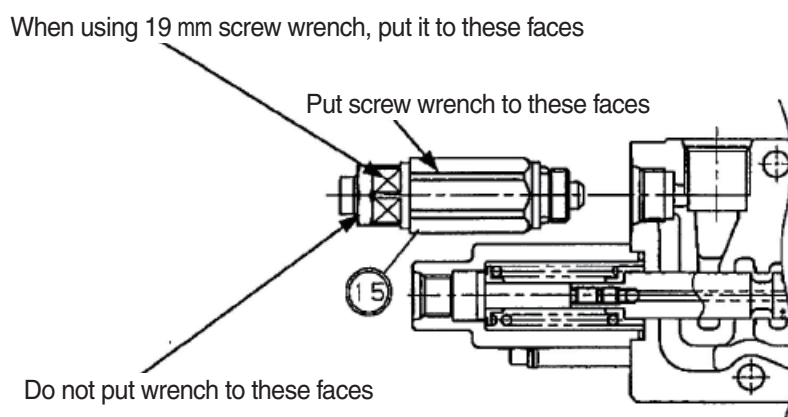

80CR97MCV05

- ※ Removing accessory valve causes the seat to be exposed.  
Flaws of the seat causes leakage from the inside cylinder port, which makes the holding capacity of attachment worse.  
When storing it, be careful not to damage the seat.



#### (4) Block disassembly procedures

- ① Loosen and remove hexagonal socket head bolt (21) assembled in the body QH with 5 mm hexagonal wrench.
  - ② Loosen and remove 8 M8 hexagonal nut (24) for assembling block on the both side of control valve with 13 mm screw wrench or socket wrench.
  - ③ When 8 tie bolt (22, 23) are loosen and pulled out from the control valve side, each block can be removed.
- Be careful not to drop or lose various O-ring (19, 20, 25) installed on the matching surfaces for each block.
  - Do not disassemble 2 plugs installed in the body SG except in cases of absolute necessity since they are used as drill holes for making passages.

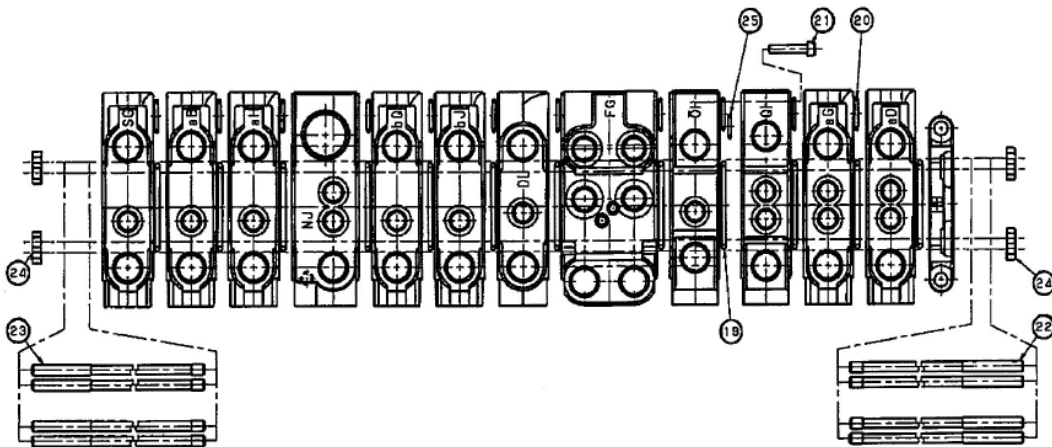

80CR97MCV06

#### (5) Precautions after disassembly

- ※ For the parts already removed in the work, store and/or transport them with attention on flaws and dirt.
- When carrying out another work, storage, or transportation with the parts removed condition, apply caps or plastic tape to the holes from which the parts have been taken out, protecting the holes from being entered with dust or the like.

## 4. ASSEMBLY

### 1) PRECAUTIONS FOR ASSEMBLY

- (1) Be careful that the unevenness of fastening torque and the contamination of dust during assembly work could result in malfunction.  
In addition, observe fastening torque values specified in the specifications and drawings.
- (2) During assembly work, compare valves with control valve structural drawing and check the number of parts whether there is any improper assembly and/or the omission of parts.
- (3) For the parts to be used in assembly, dip in fluid oil as need arises to reassemble after washing well in washing oil and being dried.
- (4) After cleaning and degreasing the surface sufficiently, apply loctite to 2 threads of the screw from the tip. (Too much loctite could result in malfunction after squeezing out)
- (5) For the part to be attached or assembled with two or more bolts and nuts, fastening them evenly and alternately for several times, not once with the specified torque.  
The unevenness of fastening torque could result in the leakage of hydraulic fluid too the outside and/or malfunctions.

### 2) PRECAUTIONS FOR ASSEMBLING SEAL PARTS

- (1) All seals are to be renewed at assembly.
- (2) Check seals for defects in molding and flaws in handling.  
Do not use the seal with defect and/or flaw.
- (3) The seals used on sliding surfaces and the places to be installed with seals are to be applied with grease or hydraulic fluid for sufficient lubrication where not specially noted.
- (4) Do not make seals longer up to permanent deformation.
- (5) O-ring is not to be twisted during assembly.  
Kinked O-ring could cause oil leakage after installation because kinks are hard to restored.

### 3) NECESSARY TOOLS AND OTHERS

Before assembling the control valve, prepare the following tools.

The tools below are used to assemble this control valve only; tools for assembling the port fittings are not included.

Name of tool	Quantity	Size (mm)
Hexagonal wrench	Each 1	4, 5, 6, 8 and 10
Screw wrench	Each 1	13, 19, 21, 22 and 30
Socket wrench	Each 1	13, 19, 21, 22 and 30
Torque wrench	1	0.2 ~ 2.0 kgf · m (1.4 ~ 14.5 lbf · ft)
Torque wrench	1	2.0 ~ 12.0 kgf · m (14.5 ~ 86.8 lbf · ft)
Magnet	1	-
Pliers	1	-
Slotted screwdriver	1	-
Tweezers	1	-

Prepare clean wash oil, hydraulic fluid, grease, loctite #242 and others before work.

#### 4) ASSEMBLING WORK

- ※ The numbers in ( ) in the explanation and in ○ in the figures show reference numbers in the parts table in the specifications and drawings.
- ※ For the fastening torque values for screws, see the 2-9 and 7-43~46.

##### (1) Assembling block (see figure 10 and 11)

- ① On a surface plate with clean rubber plates on it, place blocks with actuator port surface facing upward in the order shown in "Orders of assembling bodies" on the next page.
  - ※ Check the matching surfaces in each block for dust or the like, and check whether O-ring shown in the specifications and drawings are surely put in each groove for O-ring.  
Kinked O-ring could cause the leakage of hydraulic fluid to the outside due to the malfunction of sealing performance.  
If O-ring are not installed surely in O-ring grooves, there would be the nip of O-ring, resulting in the leakage of hydraulic fluid to the outside when assembling the bodies.
- ② Put and fasten 8 tie bolt (②, ③) through the bodies from the side of control valve, and fasten 8 M8 hexagon nut (④) to the bolts **by hand**.
- ③ Check that all the body surfaces are in alignment in this condition.  
If not, make all the body surfaces in alignment by hitting them with plastic hammers or the like.  
Before aligning the bottom surfaces, remove the rubber plates and others that have been laid at ①.  
However, check that there is no dust or no unevenness on the surface from which the above rubber plates have been removed.
  - ※ Do not hit hard when using a plastic hammer.  
Hard hitting could cause displacements in the portion that has been aligned.  
Check the alignment with a flat plate or the like after aligning.  
If there is large displacement in any block, bad connection between internal passages could cause a malfunction.  
If any seal position overlaps the passage, there could be the leakage of hydraulic fluid to the outside.
- ④ After checking that the surfaces are in alignment, fasten 8 M8 hexagon nut (④) that have been put on in ② with the torque specified in the specifications and drawings with 13 mm socket wrench.
  - ※ Fasten 8 M8 hexagon nut evenly and little by little in several times.  
Uneven fastening makes the body assy curve easily, which could result in leakage or malfunction after installation on the machine.  
If you find any curve in the body assy, it is necessary to reassemble or to correct it by pressing machine or the like.
- ⑤ Finally, fasten hex socket head bolt (⑤) located between the body QH and body OH with a specified torque with 5 mm hexagonal wrench.

### Orders of assembling blocks

No.	1	2	3	4	5	6	7	8	9	10	11	12	13
ID	SG	aB	aH	NJ	bQ	bJ	DL	FG	OH	QH	aG	aD	HB

※ Identifications (ID) are engraved on the top (actuator port side) of the block.

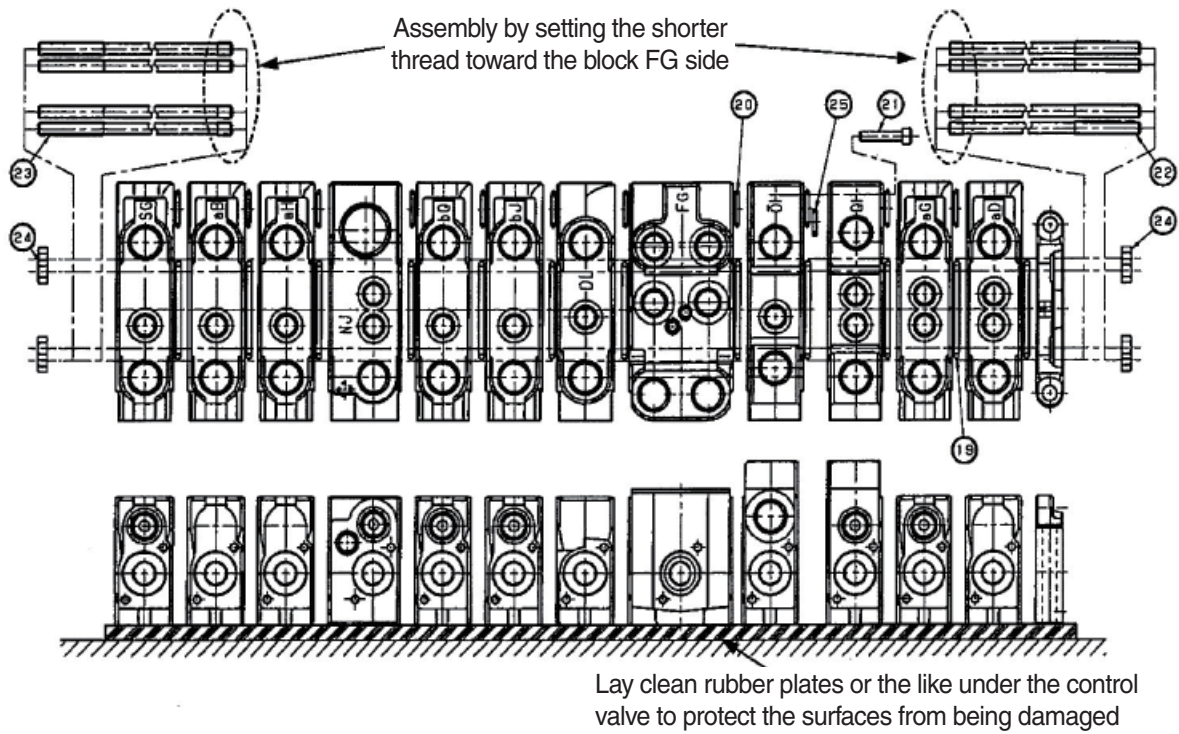

Figure 10. Block assy

80CR97MCV07

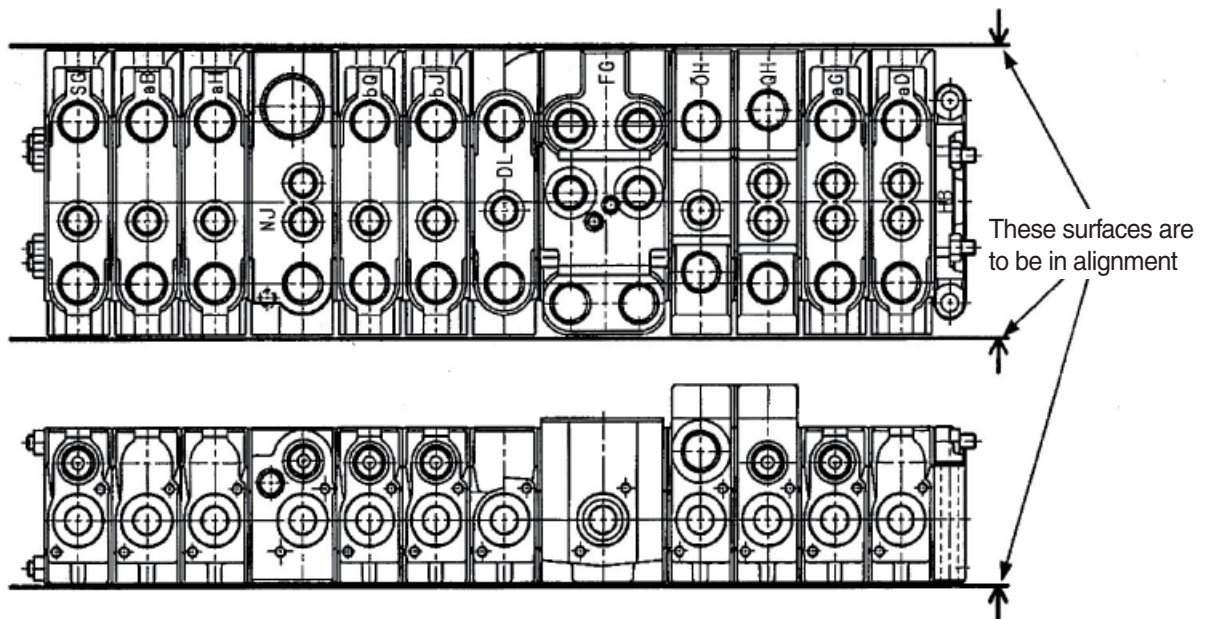

Figure 11. Block assy (after assembly)

80CR97MCV08

## (2) Accessory valve installing procedures

※ Accessory valves are the most important parts for performance and safety; in particular, the relief valve is very difficult to readjust the setting so that replace in assy if any malfunction occurs.

### ■ Installing main relief valve (MRV1) : see page 2-9 and 7-44

- ① Fasten main relief valve (14) with specified torque with 30 mm screw wrench (or socket wrench).
  - Put screw wrench (or socket wrench) to 30 mm hexagonal part of pressure regulating body.
  - Check O-ring and back-up ring are on the part of main relief valve seat.

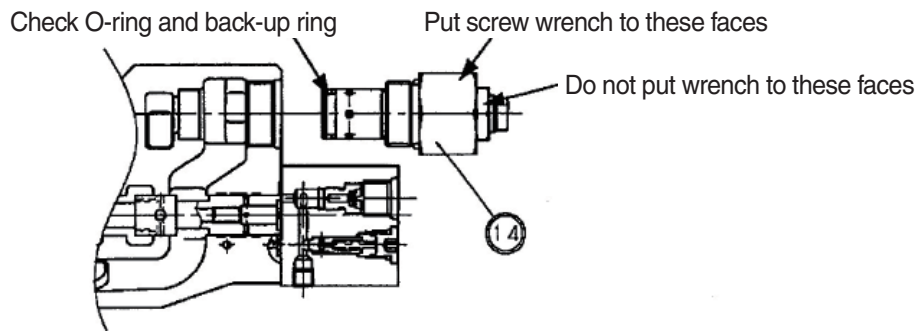

80CR97MCV09

■ **Installing relief valve (MRV2, ORV) : see page 2-9**

- ① Fasten relief valve (15) with specified torque with 22 mm screw wrench (or socket wrench).
- Put screw wrench (or socket wrench) to 22 mm hexagonal part of pressure regulating body.
  - If there is no 22 mm screw wrench (or socket wrench), it is also possible to fasten with 19 mm screw wrench to the hexagonal part as shown in the below.

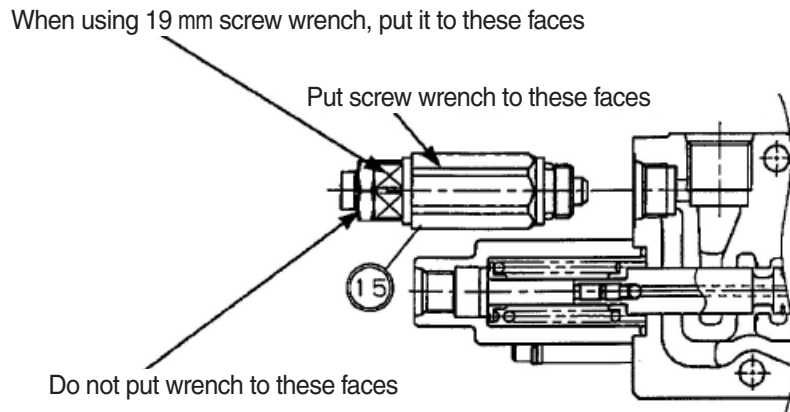

80CR97MCV10

- ※ Be careful not to damage the seat of socket that sticks out above the tip when installing relief valve to the body.
- If the seat is damaged, there could be internal leakage, resulting in the malfunction of holding attachment.
- Do not put 19 mm screw wrench to the lock nut part when installing.
- Lock nut turns with adjustable screw free turning, resulting in the degradation in performance or damage.



### (3) Check valve assembly procedures

#### ■ Standard type check valve (see figure 14)

- ① Hold the control valve body at workbench or hold it by two or more people.
  - ② Assemble check valve (7) and check valve spring (8) in sequence at the center of control valve top surface.  
Then, set check valve (7) vertically. (Check that the check valve is in nearly at the center of hole)
  - ③ Check that O-ring (10) is securely installed with check valve plug (9) and then screw it into the part where check valve has been assembled.
  - ④ Fasten check valve plug (9) with specified torque with 8 mm hexagonal wrench.
- The other check valves can be assembled in the same manner, use suitable parts in the drawing. (see figure 15 and 16)
- If assembly is mistaken, check valve could not function or there could be damage.

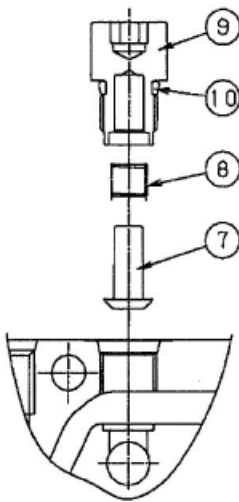

Figure 14. Check valve  
(P1, P2 inlet & straight travel)

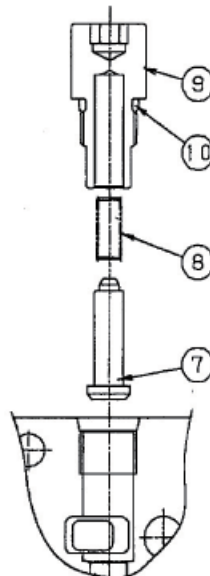

Figure 15. Check valve  
(P3 inlet & boom 2, travel)

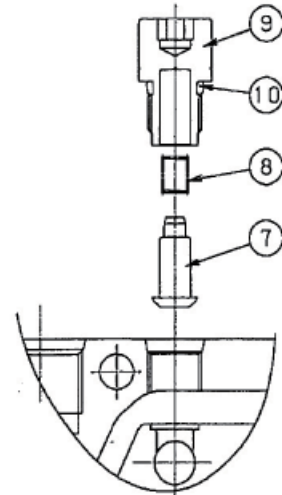

Figure 16. Check valve  
(Swing & boom swing, dozer,  
arm 3 & boom 3, service, arm,  
boom, bucket, arm 2)

80CR97MCV11

#### (4) Spool installing procedures

##### ■ Except P1, P2 inlet & straight travel block

Taking the dozer spool as an example, the installing procedures are as follows.

- ① After checking whether there is no dust or the like in the spool sleeves of the body and/or spool assy and O-ring (③) is securely installed with that the flange bottom of the body, insert the dozer spool assy into spool sleeve of the body with attention on the position and direction.
    - Then, apply little hydraulic fluid to spool before the insertion.
  - ※ Carefully insert spool assy into the spool sleeve horizontally.
    - If it is hard to insert, forcible insertion could cause impressions on spool sleeves and/or spools, resulting in malfunction.
    - If you feel any feeling of wrongness such as catches or strong resistance, pull it out once to check whether there is the adhesion of dust or the development of flaw or burr.
    - If there are flaws or burrs, there could be malfunction so that replace body and spool in set.
  - When there is no feeling of wrongness, move it slowly several times to check the movement and no feeling of wrongness again.
- ② Press pilot cover (④) in a direction from the spring side of spool assy to the flange of the body.  
Fasten 2 hex socket head bolt with washer (⑥) with specified torque with 5 mm hexagonal wrench.
  - ③ The other spools can be assembled in the same manner.

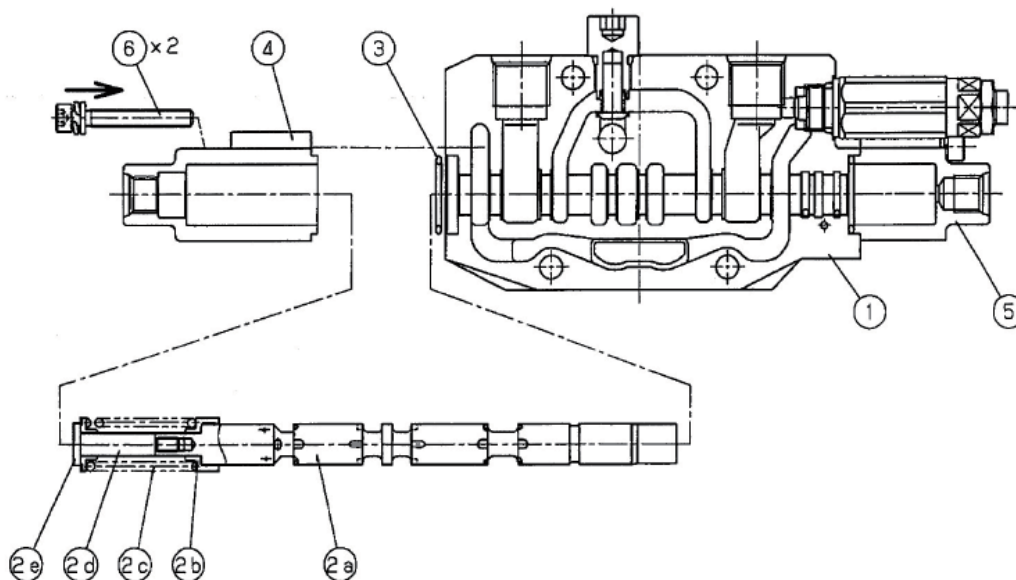

80CR97MCV12

### ■ P1, P2 inlet & straight travel block

The installing procedures for the straight travel spool is as follows.

- ① Assemble spring seat (9) and spring (10) at the end of spool.
- ② After checking whether there is no dust or the like in the spool sleeves of the body any/or spool and O-ring (3) is securely installed with that the flange bottom of the body, insert the straight travel spool with spring into spool sleeves of the body with attention on the position and direction.
  - Then, apply little hydraulic fluid to spool before the insertion.

#### ▲ Carefully insert the straight travel spool into the spool sleeve horizontally.

If it is hard to insert, forcible insertion could cause impressions on spool sleeves and/or spools, resulting in internal leakage.

If you feel any feeling of wrongness such as catches or strong resistance, pull it out once to check whether there is the adhesion of dust or the development of flaw or burr.

If there are flaws or burns, there could be internal leakage so that replace body and spool in set.

- ③ Press pilot cover (11) in a direction from the spring side of spool assy to the flange of the body.  
Fasten 2 hexagon socket head bolt with washer (8) with specified torque with 5 mm hexagonal wrench.

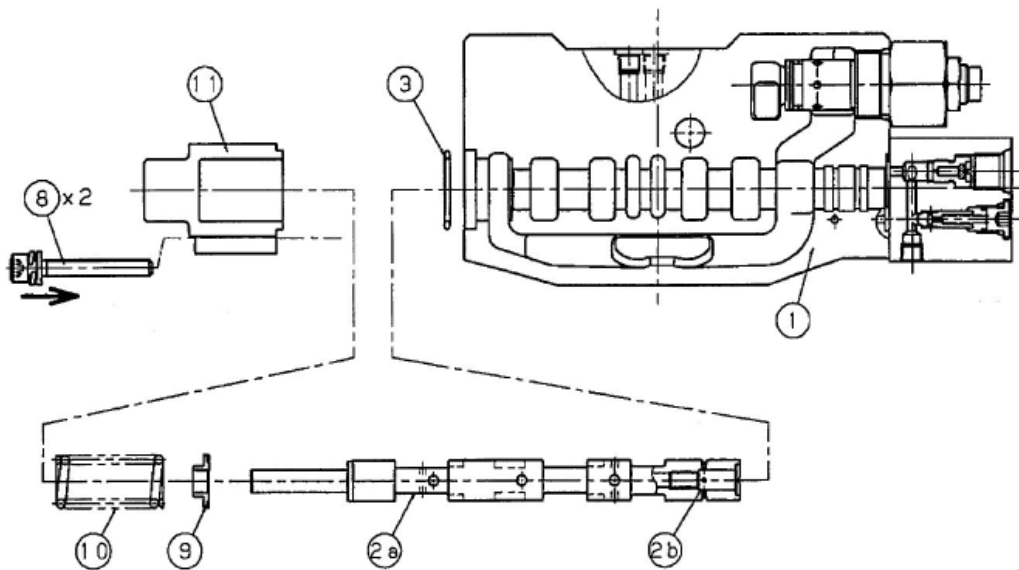

80CR97MCV13

## 5. MAINTENANCE STANDARD

### 1) PARTS CHECK

Name	Inspection item	Criterion and treatment
Work body	Presence of scratch, rust, corrosion	Replace it if any of the followings is damaged <ul style="list-style-type: none"> <li>· Sliding parts for spool, especially lands with holding pressure</li> <li>· Body flanges receiving spool</li> <li>· Seal parts contacting with O-ring in ports</li> <li>· Seats in relief and overload relief valves</li> <li>· Damage spoiling normal functions</li> </ul>
Spool	Presence of scratch, scuff, rust, corrosion Insert spool into body and stroke it with turning	Replace it if scratch is on outer sliding part Replace or correct it if spool does not move smoothly
Check valve (Load check valve)	Damage to check valve or check valve spring Insert check valve into check valve plug to operate	Replace or correct it if flaw or dent is on seat Smooth moving without scratch is normal Replace it if not
Spring and related parts	Rust, corrosion, deformation, breakage in return spring seat, plug, cover	Replace it if there is non-smooth operation or heavy damage
Sealing of spools	Hardened, deformed, or damaged O-ring	Replace it
Relief valve	Rust in appearance Matching surface of valve seat Abnormality in spring O-ring, back-up ring	Replace it Replace it if there is flaw or dent Replace it 100% replacement in principle

## 6. PROBLEM CAUSES AND MEASURES

- ※ If any abnormal condition is found, check whether control valve itself fails or there is problem in pump, cylinder, motor, or hydraulic circuit. For this check, it is necessary to measure pilot pressure, pump discharge pressure, and load pressure. Observe the above disassembly and assembly procedures even if any part is disassembled or inspected.
- ※ Be careful of dust proofing. Dust is very harmful to hydraulic devices.
- ※ Carefully handle moving movable parts. Correct it with oilstone or replace it even if there is a minor flaw. Clean it sufficiently after correction.
- ※ Protect the seal surface of O-ring from being damaged. The damage could cause oil leakage.

### 1) CONTROL VALVE

Phenomenon	Possible causes	Treatment
No movement in each attachment. Slow operation (Power shortage) or slow response	Operation failure in relief valve <ul style="list-style-type: none"> <li>· Dust between regulating valve and seat★</li> <li>· Dust between regulating valve seats★</li> <li>· Stick of regulating valve★</li> <li>· Breakage or fatigue of spring★</li> <li>· Loosened adjustable screw</li> </ul> Dust between body and spool, or stick	Measure relief valve pressure <ul style="list-style-type: none"> <li>· Replacement in assy★</li> <li>· Replacement in assy★</li> <li>· Replacement in assy★</li> <li>· Replacement in assy★</li> <li>· Readjust and fasten lock nut with specified torque</li> <li>· Disassemble and clean it</li> </ul> Replace body and spool if damage is big
Cylinder's empty weight falling in neutral is big	Excessive gap between block and spool Spool is not returned to neutral completely <ul style="list-style-type: none"> <li>· Dust storage between body and spool, or stick</li> <li>· Breakage or fatigue of spring</li> </ul> Operation failure in relief valve (ORV) (see 5. Maintenance standard) Operation failure in lock valve <ul style="list-style-type: none"> <li>· Dust between lock valves or needle valve seats</li> <li>· Stick of lock valve or needle valve</li> <li>· Orifice clogging in lock valve</li> </ul>	Replace spool Measure pilot secondary pressure <ul style="list-style-type: none"> <li>· Disassemble and clean, or replace body and spool in set for stick</li> <li>· Replace spring</li> </ul> Measure relief valve pressure (ORV) (see 5. Maintenance standard) Replace lock valve assy (including lock valve body)
When operating to rise cylinder at starting operation, it lowers	Operation failure in load check valve <ul style="list-style-type: none"> <li>· Dust between load check valve and body</li> <li>· Stick in load check valve</li> <li>· Breakage or fatigue of spring</li> </ul>	<ul style="list-style-type: none"> <li>· Disassemble and clean</li> <li>· Replace body and load check valve if damage is big</li> <li>· Disassemble and clean</li> <li>· Replace body and load check valve if damage is big</li> <li>· Replace spring</li> </ul>

For problem with ★ mark, must replace relief valve in assy.

## 2) RELIEF VALVE

Relief valve is the most important part for performance and safety, and is very difficult to readjust the setting at a place except maintenance shops with adequate equipment.

Replace in assy if any of the following malfunctions occurs.

Treatments here are only for reference, and the replacement in assy is in principle.

Phenomenon	Possible causes	Treatment
Pressure cannot rise	Any pressure regulating valve, regulating valve, or piston in relief valves has stuck to keep opening, or dust presents on any seat in relief valves	<ul style="list-style-type: none"> <li>· Check whether foreign matter has been stored in matching parts in relief valves</li> <li>· Each part is to be slid freely</li> <li>· Clean all parts completely</li> </ul>
Relief pressure is unstable	Each regulating valve in relief valves is damaged  Piston has stuck in pressure regulating valve	<ul style="list-style-type: none"> <li>· Replace damaged parts</li> <li>· Clean all parts completely</li> <li>· Remove flaws from surface</li> </ul>
Relief pressure is out of setting range	Attrition by dust Lock nut and adjustable screw are loosened Breakage or fatigue of spring Operation failure in relief valve (MRV and ORV)	Disassemble and clean  Regurate pressure  Replace spring  Measure pressures of relief valve (MRV and ORV)
Oil leakage	Damage in each seat Attrition in O-ring  Stick of each part due to dust	Replace damaged or attrition part Check each part moves smoothly, and reassemble  Check that there is no scratch, dent, or foreign matter, and reassemble



## GROUP 5 SWING DEVICE

### ■ TYPE 1

#### 1. REMOVAL AND INSTALL OF MOTOR

##### 1) REMOVAL

- (1) Lower the work equipment to the ground and stop the engine.
- (2) Operate the control levers and pedals several times to release the remaining pressure in the hydraulic piping.
- (3) Loosen the breather slowly to release the pressure inside the hydraulic tank.

#### ▲ Escaping fluid under pressure can penetrate the skin causing serious injury.

※ When pipes and hoses are disconnected, the oil inside the piping will flow out, so catch it in oil pan.

- (4) Disconnect hose assembly (2, 3).
- (5) Disconnect pilot line hoses (4, 5, 6, 7, 8).
- (6) Sling the swing motor assembly (1) and remove the swing motor mounting bolts (9).

※ Motor device weight : 23 kg (51 lb)

- (7) Remove the swing motor assembly.  
※ When removing the swing motor assembly, check that all the piping have been disconnected.

##### 2) INSTALL

- (1) Carry out installation in the reverse order to removal.
- (2) Bleed the air from the swing motor.
  - ① Remove the air vent plug.
  - ② Pour in hydraulic oil until it overflows from the port.
  - ③ Tighten plug lightly.
  - ④ Start the engine, run at low idling and check oil come out from plug.
  - ⑤ Tighten plug fully.
- (3) Confirm the hydraulic oil level and check the hydraulic oil leak or not.

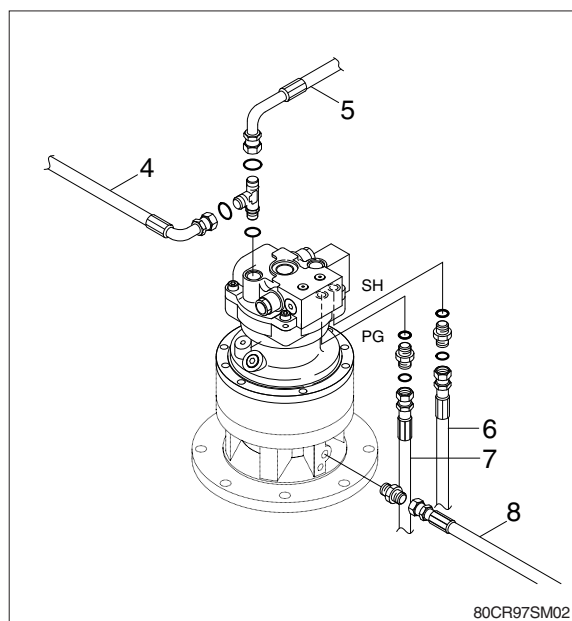
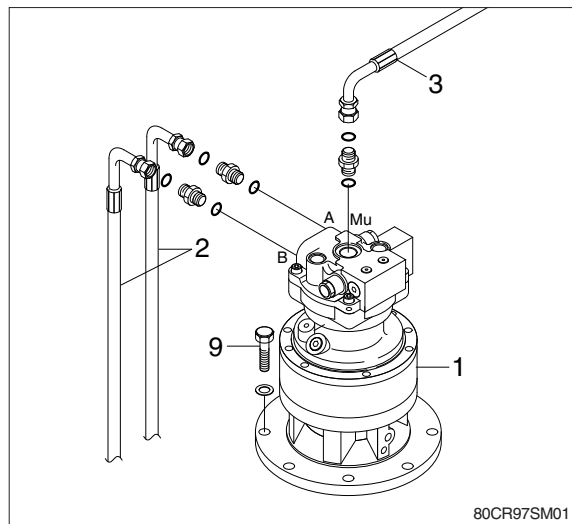

## 2. DISASSEMBLY AND ASSEMBLY OF SWING MOTOR

### 1) STRUCTURE

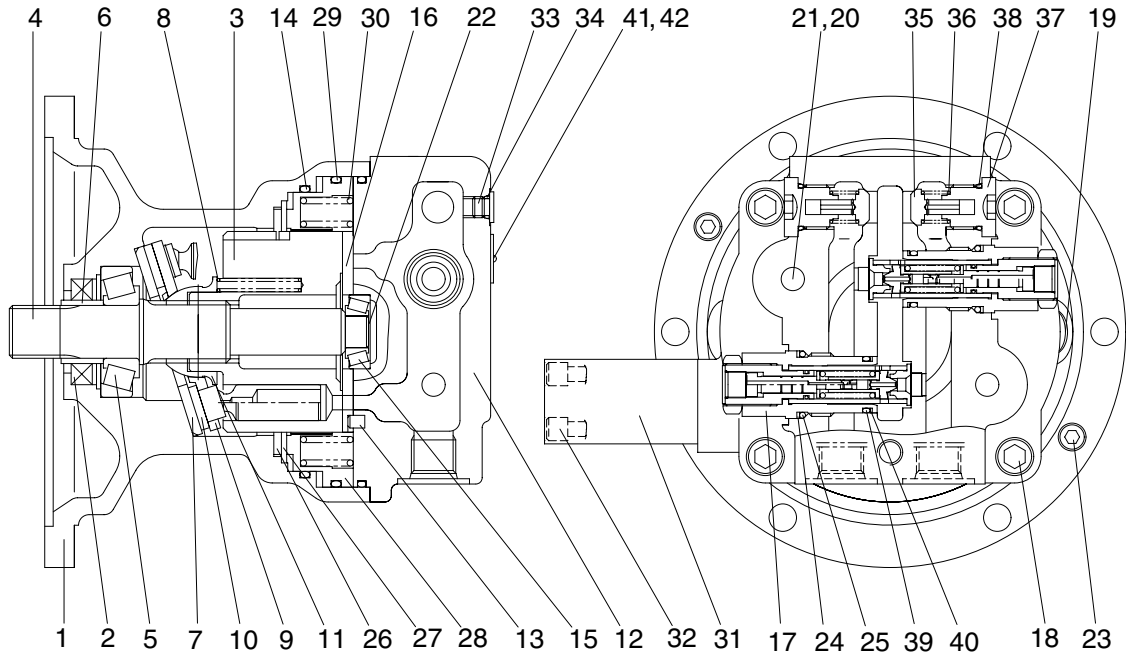

7072SM01

1	Body	15	Taper bearing	29	O-ring
2	Oil seal	16	Valve plate	30	Spring
3	Cylinder block	17	Relief valve assy	31	Time delay valve
4	Shaft	18	Socket bolt	32	Socket bolt
5	Taper bearing	19	Plug	33	Plug
6	Bushing	20	Plug	34	O-ring
7	Shoe plate	21	O-ring	35	Valve
8	Spring	22	Shim	36	Spring
9	Set plate	23	Plug	37	Plug
10	Piston shoe assy	24	Back up ring	38	O-ring
11	Ball guide	25	O-ring	39	O-ring
12	Rear cover	26	Friction plate	40	Back up ring
13	Pin	27	Plate	41	Name plate
14	O-ring	28	Parking piston	42	Rivet

## 2) DISASSEMBLY

- (1) Removal of relief valve assembly  
Remove cap of relief valve assembly (17) with 14 mm hexagonal wrench.  
※ Assemble removed relief valve assembly (17) to original state when reassembling.

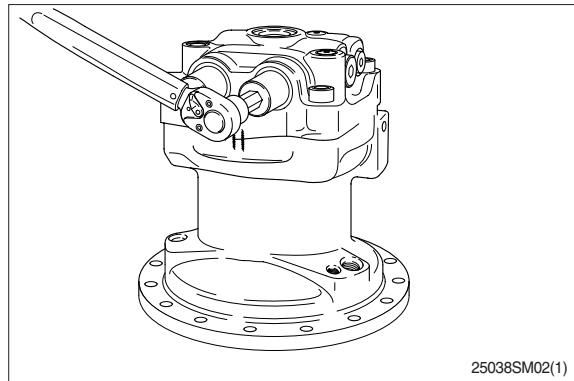

- (2) Removal of make up valve and bypass valve assembly  
Loosen plug (37) with 14 mm hexagonal wrench, and remove check valve (35) and spring (36).

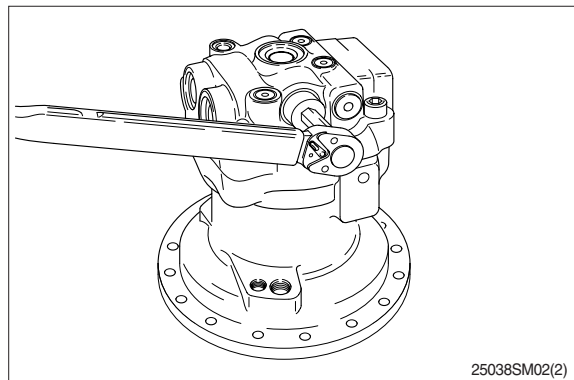

- (3) Marking at swing motor  
Before disassembling motor, make a matching mark between cover (12) and housing (1) for easy reassembling.

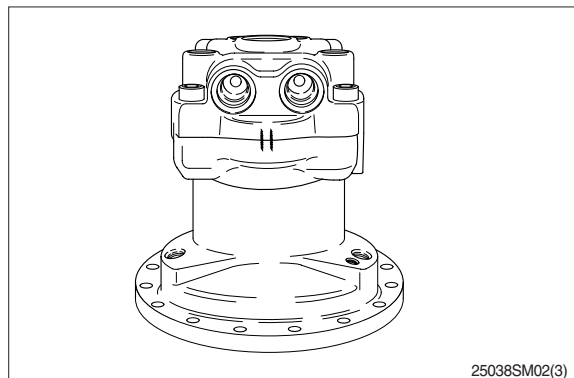

- (4) Remove mounting bolts of cover  
Loosen hexagon socket bolt (18) with 12 mm hexagonal wrench.

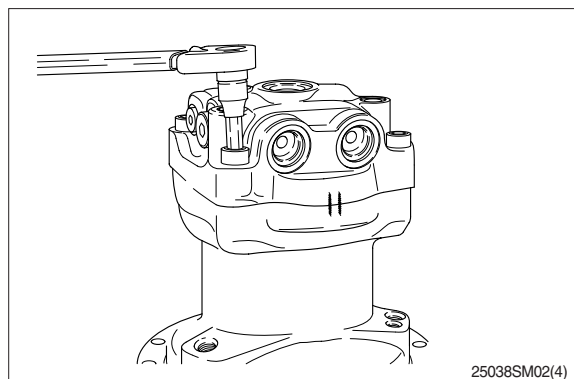

- (5) Removal of cover assembly  
Place shaft of motor assembly to downward and take cover (12) out.

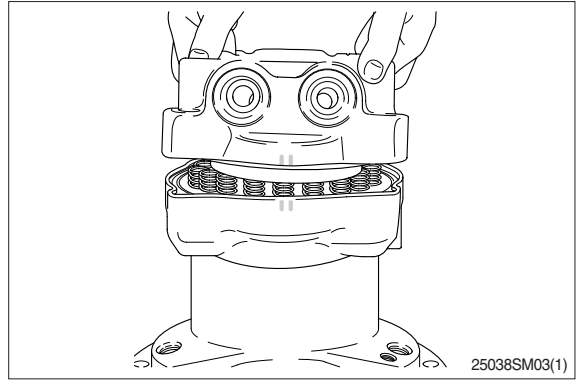

- (6) Remove shim (22) remove inner race of needle bearing (15) by bearing puller.

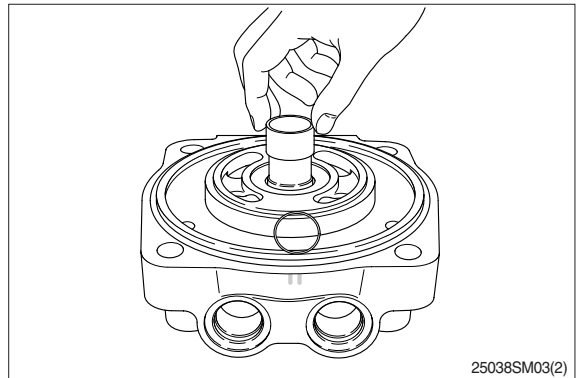

- (7) Remove O-ring (29) from cover.

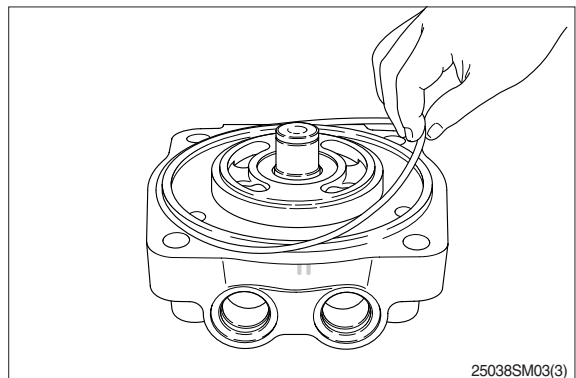

- (8) Remove balance plate  
Valve plate (16) is adhered on end surface of cylinder (3) by oil viscosity. Take off balance plate (16) with hands.  
Assembling method of balance plate (16) depends on cover (12).  
(Band groove and round groove of high · low pressure transmission area)  
Before removing, check and record location of balance plate (16) to prevent mis-assembling.

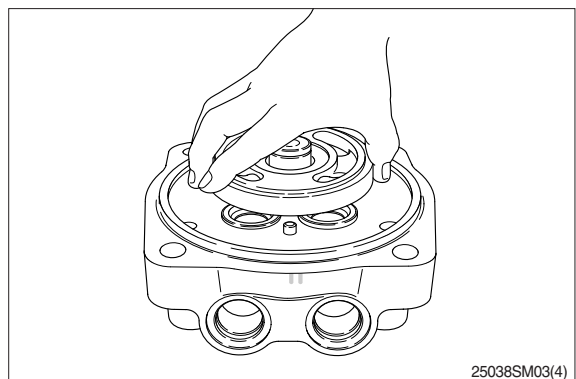

- (9) Removal of spring (30, brake area)  
Remove spring (30) from piston (28).  
Check and record original position of  
each spring (30) for correct assembling.

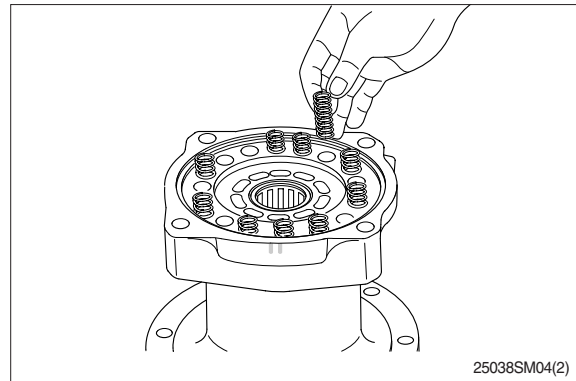

- (10) Removal of brake piston  
When removing piston (28) from housing  
(1), there is a sliding resistance against  
tightening of O-rings (14,29). Use tap  
hole on piston (28) as shown in the pic-  
ture.

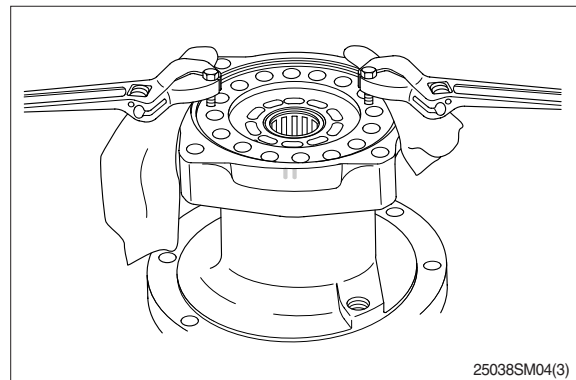

- (11) Remove O-rings (14, 29) from piston (28)  
and housing (1).

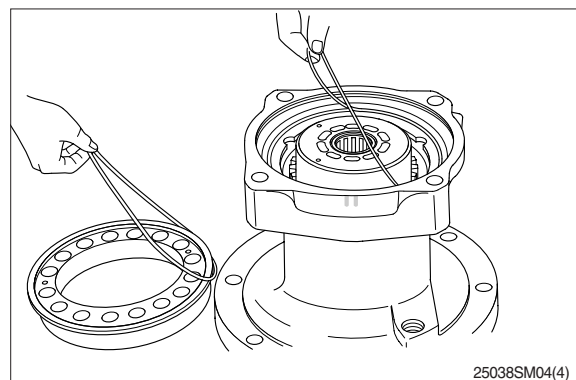

- (12) Remove friction plate (26) and lining plate  
(27) from housing (1).

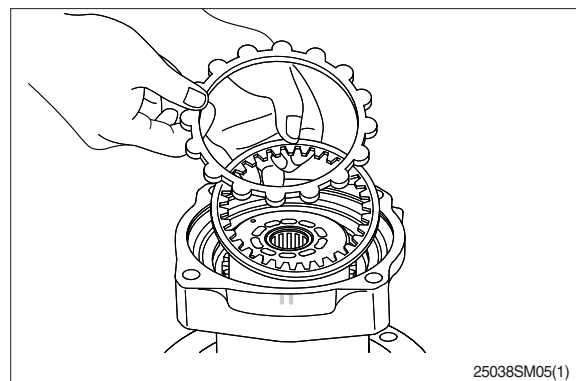

(13) Removal of cylinder assembly

Holding end of cylinder assembly (3) with hand, draw out cylinder assembly from housing.

- ※ Oil seal (2) and outer race of taper roller bearing (15) are left inside of housing.
- ※ End surface of cylinder (3) is sliding face . So, protect the surface with a scrap of cloth against damage.
- ※ Make a matching mark on piston hole of cylinder (3) and piston assembly (10) to fit piston into the same hole when reassembling.

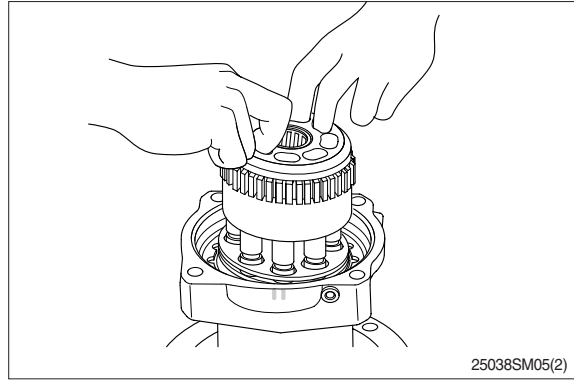

(14) Separate outer race of taper roller bearing (5) from housing.

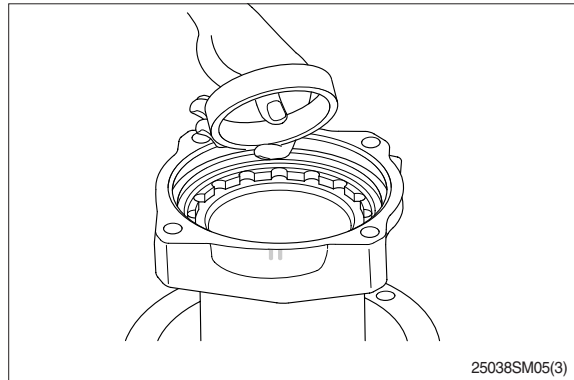

(15) Removal of oil seal

Remove oil seal (2) from housing (1) with driver and hammer.

- ※ **Do not reuse oil seal after removal.**

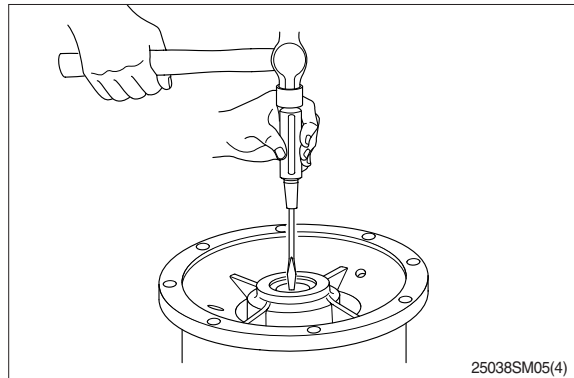



**(16) Disassembly of cylinder assembly**

- ① Removal of inner race of taper roller bearing (5).

Lift out cylinder block (3) with 2 inner race of roller bearing (5) by applying gear puller at the end of spline in the cylinder.

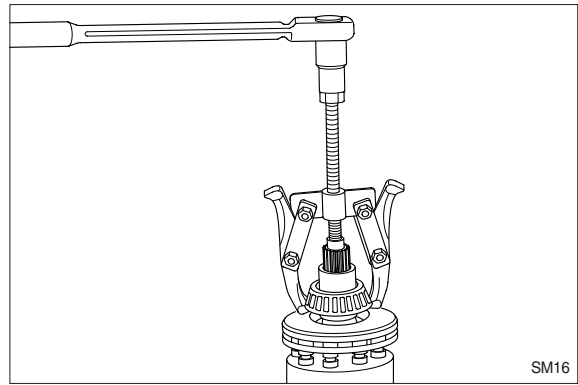

- ② Separate shoe plate (7), piston assembly (10), set plate (9) from cylinder block (3).

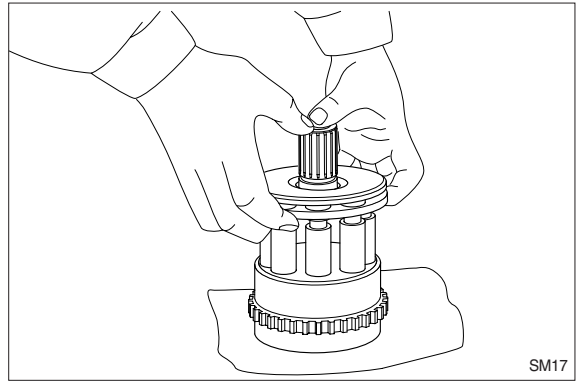

- ③ Get shoe plate (7) slide on sliding face of piston assembly (10) and remove it.

※ Be cautious not to damage on sliding face of cam plate.

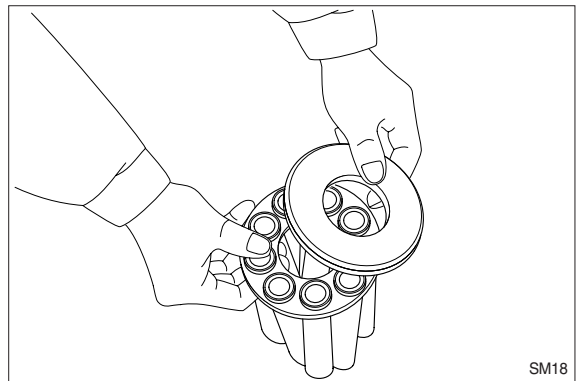

- ④ Remove ball guide (11) from cylinder block (3).

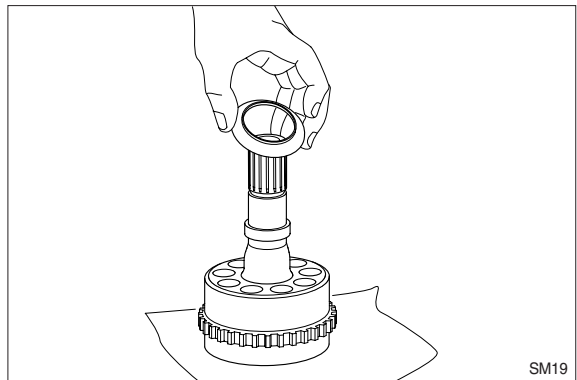

This completes disassembly.

### 3) ASSEMBLY

#### (1) Preparation

Before reassembling, perform below procedure.

- ① Check each part for damage caused by using or disassembling. If damaged, eliminate damage by grinding with proper sandpaper, wash them with cleaning oil and dry with compressed air.
- ② Replace seal with new one.
- ③ Grind sliding face of piston assembly (10), balance plate (16) and shoe plate (7) with sandpaper #2000.

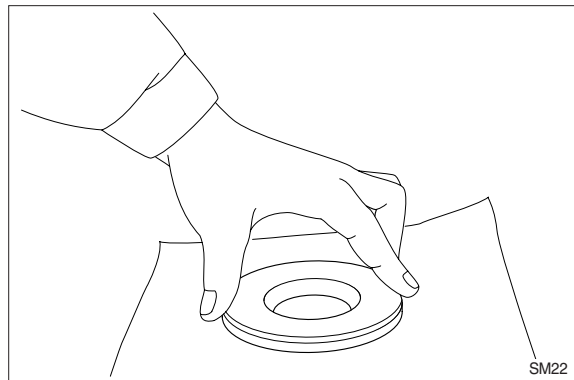
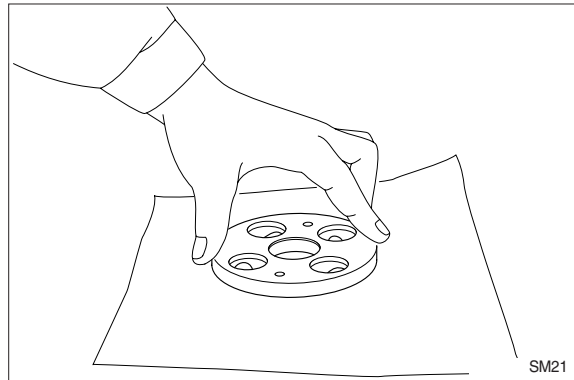
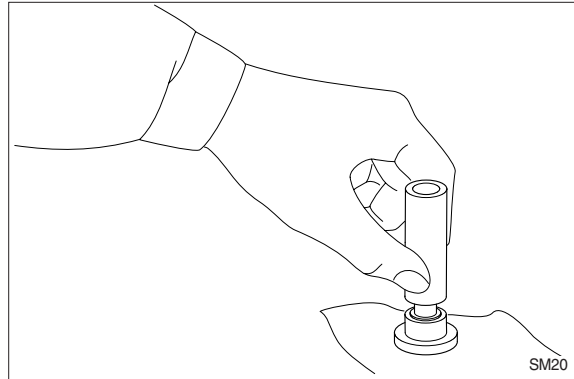

- ④ When assembling, lubricate with specified clean hydraulic oil.
- ⑤ When assembling piston assembly (10) to piston hole of cylinder block (3), check matching mark between them.

## (2) Cylinder assembly

- ① Lubricate grease on round area (Contacting area with ball guide (11)) of cylinder block (3) and assemble spring (4).

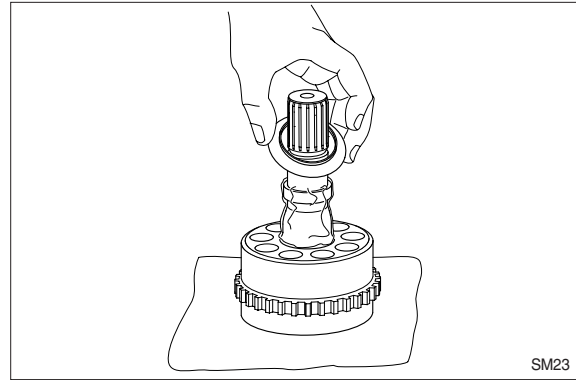

- ② Insert piston assembly (10) in hole of set plate (9).

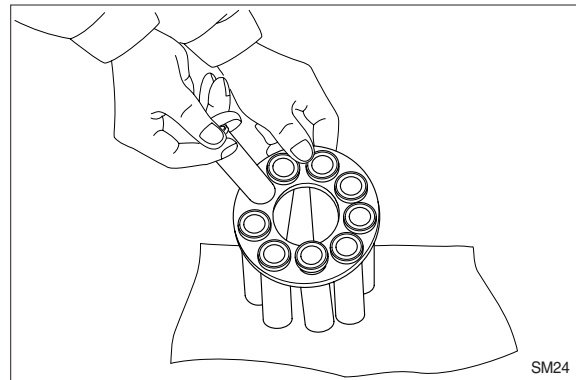

- ③ Assemble piston assembly (10) and set plate (9) to cylinder block (3). When assembling, check matching mark between them. Before assembling, lubricate specified hydraulic oil in piston hole of cylinder block (3).

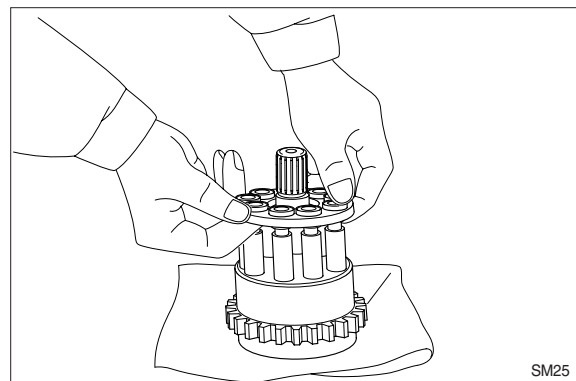

- ④ Lubricate specified hydraulic oil on shoe sliding face of piston assembly (10) and assemble shoe plate (7).

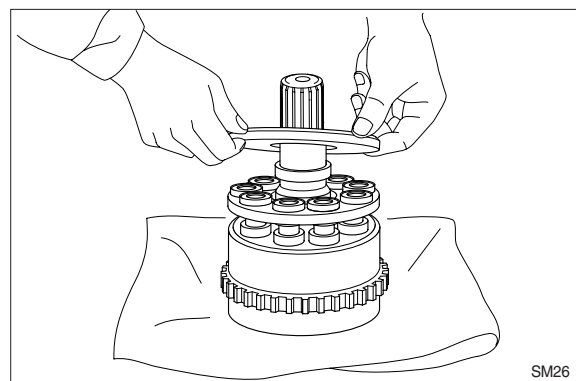

- ⑤ Assemble inner race of taper roller bearing (5) to cylinder block (3).

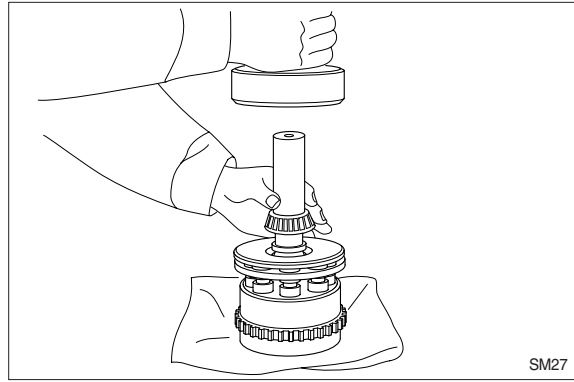

- ⑥ Apply loctite to bearing mounting area of inner race of cylinder block (3) lightly.

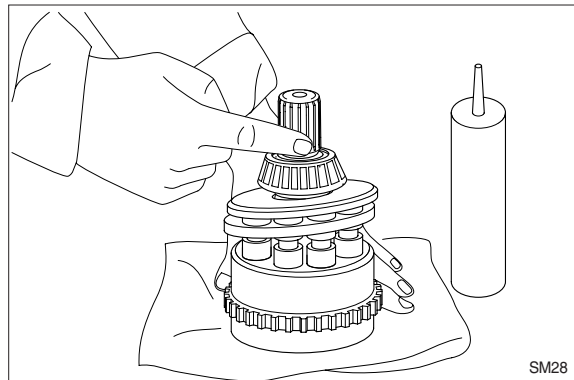

- ⑦ Assemble bushing (6) to cylinder block (3).

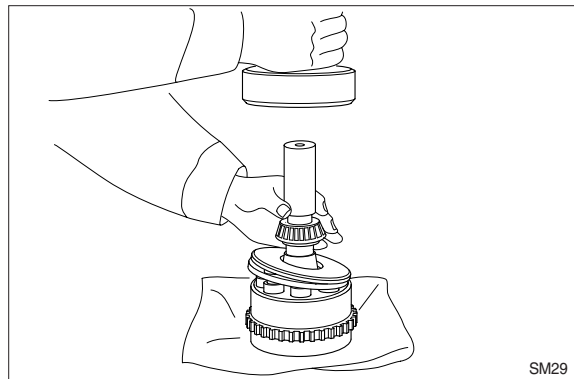

### (3) Oil seal

Apply three bond of white color on outer surface of oil seal (2) and assemble and insert it.

- ※ Before assembling, lubricate lip of oil seal with grease.

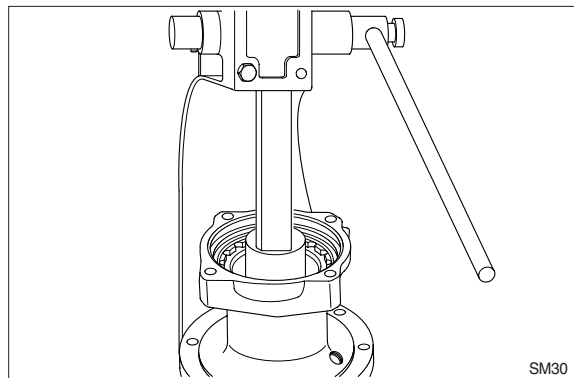

- (4) Assemble outer race of taper roller bearing (5) to motor housing (1).

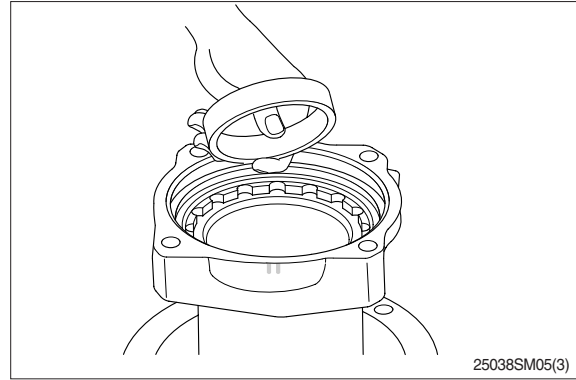

**(5) Cylinder assembly**

Hold end of cylinder assembly(3) with hands and assemble cylinder assembly to housing(1). Be careful to prevent damage of seal by spline of shaft.

- ※ When assemble cylinder assembly, spline shaft of cylinder is protruded from end of housing, therefore put pads with length 30~50mm under bottom of housing.

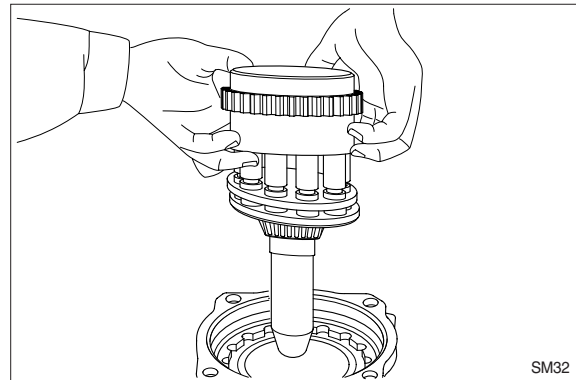

- (6) Assemble friction plate (26) and lining plate (27).

- ※ Lubricate specified hydraulic oil on each side.

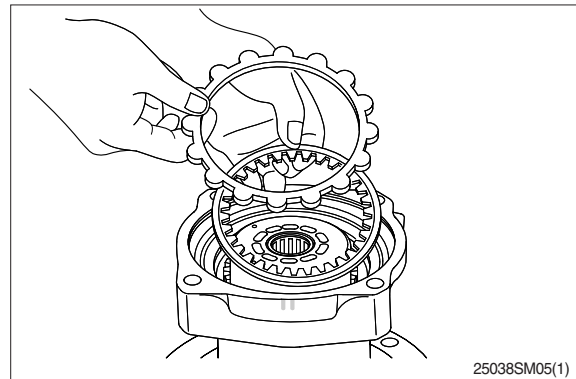

- (7) Insert O-rings (14,29) into housing (1) and piston (28).

- ※ Lubricate O-ring with grease.

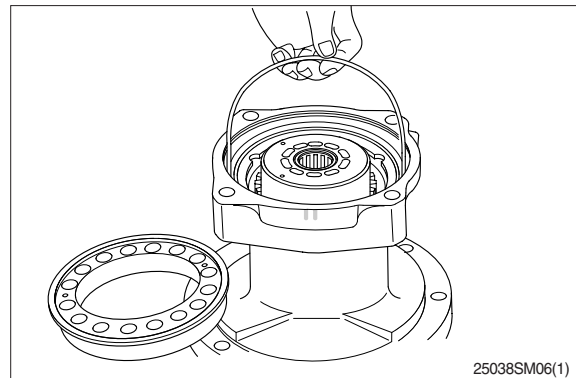

**(8) Brake piston**

Lubricate specified hydraulic oil on outer sliding face of piston (28) and assemble brake piston to housing (1).

- ※ It is too tight to assemble piston (10) because O-rings (14,29) are fitted, therefore it is recommended to push piston (28) horizontally by hands at once.

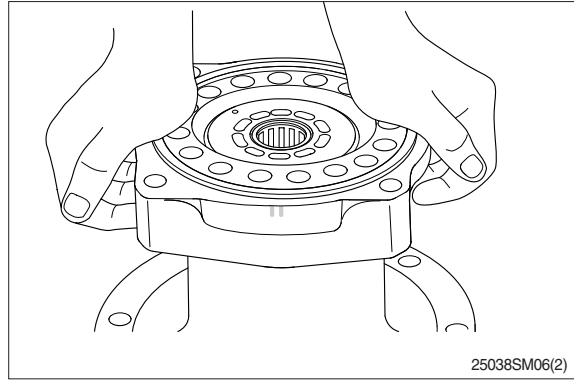

**(9) Spring (30, brake unit)**

Assemble spring (30) to piston (28) of brake unit.

- ※ Insert spring (30) into original position.

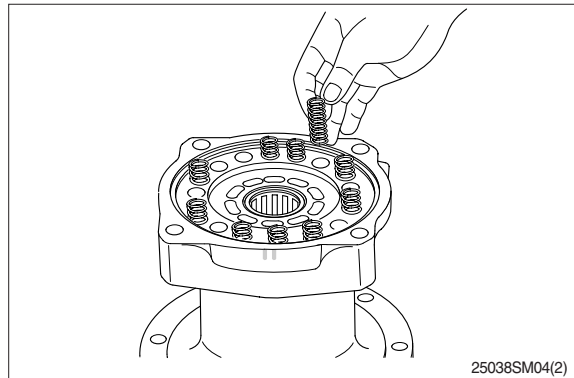

- (10) Lubricate locating pin for antirotation of valve plate (16) of cover (12) with grease sufficiently and install locating pin to housing.

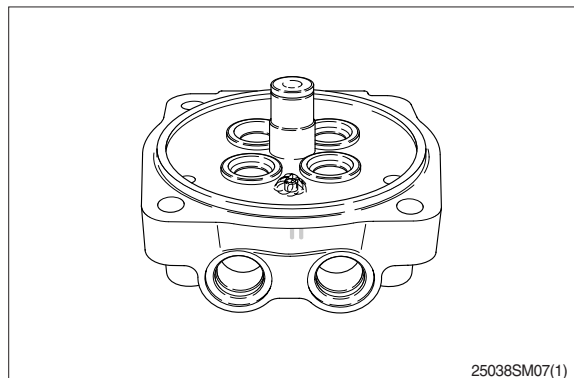

**(11) Balance plate**

Assemble valve plate (16) to cover (12).

- ※ Be cautious of assembling direction.

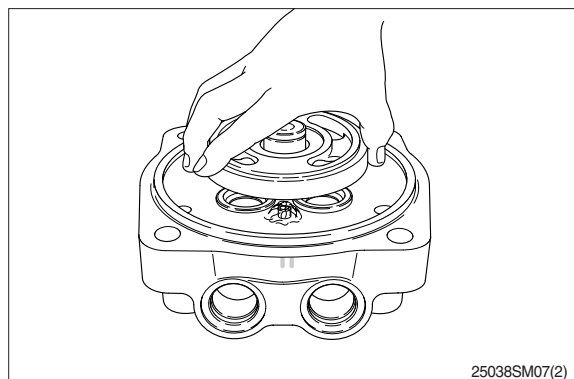



- (12) Assemble inner race of needle bearing (15) and shim (22) to cover (12).

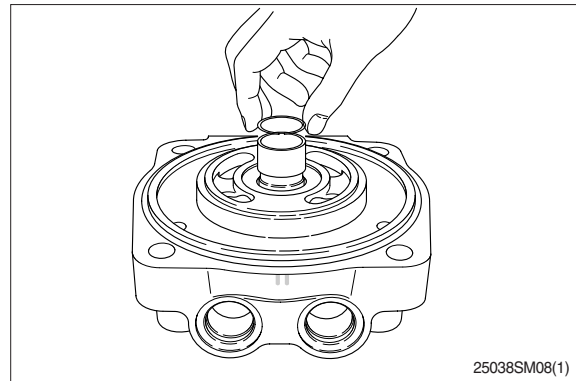

- (13) Assemble O-ring (29) to cover (12).  
※ Lubricate O-ring with grease.

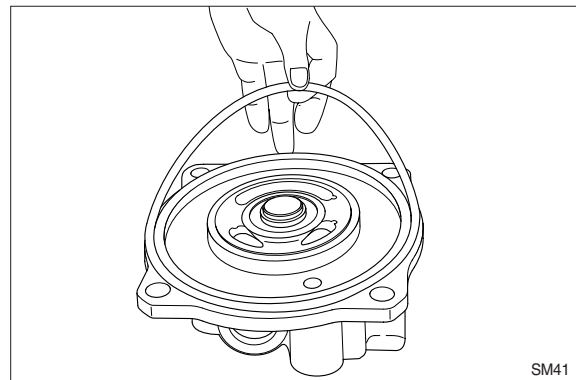

- (14) Apply three bond of white color to distinguish oil leakage from remaining oil in bolt hole of cover (12).

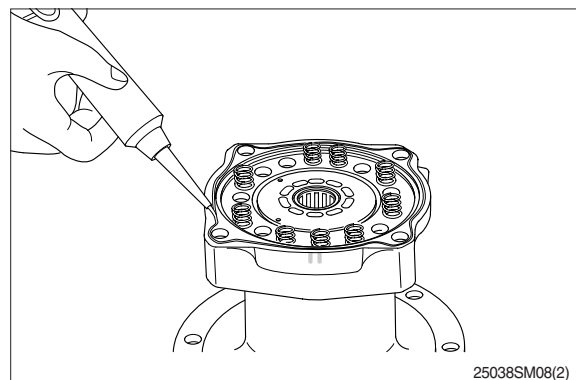

### (15) Cover

- Assemble cover (12) and valve plate (16) to housing (1) lightly, holding them up with hands.
- ※ When assembling, be careful not to detach valve plate (16) and bushing (6) from cover (12).
  - ※ Fit matching marks on housing (1) and cover (12) made before disassembling.

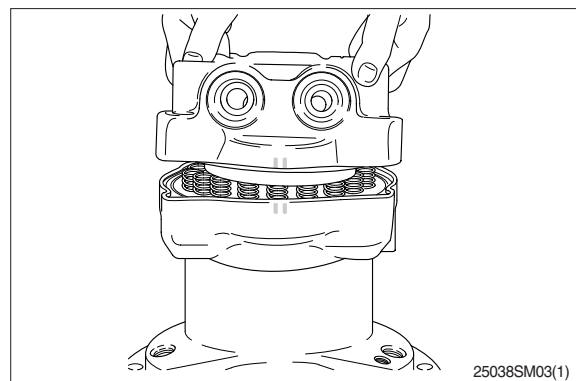

- (16) Tighten cover (12) and housing (1) with 12 mm hexagonal socket bolt (18).  
 · Tightening torque : 16 kgf · m (116 lbf · ft)

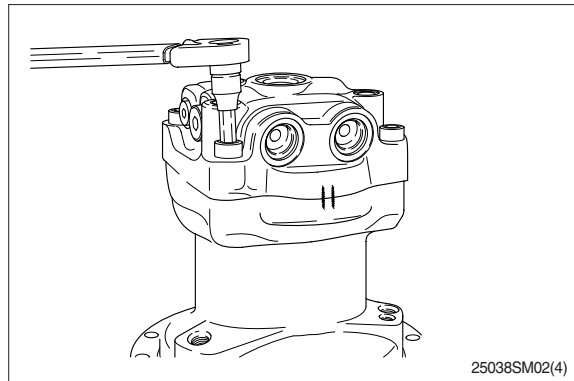

**(17) Make up valve**

- Assemble check(35) and spring(36) to cover(12) and tighten plug(37) with 14 mm hexagonal socket bolt.  
 · Tightening torque : 14 kgf · m (101 lbf · ft)

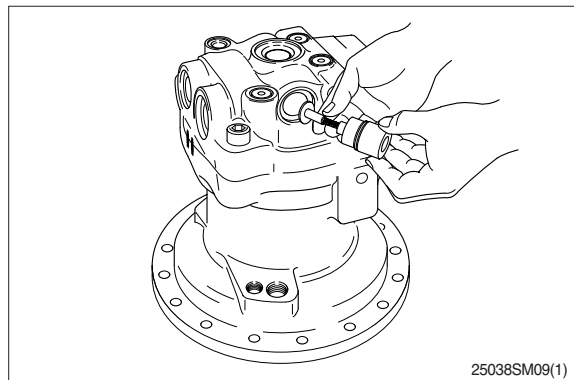

**(18) Relief assembly**

- Assemble relief valve assembly(17) to cover(12) with 14mm hexagonal socket bolt.  
 · Tightening torque : 8 kgf · m (58 lbf · ft)  
 ※ Be cautious of assembling method.

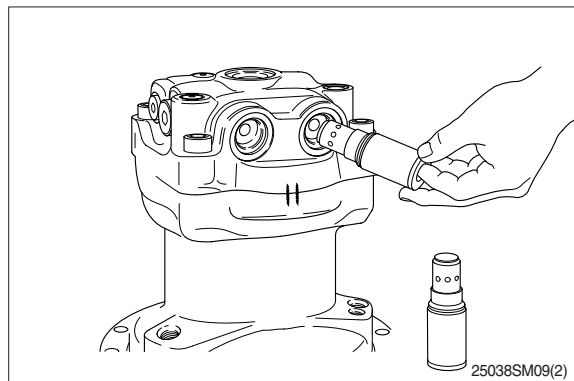

**(19) Check of assembly**

- Load pilot pressure of 20 kgf/cm<sup>2</sup> to brake release port after opening inlet and outlet port.  
 Check if output shaft is rotated smoothly around torque of 0.5~1 kgf · m.  
 If not rotated, disassemble and check.

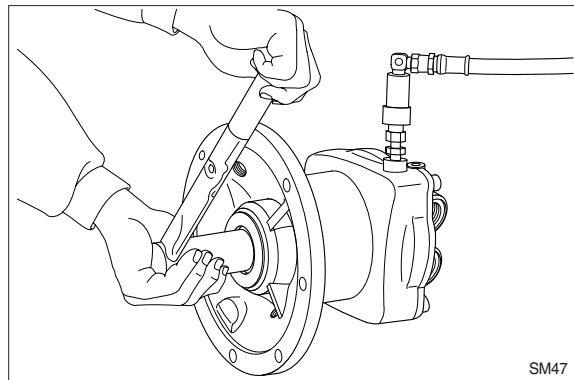

This completes assembly.

### 3. REMOVAL AND INSTALL OF REDUCTION GEAR

#### 1) REMOVAL

- (1) Remove the swing motor assembly.  
For details, see removal of swing motor assembly.
- (2) Sling reduction gear assembly (1) and remove mounting bolts (2).
- (3) Remove the reduction gear assembly.
  - Reduction gear device weight : 45 kg  
(99 lb)



#### 2) INSTALL

- (1) Carry out installation in the reverse order to removal.
  - Tightening torque : 10.5 kgf · m  
(76 lbf · ft)

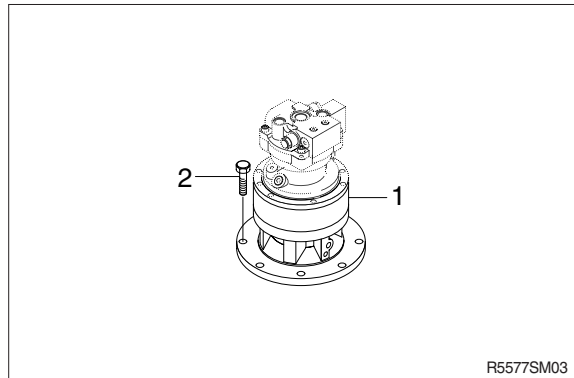

## 4. DISASSEMBLY AND ASSEMBLY OF REDUCTION GEAR

### 1) STRUCTURE

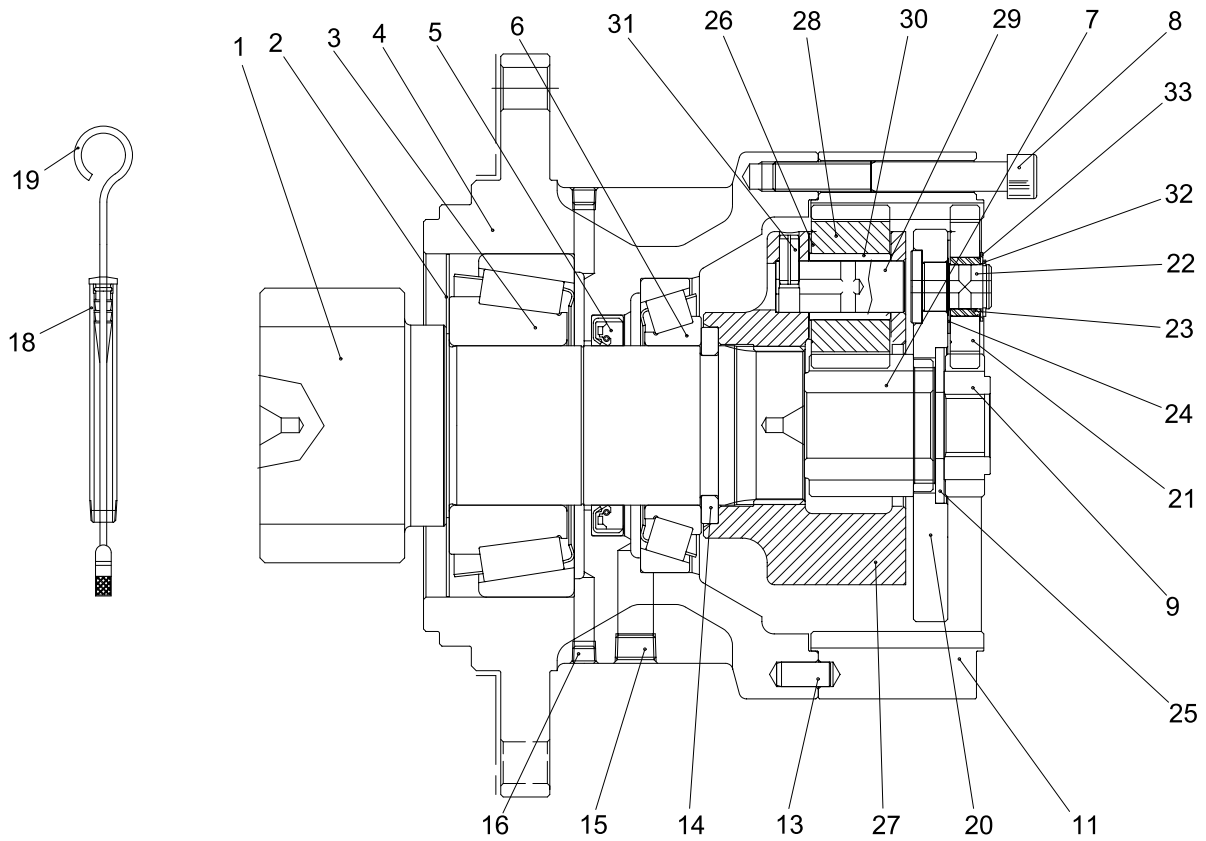

7072SM04

1	Shaft	12	Carrier assy 2	23	Bushing 1
2	Bearing cover	13	Dowel pin	24	Thrust washer 1
3	Taper roller bearing	14	Collar	25	Thrust washer 3
4	Case	15	Plug	26	Thrust washer 2
5	Oil seal	16	Plug	27	Carrier assy 2
6	Taper roller bearing	17	Cover	28	Planet gear 2
7	Sun gear 2	18	Pipe	29	Pin 2
8	Socket bolt	19	Level gauge	30	Bushing 2
9	Sun gear 1	20	Carrier assy 1	31	Spring pin
10	Carrier assy 1	21	Planet gear 1	32	Snap ring
11	Ring gear	22	Pin 1	33	Thrust washer 4

## 2) DISASSEMBLY

- (1) Remove the plug (15) and drain out gear oil.

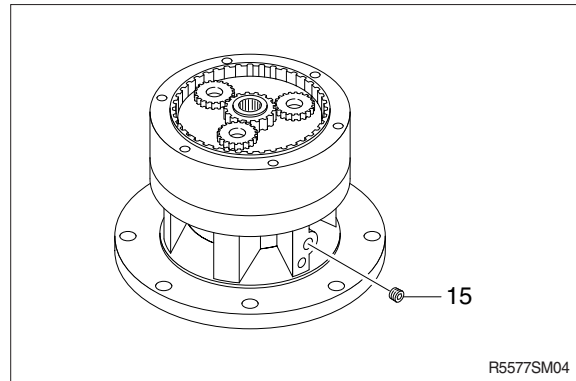

- (2) Remove the No.1 sun gear (9).

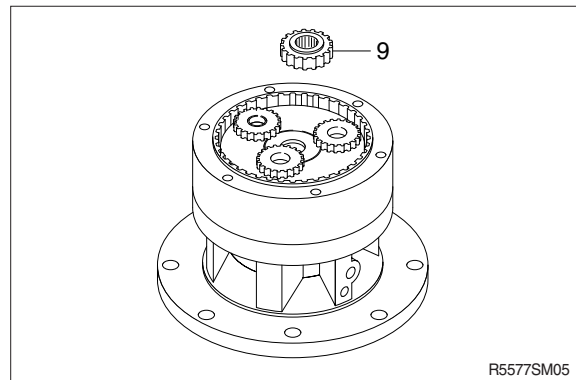

- (3) Remove the No.1 carrier sub-assembly (10) using the jig.

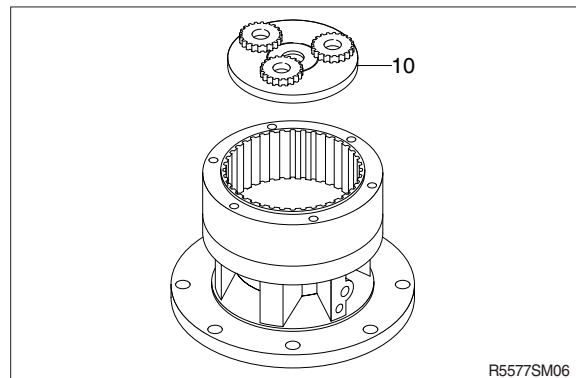

- (4) Remove the No.2 sun gear (7).

※ Pay attention to ensure the gear is not damaged during disassembling.

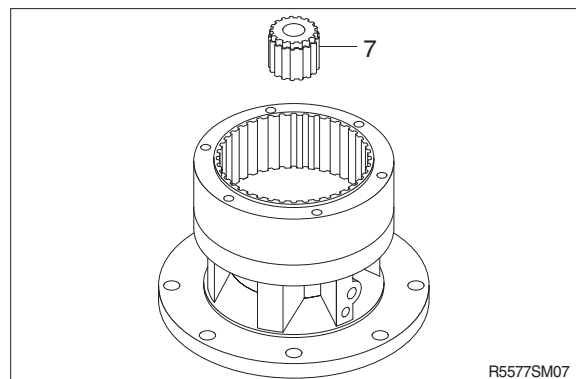

- (5) Remove the No.2 carrier sub assembly (12).

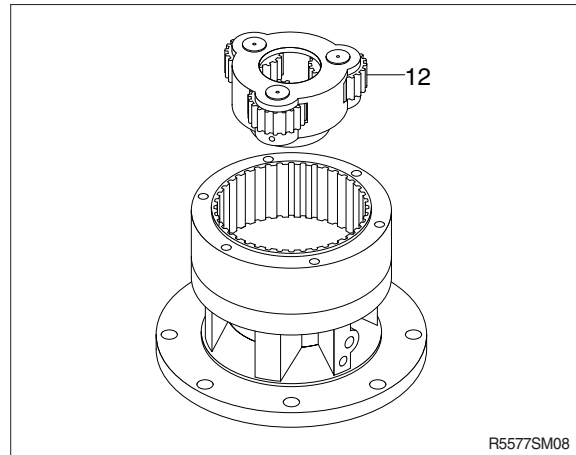

- (6) Remove the ring gear by the removal groove between the ring gear (11) and casing (4) by using jig.  
Full out the knock pin (13).  
Do not need to remove the knock pin (13) if it is not worn or damaged.

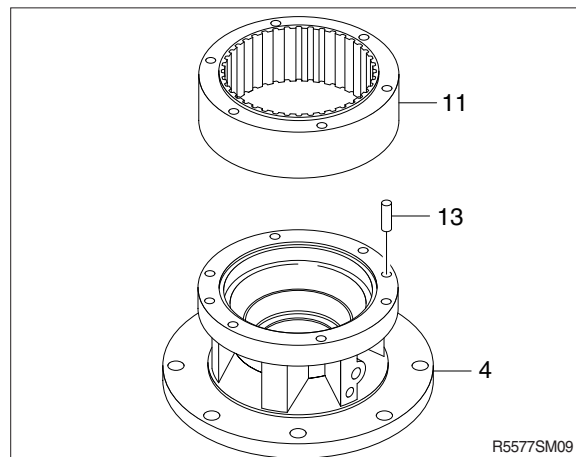

- (7) Put it on the working table with the drive shaft up.

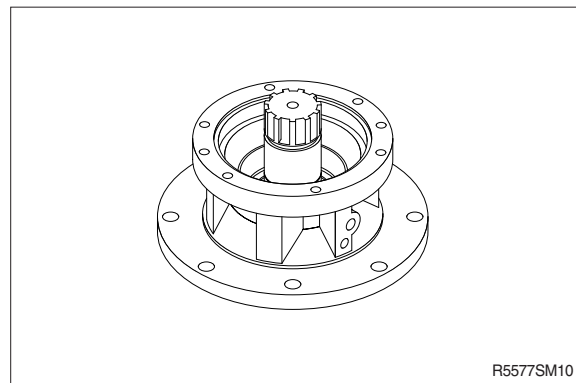

- (8) Disassemble the drive shaft (1) with bearing (3) by using jig.

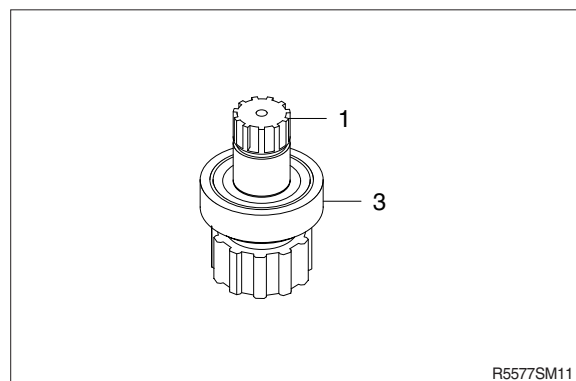



### 3) ASSEMBLING SWING REDUCTION GEAR

- (1) Place the case (4) on the reversing machine having the flange side of the case up.

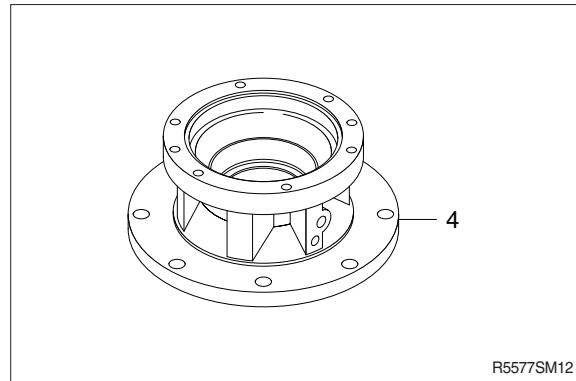

- (2) Install shaft assembly (1) into case (4).  
※ Be sure to clean the case before install, using washing machine with the temperature of 80°C  
※ Do not install shaft assembly by force.

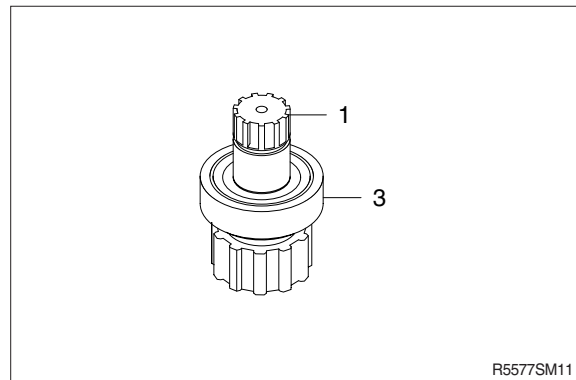

- (3) Reverse case and press to insert oil seal (5) by using pressing jig after spreading grease oil around the outside ring of the seal and bearing.  
Coat grease oil slightly on the lip surface to prevent any scratch when installing.  
※ Be sure to check by eye that the oil seal is seated completely after being installed.

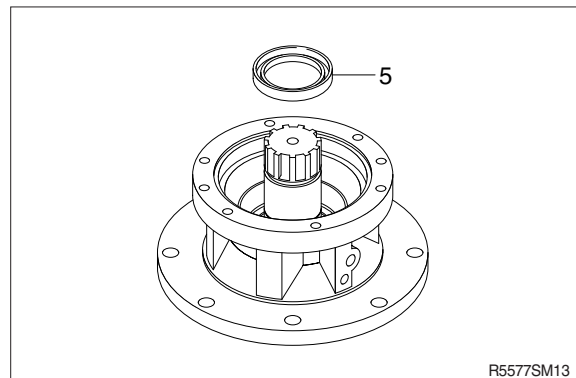

- (4) Clean the assembling surface of case and spread packing liquid (TH1105) as shown in figure.

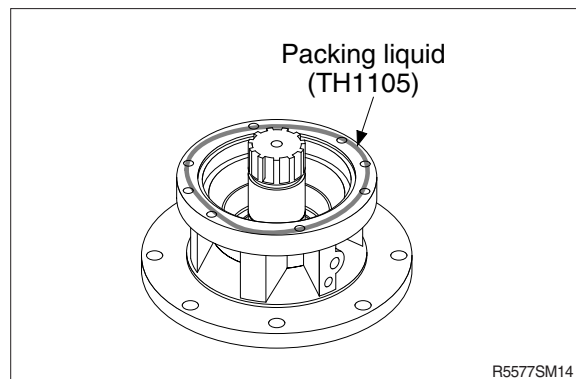

(5) Place ring gear (11) on the case by matching it with knock pin (13) hole.

(6) Insert 2 knock pins (13) by using jig.

※ Be sure to check the hole location of oil gage before inserting.

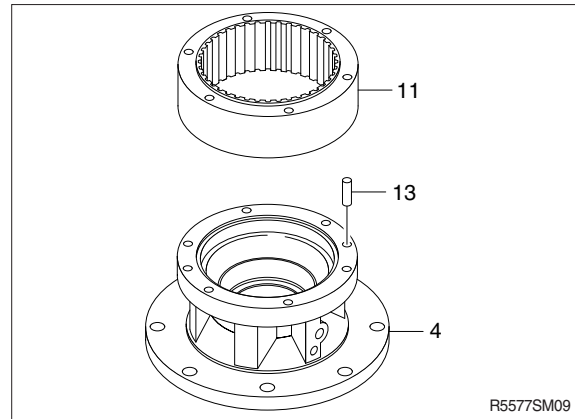

(7) Screw drain plug into drain plug (15) after winding sealing tape.

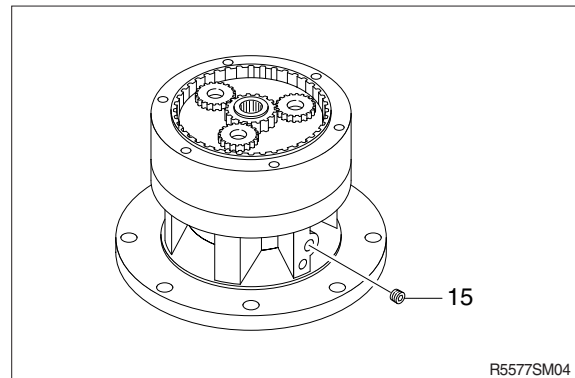

(8) Mount No.2 carrier assembly (12) in the case sub assembly and install bolts into 2 TAP holes (M6) as shown in figure.

※ Turn the carrier slowly by hand to adjust the matching holes when assembling.

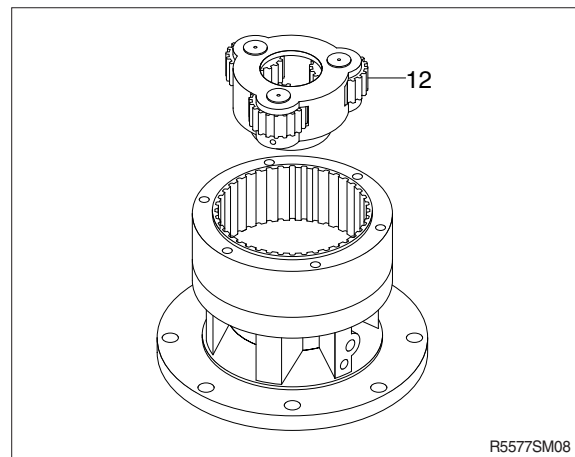

(9) Install No.2 sun gear (7).

※ Be sure to check the direction of sun gear (7) when assembling.

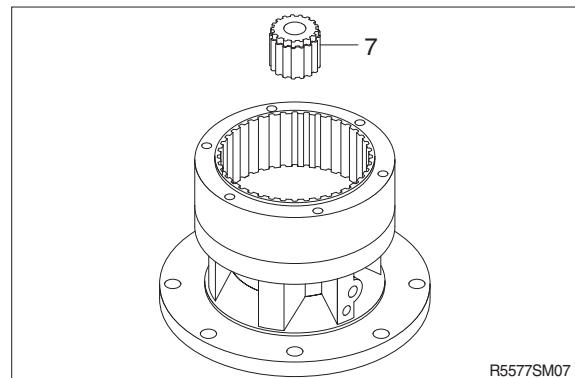



## ■ TYPE 2

### 1. REMOVAL AND INSTALL

#### 1) REMOVAL

- (1) Lower the work equipment to the ground and stop the engine.
- (2) Operate the control levers and pedals several times to release the remaining pressure in the hydraulic piping.
- (3) Loosen the breather slowly to release the pressure inside the hydraulic tank.

**▲ Escaping fluid under pressure can penetrate the skin causing serious injury.**

※ When pipes and hoses are disconnected, the oil inside the piping will flow out, so catch it in oil pan.

- (4) Disconnect hose assembly (12, 13).
- (5) Disconnect pilot line hoses (15, 29, 32, 33).
- (6) Sling the swing motor assembly (1) and remove the swing motor mounting bolts (21).

※ Motor device weight : 80 kg (176 lb)

- (7) Remove the swing motor assembly.  
※ When removing the swing motor assembly, check that all the piping have been disconnected.

#### 2) INSTALL

- (1) Carry out installation in the reverse order to removal.
- (2) Bleed the air from the swing motor.
  - ① Remove the air vent plug.
  - ② Pour in hydraulic oil until it overflows from the port.
  - ③ Tighten plug lightly.
  - ④ Start the engine, run at low idling and check oil come out from plug.
  - ⑤ Tighten plug fully.
- (3) Confirm the hydraulic oil level and check the hydraulic oil leak or not.

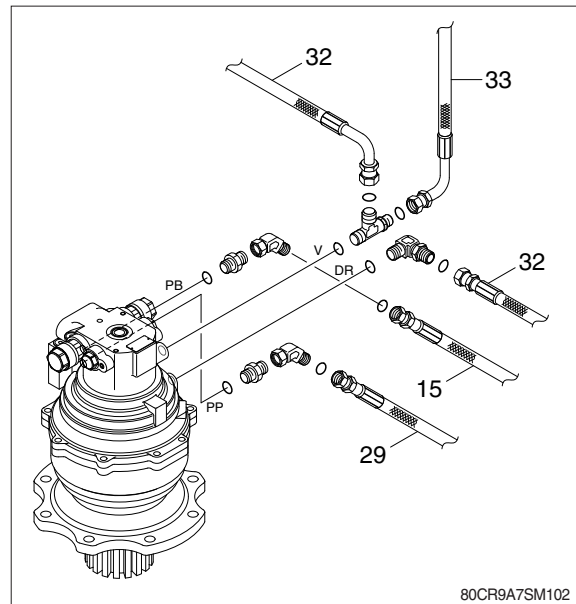
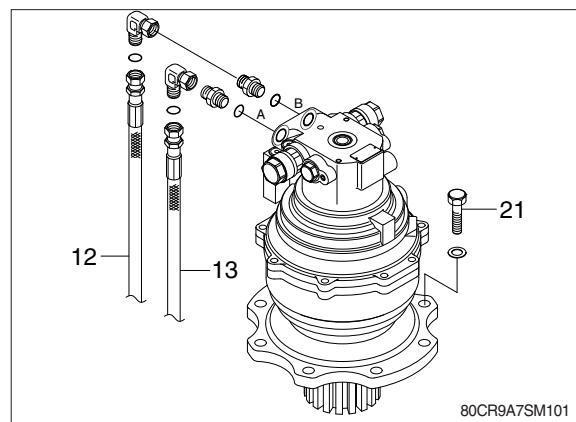

## 2) COMPONENTS (1/3)

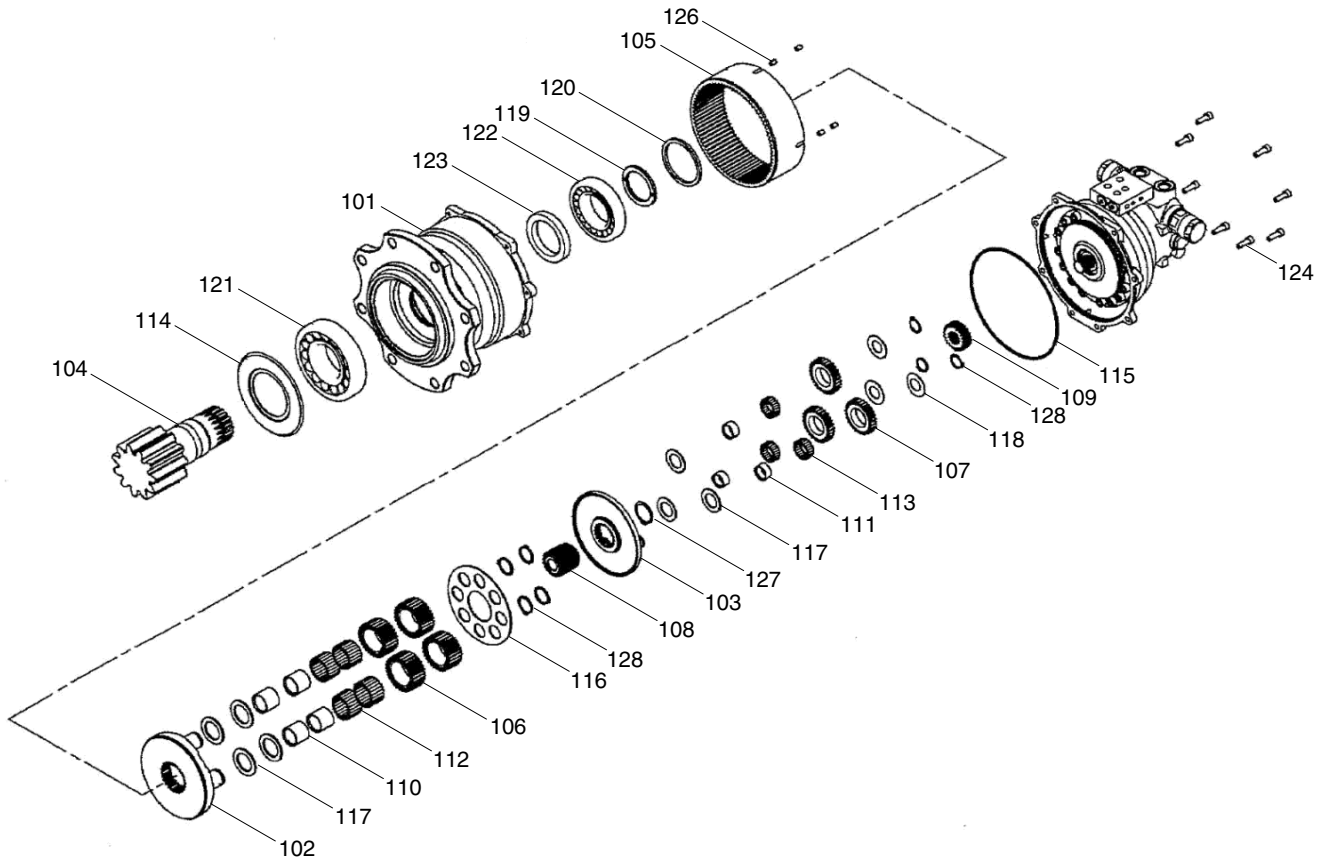

80CR9A2SM15

101	Body	110	Ring 1	119	Preload collar
102	Carrier 1	111	Ring 2	120	Ring
103	Carrier 2	112	Needle	121	Bearing
104	Pinion shaft	113	Needle	122	Bearing
105	Internal gear	114	Ring seal	123	Oil seal
106	Gear B1	115	O-ring	124	Screw
107	Gear B2	116	Thrust plate	126	Bushing pin
108	Gear S1	117	Thrust washer 1	127	Snap ring
109	Gear S2	118	Thrust washer 2	128	Snap ring

## COMPONENTS (2/3)

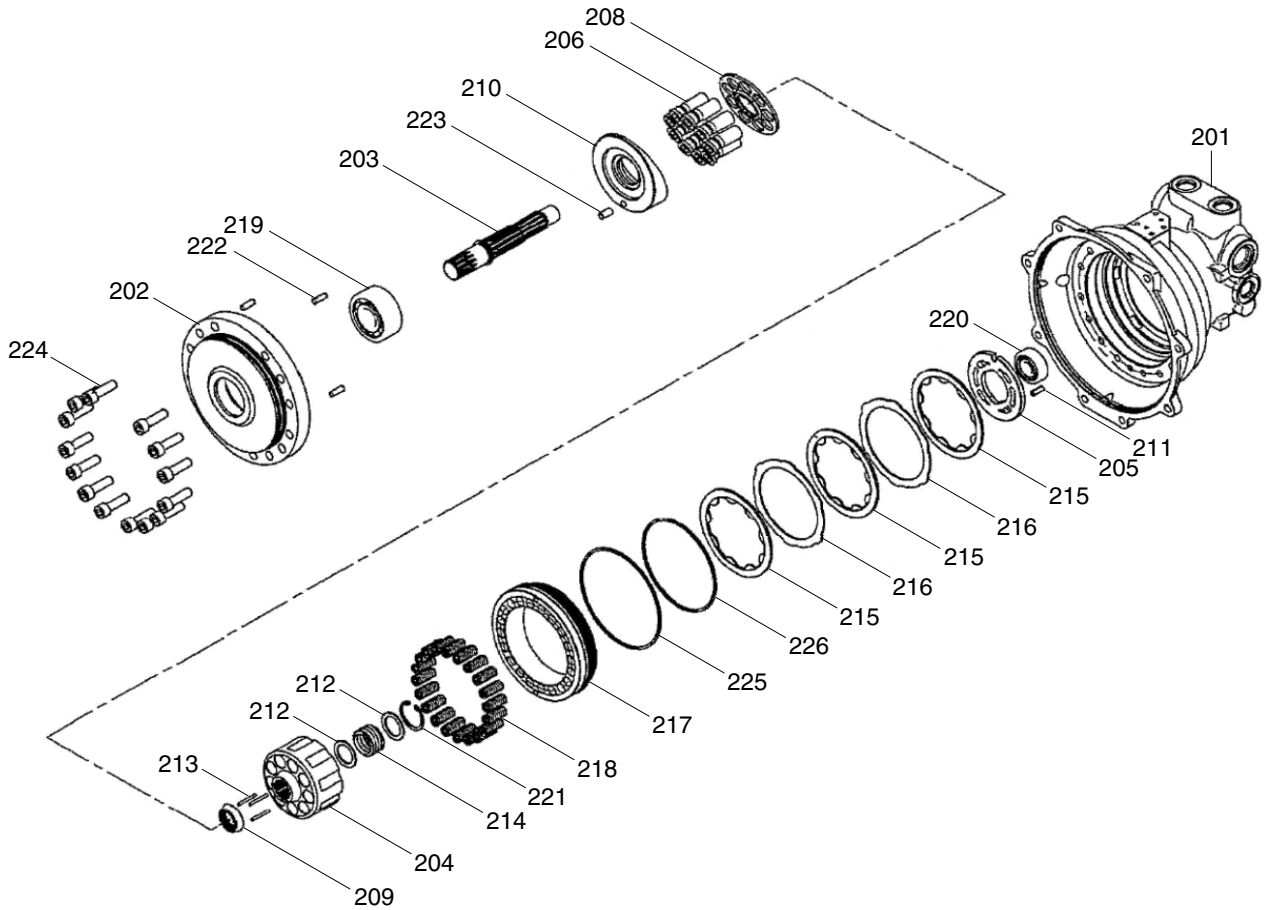

80CR9A2SM16

201	Body H	211	Spring pin	220	Bearing
202	Plate S	212	Retainer	221	Snap ring
203	Shaft	213	Pin	222	Pin
204	Cylinder barrel	214	Spring C	223	Pin
205	Valve plate	215	Disk plate	224	Screw
206	Piston assy	216	Steel plate	225	O-ring
208	Shoe holder	217	Brake piston	226	O-ring
209	Barrel holder	218	Spring B		
210	Swash plate	219	Bearing		

## COMPONENTS (3/3)

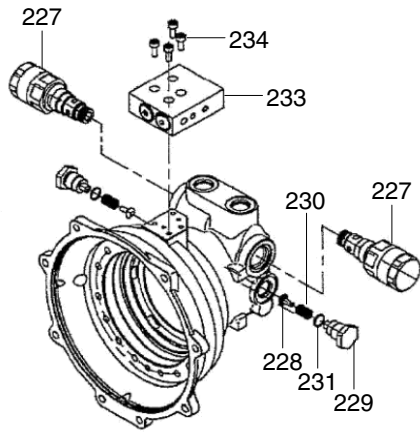

DETAIL ITEM 233

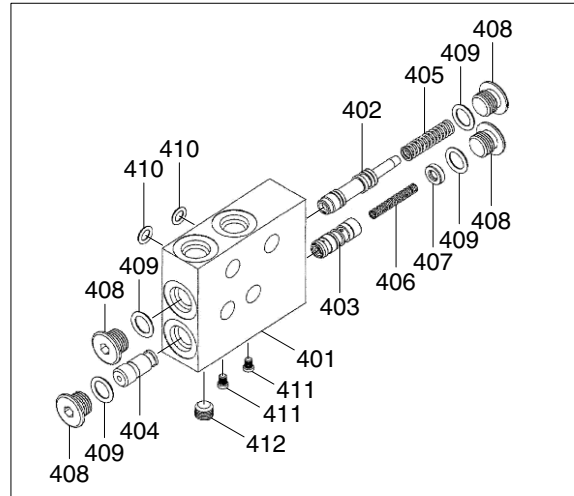

DETAIL ITEM 227

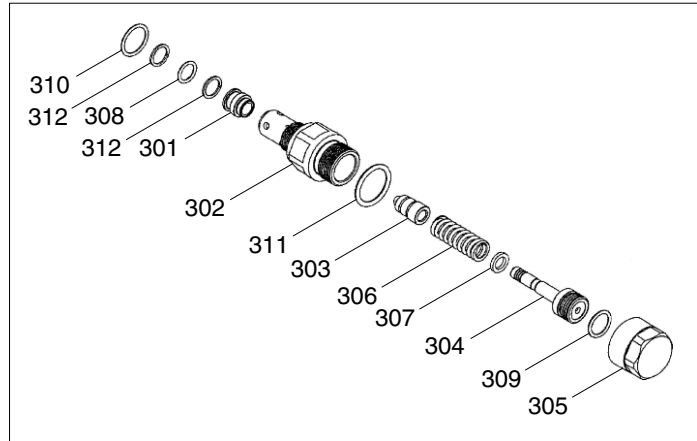

80CR9A2SM16-1

227	Relief valve	305	Cap	404	Stopper
228	Check valve	306	Spring	405	Spring
229	Plug	307	Spacer	406	Spring
230	Spring	308	O-ring	407	Spring holder
231	O-ring	309	O-ring	408	Plug
233	P/brake timer valve	310	O-ring	409	O-ring
234	Screw	311	O-ring	410	O-ring
301	Seat	312	Back-up ring	411	Metal plug
302	Retainer	401	Body	412	Plug
303	Poppet	402	Spool		
304	Piston	403	Piston		



## 2) GENERAL ATTENTION

Please pay attention following points.

- (1) Working should be done at the clean place and pay attention not to attach dust, paint cake and water. And prepare the clean box to put into the disassembled parts.
- (2) Before disassembling, clean up the dust which is attached to the outside of the swing motor and take out paint which is attached to the binding parts by the wire brush.
- (3) To make the original position when assembling, make a marking before disassembling.
- (4) Give special care to protect parts from damage.
- (5) Wash parts with washing oil sufficiently.
- (6) Check parts whether there is friction loss or seize and take out burr with sand paper.
- (7) Change the seals and snap rings to new ones.

## 3) DISASSEMBLY AND ASSEMBLY PROCEDURE

As the swing motor composes 2 blocks (hydraulic motor and reduction gear), explain each block disassembly and assembly procedure.

And please refer to the page 7-67~69.

## 4) TOOLS FOR DISASSEMBLY AND ASSEMBLY

No.	Tool	
1	Preset type hand torque wrench	45 N (JIS B4650)
2		90 N (JIS B4650)
3	Hexagon bar bit for above wrench	Two-plane width 5
4		Two-plane width 6
5		Two-plane width 8
6	Single purpose type hand torque	T = $12 \pm 0.6$ kgf · m (86.8 ± 4.4 lbf · ft) Two-plane 27 T = $22.5 \pm 2.5$ kgf · m (163 ± 18.1 lbf · ft) Two-plane 41
7	Hexagon bar wrench	Two-plane width 5
8		Two-plane width 6
9		Two-plane width 8
10	Spanner	Two-plane width 27 Two-plane width 41
11	Minus driver	Width 6~10
12	Snap ring pliers	∅ 35 for hole
13		∅ 30 for shaft
14		∅ 48 for shaft
15	Hammer	-
16	Plastic hammer	-
17	Other	Grease
18		(oil designated hydraulic oil)
19		Wire brush
20		Sand paper
21		Anti-loose adhesive (three bond #1305)

### 3. DISASSEMBLY

#### 1) HYDRAULIC MOTOR

(1) Loose the hexagon socket head cap bolts (124), and take out the hydraulic motor assembly from the reduction gear body.

- Tools required :  
Hexagon bar wrench : 6 mm

※ When taking out the hydraulic motor assembly from the reduction gear body, the drain port should be open.  
When it is difficult to take out, insert the minus driver into the binding face to the body. If a part of the binding the surface becomes convex by the driver, take out the burr completely.



(2) Loose the hexagon socket head cap bolts (234), and take out the timer valve (233) from the hydraulic motor assembly.

- Tools required :  
Hexagon bar wrench : 5 mm

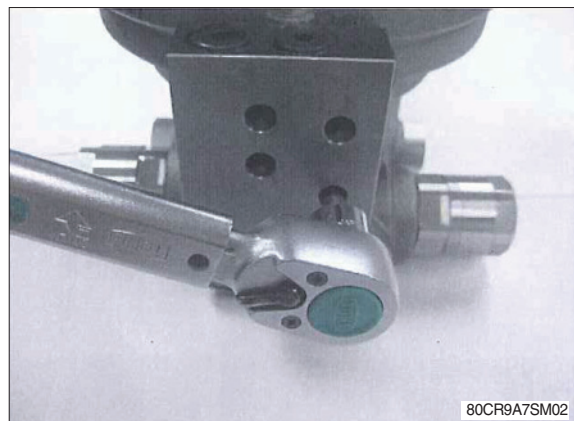

(3) Take out the relief valve assembly (227).

- Tools required :  
Spanner : 41 mm

※ Do not disassemble the relief valve assembly, unless it is necessary.

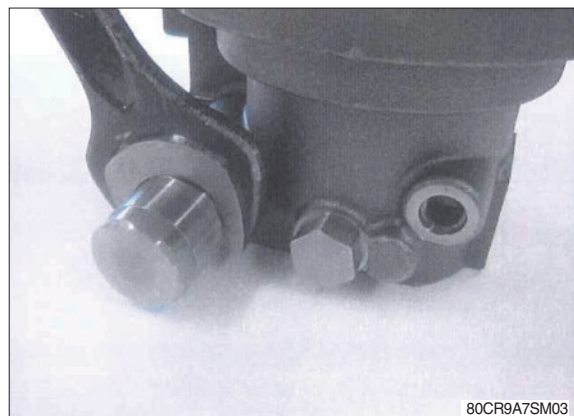

(4) Loose the hexagon socket head cap bolts (224), and take out it.

- Tools required :  
Hexagon bar wrench : 8 mm

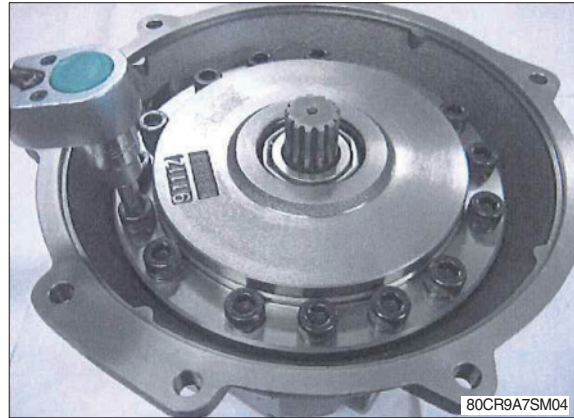

(5) Take out the plate S (202).

- ※ Pay attention not to drop off swash plate (210).

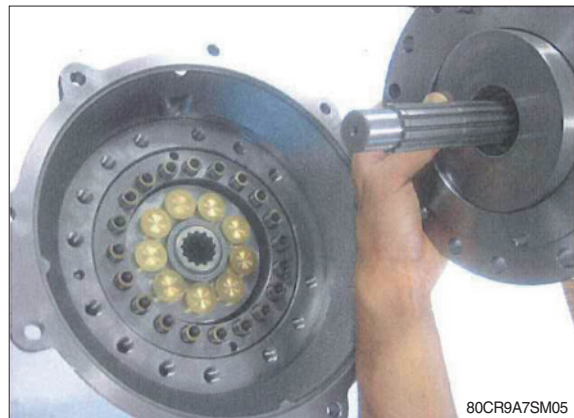

(6) Take out the swash plate (210) and the shaft kit from the plate S (202).

- ※ When it is difficult to take out the shaft, hit the opposite side slightly by the plastic hammer.

As the bearing (216) is pressed into the shaft, do not disassemble unless it is necessary to change the bearing.

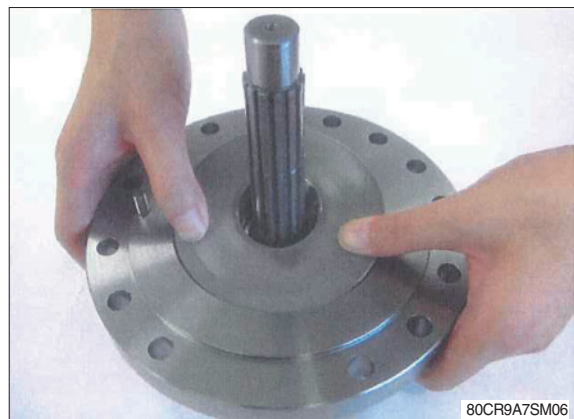

(7) Take out the spring B (218) from the brake piston (217).

- Spring B (218) : 20 pcs



(8) Take out the parallel pin (222) from the plate S (202).

- Parallel pin (222) : 3 pcs

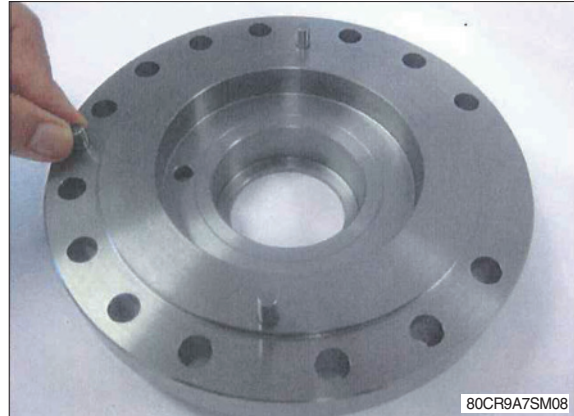

80CR9A7SM08

(9) Take out the cylinder barrel kit.

※ Pay attention not to lose parts, which are scattered easily.

There is a possibility to stay valve plate (205) on bottom face of cylinder barrel. Pay attention not to drop off it.



80CR9A7SM09

(10) Take out the piston assemblies (206), the shoe (208), the barrel holder (209) and the pin (213).

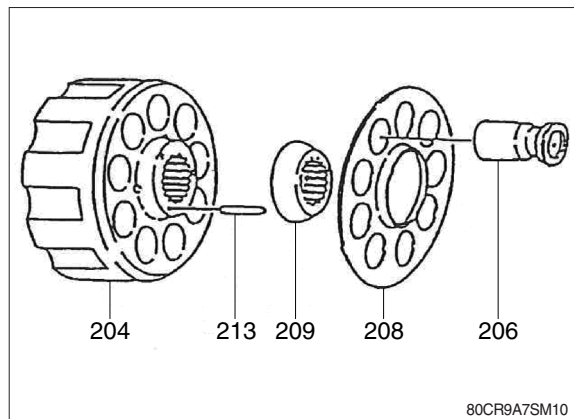

80CR9A7SM10

(11) Take out the snap ring (221), the retainer (212) and the spring C (214).

- Tools required :  
Snap ring plier :  $\varnothing 35$  for hole

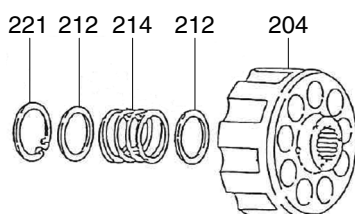

80CR9A7SM11-1

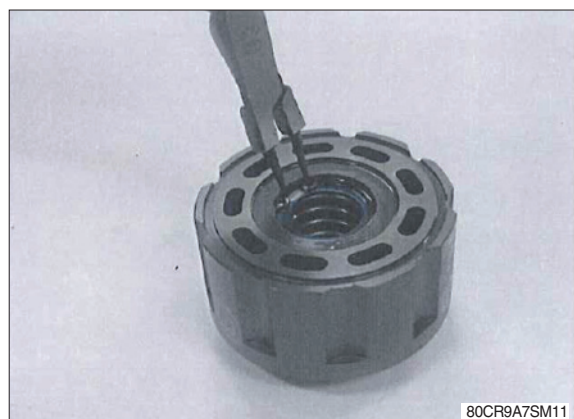

80CR9A7SM11



(12) Take out the brake piston (217) and the O-ring (225, 226) from body H (201).

- ※ Blow in air from PP port little by little to remove brake piston.  
Pay attention not to come off it suddenly.

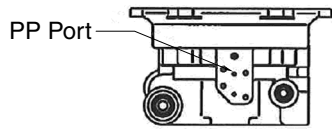

80CR9A7SM12-1



80CR9A7SM12

(13) Take out the disk plate (215), and the steel plate (216).

- Disk plate (215) : 3 pcs
- Steel plate (216) : 2 pcs

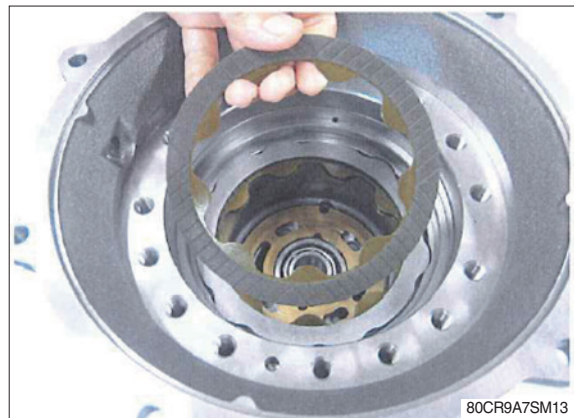

80CR9A7SM13



80CR9A7SM14

(14) Take out the valve plate (205).



80CR9A7SM15

(15) Loose the plug (229), and take out the check valve (228) and the spring (230).  
(2 locations)

- Tools required :  
Spanner : 27 mm



## 2) REDUCTION GEAR

(1) Take out the O-ring (115).

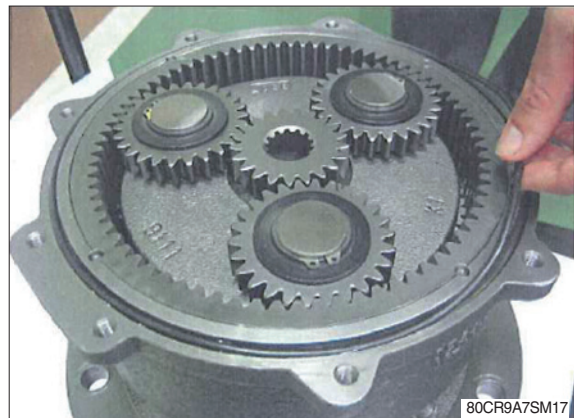

(2) Take out the S2 gear (109).

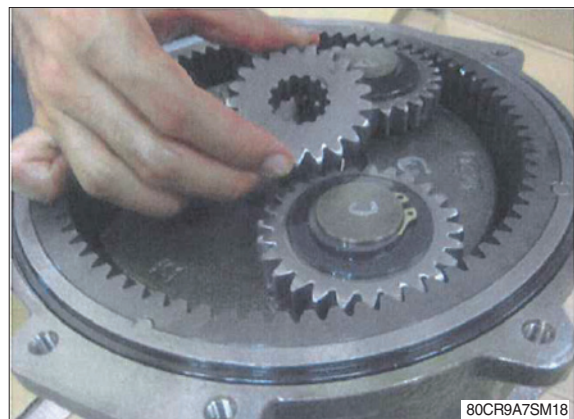

(3) Take out the carrier 2 kit.



(4) Take out the carrier 1 kit.

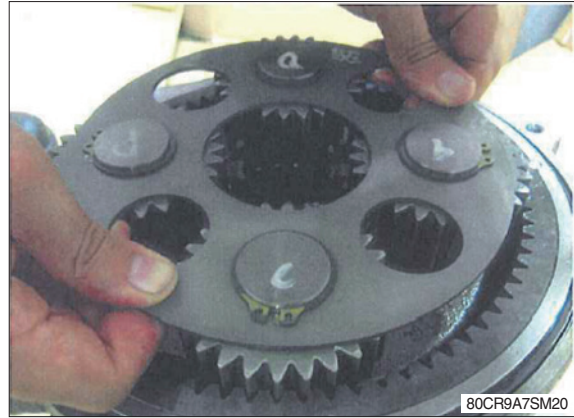

(5) Take out the snap ring (128), the thrust washer (118), the b2 gears (107) and the needles 2 (113) from the carrier 2 kit.

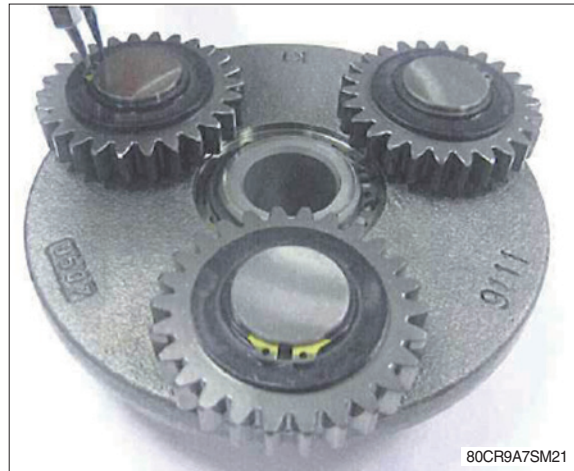

(6) Take out the snap ring (128), and the S1 gear (108) from the carrier 2 kit.





- (7) Take out the ring 2 (111) and thrust washers (117) from the carrier 2 kit.

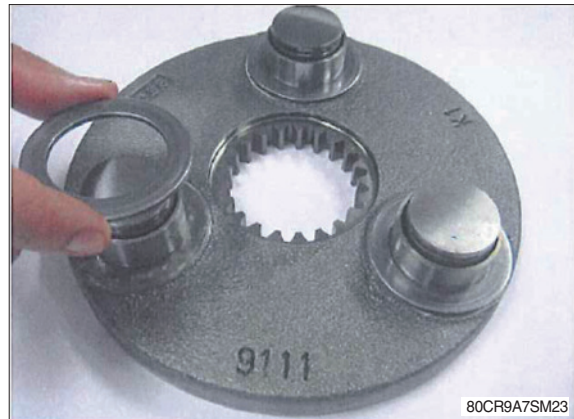

- (8) Take out the snap ring (128) and the thrust plate 1 (116) from the carrier 1 kit.



- (9) Take out the b1 gears (106) and needles (112) from the carrier 1 kit.



- (10) Take out the rings 1 (110) and the thrust washers (117) from the carrier 1 kit.



## 4. ASSEMBLY

### 1) HYDRAULIC MOTOR SECTION

- (1) Press-fit the bearing (220) and spring pin (211) into the body H (201).



- (2) Insert the 2 check valves (228) (1 pc/side), springs (230) (1pc/side) and plug (229) (1pc/side) with O-ring (231) in that order into the body H (201). (2 locations)

- Tools required :  
Spanner : 27 mm  
Torque wrench

- ※ Apply grease slightly to the O-ring and assemble to pay attention not biting the seals.

- Plug tightening torque :  
 $12 \pm 0.6 \text{ kgf} \cdot \text{m}$  ( $86.8 \pm 4.34 \text{ lbf} \cdot \text{ft}$ )

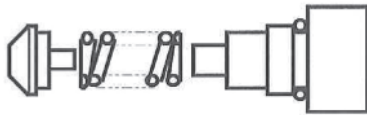
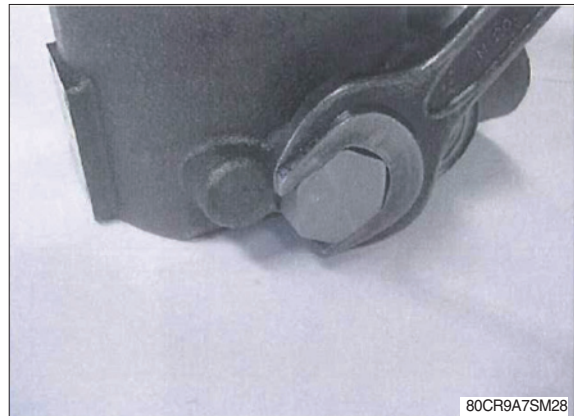

80CR9A7SM28-1

- (3) Place the valve plate (205) onto the body H (201).

- ※ The steel face of the valve plate should be downside and assemble.

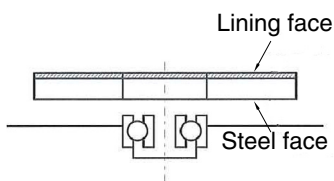

80CR9A7SM29-1



(4) Assemble the disk plate (215) and steel plate (216).

- ※ Number of parts count on installing
  - Disc plate : three
  - Steel plate : two
- ※ Please assemble exact number of parts and exact order. (refer the below drawing)
- ※ Please install disc plate ditch with accuracy in order to install cylinder barrel assy into it on (9), see the page 7-81.

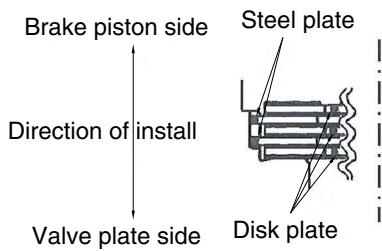
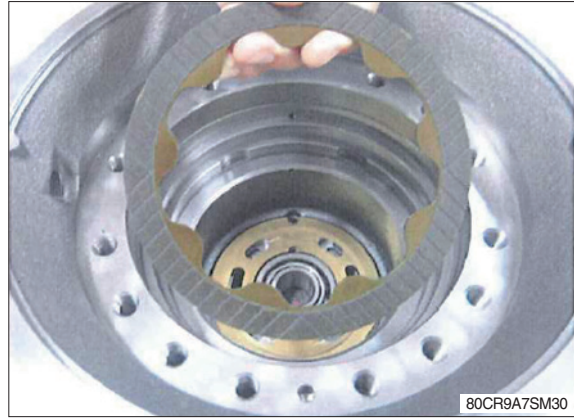

80CR9A7SM31-1



(5) Make the brake piston assembly which placed O-rings (225, 226) on brake piston (217), and place it onto the body H (201).

Place the brake piston assembly onto plate S placed 3 pins, then place it onto the body H as matched pin hole position. After that, press-fit it by tightening hexagon bolts little by little.

Check no pushed out, scratches and dust on O-ring at this time.

To preven the brake piston assembly falling off, apply grease on plate S.

Take out the plate S after placed brake piston assembly.

- ※ Pay attention to jam seal parts, install them applying grease on O-rings.

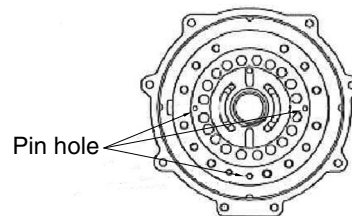

80CR9A7SM32-1



(6) Place the retainer (212), spring C (214) and retainer (212) in that order into the cylinder barrel (204), and then secure them with the snap ring (221).

· Tools required :

Snap ring plier :  $\varnothing 28$  for hole

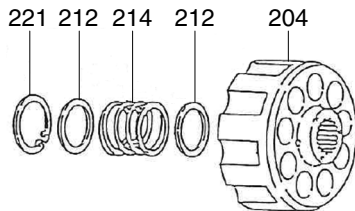

80CR9A7SM11-1

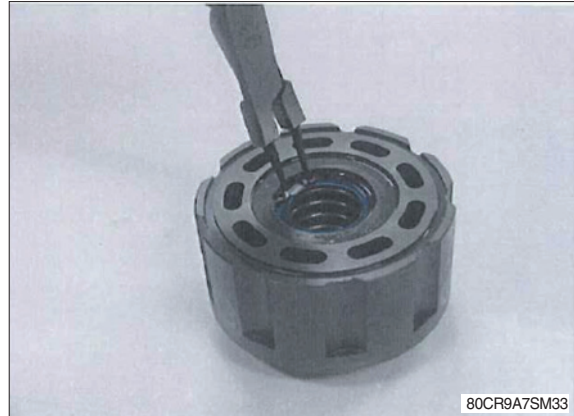

80CR9A7SM33

(7) Make the shoe holder assembly which has the 9 piston assemblies (206) placed on the shoe holder (208).



80CR9A7SM34

(8) Place the 3 pins (213), barrel holder (209) and the shoe holder assembly onto the cylinder barrel (204) to make up a cylinder barrel assembly.

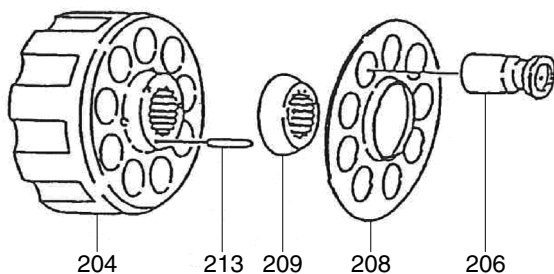

80CR9A7SM10



80CR9A7SM35

(9) Insert cylinder barrel assembly along ditch of disk plate into body H (201).



(10) Place the parallel pins (222) into the plate S (202).

· Parallel pin (222) : 3 pcs

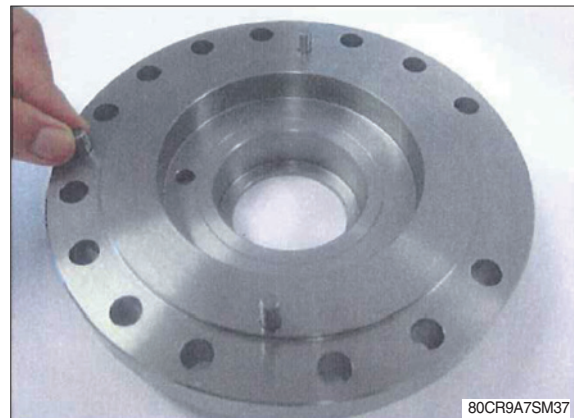

(11) Insert the spring B (218) into the brake piston (217).

· Spring B (218) : 20 pcs



(12) Press-fit bearing (219) with shaft (203).



(13) Place the shaft kit and the swash plate (210) into the plate S (202).

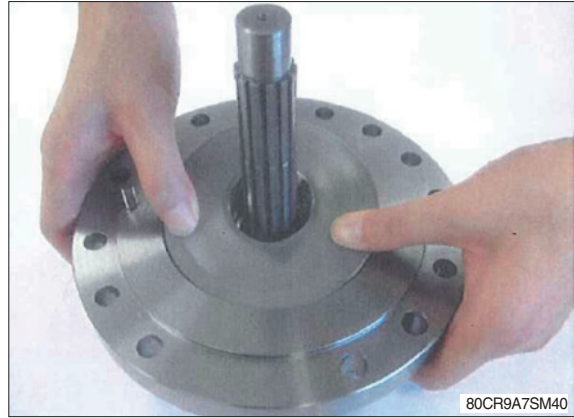

(14) Join the body H (201) and the plate S (202).

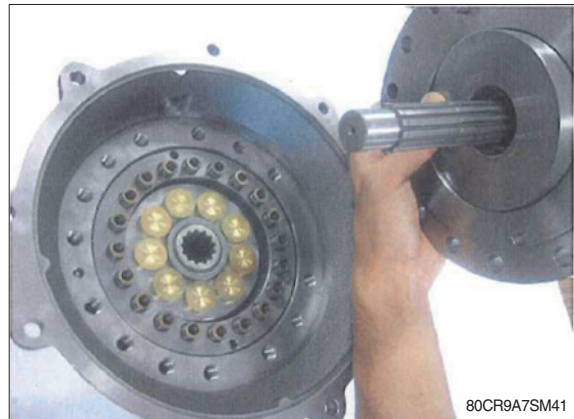

(15) Bolt the plate S (202) together with the 14 hexagon socket head cap bolts (224).

- Tools required :  
Hexagon bar wrench : 8 mm  
Torque wrench
- Bolt tightening torque :  
 $6 \pm 0.3 \text{ kgf} \cdot \text{m}$  ( $43.4 \pm 2.17 \text{ lbf} \cdot \text{ft}$ )



(16) Screw up the relief valve assembly.  
(both side)

- Tools required :  
Spanner : 41 mm  
Torque wrench
- Plug tightening torque :  
 $22.5 \pm 2.5 \text{ kgf} \cdot \text{m}$  ( $163 \pm 18.1 \text{ lbf} \cdot \text{ft}$ )

※ Once the relief valve is disassembled, replace the O-ring and the back up ring in the below, and screw the cap with the following torque.

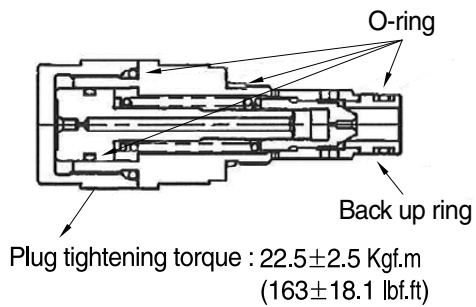

80CR9A7SM43-1



(17) Screw up the timer valve.

- Tools required :  
Hexagon bar wrench : 5 mm  
Torque wrench
- Plug tightening torque :  
 $1.2 \pm 0.1 \text{ kgf} \cdot \text{m}$  ( $8.7 \pm 0.72 \text{ lbf} \cdot \text{ft}$ )

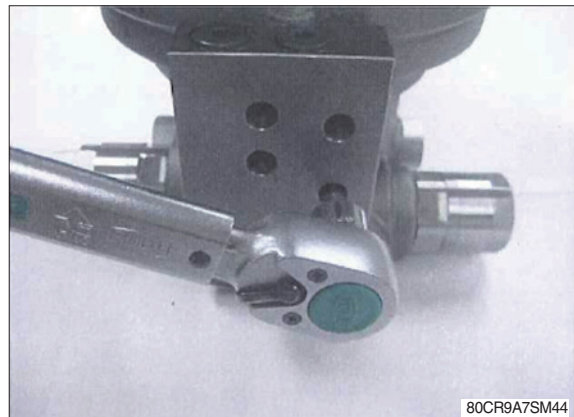



## 2) REDUCTION GEAR SECTION

- (1) Place the ring (110) (1 pc/pin) and the thrust washer (117) (1 pc/pin) in that order onto the pins of the carrier 1 (102). (4 locations)



- (2) Place the b1 gear (106) (1 pc/pin) and the 92 needles 1 (112) (24 pcs/pin) in that order onto the 4 pins of the carrier 1 (102). (4 locations)



- (3) Place the thrust plate (116) and the 4 snap rings (128) (1 pc/pin) to make up a carrier 1 kit.

- Tools required :  
Snap ring plier :  $\varnothing$  30 for shaft

- ※ Pay attention to the direction of the snap ring. The edge side should be uppermost. Pay attention not to open the snap ring too much. The snap ring which was opened too much should lose tension and be replaced.



- (4) Place the thrust washer (117) (1 pc/pin) and the ring 2 (111) (1 pc/pin) in that order onto the pin of the carrier 2 (103). (3 locations)



- (5) Place the S1 gear (108) onto the carrier 2 (103) to make up a carrier 2 kit.

· Tools required :

Snap ring plier :  $\varnothing$  48 for shaft

- ※ Pay attention to the direction of the snap ring. The edge side should be uppermost. Pay attention not to open the snap ring too much. The snap ring which was opened too much should lose tension and be replaced.



- (6) Place the b2 gears (107) (1 pc/pin), the 72 needle (113) (24 pcs/pin), and the snap ring (128) in that order onto the pin of the carrier 2 (103). (3 locations)

· Tools required :

Snap ring plier :  $\varnothing$  30 for shaft

- ※ Pay attention to the direction of the snap ring. The edge side should be uppermost. Pay attention not to open the snap ring too much. The snap ring which was opened too much should lose tension and be replaced.

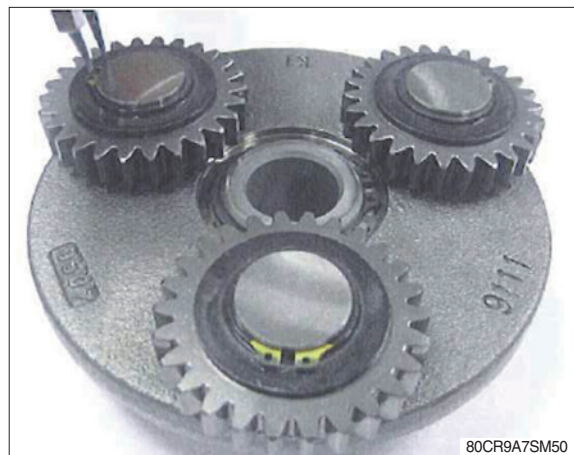

- (7) Place the carrier 1 assembly into the body (101) align spline of carrier to the pinion shaft (104).

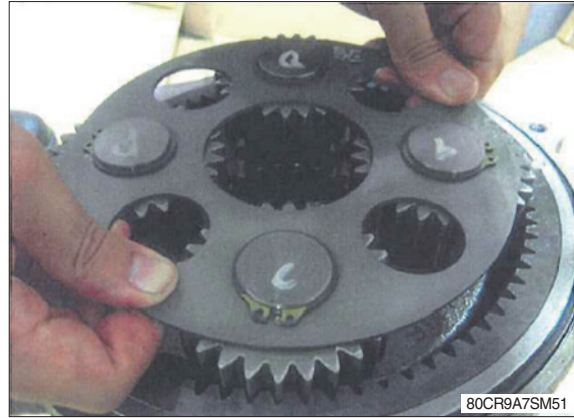

- (8) Place the carrier 2 assembly into the body (101) align spline of S1 gear (108) to the b1 gear (106).

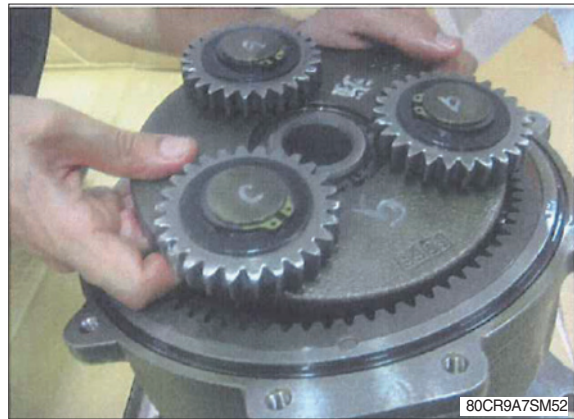

- (9) Place the S2 gear (109) into the carrier 2 assembly.

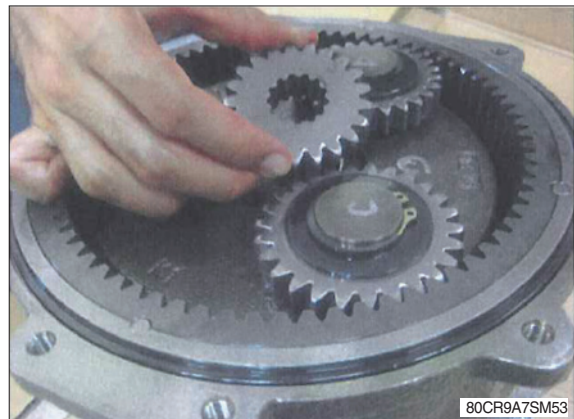

- (10) Place the O-ring (115) onto the body (101).





(11) Fill body (101) with hydraulic oil.

- ※ Oil : ISO VG 46 or equivalent  
Oil amount : 2 to 3 mm below top of the B2 gear.  
Wipe oil off flange surface if it is spilled.

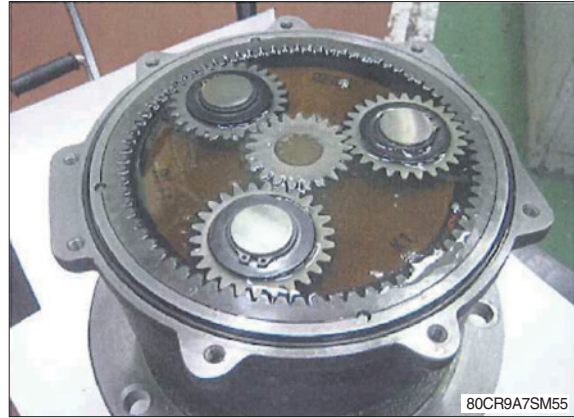

(12) Join the hydraulic motor and the body, and then bolt them together with the hexagon socket head cap bolts (124).

- Tools required :  
Hexagon bar wrench : 6 mm  
Torque wrench
- ※ Align the shaft of the motor to the S2 gear.  
Apply anti-loose adhesive to the screws.
- Plug tightening torque :  
 $3 \pm 0.3 \text{ kgf} \cdot \text{m}$  ( $21.7 \pm 2.17 \text{ lbf} \cdot \text{ft}$ )



## GROUP 6 TRAVEL DEVICE

### 1. REMOVAL AND INSTALL

#### 1) REMOVAL

- (1) Swing the work equipment 90° and lower it completely to the ground.
- (2) Operate the control levers and pedals several times to release the remaining pressure in the hydraulic piping.
- (3) Loosen the breather slowly to release the pressure inside the hydraulic tank.

**▲ Escaping fluid under pressure can penetrate the skin causing serious injury.**

※ **When pipes and hoses are disconnected, the oil inside the piping will flow out, so catch it in oil pan.**

- (4) Remove the track shoe assembly.  
For details, see removal of track shoe assembly.
- (5) Remove the cover.
- (6) Remove the hose.  
※ **Fit blind plugs to the disconnected hoses.**
- (7) Remove the bolts and the sprocket.
- (8) Sling travel device assembly(1).
- (9) Remove the mounting bolts(2), then remove the travel device assembly.  
· Weight : 85 kg (190 lb)

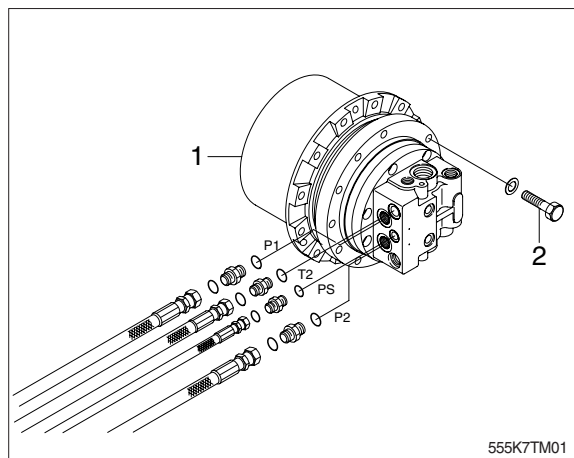

#### 2) INSTALL

- (1) Carry out installation in the reverse order to removal.
- (2) Bleed the air from the travel motor.
  - ① Remove the air vent plug.
  - ② Pour in hydraulic oil until it overflows from the port.
  - ③ Tighten plug lightly.
  - ④ Start the engine, run at low idling, and check oil come out from plug.
  - ⑤ Tighten plug fully.
- (3) Confirm the hydraulic oil level and check the hydraulic oil leak or not.

## 2) STRUCTURE

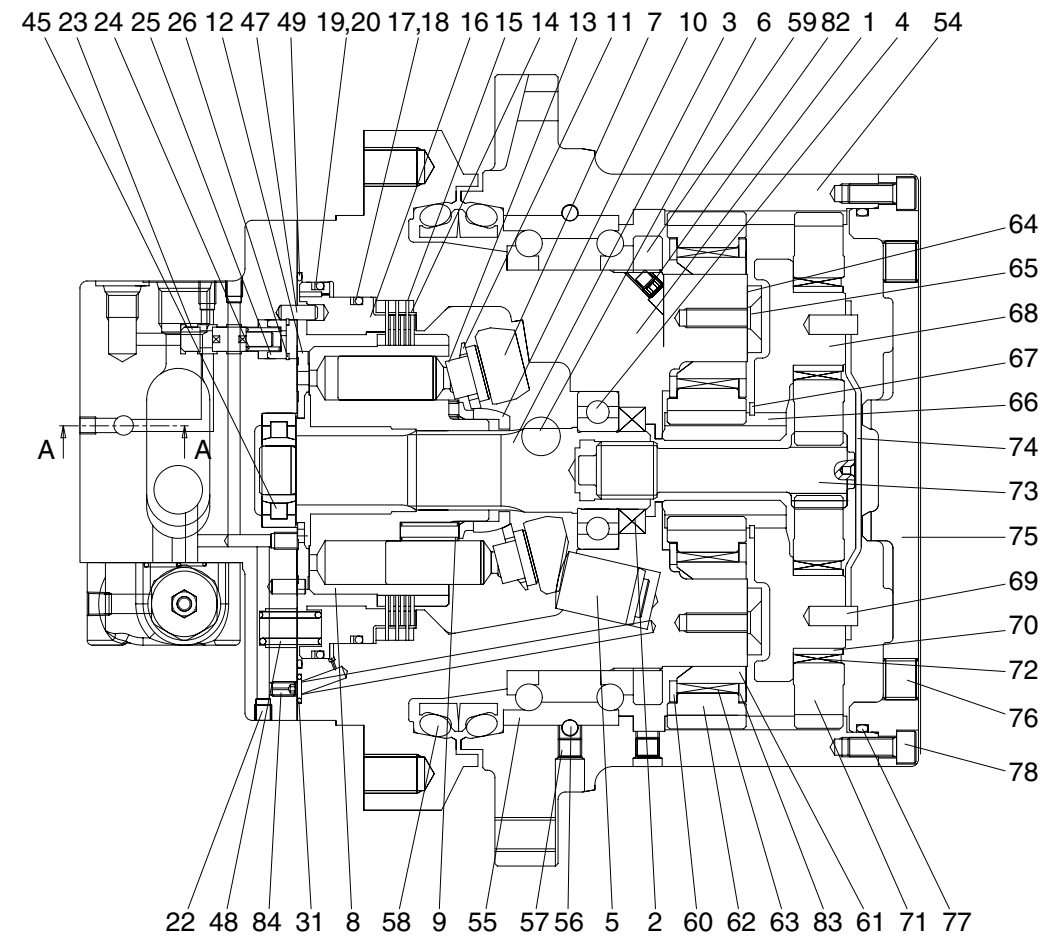
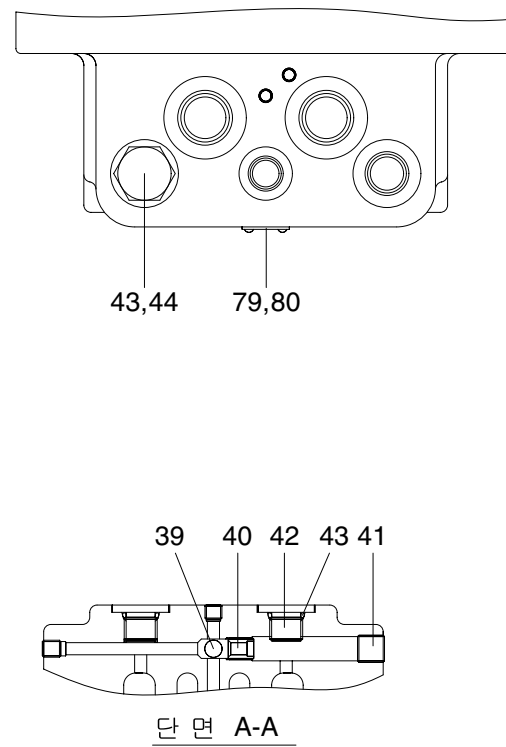
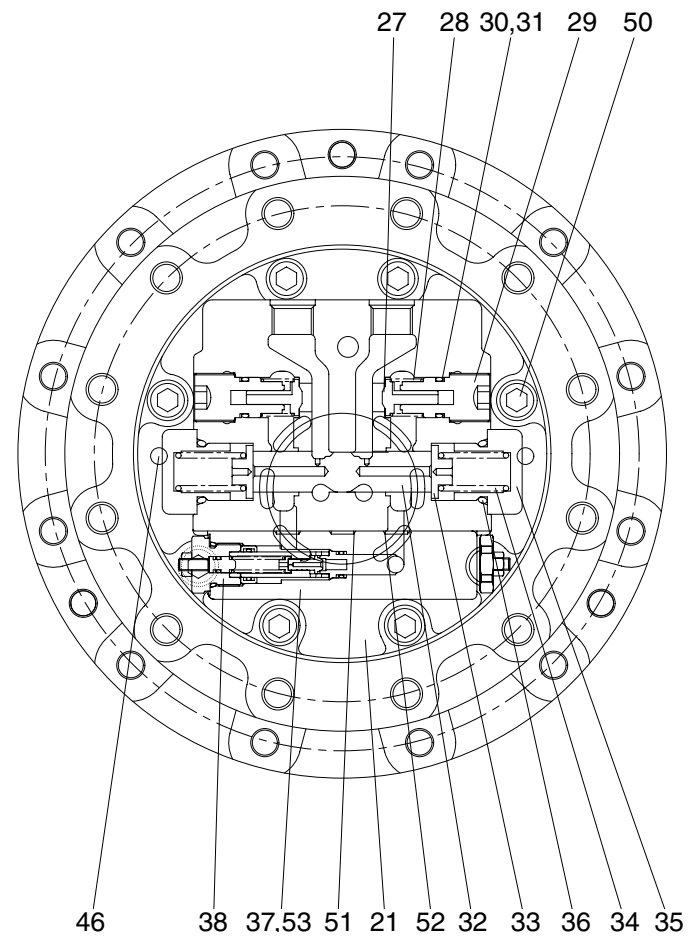

1 Shaft casing	15 Parking plate
2 Oil seal	16 Parking piston
3 Shaft	17 O-ring
4 Bearing	18 Back up ring
5 Swash piston	19 O-ring
6 Swash steel ball	20 Back up ring
7 Swash plate	21 Rear cover
8 Cylinder block	22 Plug
9 Spring	23 Spool
10 Ball guide	24 Spring
11 Set plate	25 Stopper
12 Valve plate	26 Snap ring
13 Piston	27 Check
14 Friction plate	28 Spring

29 Plug
30 O-ring
31 Back up ring
32 Main spool
33 Spring seat
34 Spring
35 Plug
36 O-ring
37 Relief valve assy
38 Relief valve assy
39 Steel ball
40 Check seat
41 Plug
42 Plug

43 O-ring
44 Plug
45 Ball bearing
46 Parallel pin
47 Parallel pin
48 Spring
50 Wrench bolt
51 O-ring
52 O-ring
53 Wrench bolt
54 Ring gear
55 Angular bearing
56 Steel ball
57 Plug

58 Floating seal
59 Nut
60 Washer
61 Collar
62 Planetary gear
63 Needle bearing
64 Plate
65 Bolt
66 Sun gear
67 Snap ring
68 Carrier
69 Spring pin
70 Collar
71 Planetary gear

72 Needle bearing
73 Drive gear
74 Thrust plate
75 Ring gear cover
76 Plug
77 O-ring
78 Wrench bolt
79 Name plate
80 Rivet
82 Set screw
83 Washer
84 Plug

80CR92TM03

### 3) TOOLS AND TIGHTENING TORQUE

#### (1) Tools

Name of tools	Size	Name of applied parts
Hexagonal L-wrench	2.5	Orifice (84)
	4	Plug (22)
	6	Plug (41), wrench bolt (65, 78)
	8	Plug (76)
	-	Plug (29, 42, 44)
Socket wrench / spanner	27	Plug (35), Relief valve assembly (38)
Snap-ring plier (for holes, axis)		Snap ring (26, 67)
Solder hammer		Bearing (4), Pin (46, 47), Oil seal (2)
Torque wrench		Size : 500, 3000
Jig for assembling oil seal		Oil seal (2)
Induction heating apparatus for bearing		Bearing (4)

#### (2) Tightening torque

No.	Name	Size	Torque
			kgf · m
22	Plug	NPT 1/16	0.7~1.1
29	Plug	M24	5
41	Plug	PT 1/4	5
50	Wrench bolt	M12×35L	10
76	Plug	PT 3/8	8.5
65, 78	Wrench bolt	M8×20L	10



## 2. DISASSEMBLY

### 1) GENERAL PRECAUTIONS

- (1) Select a clean place for disassembling.  
Spread a rubber plate on a working table in order to prohibit the damage of parts.
- (2) Clean a deceleration equipment and a motor part, washing out dirt and unnecessary substances.
- (3) Without any damage of O-ring, oil seal, the adhered surface of other seals, a gear, a pin, the adhered surface of other bearings, and the surface of moisturized copper, treat each parts.
- (4) Numbers written in the parenthesis, ( ), next to the name of a part represent the part numbers of a previous page.
- (5) The side of a pipe in a motor can be written as a rear side ; the side of out-put as a front side.
- (6) In case of bonding bolts, combine a standard torque by torque wrench after spraying loctite 262 on the tab parts. (It can be dealt as assembling NPTF screws and an acceleration equipment.)

### 2) DISASSEMBLING

#### (1) Motor unit

- ① Put the motor assembly on the assemble table.

Using L-Wrench, disassemble wrench bolt (50)-8EA and so respectively disassemble shaft casing assembly and rear cover assembly.

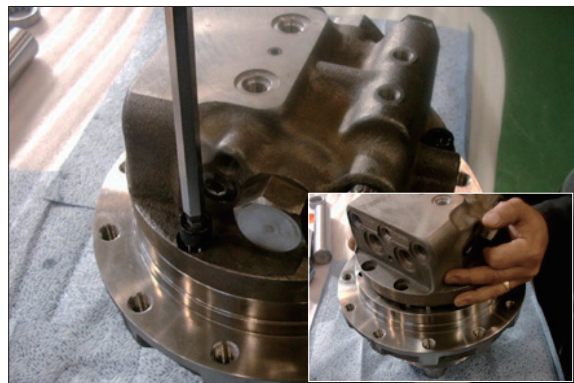

7078TM01/01A

- ② Disassemble spring (48)-8EA From shaft casing (1).

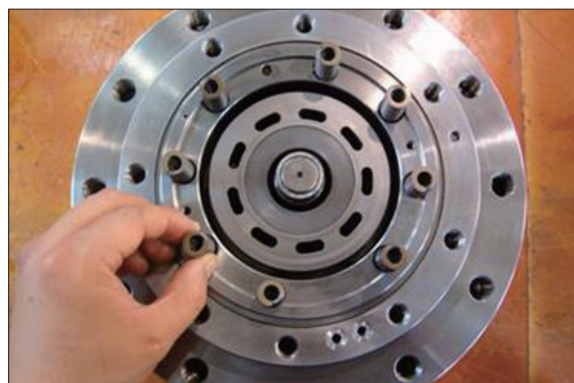

7078TM02

- ③ Using jig, disassemble parking piston (16) from shaft casing (1).



7078TM03

- ④ Disassemble O-ring (17, 19) and back up ring (18, 20) from parking piston (16)

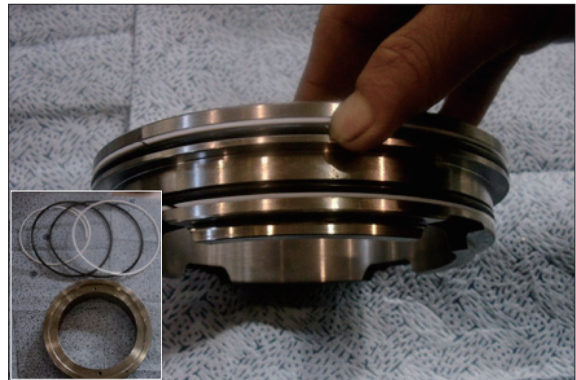

7078TM04/04A

- ⑤ Respectively in order friction plate (14), parking plate (15) disassemble from shaft casing (1).

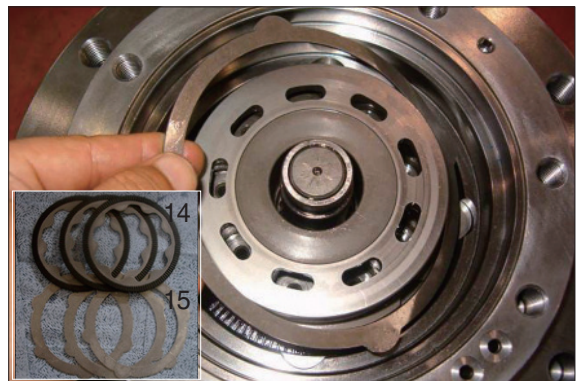

7078TM05/05A

- ⑥ Disassemble cylinder block assembly (8) from shaft casing (1).



7078TM06

## (2) Cylinder block

- ① Disassemble set plate (11), piston assembly (13) from cylinder block assembly.

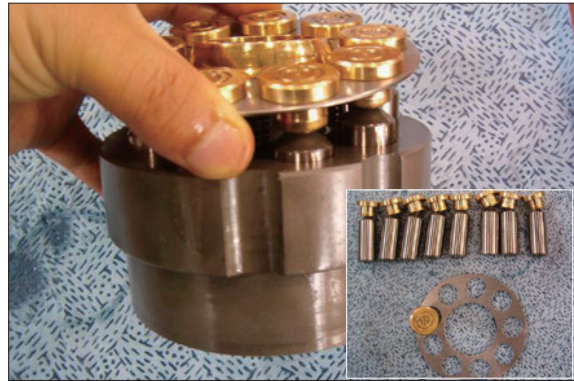

7078TM07/07A

- ② Disassembling in order cylinder block (8), ball guide (10) and spring (9).

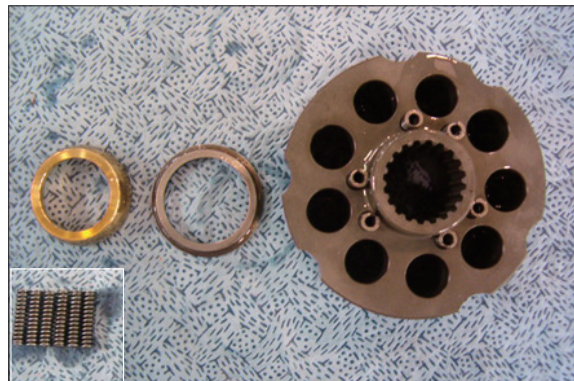

7078TM08/08A

- ③ Disassembling swash plate (7) and shaft (3) from shaft casing (1).

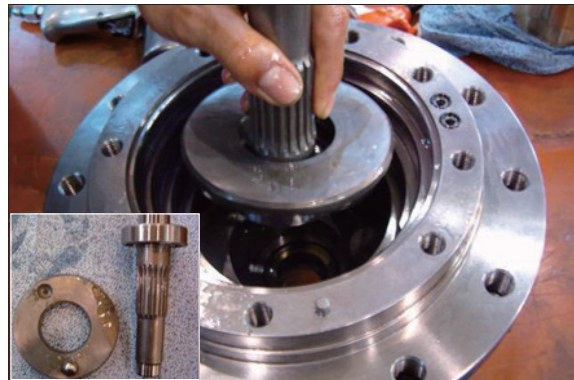

7078TM09/09A

- ④ Disassembling swash piston (5) from shaft casing (1).

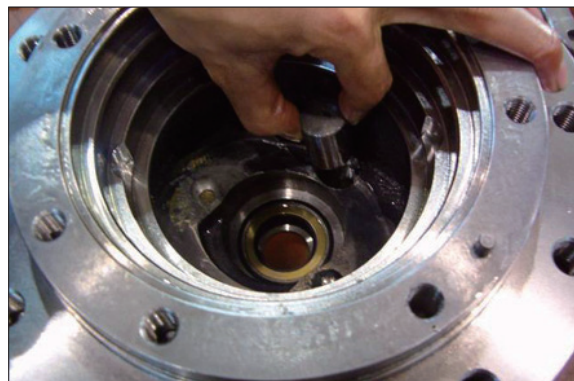

7078TM10



- ⑤ Disassembling steel ball (6) from shaft casing (1).

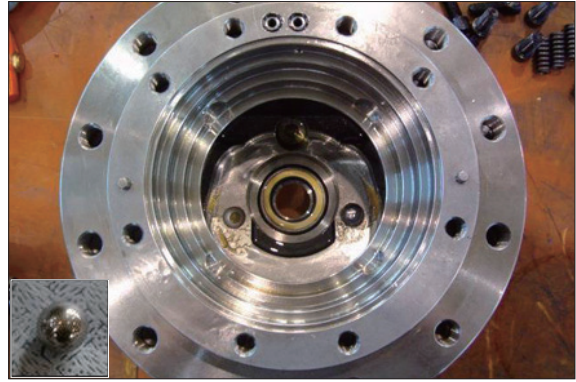

7078TM11/11A

### (3) Rear cover

- ① Disassembling valve plate (12) from rear cover (21).

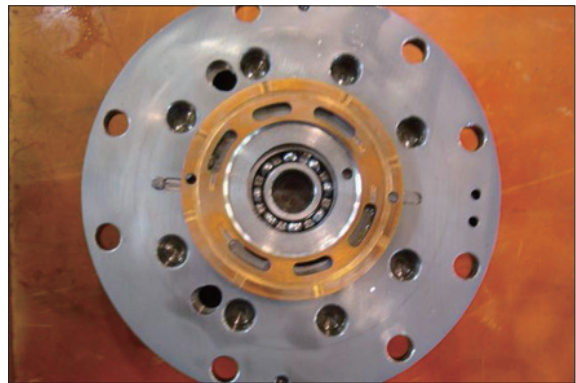

7078TM12

- ② Using plier jig, disassembling in order snap ring (26), stopper (25), spring (24), spool (23) from rear cover (21).

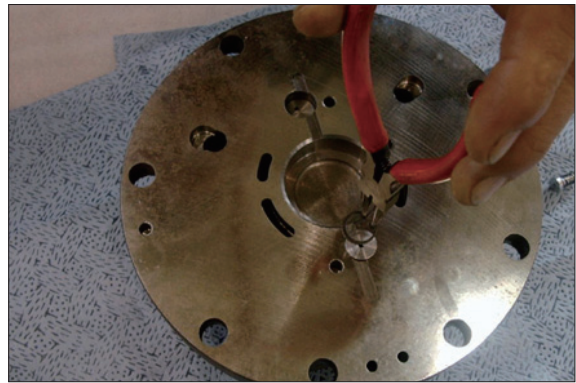

7078TM13

- ③ Using L-wrench, disassembling relief valve assembly (38) from rear cover (21).



555K7TM14/14A

- ④ Using torque wrench, disassembling plug (35) in order O-ring (36), spring 34), spring seat (33), main spool (32) from rear cover (21).

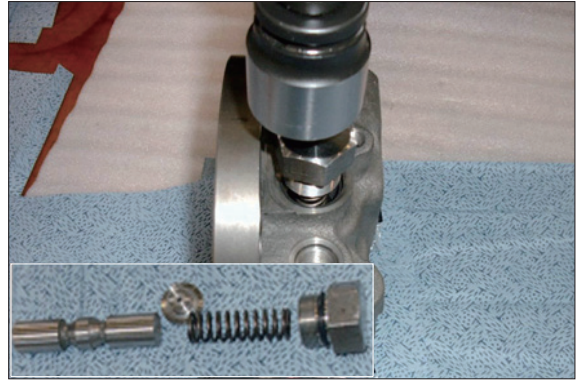

7078TM15/15A

- ⑤ Using L-wrench, disassembling plug (29) in order O-ring (30), back up ring (31), spring (28) and check (27) from rear cover (21).

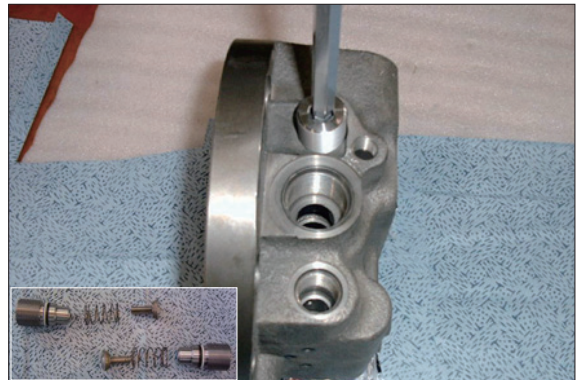

7078TM16/16A

#### (4) Reduction gear

- ① Using L-wrench, disassembling wrench bolt (78) and then ring gear cover (75), O-ring (77) from ring gear (54).



7078TM17/17A

- ② Disassembling thrust plate (74) from ring gear (54).

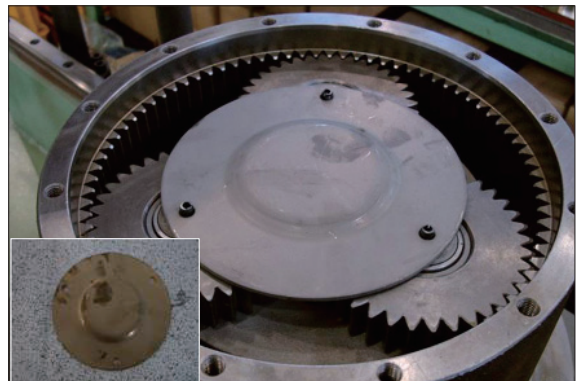

7078TM18/18A

- ③ Disassembling in order planetary gear (71), drive gear (73) from ring gear (54).

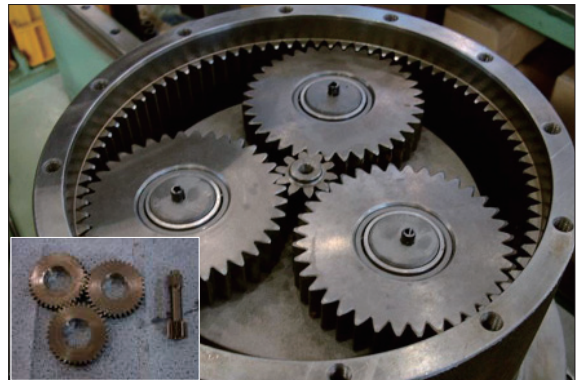

7078TM19/19A

- ④ Disassembling needle bearing (72) from ring gear (54).

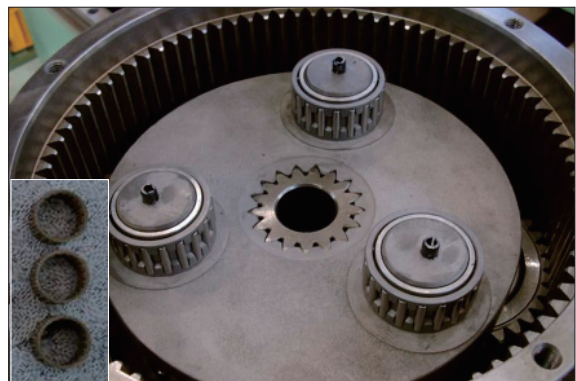

7078TM20/20A



- ⑤ Disassembling in order collar (70), carrier (68) from ring gear (54).

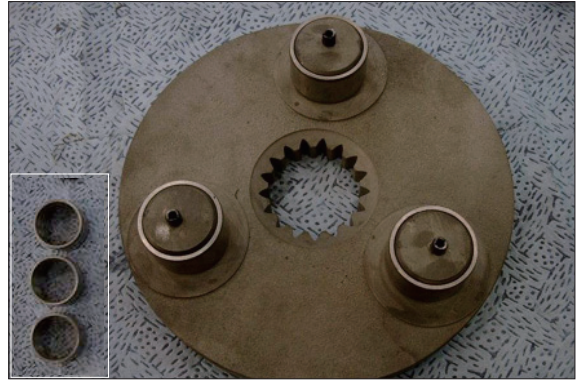

7078TM21/21A

- ⑥ Disassembling sun gear (66) from ring gear (54) and then disassembling snap ring (67) with plier jig.

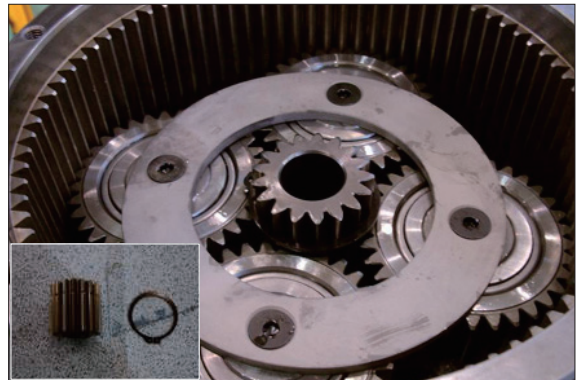

7078TM22/22A

- ⑦ Using L-wrench, disassembling plate head bolt (65)-4EA from ring gear (54) and then disassembling plate (64).

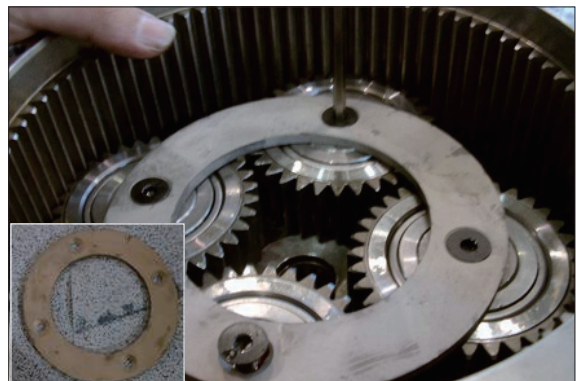

7078TM23/23A

- ⑧ Disassembling planetary gear (62)-4EA from ring gear (54).

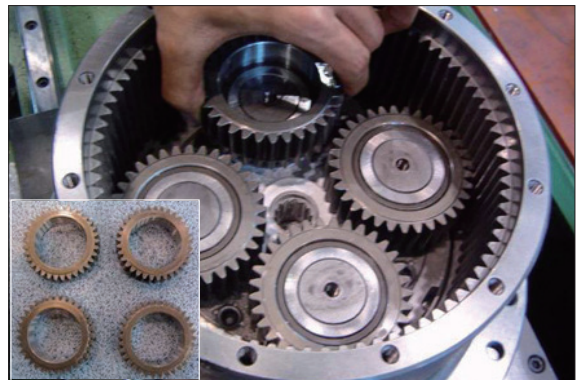

7078TM24/24A



- ⑨ Disassembling needle bearing (63)-4EA from ring gear (54).

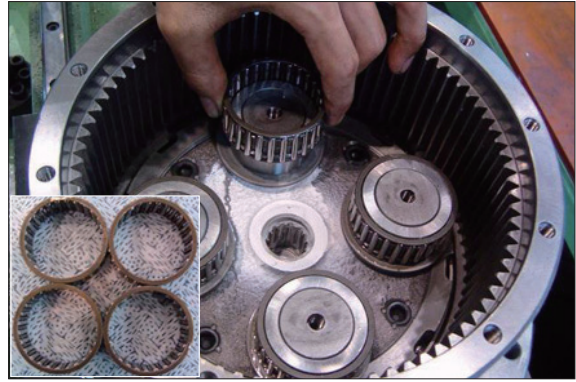

7078TM25/25A

- ⑩ Disassembling collar (61)-4EA from ring gear (54).

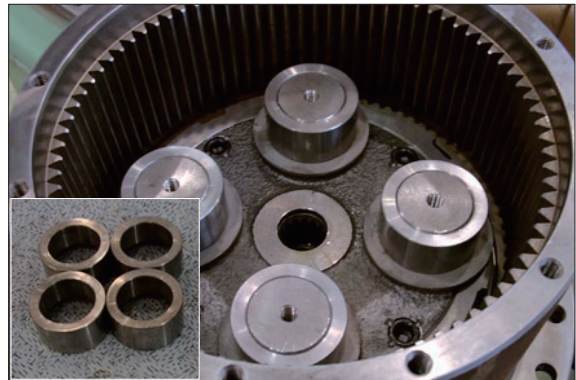

7078TM26/26A

- ⑪ Disassembling washer (60)-4EA from ring gear (54).

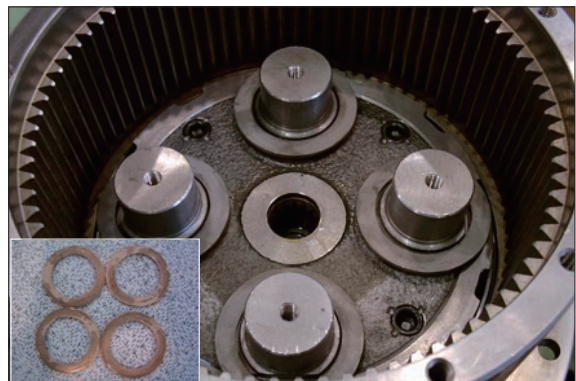

7078TM27/27A

- ⑫ Using jig, disassembling nut (59) when inner pressed state with L-wrench bolt from ring gear (54).

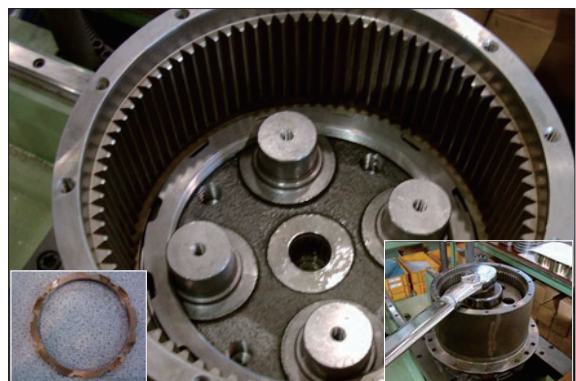

7078TM28/28A/B

- ⑬ Put the reduction gear on the assembling jig and then disassembling ring gear (54).

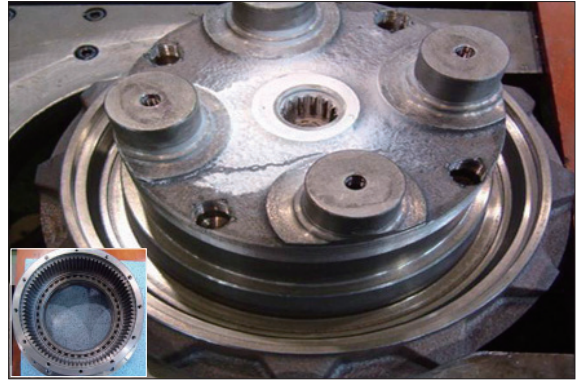

7078TM29/29A

### 3. ASSEMBLY

#### 1) GENERAL SUGGESTIONS

- (1) After washing each parts cleanly, dry it with compressed air.  
Provided that you do not wash friction plate with treated oil.
- (2) In bonding each part, fasten bond torque.
- (3) When using a hammer, do not forget to use a plastic hammer.

#### 2) ASSEMBLING

##### (1) Sub of turning axis

- ① Using a jig, insert the steel ball (56) to the shaft casing (1) and then assemble plug (57).

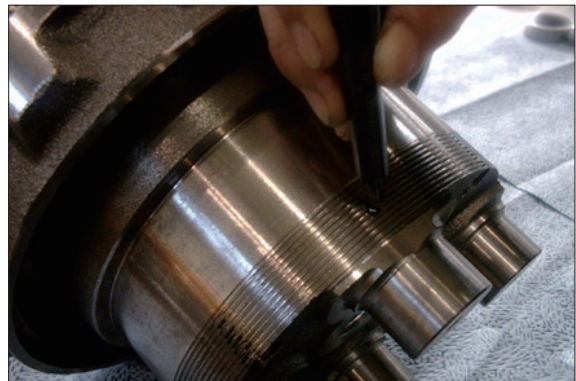

7078TM51

- ② Using a jig, assemble oil seal (2) to the shaft casing (1) and then inserting with solid hammer.

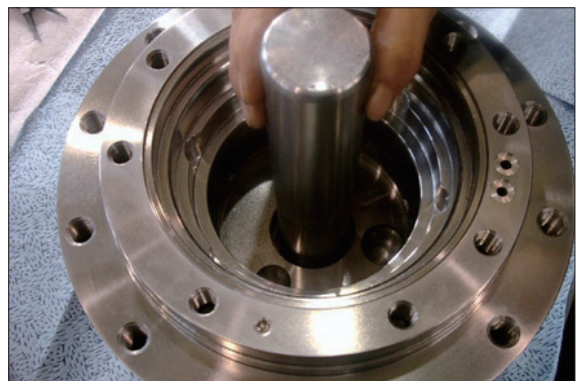

7078TM52

- ③ Assemble swash steel ball (6) to the shaft casing (1) with grease.

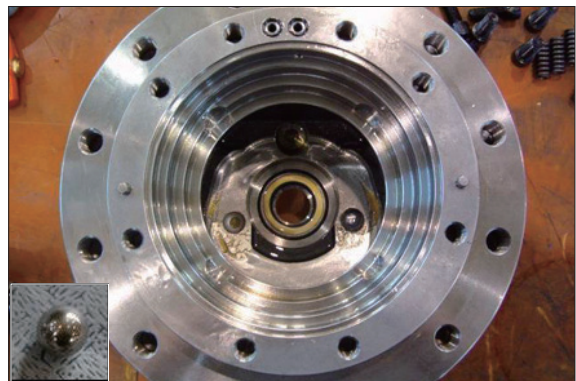

7078TM53/11A



- ④ Assemble swash piston (5) to the shaft casing (1).

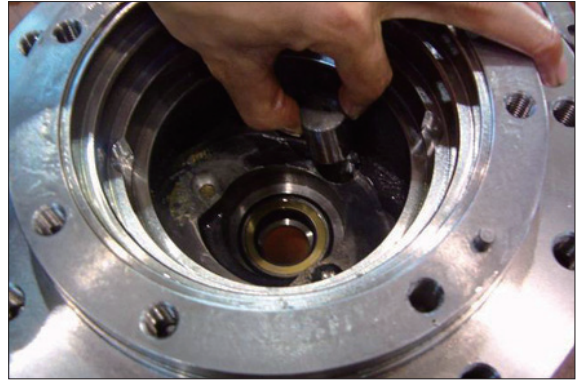

7078TM54

- ⑤ Heat pressing bearing to the shaft (3).



7078TM55

- ⑥ Assemble bearing and heat pressed shaft (3) to the shaft casing (1).



7078TM56

## (2) Cylinder block sub assembly

- ① Assemble piston assembly (13) to the set plate (11, 9 set).



7078TM57

- ② Assemble spring (9) to the cylinder block (8, 6 set).



7078TM58

- ③ Assemble ball guide (10) to the cylinder block (8).

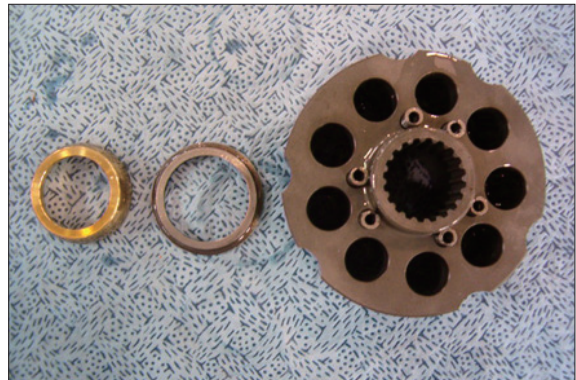

7078TM08/08A

- ④ Assemble sub-assembled piston (11, 13) to the cylinder block (8).



7078TM60

- ⑤ Assemble cylinder block (8) to the shaft casing (1).



7078TM06



- ⑥ Assembling friction plate (14), parking plate (15) (respectively 3EA assembling) to the shaft casing (1).

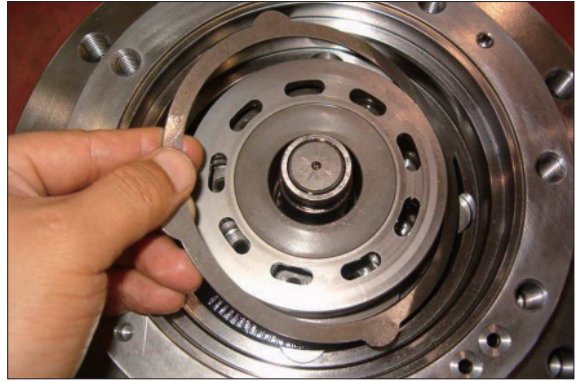

7078TM05

- ⑦ Assembling back up ring (18), O-ring (17, 19), back up ring (20) to the parking piston (16).

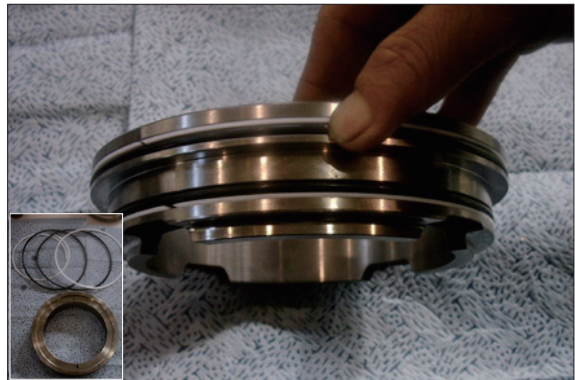

7078TM04/04A

- ⑧ Using a jig, insert the parking piston to the shaft casing (1) and assemble.

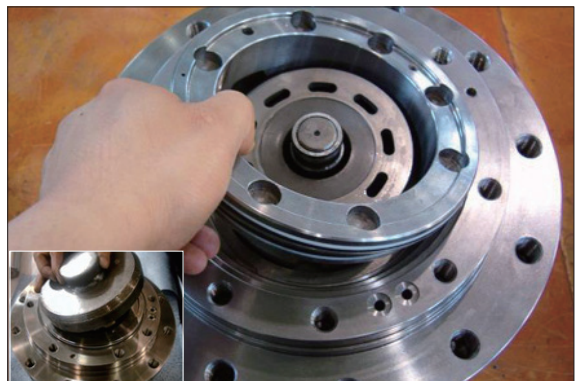

7078TM64/64A

- ⑨ Assemble spring (48) to the shaft casing (1) and then assemble O-ring (49).

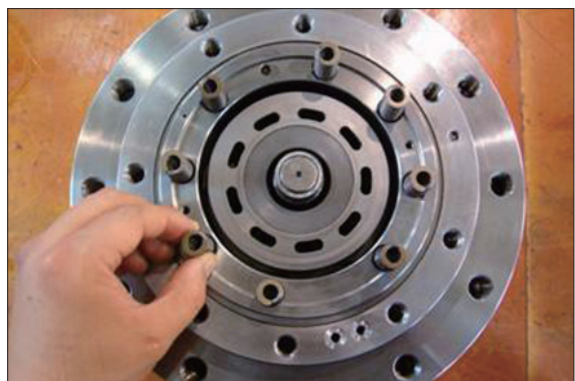

7078TM02



### (3) Rear cover assembly

- ① Using a L-Wrench, assemble plug (22) 10EA to the rear cover (21).



7078TM66

- ② Assemble in order steel ball (39), check-seat (40) and plug (41) to the rear cover (21).

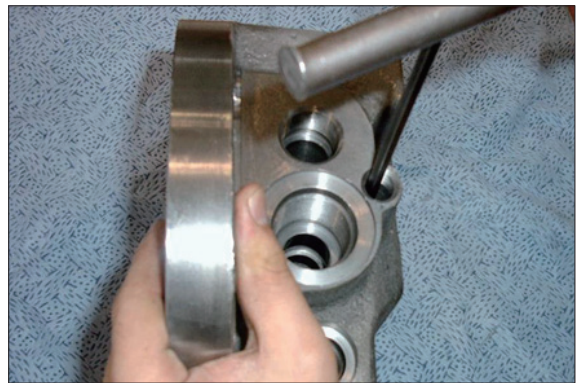

7078TM67

- ③ Assemble plug (42, 44), O-ring (43) to the rear cover (21).

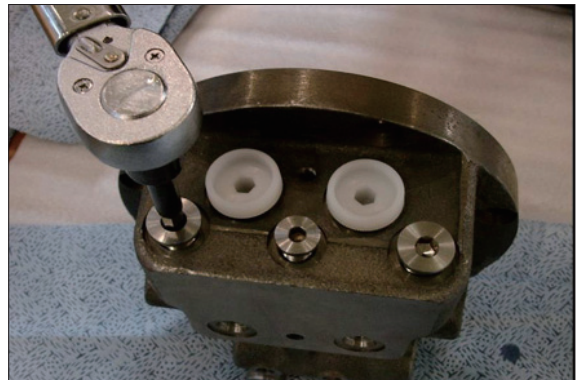

7078TM68

- ④ Assemble check (27), spring (28) to rear cover (21) and assemble back up ring (31), O-ring (30) to the plug (29) after then using L-Wrench.

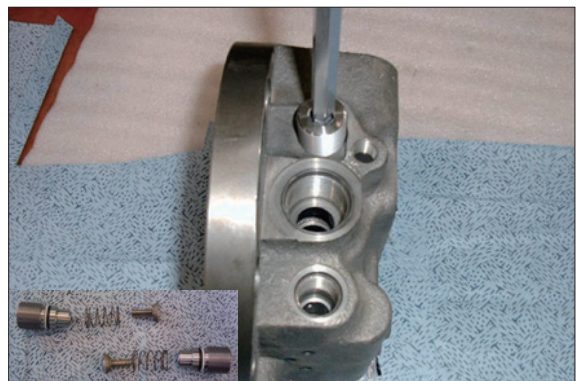

7078TM16/16A

- ⑤ Insert main spool (32), spring-seat (33), spring (34) to the rear cover (21) and assemble plug (35) with L-wrench.

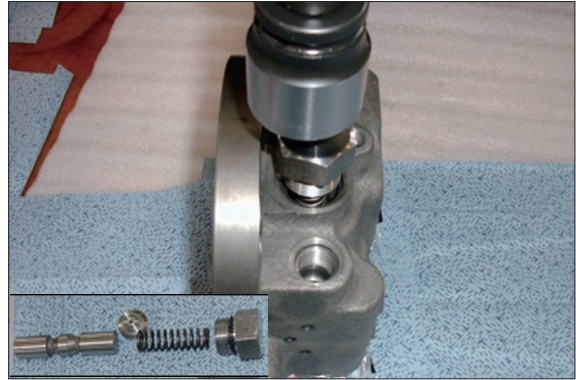

7078TM15/15A

- ⑥ Assemble relief valve assembly (38) (with left-right symmetry) to the rear cover (21) and then tighten with a torque wrench.



7078TM71

- ⑦ Using a plier jig, assemble snap ring (26), stopper (25), spring (24), spool (23) to the rear cover.

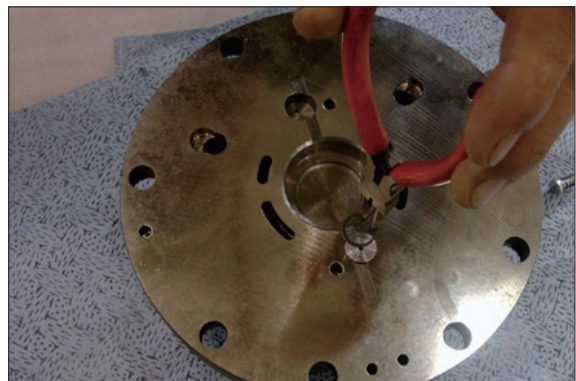

7078TM13

- ⑧ Assemble roller bearing (45), pin (46) and valve plate (12) to the rear cover (21).

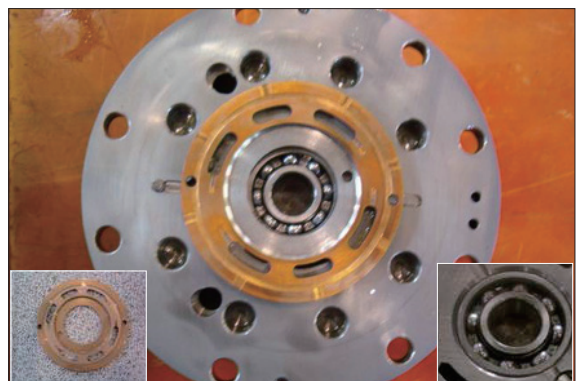

7078TM12/73/73A



- ⑨ Combine rear cover assembly and shaft casing assembly with bolt (50).



7078TM74

#### (4) Travel reduction gear

- ① Before assembling nut (59) to the motor. Eliminate burr and alien substances ready for assembling.

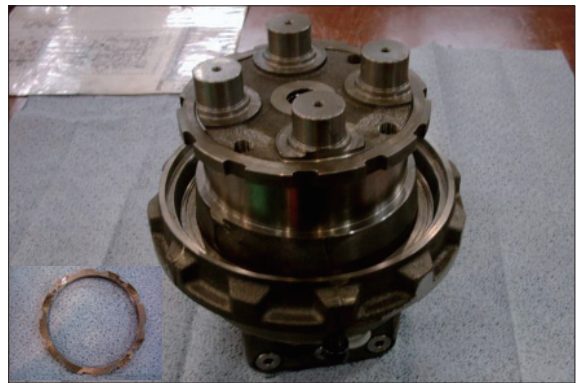

7078TM77/28A

- ② Insert ring gear (54) to the spray washing M/C and heat 69°C ~70°C one minute.



7078TM78

- ③ Assembling angular bearing (55) to the ring gear (54).



7078TM79/79A

- ④ Insert steel ball (56) 105EA to the ring gear (54) with a jig after assembling plug (57) 2EA with L-Wrench.



7078TM80/80A

- ⑤ Assemble floating seal (58) to ring gear (54) and motor part with a jig.

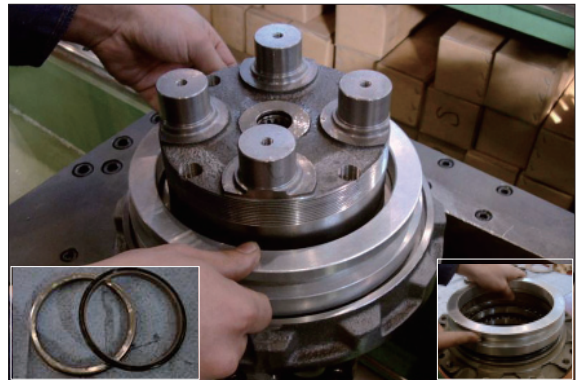

7078TM81/81A/82

- ⑥ Upset the ring gear (54) and assemble with motor.



7078TM83

- ⑦ Combine nut (59) to the ring gear (54) and pressing use a jig and then assembling with torque-wrench.



7078TM28/28B/28C



- ⑧ Using a L-wrench, assembling plug-4EA to the ring gear (54) and then cocking by a jig.

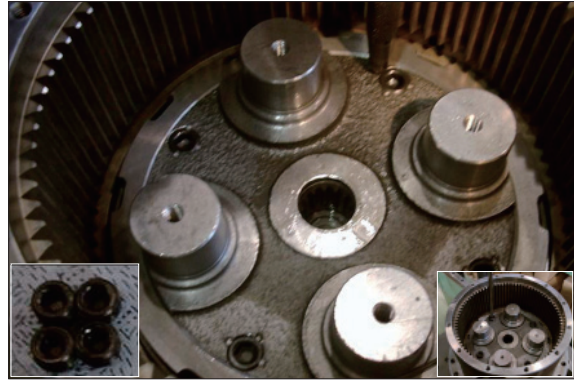

- ⑨ Assemble washer (60)-4EA the ring gear (54).

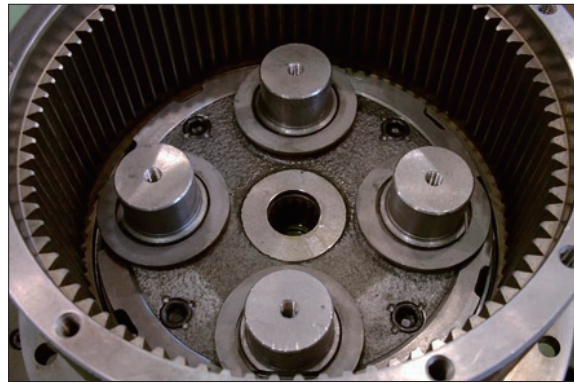

- ⑩ Assemble collar (61)-4EA to the ring gear (54).

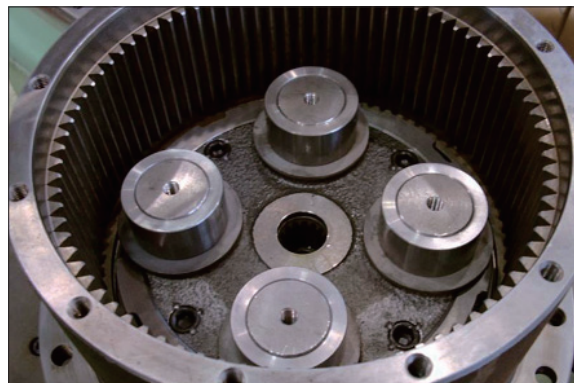

- ⑪ Assemble needle bearing (63)-4EA to the ring gear (54).

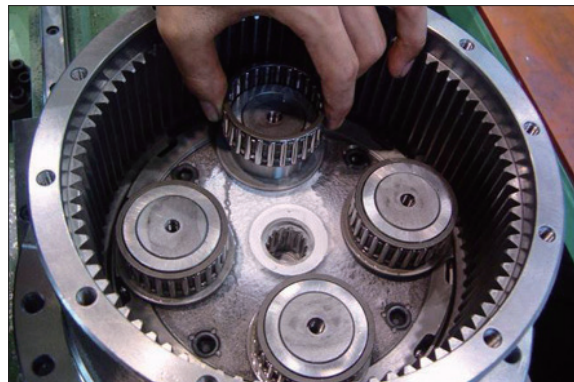



- ⑫ Assemble planetary gear (62)-4EA to the ring gear (54).

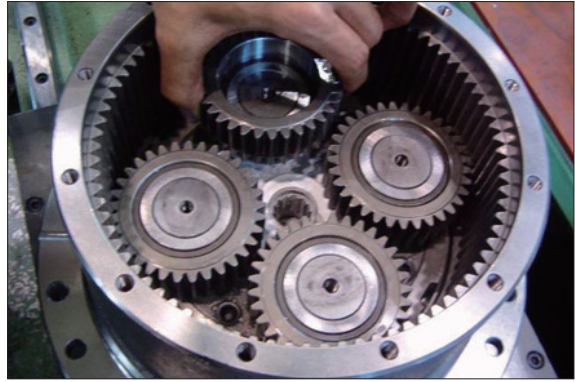

7078TM24

- ⑬ Assemble plate (64)-1EA to the ring gear (54) and then combine plate head bolt (65)-4EA with L-wrench. (after paste loctite and then combine the plate head bolt).

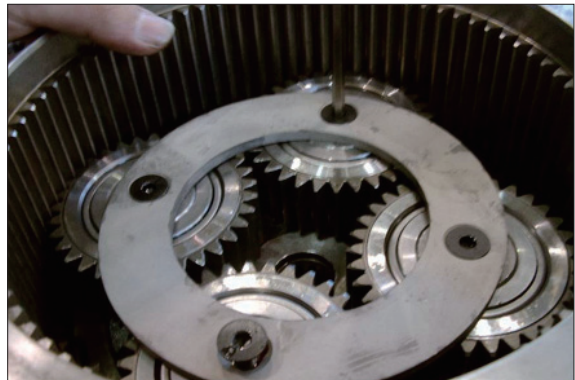

7078TM23

- ⑭ Assembling snap ring (67) to the sun gear (66) with a plier jig.

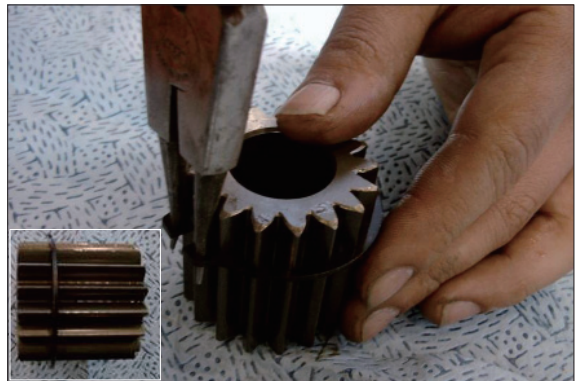

7078TM86/86A

- ⑮ Assemble sun gear with snap ring assembly to the ring gear (54).

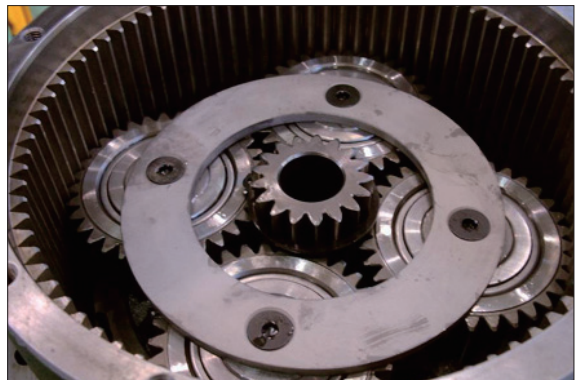

7078TM22

- ⑩ Assemble in order collar (70), spring pin (69) to the carrier (68).

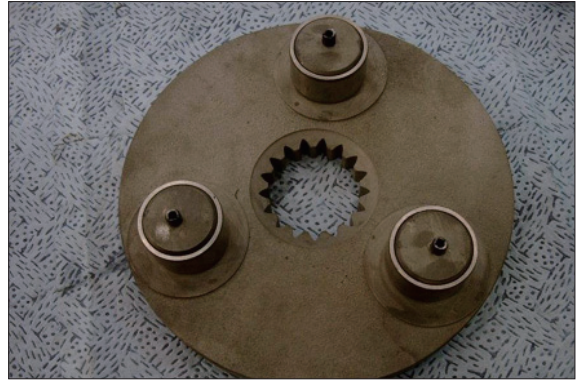

7078TM21

- ⑪ Assemble carrier sub assembly to the ring gear (54).

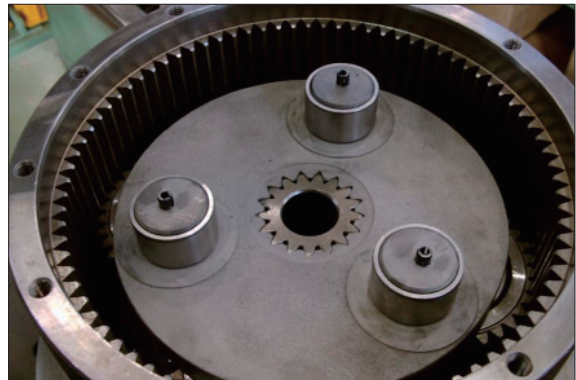

7078TM87

- ⑫ Assemble needle bearing (72)-3EA to the ring gear (54).

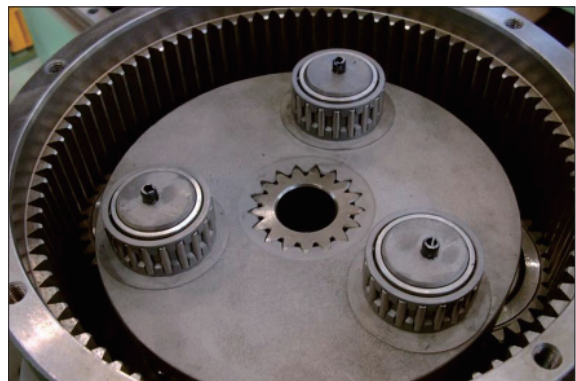

7078TM20

- ⑬ Assemble in order planetary gear (71), drive gear (73) to the ring gear (54).

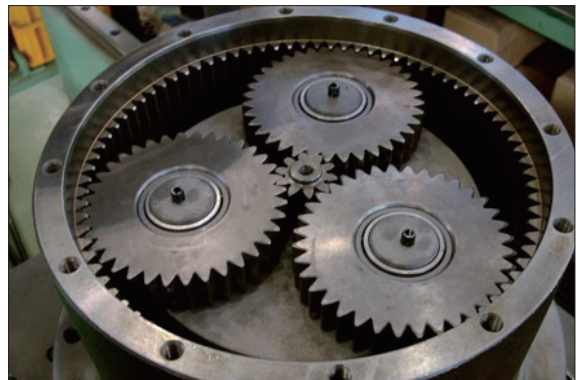

7078TM19

- ⑳ Assemble thrust plate (74) to the ring gear (54).

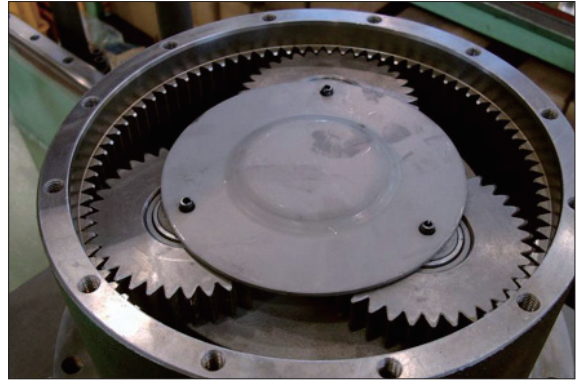

7078TM18

- ㉑ Assemble in order ring gear cover (75) with O-ring (77) and then assemble wrench bolt (78) with torque-wrench.



7078TM17/17A

- ㉒ Roll the tarpon tape to the ring gear (54) and then combine with L-wrench(after test of drain part water pressure and capacity and then assemble plug PT3/8 form).



7078TM88



**(5) Test**

**① Motor water pressure test**

-Check the oil leak for one minute by appearance test at air pressure 5 kgf/cm<sup>2</sup>.

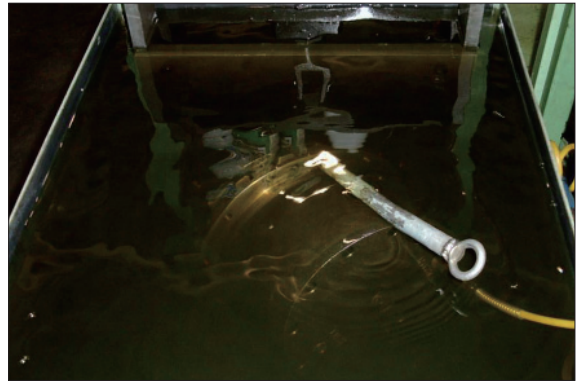

7078TM89

**② Performance test**

-Pour the gear oil (80W-90) by beaker at the reduction gear.



7078TM90

**③ Test bench mounting**

-Partially performance test by mounting motor test bench.

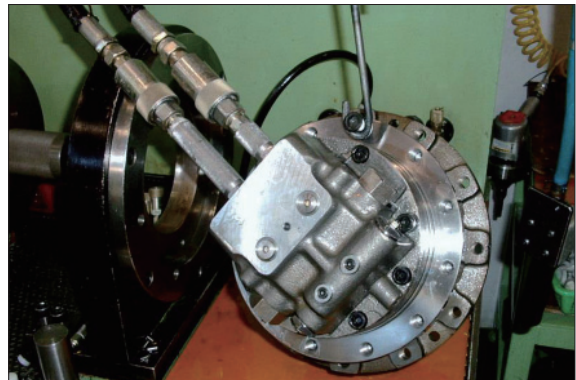

7078TM91

## GROUP 7 RCV LEVER

### 1. REMOVAL AND INSTALL

#### 1) REMOVAL

- (1) Lower the work equipment to the ground and stop the engine.
- (2) Operate the control levers and pedals several times to release the remaining pressure in the hydraulic piping.
- (3) Loosen the breather slowly to release the pressure inside the hydraulic tank.

▲ **Escaping fluid under pressure can penetrate the skin causing serious injury.**

- (4) Loosen the socket bolt (1).
  - (5) Remove the cover of the console box.
  - (6) Disconnect pilot line hoses (3).
  - (7) Remove the pilot valve assembly (2).
- ※ **When removing the pilot valve assembly, check that all the hoses have been disconnected.**

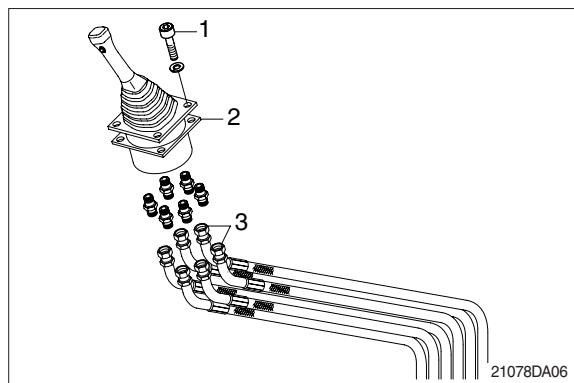

#### 2) INSTALL

- (1) Carry out installation in the reverse order to removal.
- (2) Confirm the hydraulic oil level and check the hydraulic oil leak or not.



## 2. DISASSEMBLY AND ASSEMBLY

### 1) STRUCTURE

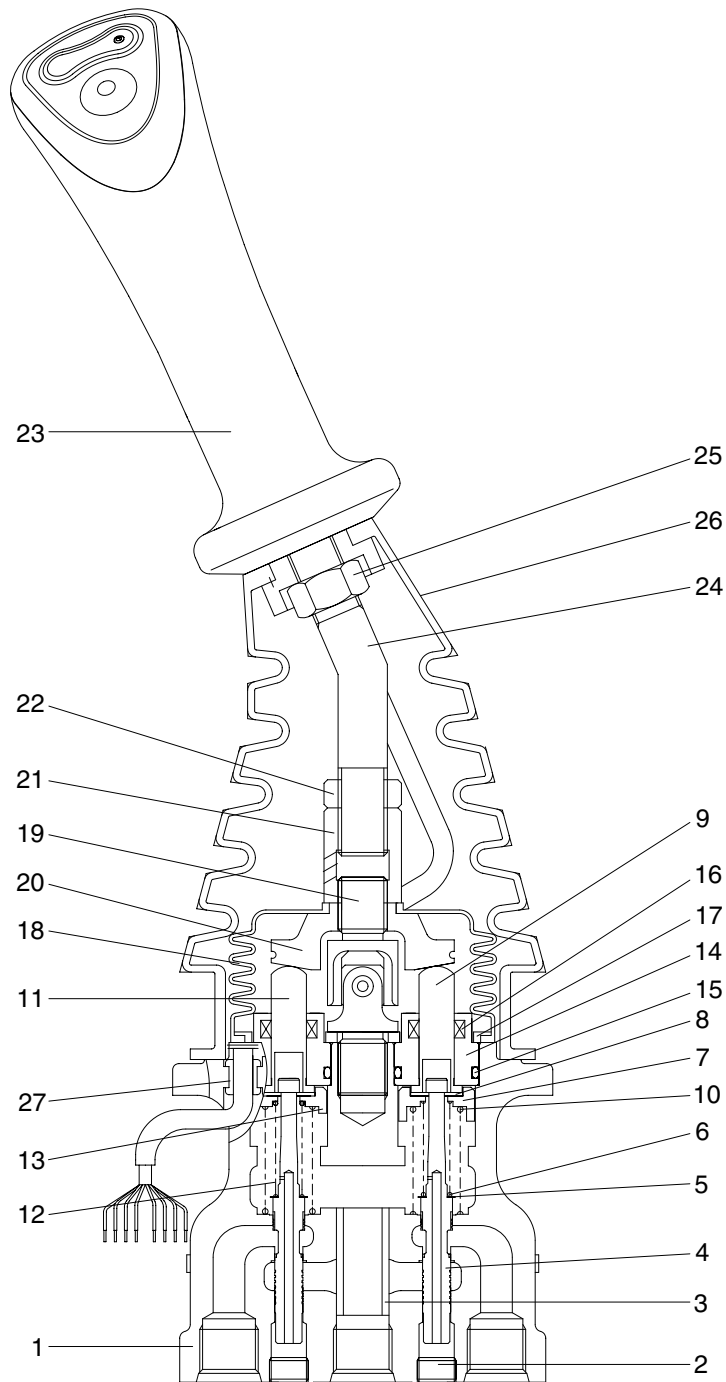

555C92RL02

1	Case	8	Stopper	15	O-ring	22	Lock nut
2	Plug	9	Push rod	16	Rod seal	23	Handle assembly
3	Bushing	10	Spring	17	Plate	24	Handle bar
4	Spool	11	Push rod	18	Boot	25	Nut
5	Shim	12	Spring	19	Joint assembly	26	Boot
6	Spring	13	Spring seat	20	Swash plate	27	Bushing
7	Spring seat	14	Plug	21	Adjusting nut		

## 2) TOOLS AND TIGHTENING TORQUE

### (1) Tools

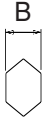
Tool name	Remark	
Allen wrench	6	
Spanner	22	
	27	
(+) Driver	Length 150	
(-) Driver	Width 4~5	
Torque wrench	Capable of tightening with the specified torques	

### (2) Tightening torque

Part name	Item	Size	Torque	
			kgf · m	lbf · ft
Plug	2	PT 1/8	3.0	21.7
Joint	18	M14	3.5	25.3
Swash plate	19	M14	5.0±0.35	36.2±2.5
Adjusting nut	20	M14	5.0±0.35	36.2±2.5
Lock nut	21	M14	5.0±0.35	36.2±2.5
Screw	29	M 3	0.05	0.36

### 3) DISASSEMBLY

(1) Clean pilot valve with kerosene.

※ Put blind plugs into all ports

(2) Fix pilot valve in a vise with copper (or lead) sheets.

(3) Remove end of boot (26) from case (1) and take it out upwards.

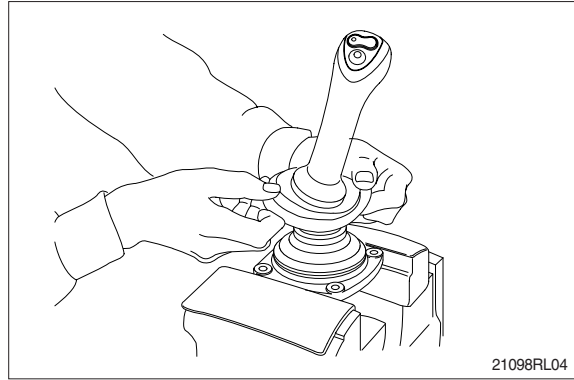

※ For valve with switch, remove cord also through hole of casing.

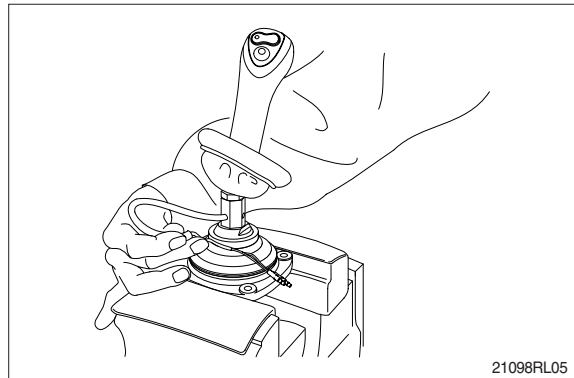

(4) Loosen lock nut (22) and adjusting nut (21) with spanners on them respectively, and take out handle section as one body.

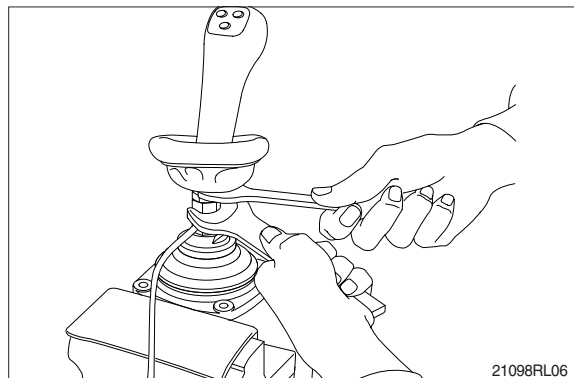

(5) Remove the boot (18).

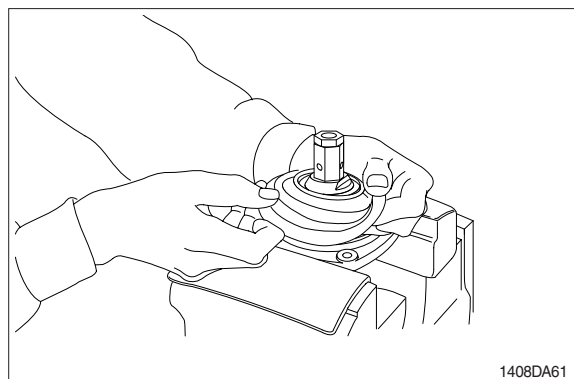

- (6) Loosen adjusting nut (21) and plate (20) with spanners on them respectively, and remove them.

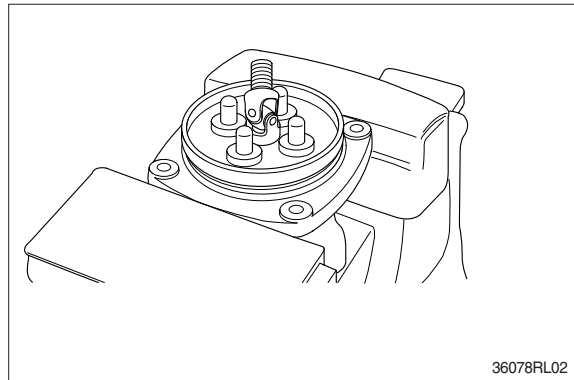
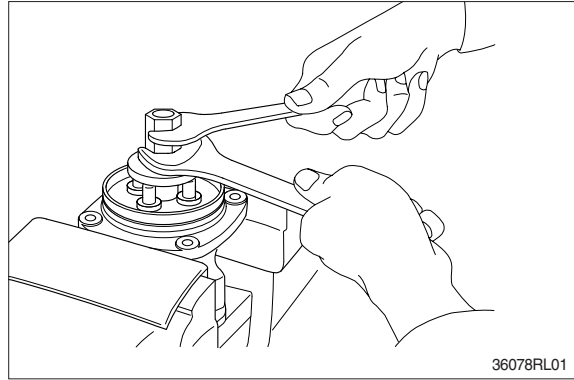

- (7) Turn joint anticlockwise to loosen it, utilizing jig (special tool).  
※ When return spring (10) is strong in force, plate (17), plug (14) and push rod (11) will come up on loosening joint. Pay attention to this.

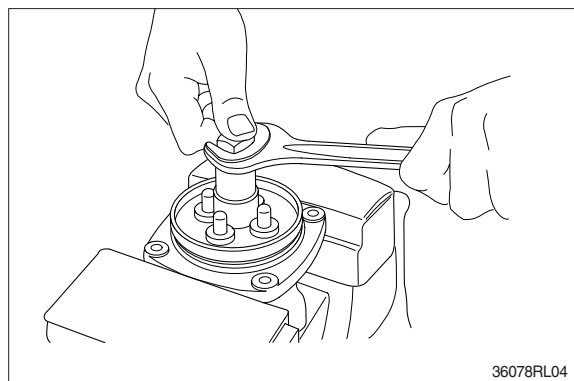
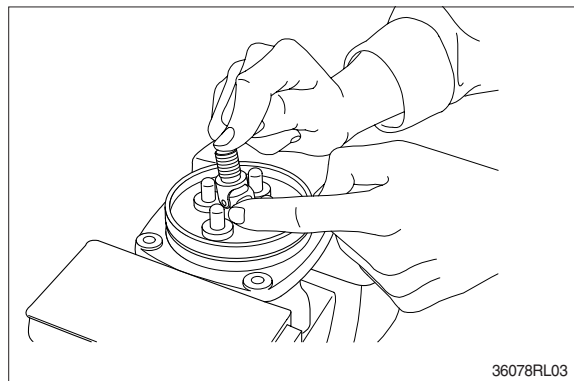

(8) Remove plate (17).

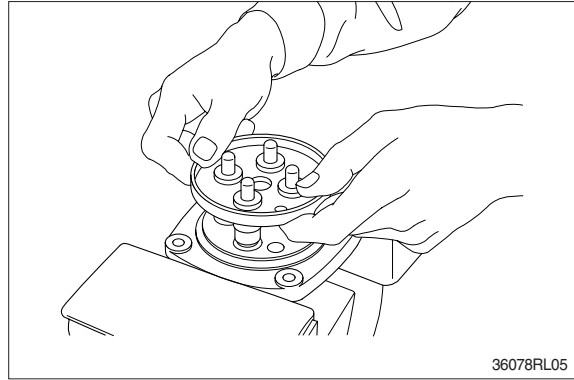

(9) When return spring (10) is weak in force, plug (14) stays in casing because of sliding resistance of O-ring.

- ※ Take it out with minus screwdriver. Take it out, utilizing external periphery groove of plug and paying attention not to damage it by partial loading.
- ※ During taking out, plug may jump up due to return spring (10) force. Pay attention to this.

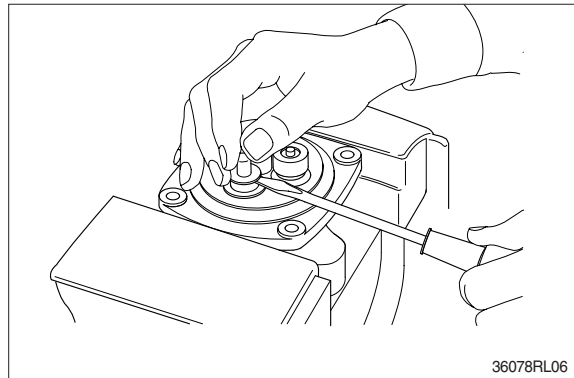

(10) Remove reducing valve subassembly and return spring (10) out of casing.

- ※ Record relative position of reducing valve subassembly and return springs.

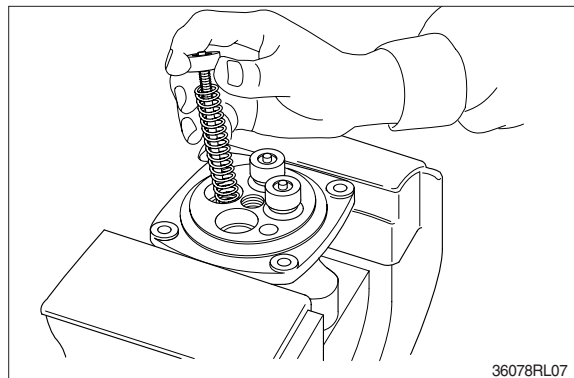

(11) Loosen hexagon socket head plug (2) with hexagon socket screw key.

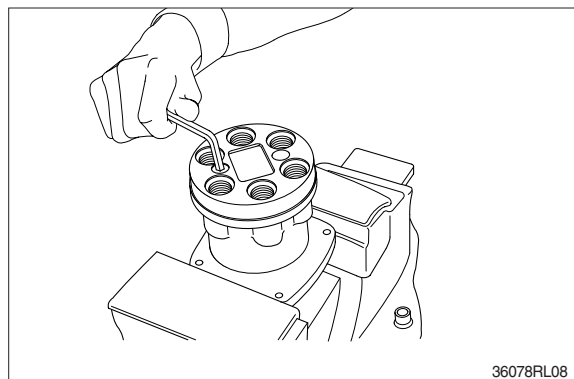



(12) For disassembling reducing valve section, stand it vertically with spool (4) bottom placed on flat workbench. Push down spring seat (7) and remove two pieces of semicircular stopper (8) with tip of small minus screwdriver.

- ※ Pay attention not to damage spool surface.
- ※ Record original position of spring seat (7).
- ※ Do not push down spring seat more than 6 mm.

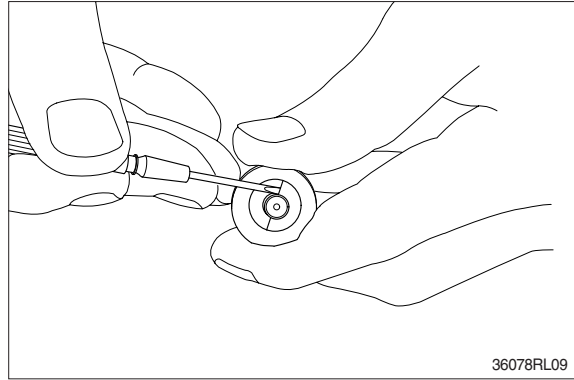

(13) Separate spool (4), spring seat (7), spring (6) and shim (5) individually.

- ※ Until being assembled, they should be handled as one subassembly group.

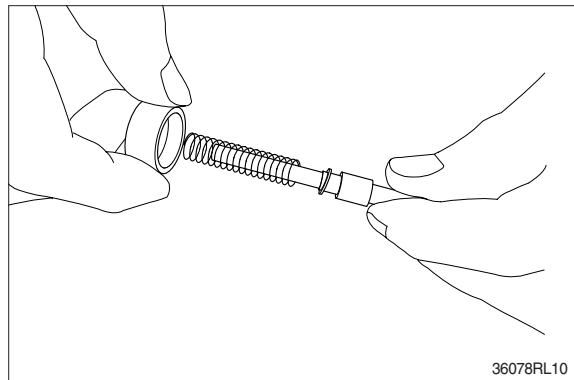

(14) Take push rod (14) out of plug (11).

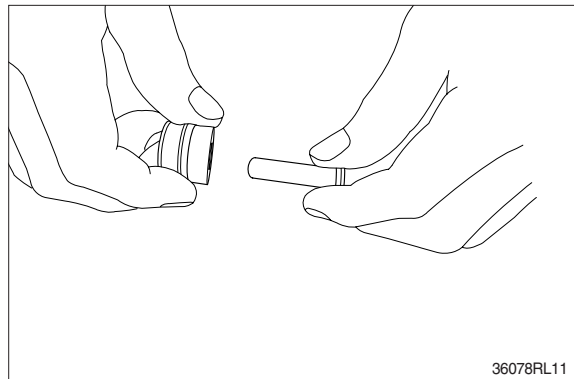

(15) Remove O-ring (15) and seal (16) from plug (14).

Use small minus screwdriver or so on to remove this seal.

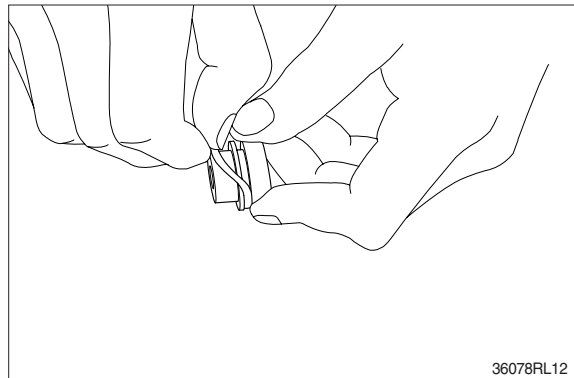

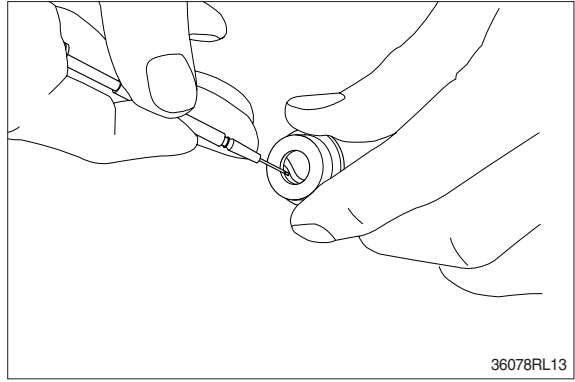

(16) Remove lock nut (22) and then boot (26).

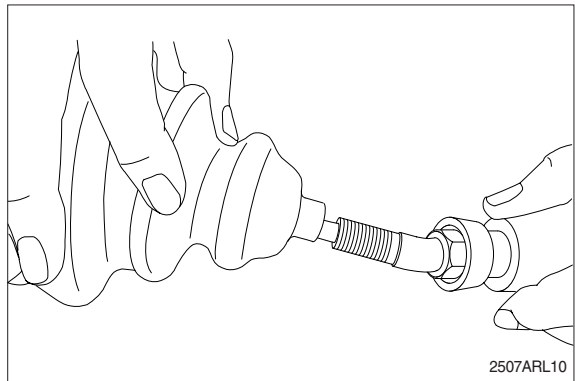
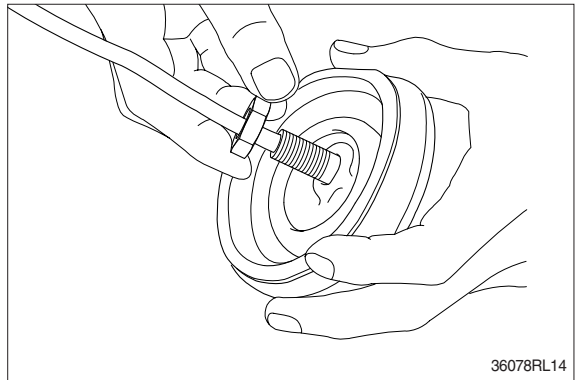

### **(17) Cleaning of parts**

- ① Put all parts in rough cleaning vessel filled with kerosene and clean them (rough cleaning).
  - ※ If dirty part is cleaned with kerosene just after putting it in vessel, it may be damaged. Leave it in kerosene for a while to loosen dust and dirty oil.
  - ※ If this kerosene is polluted, parts will be damaged and functions of reassembled valve will be degraded.  
Therefore, control cleanliness of kerosene fully.
- ② Put parts in final cleaning vessel filled with kerosene, turning it slowly to clean them even to their insides (finish cleaning).
  - ※ Do not dry parts with compressed air, since they will be damaged and/or rusted by dust and moisture in air.

### **(18) Rust prevention of parts.**

- Apply rust-preventives to all parts.
- ※ If left as they are after being cleaned, they will be rusted and will not display their functions fully after being reassembled.

#### 4) ASSEMBLY

(1) Tighten hexagon socket head plug (2) to the specified torque.

※ Tighten two bolts alternately and slowly.

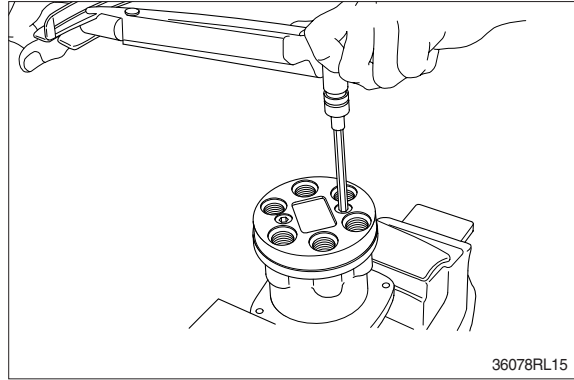

(2) Put shim (5), springs (6) and spring seat (7) onto spool (4) in this order.

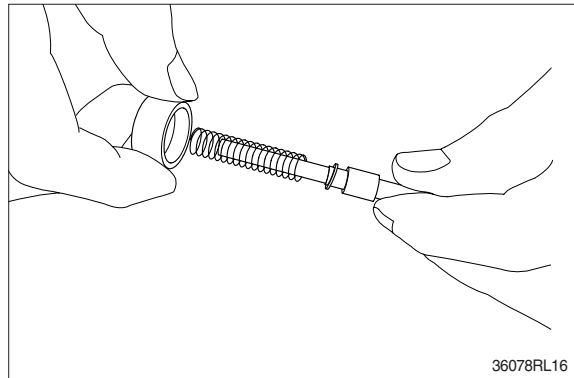

(3) Stand spool vertically with its bottom placed on flat workbench, and with spring seat pushed down, put two pieces of semicircular stopper (8) on spring seat without piling them on.

※ Assemble stopper (8) so that its sharp edge side will be caught by head of spool. Do not push down spring seat more than 6 mm.

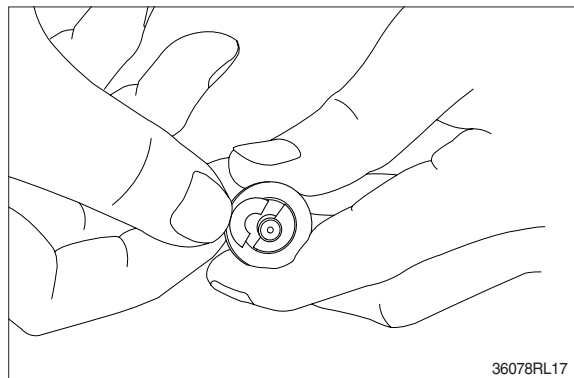

(4) Assemble spring (10) into casing (1). Assemble reducing valve subassembly into casing.

※ Assemble them to their original positions.

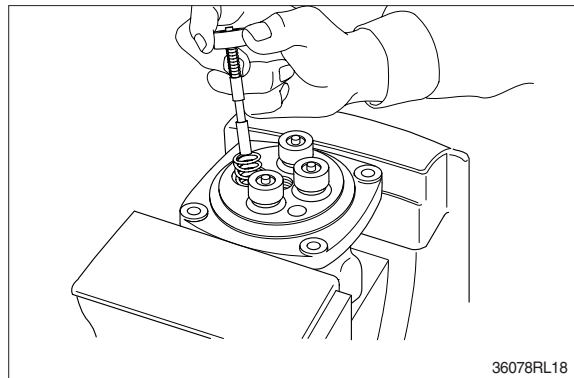

(5) Assemble O-ring (15) onto plug (14).

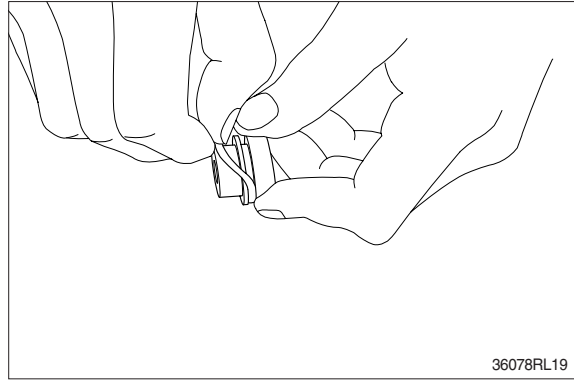

(6) Assemble seal (16) to plug (14).

※ Assemble seal in such lip direction as shown below.

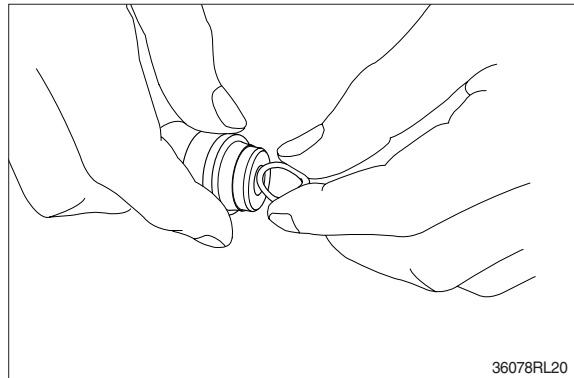

(7) Assemble push rod (11) to plug (14).

※ Apply working oil on push-rod surface.

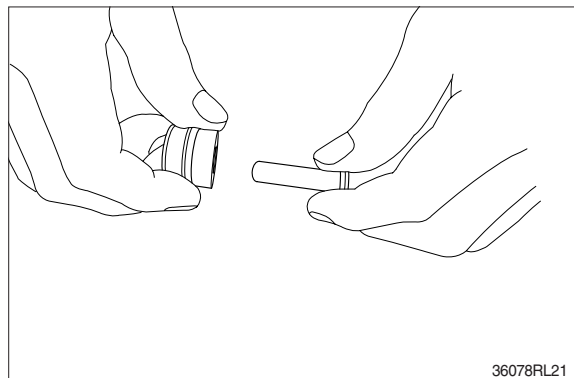

(8) Assemble plug subassembly to casing.

※ When return spring is weak in force, subassembly stops due to resistance of O-ring.

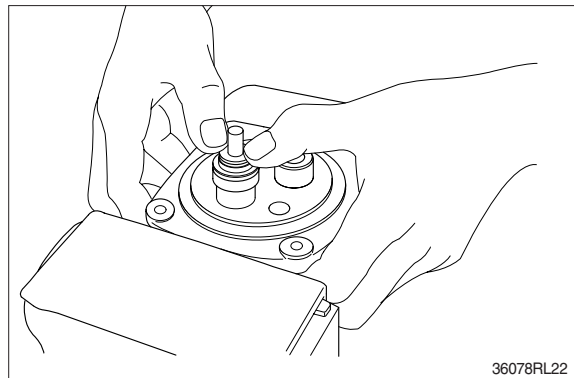



- (9) When return spring is strong in force, assemble 4 sets at the same time, utilizing plate (17), and tighten joint (19) temporarily.

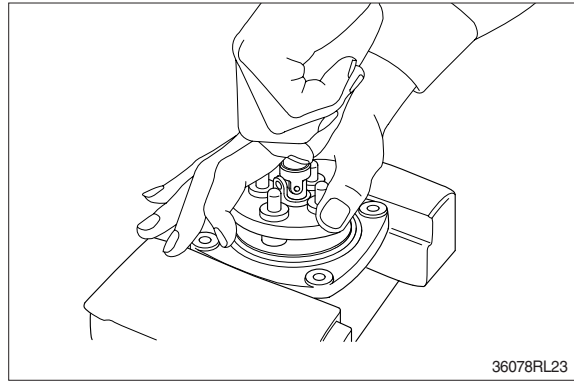

- (10) Fit plate (17).

- (11) Tighten joint (19) with the specified torque to casing, utilizing jig.

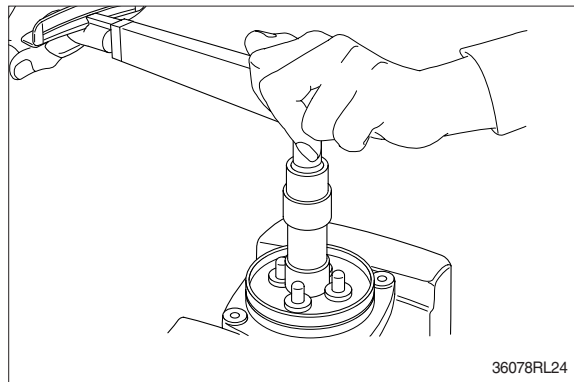

- (12) Assemble plate (20) to joint (19).

- ※ Screw it to position that it contacts with 4 push rods evenly.
- ※ Do not screw it over.

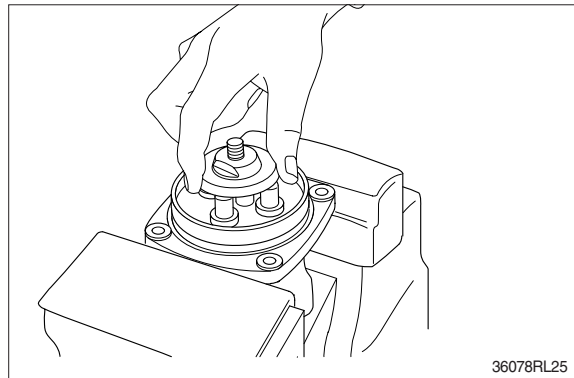

- (13) Assemble adjusting nut (21), apply spanner to width across flat of swash plate (20) to fix it, and tighten adjusting nut to the specified torque.

- ※ During tightening, do not change position of disk.

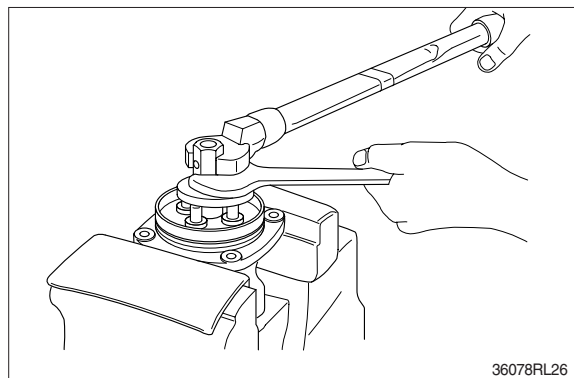

(14) Fit boot (18) to plate.

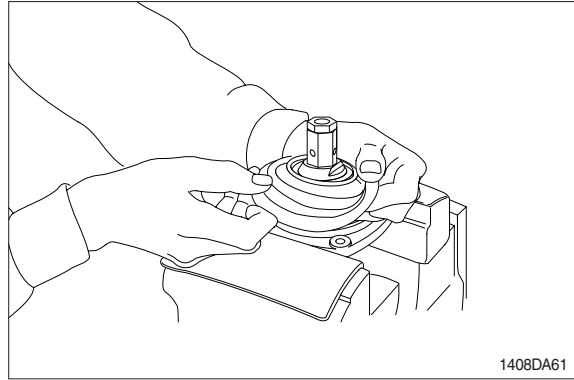

(15) Fit boot (26) and lock nut (22), and handle subassembly is assembled completely.

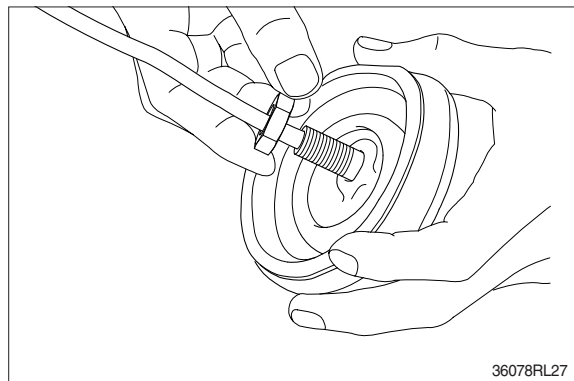
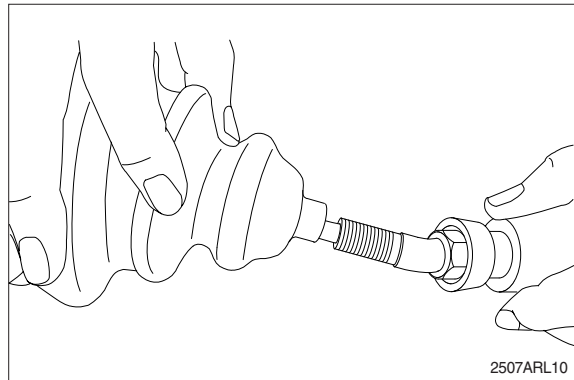

(16) Pull out cord and tube through adjusting nut hole provided in direction  $60^{\circ}$  to  $120^{\circ}$  from casing hole.

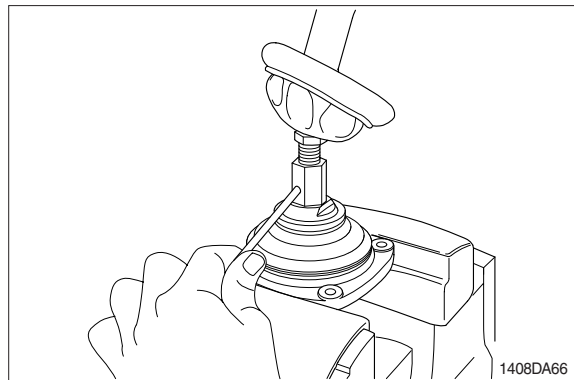

- (17) Assemble bushing (27) to plate and pass cord and tube through it.  
※ Provide margin necessary to operation.

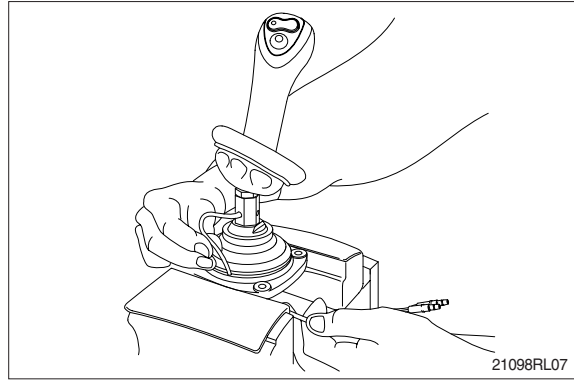

- (18) Determine handle direction, tighten lock nut (22) to specified torque to fix handle.

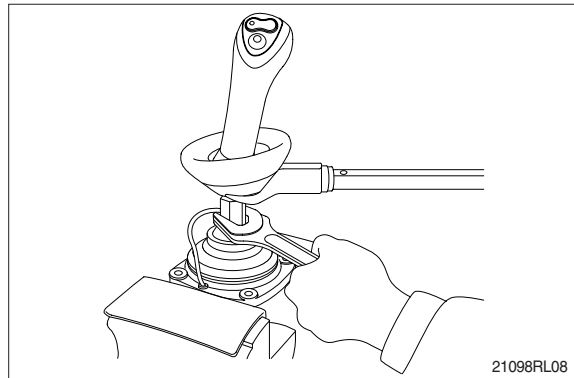

- (19) Apply grease to rotating section of joint and contacting faces of disk and push rod.

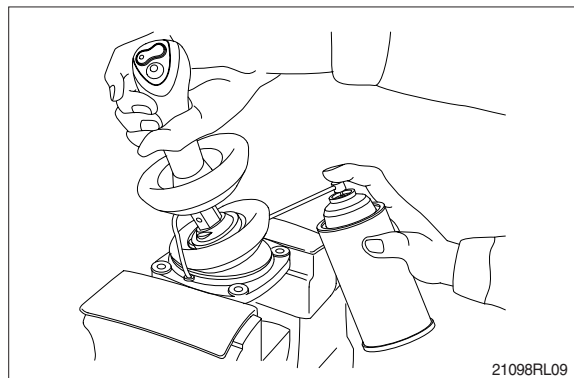

- (20) Assemble lower end of bellows to casing.  
(21) Inject volatile rust-preventives through all ports and then put blind plugs in ports.

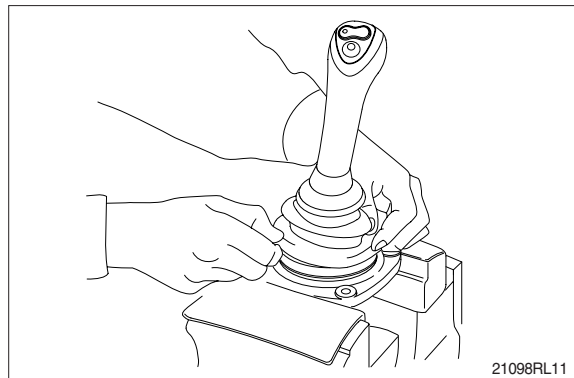

## GROUP 8 TURNING JOINT

### 1. REMOVAL AND INSTALL

#### 1) REMOVAL

- (1) Lower the work equipment to the ground and stop the engine.
- (2) Operate the control levers and pedals several times to release the remaining pressure in the hydraulic piping.
- (3) Loosen the breather slowly to release the pressure inside the hydraulic tank.

**▲ Escaping fluid under pressure can penetrate the skin causing serious injury.**

※ When pipes and hoses are disconnected, the oil inside the piping will flow out, so catch it in oil pan.

- (4) Disconnect all hoses.
- (5) Sling the turning joint assembly (1) and remove the mounting bolt (2).
  - Weight : 30 kg (70 lb)
  - Tightening torque :  $12.3 \pm 1.3 \text{ kgf} \cdot \text{m}$   
( $88.9 \pm 9.4 \text{ lbf} \cdot \text{ft}$ )

- (6) Remove the turning joint assembly.
  - ※ When removing the turning joint, check that all the hoses have been disconnected.

#### 2) INSTALL

- (1) Carry out installation in the reverse order to removal.
  - ※ Take care of turning joint direction.
  - ※ Assemble hoses to their original positions.
  - ※ Confirm the hydraulic oil level and check the hydraulic oil leak or not.

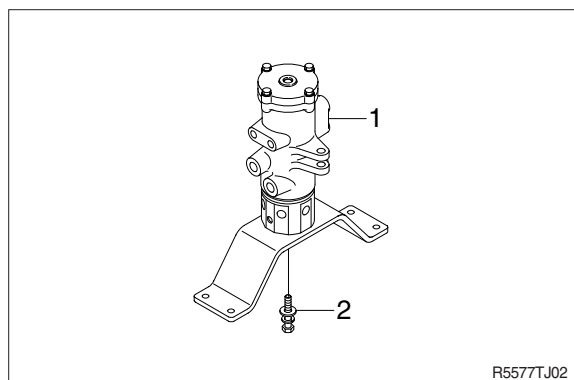
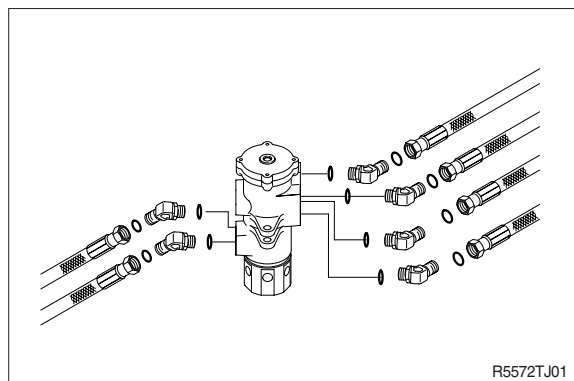

## 2. DISASSEMBLY AND ASSEMBLY

### 1) STRUCTURE

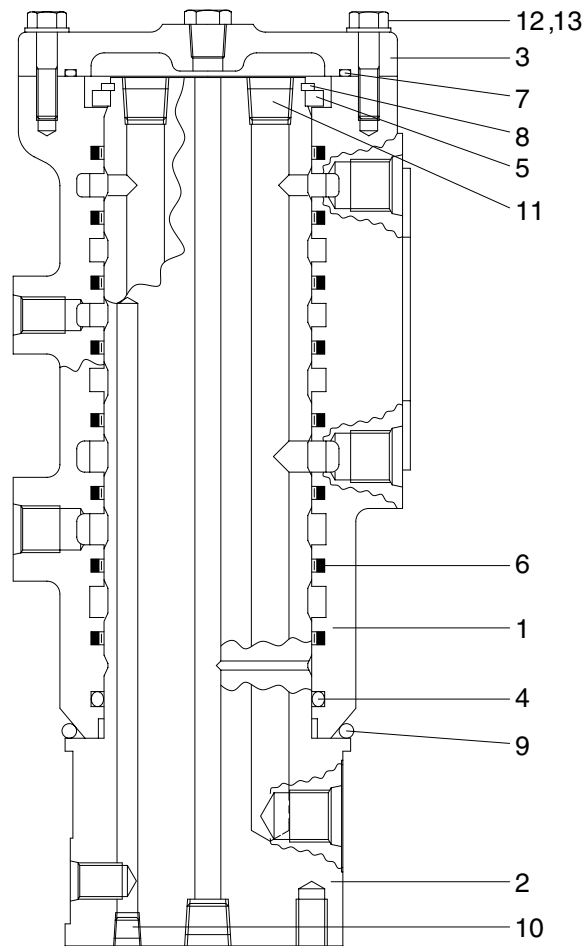

555K7TJ03

- |   |        |   |               |    |               |
|---|--------|---|---------------|----|---------------|
| 1 | Hub    | 6 | Slipper seal  | 10 | Plug          |
| 2 | Shaft  | 7 | O-ring        | 11 | Plug          |
| 3 | Cover  | 8 | Retainer ring | 12 | Hexagon bolt  |
| 4 | O-ring | 9 | O-ring        | 13 | Spring washer |
| 5 | Ring   |   |               |    |               |



## 2) DISASSEMBLY

※ Before the disassembly, clean the turning joint.

- (1) Remove bolts (12), washer (13) and cover (3).

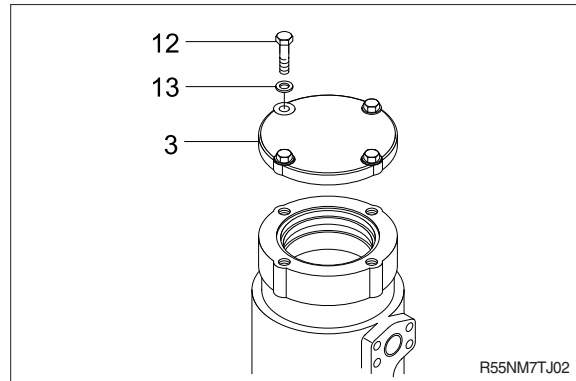

- (2) Remove O-ring (7).

- (3) Remove retainer ring (8) and ring (5).

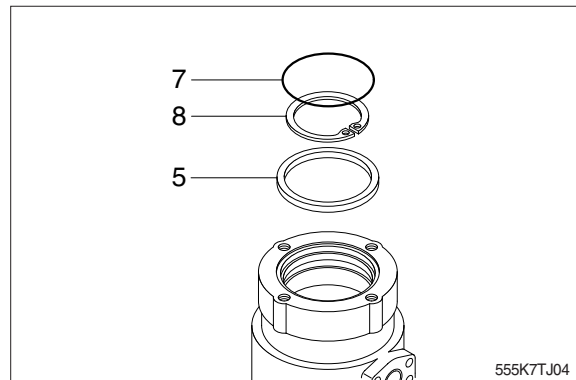

- (4) Place hub (1) on a V-block and by using a wood buffer at the shaft end, hit out shaft (2) to about 1/2 from the body with a hammer.

※ Take care not to damage the shaft (2) when remove hub (1) or rest it sideways.

※ Put a fitting mark on hub (1) and shaft (2).

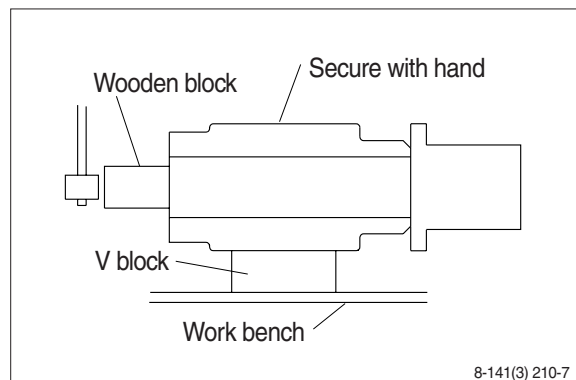

- (5) Remove eight slipper seals (6) and O-ring (4) from hub (1).

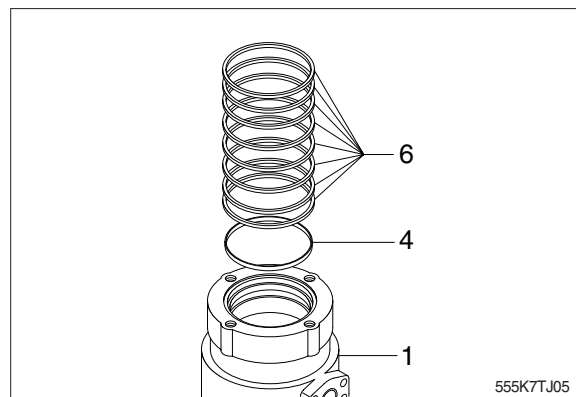

### 3) ASSEMBLY

- ※ Clean all parts.
- ※ As a general rule, replace oil seals and O-ring.
- ※ Coat the sliding surfaces of all parts with engine oil or grease before installing.

(1) Fix eight slipper seal (6) and O-ring (4) to hub (1).

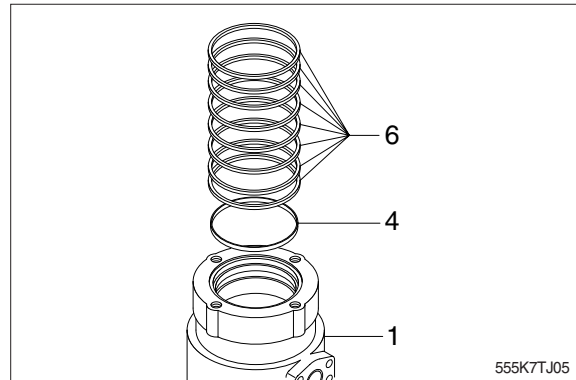

(2) Set shaft (2) on block, tap hub (1) with a plastic hammer to install.

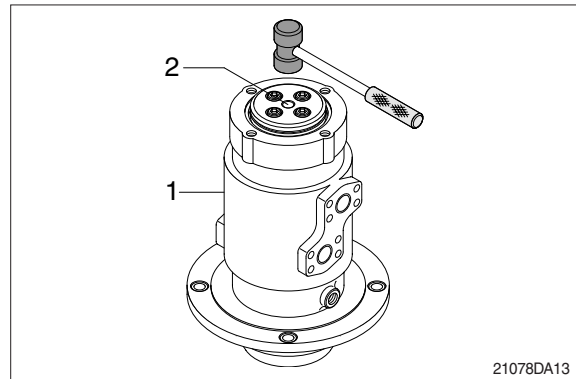

(3) Ring (5) and retainer ring (8) to shaft (2).

(4) Fit O-ring (7) to hub (1).

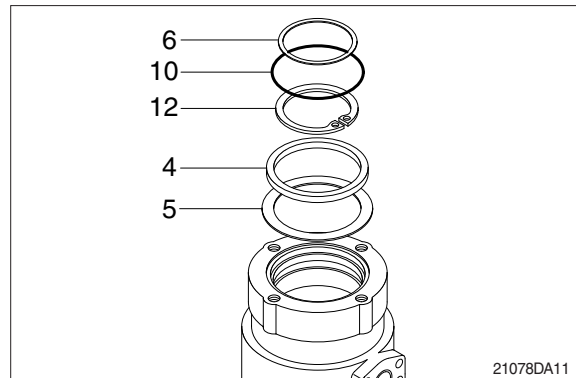

(5) Install cover (3) to body (1) and tighten bolts (12) with washer (13).

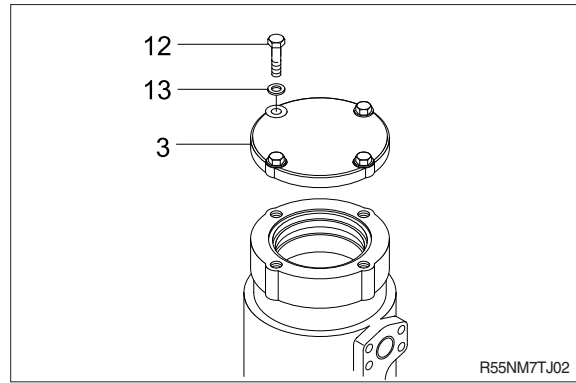

## GROUP 9 BOOM, ARM AND BUCKET CYLINDERS

### 1. REMOVAL AND INSTALL

#### 1) BUCKET CYLINDER

##### (1) Removal

- ※ Expand the arm and bucket fully, lower the work equipment to the ground and stop the engine.
- ※ Operate the control levers and pedals several times to release the remaining pressure in the hydraulic piping.

**▲ Loosen the breather slowly to release the pressure inside the hydraulic tank. Escaping fluid under pressure can penetrate the skin causing serious injury.**

- ※ Fit blind plugs in the hoses after disconnecting them, to prevent dirt or dust from entering.

① Set block between bucket cylinder and arm.

② Remove bolt (2), nut (3) and pull out pin (1).

- ※ Tie the rod with wire to prevent it from coming out.

③ Disconnect bucket cylinder hoses (4) and put plugs (5) on cylinder pipe.

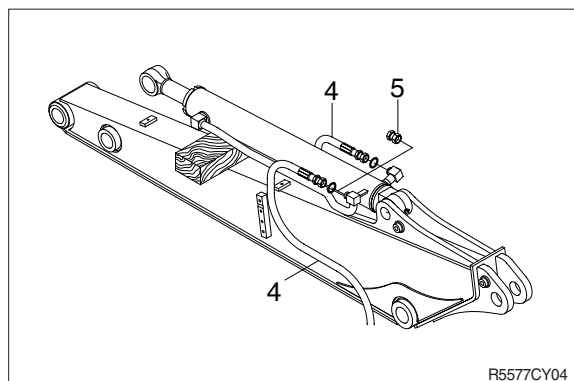
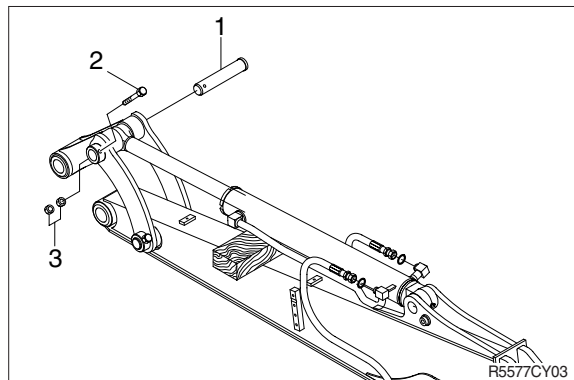
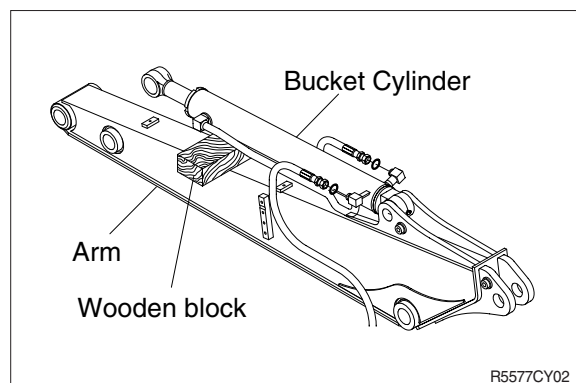

- ④ Sling bucket cylinder assembly (8) and remove bolt (6) then pull out pin (5).
- ⑤ Remove bucket cylinder assembly (8).
  - Weight : 60 kg (130 lb)

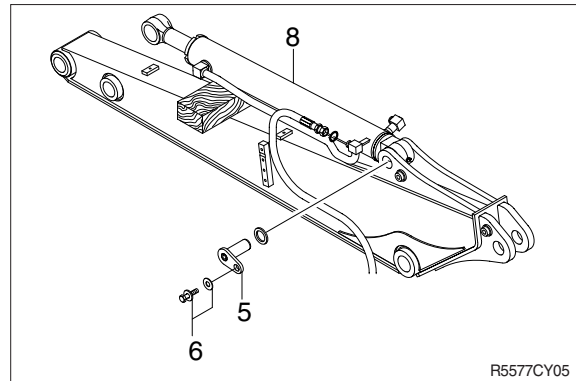

## (2) Install

- ① Carry out installation in the reverse order to removal.
- ▲ When aligning the mounting position of the pin, do not insert your fingers in the pin hole.**
- ※ Bleed the air from the bucket cylinder.
  - ※ Confirm the hydraulic oil level and check the hydraulic oil leak or not.



## 2) ARM CYLINDER

### (1) Removal

- ※ Expand the arm and bucket fully, lower the work equipment to the ground and stop the engine.
- ※ Operate the control levers and pedals several times to release the remaining pressure in the hydraulic piping.

**▲ Loosen the breather slowly to release the pressure inside the hydraulic tank.**

**▲ Escaping fluid under pressure can penetrate the skin causing serious injury.**

- ※ Fit blind plugs in the hoses after disconnecting them, to prevent dirt or dust from entering.

① Set block between arm cylinder and boom.

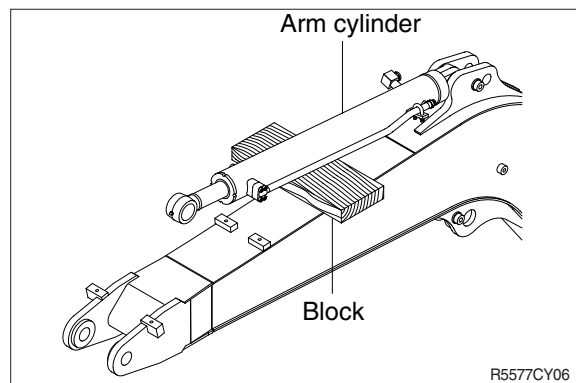

② Remove bolt (2) and pull out pin (1).

- ※ Tie the rod with wire to prevent it from coming out.

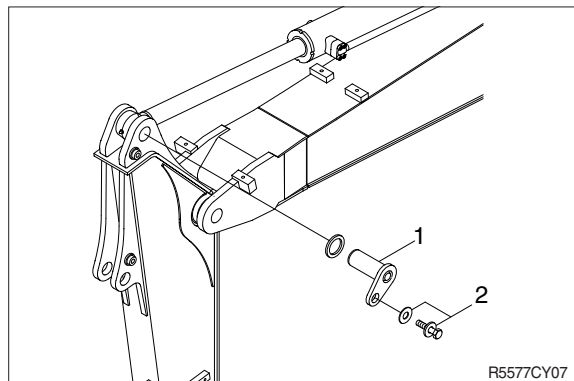

③ Disconnect arm cylinder hoses (4) and put plugs on cylinder pipe.

④ Disconnect greasing pipings (5).

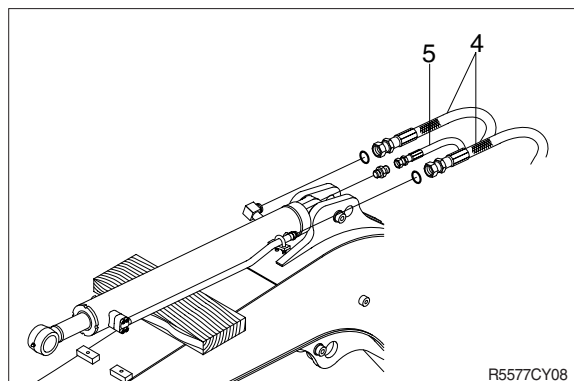

- ⑤ Sling arm assembly (8) and remove bolt (7) then pull out pin (6).
- ⑥ Remove arm cylinder assembly (8).
  - Weight : 90 kg (200 lb)

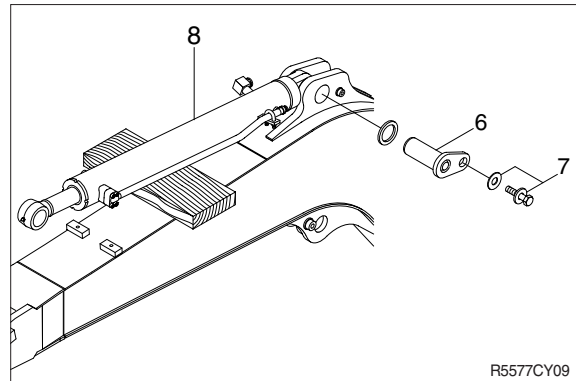

## (2) Install

- ① Carry out installation in the reverse order to removal.
- ▲ When aligning the mounting position of the pin, do not insert your fingers in the pin hole.**
- ※ Bleed the air from the arm cylinder.
  - ※ Confirm the hydraulic oil level and check the hydraulic oil leak or not.

### 3) BOOM CYLINDER

#### (1) Removal

- ※ Expand the arm and bucket fully, lower the work equipment to the ground and stop the engine.
- ※ Operate the control levers and pedals several times to release the remaining pressure in the hydraulic piping.

**▲ Loosen the breather slowly to release the pressure inside the hydraulic tank.**

**▲ Escaping fluid under pressure can penetrate the skin causing serious injury.**

- ※ Fit blind plugs in the hoses after disconnecting them, to prevent dirt or dust from entering.

- ① Disconnect greasing hoses.
- ② Sling boom cylinder assembly.

- ③ Remove bolt (2) and pull out pin (1).
- ※ Tie the rod with wire to prevent it from coming out.

- ④ Lower the boom cylinder assembly (3) on a stand.

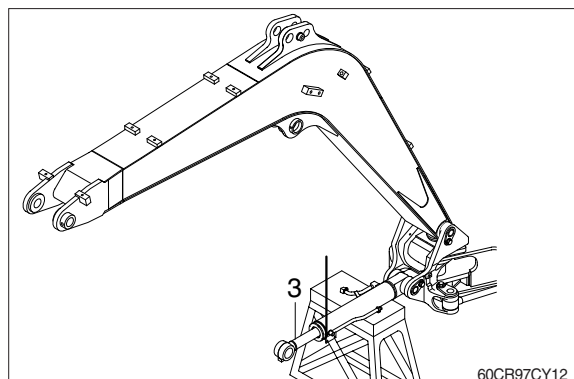
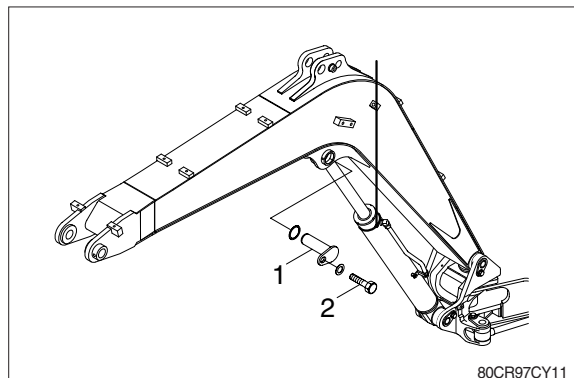
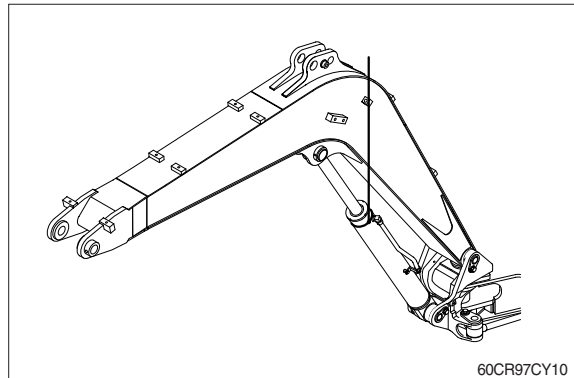

- ⑤ Disconnect boom cylinder hoses (4) and put plugs on cylinder pipe.

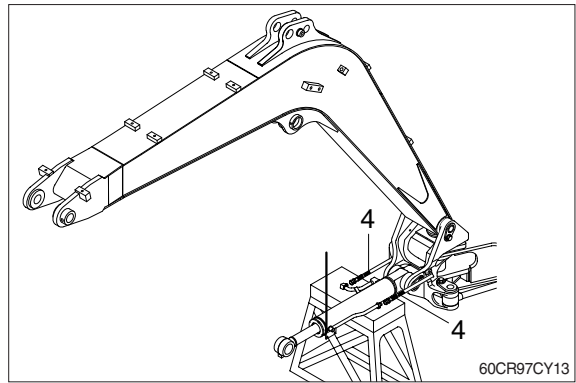

- ⑥ Remove bolt (6) and pull out pin (5).  
⑦ Remove boom cylinder assembly (3).  
· Weight : 110 kg (240 lb)

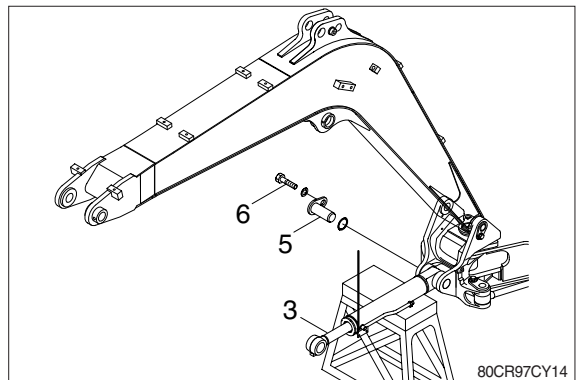

## (2) Install

- ① Carry out installation in the reverse order to removal.

**▲ When aligning the mounting position of the pin, do not insert your fingers in the pin hole.**

- ※ Bleed the air from the boom cylinder.
- ※ Confirmed the hydraulic oil level and check the hydraulic oil leak or not.

## 2. DISASSEMBLY AND ASSEMBLY

### 1) STRUCTURE

#### (1) Bucket cylinder

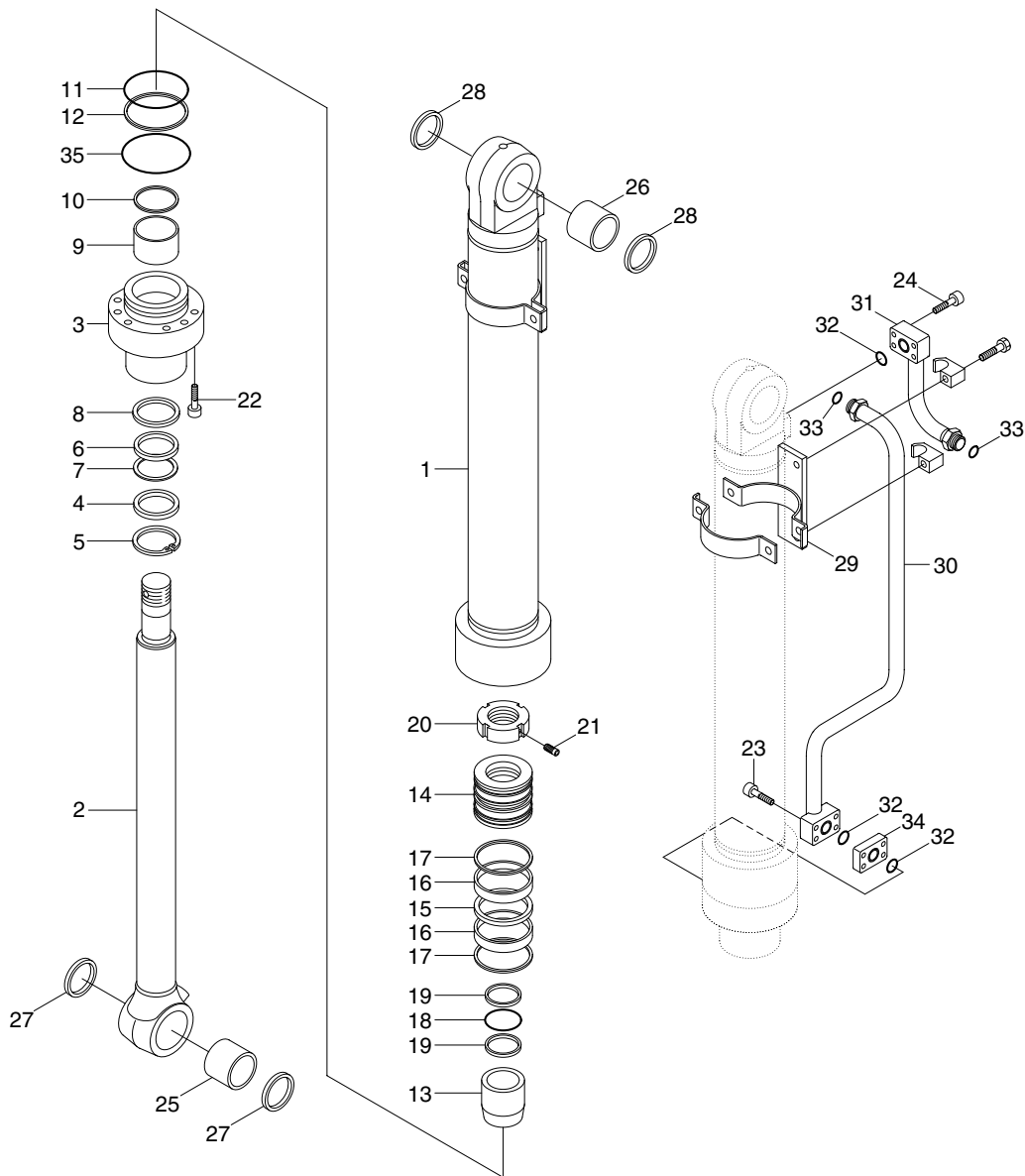

1	Tube assy	13	Cushing ring	25	Pin bushing
2	Rod assy	14	Piston	26	Pin bushing
3	Gland	15	Piston seal	27	Dust seal
4	Dust wiper	16	Wear ring	28	Dust seal
5	Retaining ring	17	Dust ring	29	Band assy
6	Rod seal	18	O-ring	30	Pipe assy
7	Back up ring	19	Back up ring	31	Pipe assy-B
8	Buffer ring	20	Lock nut	32	O-ring
9	Bushing	21	Set screw	33	O-ring
10	Retaining ring	22	Socket bolt	34	Flange
11	O-ring	23	Socket bolt	35	O-ring
12	Back up ring	24	Socket bolt		

80CR97CY20



## (2) Arm cylinder

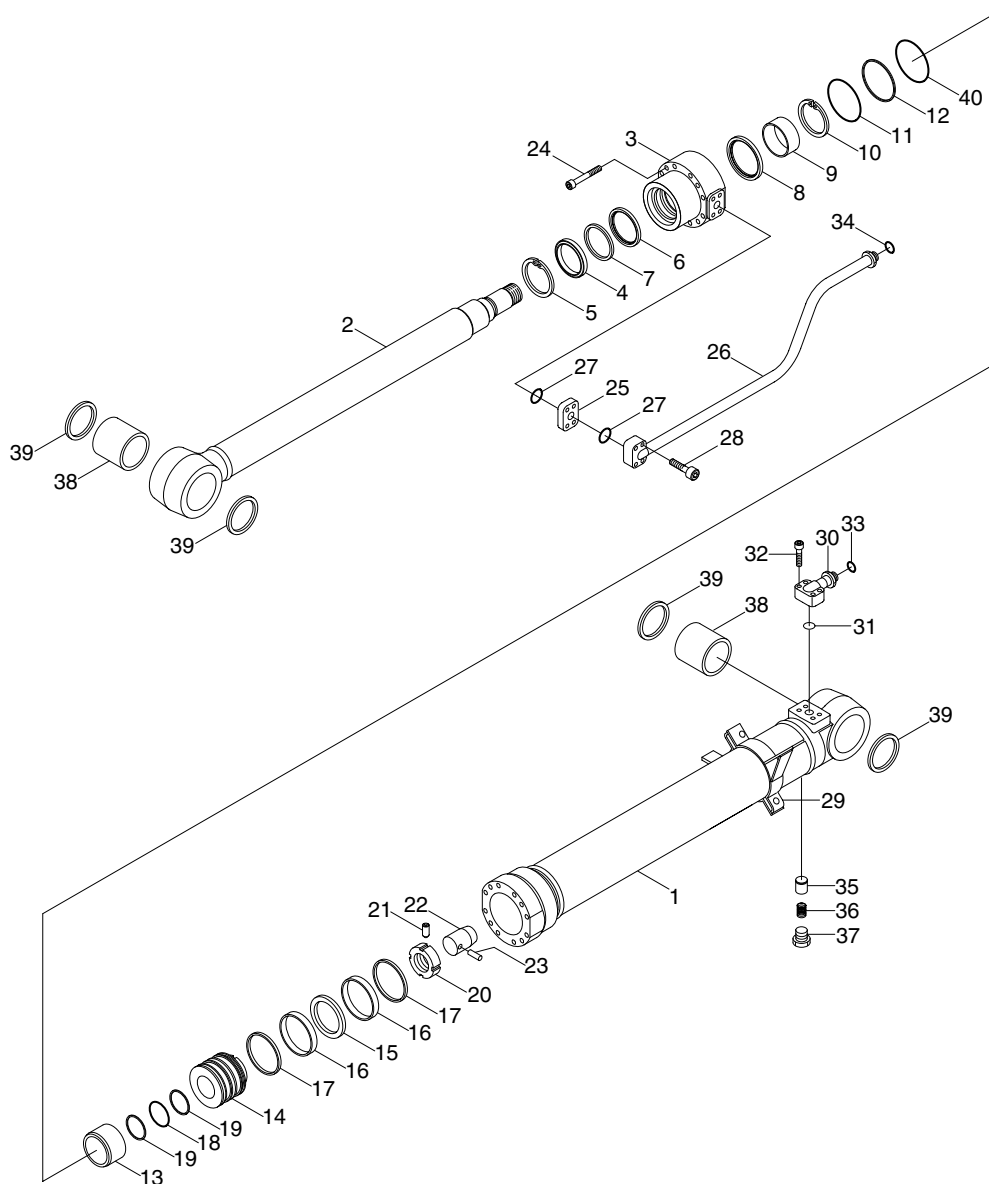

- |    |                |    |              |    |             |
|----|----------------|----|--------------|----|-------------|
| 1  | Tube assy      | 15 | Piston seal  | 29 | Band assy   |
| 2  | Rod assy       | 16 | Wear ring    | 30 | Pipe assy-B |
| 3  | Gland          | 17 | Dust ring    | 31 | O-ring      |
| 4  | Dust wiper     | 18 | O-ring       | 32 | Socket bolt |
| 5  | Retaining ring | 19 | Back up ring | 33 | O-ring      |
| 6  | Rod seal       | 20 | Lock nut     | 34 | O-ring      |
| 7  | Back up ring   | 21 | Set screw    | 35 | Check valve |
| 8  | Buffer ring    | 22 | Plunger      | 36 | Coil spring |
| 9  | Dry bearing    | 23 | Parallel pin | 37 | Plug        |
| 10 | Retaining ring | 24 | Socket bolt  | 38 | Pin bushing |
| 11 | O-ring         | 25 | Flange       | 39 | O-ring      |
| 12 | Back up ring   | 26 | Pipe assy-R  | 40 | O-ring      |
| 13 | Cushing ring   | 27 | O-ring       |    |             |
| 14 | Piston         | 28 | Socket bolt  |    |             |

80CR97CY21

### (3) Boom cylinder

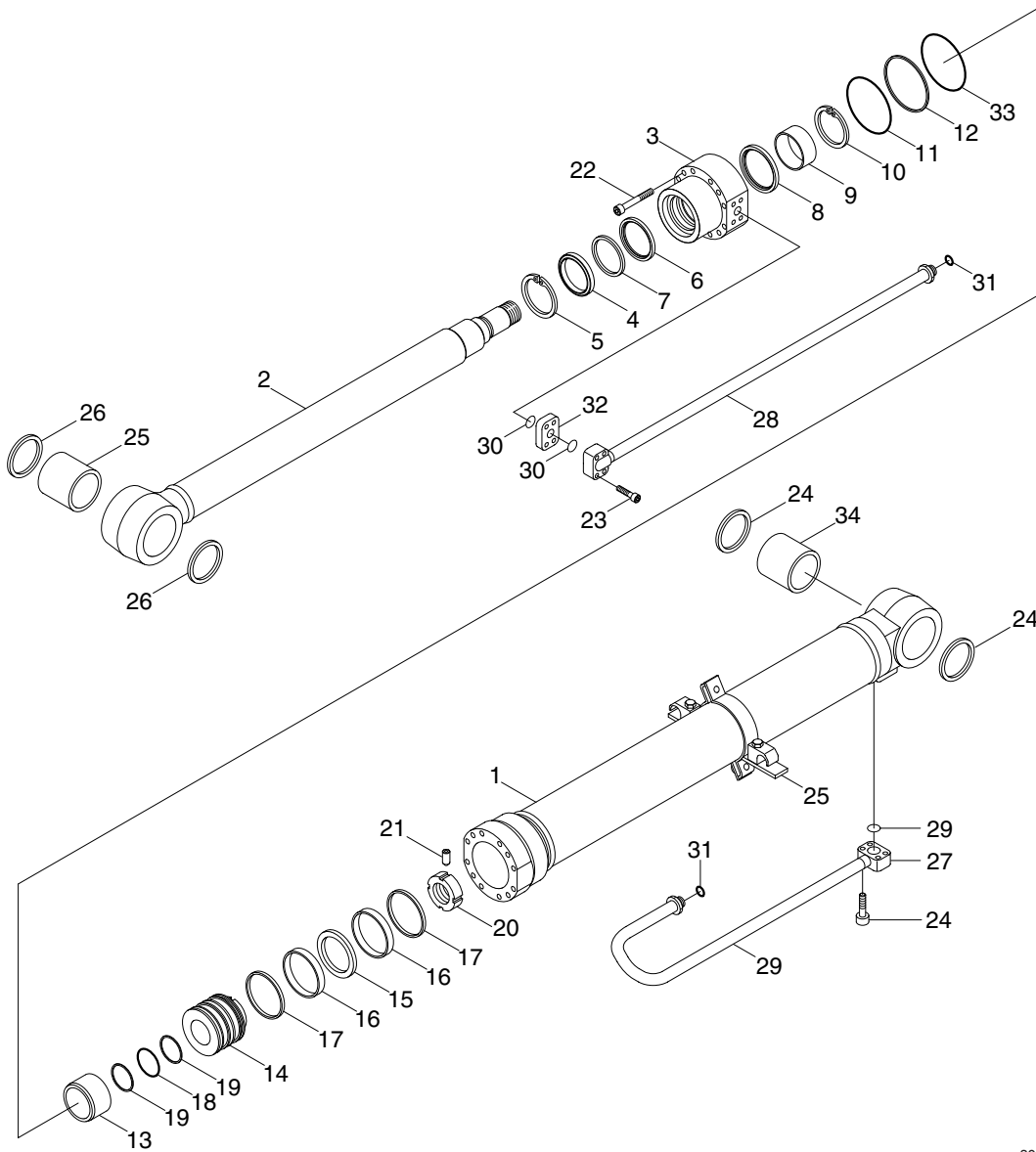

80CR97CY22

- |    |                |    |              |    |             |
|----|----------------|----|--------------|----|-------------|
| 1  | Tube assy      | 12 | Back up ring | 23 | Socket bolt |
| 2  | Rod assy       | 13 | Cushing ring | 24 | Socket bolt |
| 3  | Gland          | 14 | Piston       | 25 | Pin bush    |
| 4  | Dust wiper     | 15 | Piston seal  | 26 | Dust seal   |
| 5  | Retaining ring | 16 | Wear ring    | 27 | Band assy   |
| 6  | Rod seal       | 17 | Dust ring    | 28 | Pipe assy-R |
| 7  | Back up ring   | 18 | O-ring       | 29 | Pipe assy-B |
| 8  | Buffer ring    | 19 | Back up ring | 30 | O-ring      |
| 9  | Bushing        | 20 | Lock nut     | 31 | O-ring      |
| 10 | Retaining ring | 21 | Set screw    | 32 | Flange      |
| 11 | O-ring         | 22 | Socket bolt  | 33 | O-ring      |

#### (4) Dozer cylinder

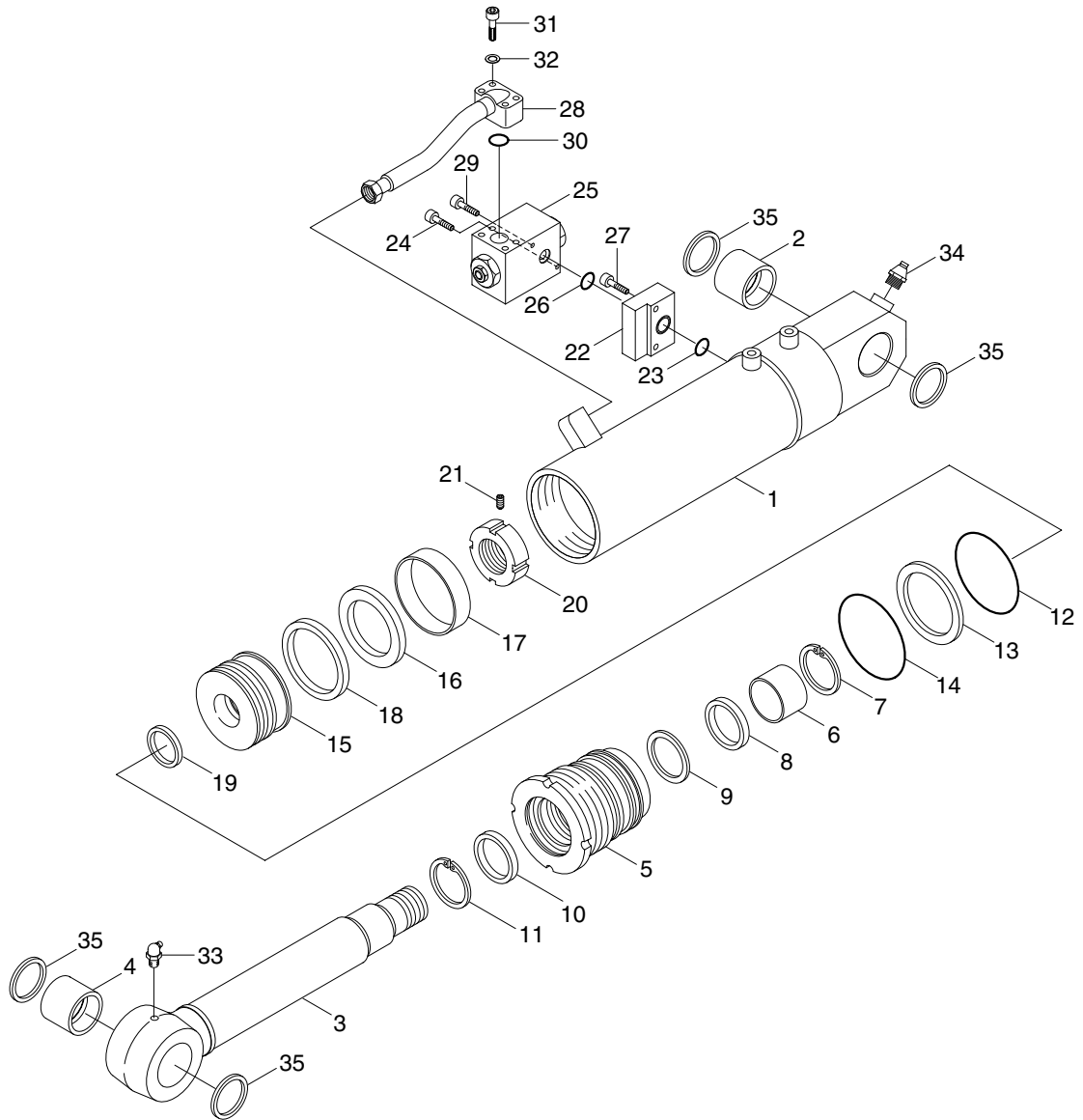

80CR97CY23

- |    |                |    |                 |    |                 |
|----|----------------|----|-----------------|----|-----------------|
| 1  | Tube assy      | 13 | Back up ring    | 25 | Check valve     |
| 2  | Pin bushing    | 14 | O-ring          | 26 | O-ring          |
| 3  | Gland          | 15 | Piston          | 27 | Hex socket bolt |
| 4  | Pin bushing    | 16 | Piston seal     | 28 | Pipe assy       |
| 5  | Rod cover      | 17 | Wear ring       | 29 | Hex socket bolt |
| 6  | Rod bush       | 18 | Dust ring       | 30 | O-ring          |
| 7  | Retaining ring | 19 | O-ring          | 31 | Hex socket bolt |
| 8  | Buffer seal    | 20 | Piston nut      | 32 | Spring washer   |
| 9  | U-packing      | 21 | Set screw       | 33 | Grease nipple   |
| 10 | Dust wiper     | 22 | Spacer          | 34 | Grease nipple   |
| 11 | Retaining ring | 23 | O-ring          | 35 | Pin wiper       |
| 12 | O-ring         | 24 | Hex socket bolt |    |                 |

(5) Boom swing cylinder

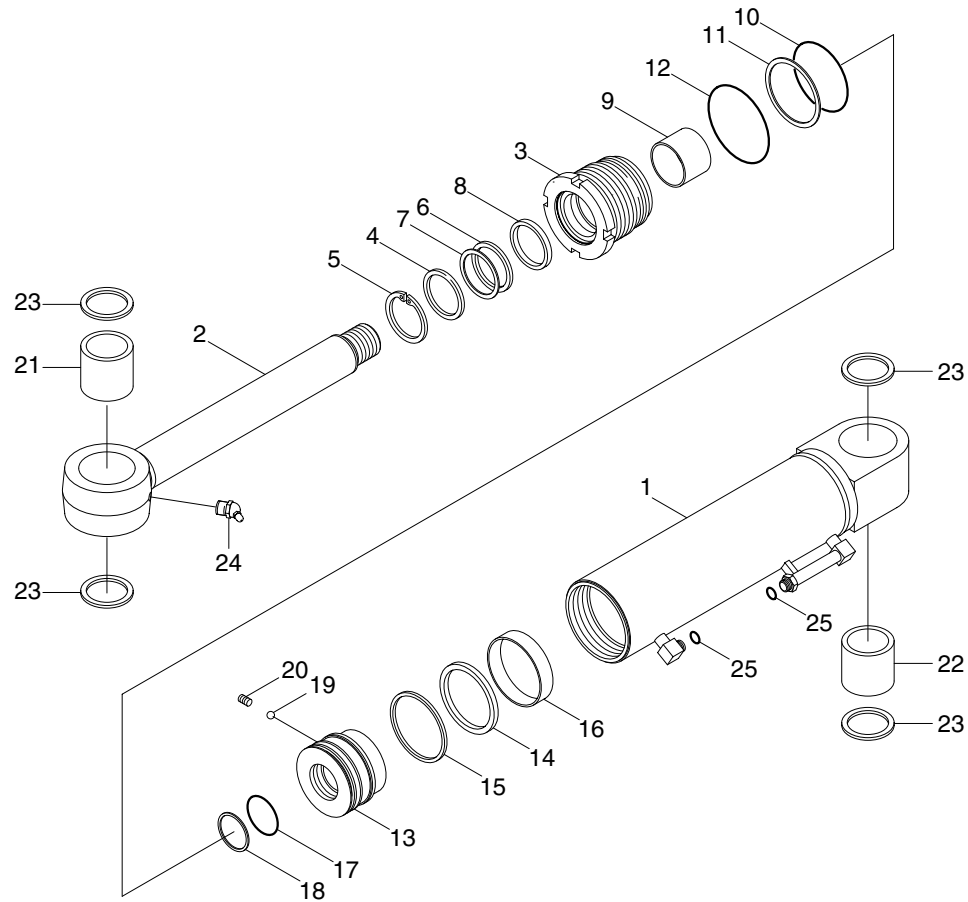

80CR97CY24

- |   |                |    |              |    |               |
|---|----------------|----|--------------|----|---------------|
| 1 | Tube assy      | 10 | O-ring       | 19 | Steel ball    |
| 2 | Rod assy       | 11 | Back up ring | 20 | Set screw     |
| 3 | Rod assy       | 12 | O-ring       | 21 | Pin bushing   |
| 4 | Dust wiper     | 13 | Piston       | 22 | Grease nipple |
| 5 | Retaining ring | 14 | Piston seal  | 23 | Dust seal     |
| 6 | Rod seal       | 15 | Dust ring    | 24 | Grease nipple |
| 7 | Back up ring   | 16 | Wear ring    | 25 | O-ring        |
| 8 | Buffer ring    | 17 | O-ring       |    |               |
| 9 | Du bushing     | 18 | Back up ring |    |               |

## 2) TOOLS AND TIGHTENING TORQUE

### (1) Tools

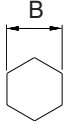
Name	Specification	
Allen wrench	8	
	10	
Spanner	M22	
Hook spanner	Suitable size	
(-) Driver	Small and large sizes	
Torque wrench	Capable of tightening with the specified torques	

### (2) Tightening torque

Part name		Item	Size	Torque	
				kgf · m	lbf · ft
Gland mounting bolt (socket head bolt)	Boom cylinder	22	M14 × 2.0	15 ± 1.5	108 ± 10.8
	Arm cylinder	24	M14 × 2.0	15 ± 1.5	108 ± 10.8
	Bucket cylinder	22	M12 × 1.75	9.4 ± 1.0	68 ± 7.2
Gland	Dozer cylinder	5	M135 × 2.0	75 ± 7.5	540 ± 54
	Boom swing cylinder	3	M115 × 2.0	92 ± 9.2	665 ± 66.5
Lock	Boom cylinder	20	M50 × 2.0	130 ± 13	940 ± 94
	Arm cylinder	20	M42 × 2.0	75 ± 7.5	540 ± 54
	Bucket cylinder	20	M39 × 2.0	75 ± 7.5	540 ± 54
	Dozer cylinder	20	M55 × 2.0	130 ± 13	940 ± 94
Piston	Boom cylinder	14	M60 × 3.0	75 ± 7.5	540 ± 54
	Arm cylinder	14	M55 × 2.0	60 ± 6.0	434 ± 43.4
	Bucket cylinder	14	M48 × 2.0	50 ± 5.0	362 ± 36.2
	Dozer cylinder	15	M65 × 3.0	75 ± 7.5	540 ± 54
	Boom swing	13	M50 × 2.0	125 ± 12.5	904 ± 90.4

### 3) DISASSEMBLY

#### (1) Remove cylinder head and piston rod

※ Procedures are based on the bucket cylinder.

① Hold the clevis section of the tube in a vise.

※ Use mouth pieces so as not to damage the machined surface of the cylinder tube. Do not make use of the outside piping as a locking means.

② Pull out rod assembly (2) about 200 mm (7.1 in). Because the rod assembly is rather heavy, finish extending it with air pressure after the oil draining operation.

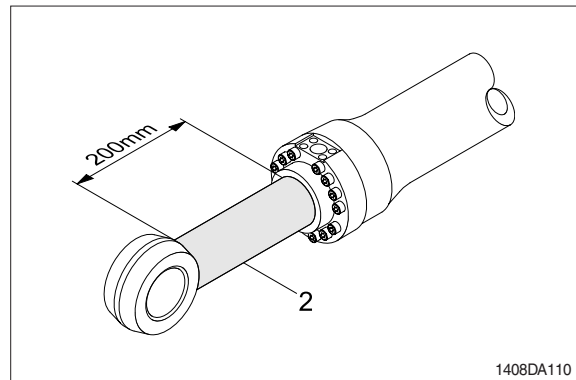

③ Loosen and remove socket bolts (22) of the gland in sequence.

※ Cover the extracted rod assembly (2) with rag to prevent it from being accidentally damaged during operation.

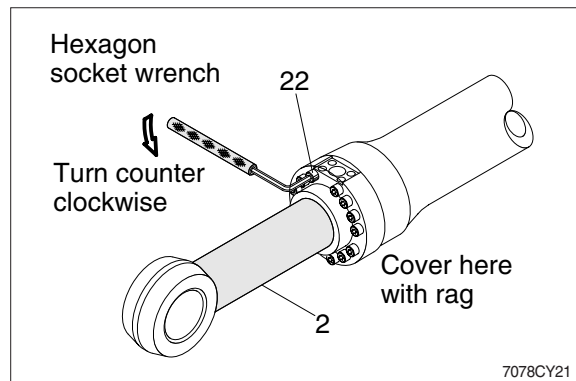

④ Draw out cylinder head and rod assembly together from tube assembly (1).

※ Since the rod assembly is heavy in this case, lift the tip of the rod assembly (2) with a crane or some means and draw it out. However, when rod assembly (2) has been drawn out to approximately two thirds of its length, lift it in its center to draw it completely.

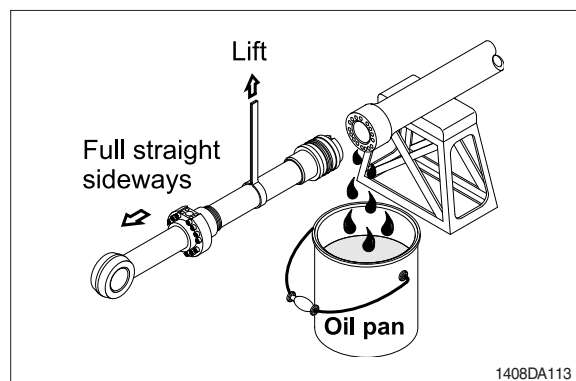



Note that the plated surface of rod assembly (2) is to be lifted. For this reason, do not use a wire sling and others that may damage it, but use a strong cloth belt or a rope.

- ⑤ Place the removed rod assembly on a wooden V-block that is set level.
- ※ Cover a V-block with soft rag.

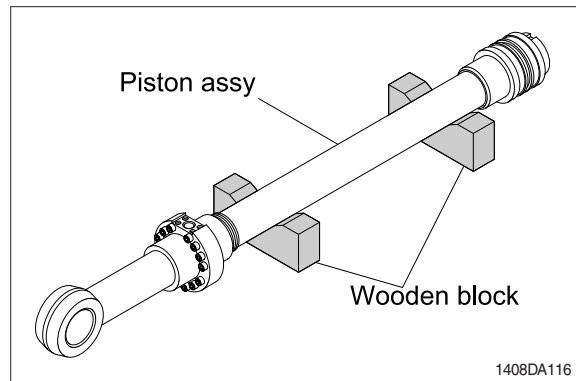

**(2) Remove piston and rod cover**

- ① Remove screw (21).  
Remove lock nut (20).
- ※ Since lock nut (20) is tightened to a high torque, use a hydraulic and power wrench that utilizes a hydraulic cylinder, to remove the lock nut (20).
- ② Remove piston assembly (14), back up ring (19), and O-ring (18).

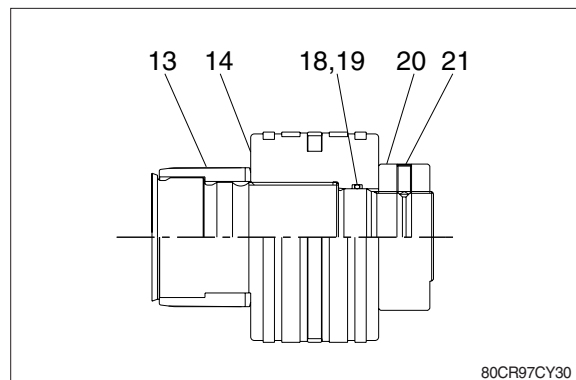

- ③ Remove the cylinder head assembly from rod assembly (2).
- ※ If it is too heavy to move, move it by striking the flanged part of cylinder head with a plastic hammer.
- ※ Pull it straight with cylinder head assembly lifted with a crane.  
Exercise care so as not to damage the lip of rod bushing (9) and packing (4, 5, 6, 7, 8) by the threads of rod assembly (2).

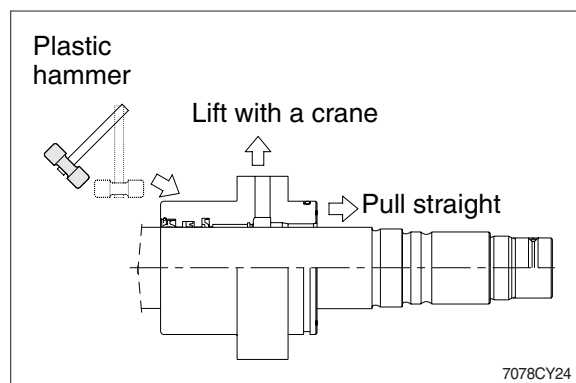

### (3) Disassemble the piston assembly

- ① Remove wear ring (16).
  - ② Remove dust ring (17) and piston seal (15).
- ※ Exercise care in this operation not to damage the grooves.

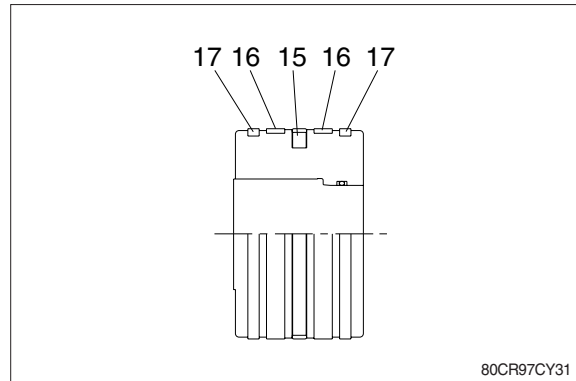

### (4) Disassemble gland assembly

- ① Remove back up ring (12) and O-ring (11).
  - ② Remove snap ring (5), dust wiper (4).
  - ③ Remove back up ring (7), rod seal (6) and buffer ring (8).
- ※ Exercise care in this operation not to damage the grooves.
- ※ Do not remove seal and ring, if does not damaged.

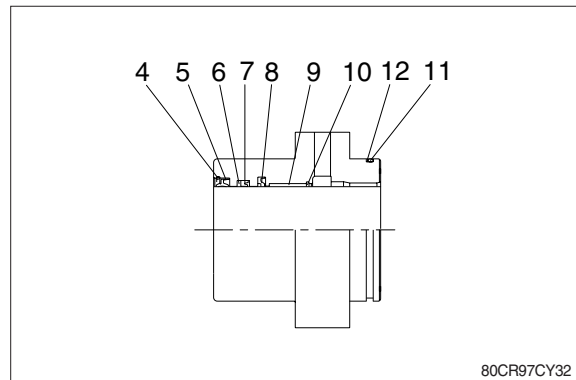

#### 4) ASSEMBLY

##### (1) Assemble cylinder head assembly

- ※ Check for scratches or rough surfaces if found smooth with an oil stone.
- ① Coat the inner face of gland (3) with hydraulic oil.

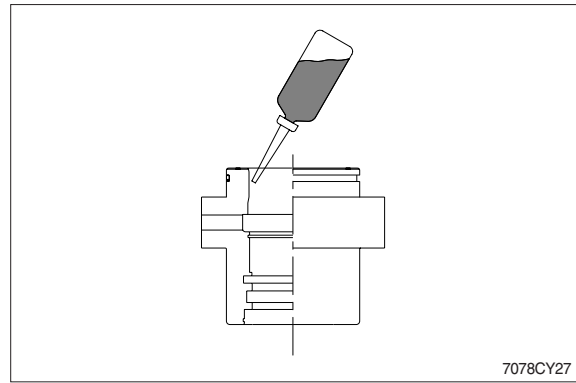

- ② Coat dust wiper (4) with grease and fit dust wiper (4) to the bottom of the hole of dust seal.  
At this time, press a pad metal to the metal ring of dust seal.
- ③ Fit snap ring (5) to the stop face.

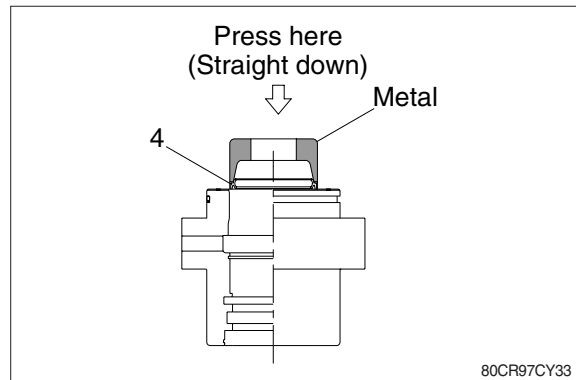

- ④ Fit back up ring (7), rod seal (6) and buffer ring (8) to corresponding grooves, in that order.  
※ Coat each packing with hydraulic oil before fitting it.  
※ Insert the backup ring until one side of it is inserted into groove.

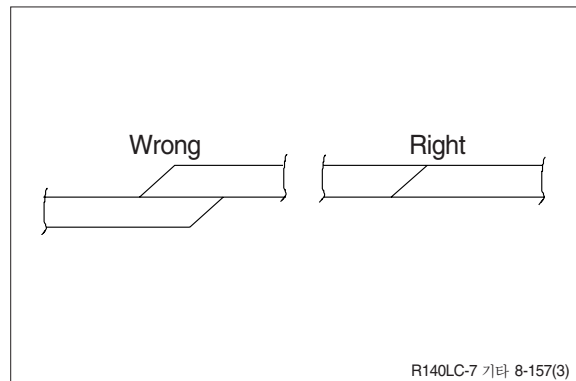

- ※ Rod seal (6) has its own fitting direction. Therefore, confirm it before fitting them.
- ※ Fitting rod seal (6) upside down may damage its lip. Therefore check the correct direction that is shown in fig.

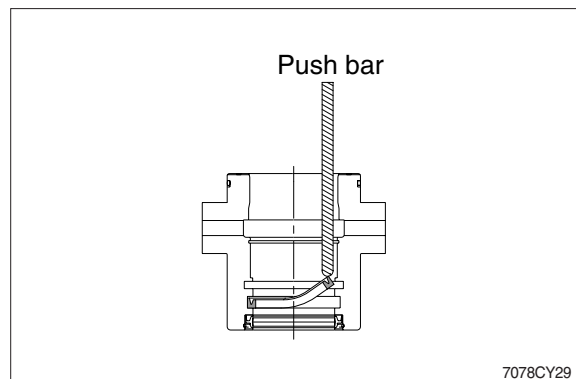

- ⑤ Fit back up ring (12) to gland (3).
- ※ Put the backup ring in the warm water of 30~50°C.
- ⑥ Fit O-ring (11) to gland (3).

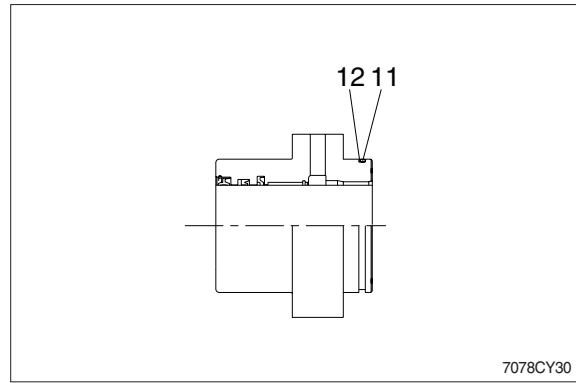

## (2) Assemble piston assembly

- ※ Check for scratches or rough surfaces. If found smooth with an oil stone.
- ① Coat the outer face of piston (14) with hydraulic oil.

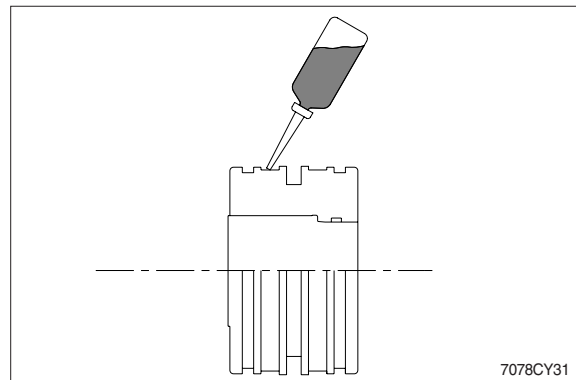

- ② Fit piston seal (15) to piston.
- ※ Put the piston seal in the warm water of 60~100°C for more than 5 minutes.
- ※ After assembling the piston seal, press its outer diameter to fit in.

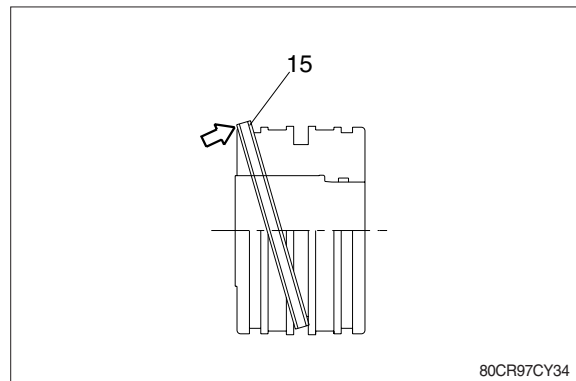

- ③ Fit wear ring (16) and dust ring (17) to piston (14).

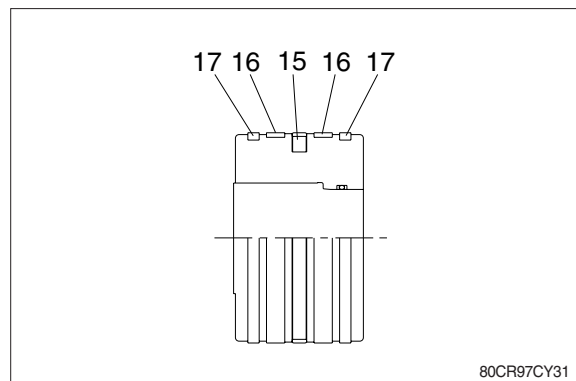

**(3) Install piston and cylinder head**

- ① Fix the rod assembly to the work bench.
- ② Apply hydraulic oil to the outer surface of rod assembly (2), the inner surface of piston and cylinder head.
- ③ Insert cylinder head assembly to rod assembly.

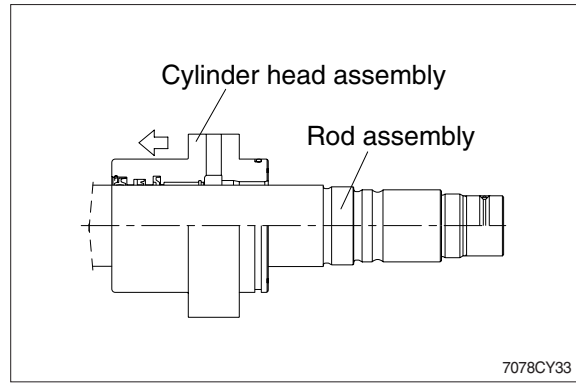

- ④ Insert cushion ring (13) to rod assembly. Note that cushion ring (13) has a direction in which it should be fitted.

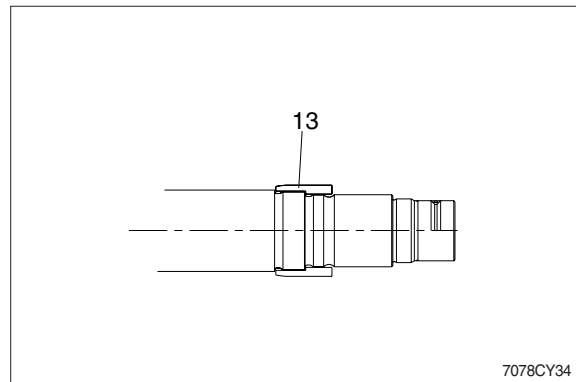

- ⑤ Fit piston assembly to rod assembly.
  - Tightening torque :

Item		kgf · m	lbf · ft
Boom	14	75 ± 7.5	540 ± 54
Arm	14	60 ± 6.0	434 ± 43
Bucket	14	50 ± 5.0	362 ± 36
Dozer	15	75 ± 7.5	540 ± 54
Boom swing	13	125 ± 12.5	904 ± 90

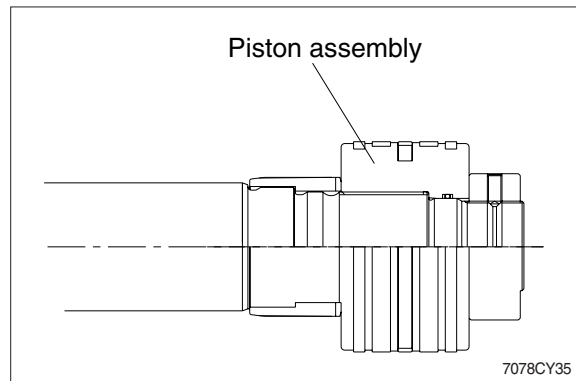

- ⑥ Fit lock nut (20) to piston and screw (21).
  - Tightening torque :

Item		kgf · m	lbf · ft
Boom	20	130 ± 13	940 ± 94
Arm	20	75 ± 7.5	542 ± 54
Bucket	20	75 ± 7.5	542 ± 54
Dozer	20	130 ± 13	940 ± 94

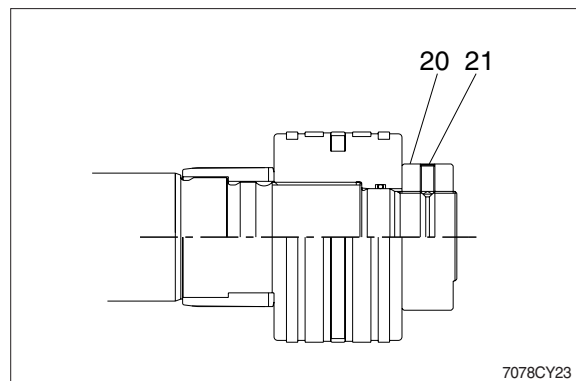

### (3) Overall assemble

- ① Place a V-block on a rigid work bench.  
Mount the tube assembly (1) on it and fix the assembly by passing a bar through the clevis pin hole to lock the assembly.
- ② Insert the rod assembly in to the tube assembly, while lifting and moving the rod assembly with a crane.
  - ※ Be careful not to damage piston seal by thread of tube assembly.
- ③ Match the bolt holes in the cylinder head flange to the tapped holes in the tube assembly and tighten socket bolts to a specified torque.
  - ※ Refer to the table of tightening torque.

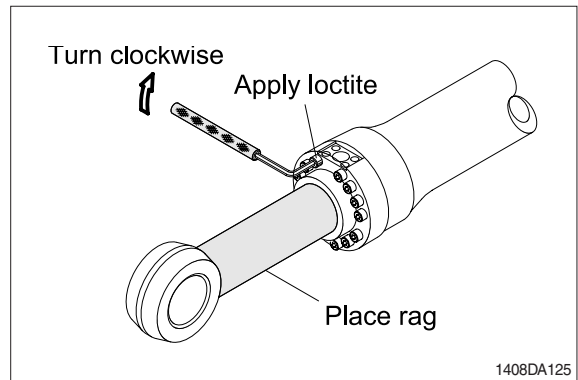
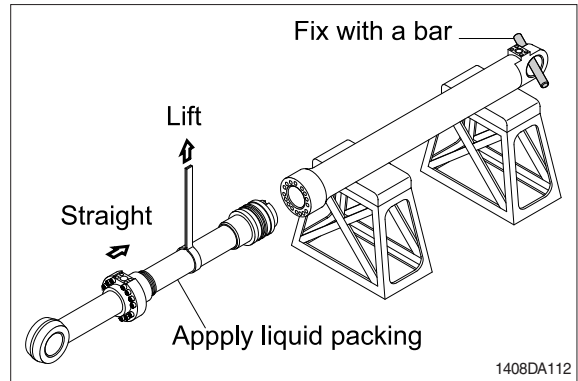



## GROUP 10 UNDERCARRIAGE

### 1. TRACK LINK

#### 1) REMOVAL

- (1) Move track link until master pin is over front idler in the position put wooden block as shown.
- (2) Loosen tension of the track link.
  - ※ If track tension is not relieved when the grease valve is loosened, move the machine backwards and forwards.
- (3) Push out master pin by using a suitable tool.

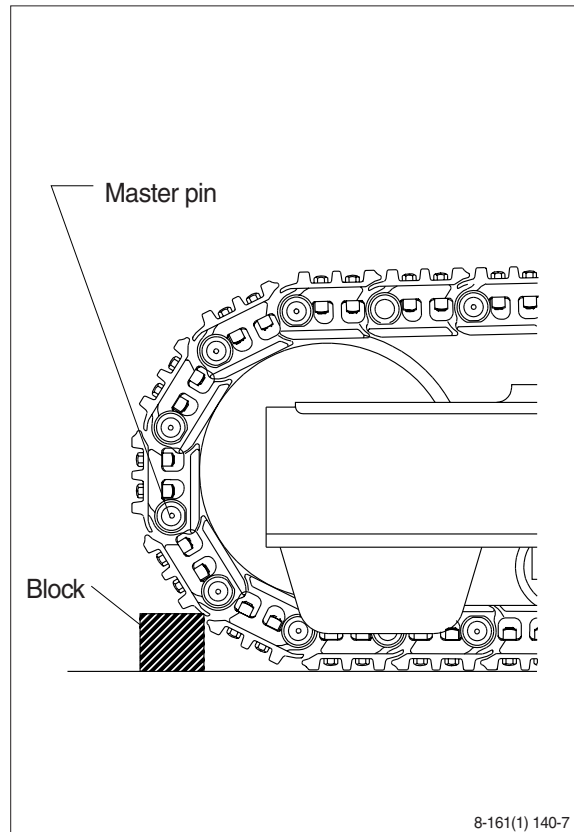

- (4) Move the machine slowly in reverse, and lay out track link assembly (1).
  - ※ Jack up the machine and put wooden block under the machine.
  - ※ Don't get close to the sprocket side as the track shoe plate may fall down on your feet.

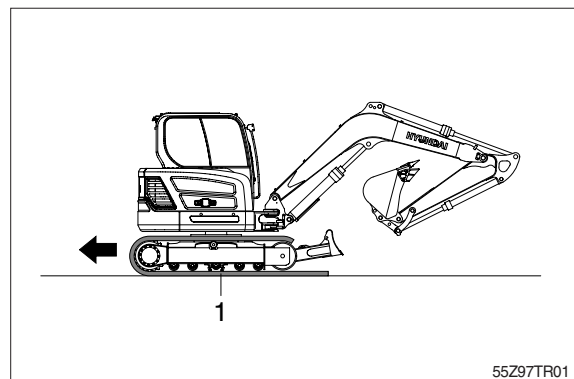

#### 2) INSTALL

- (1) Carry out installation in the reverse order to removal.
  - ※ Adjust the tension of the track link.

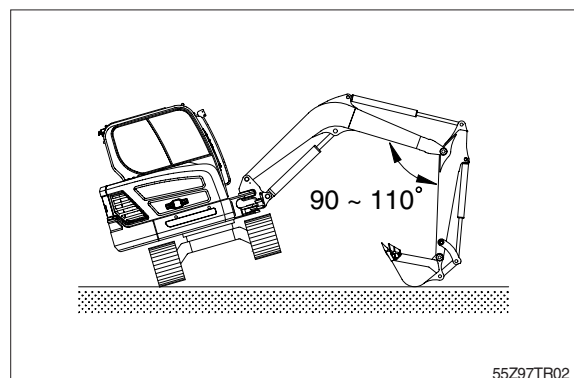

## 2. CARRIER ROLLER

### 1) REMOVAL

- (1) Loosen tension of the track link.

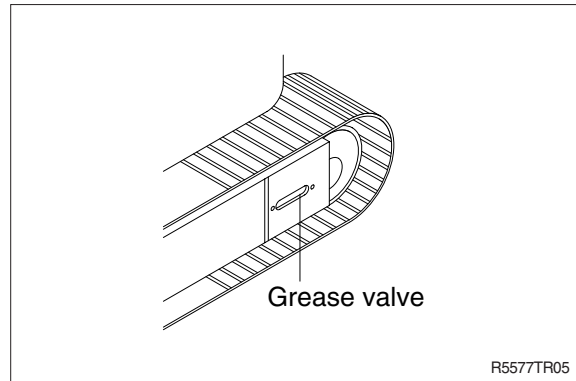

- (2) Jack up the track link height enough to permit carrier roller removal.

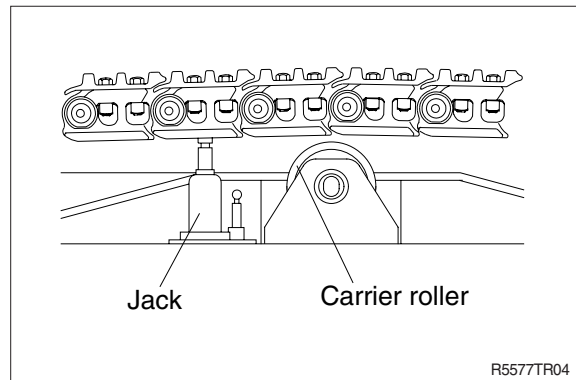

- (3) Remove bolt (1) at both side.
- (4) Remove carrier roller (2).
  - Weight : 10 kg (20 lb)

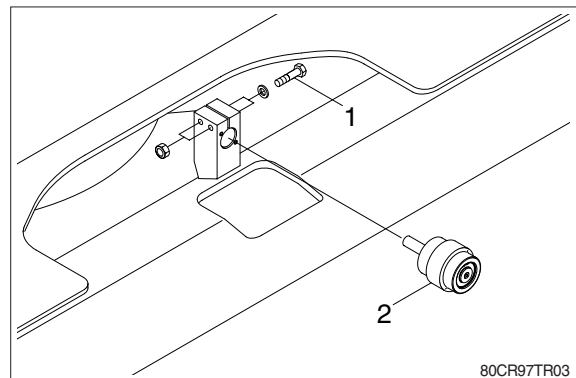

### 2) INSTALL

- (1) Carry out installation in the reverse order to removal.

### 3. TRACK ROLLER

#### 1) REMOVAL

- (1) Loosen tension of the track link.

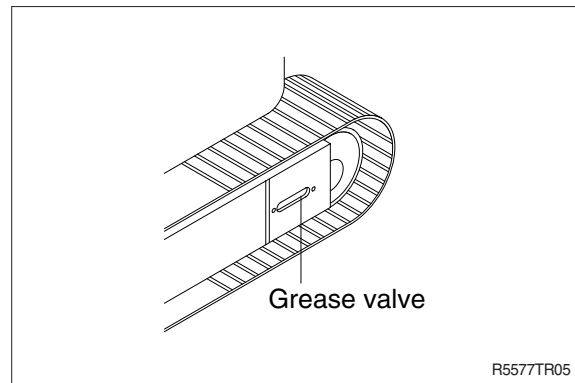

- (2) Using the work equipment, push up track frame on side which is to be removed.  
※ After jack up the machine, set a block under the unit.

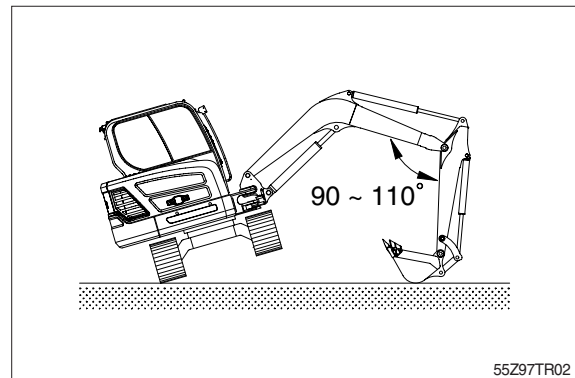

- (3) Remove the mounting bolt (1) and draw out the track roller (3).  
· Weight : 16 kg (36 lb)

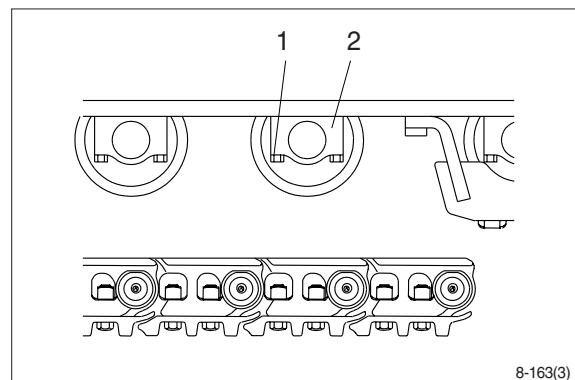

#### 2) INSTALL

- (1) Carry out installation in the reverse order to removal.

## 4. IDLER AND RECOIL SPRING

### 1) REMOVAL

- (1) Remove the track link.  
For detail, see removal of track link.

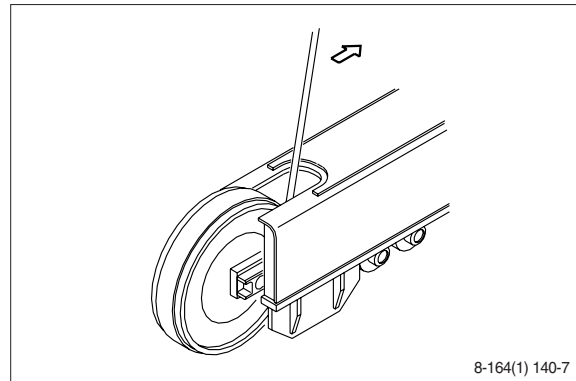

- (2) Sling the recoil spring (1) and pull out idler and recoil spring assembly from track frame, using a pry.  
· Weight : 110 kg (240 lb)

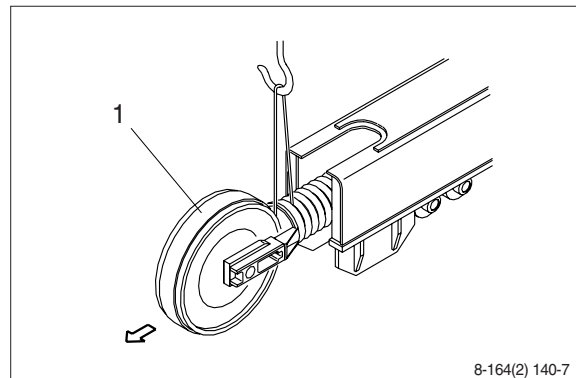

- (3) Remove the bolts (2), washers (3) and separate idler from recoil spring.

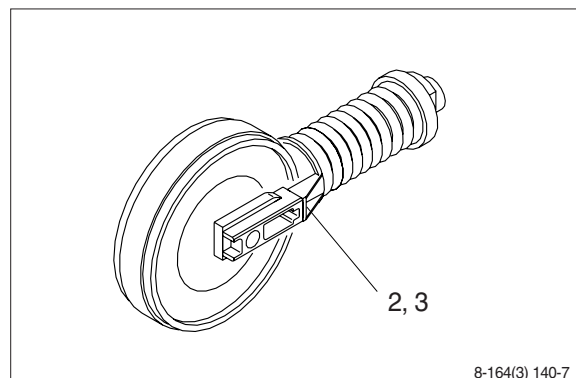

### 2) INSTALL

- (1) Carry out installation in the reverse order to removal.  
※ Make sure that the boss on the end face of the recoil cylinder rod is in the hole of the track frame.

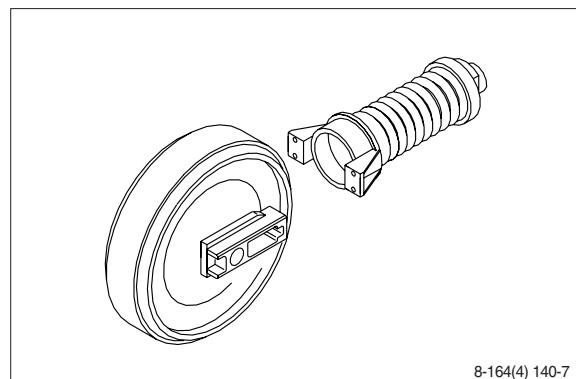

### 3) DISASSEMBLY AND ASSEMBLY OF IDLER

#### (1) Structure

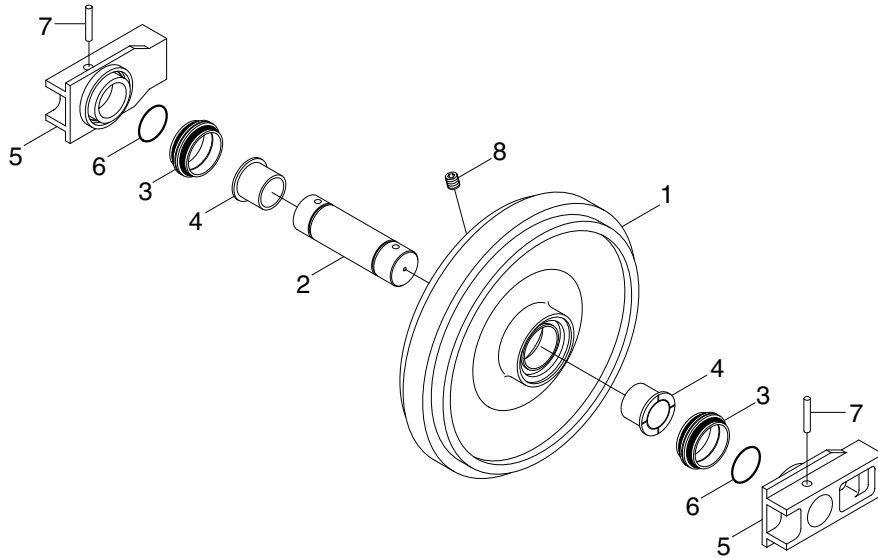

80CR97ID30

- |   |               |   |         |   |            |
|---|---------------|---|---------|---|------------|
| 1 | Shell         | 4 | Bushing | 7 | Spring pin |
| 2 | Shaft         | 5 | Bracket | 8 | Plug       |
| 3 | Seal assembly | 6 | O-ring  |   |            |

## (2) Disassembly

- ① Remove plug and drain oil.
- ② Draw out the spring pin (7), using a press.

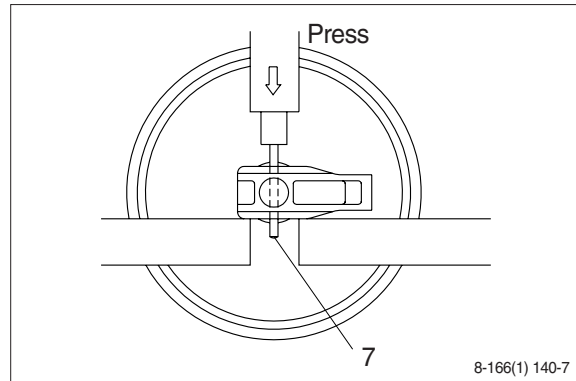

- ③ Pull out the shaft (2) with a press.
- ④ Remove seal (3) from idler (1) and bracket (5).
- ⑤ Remove O-ring (6) from shaft.

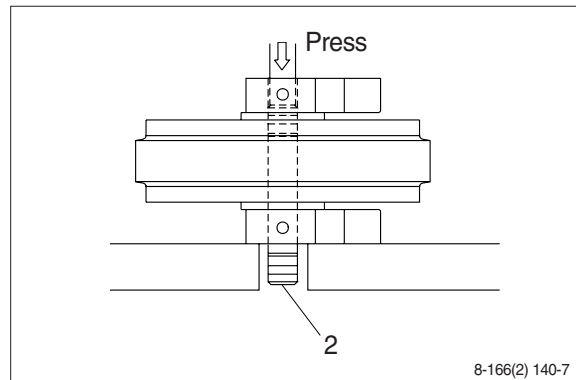

- ⑥ Remove the bushing (4) from idler, using a special tool.
- ※ Only remove bushing if replacement is necessary.

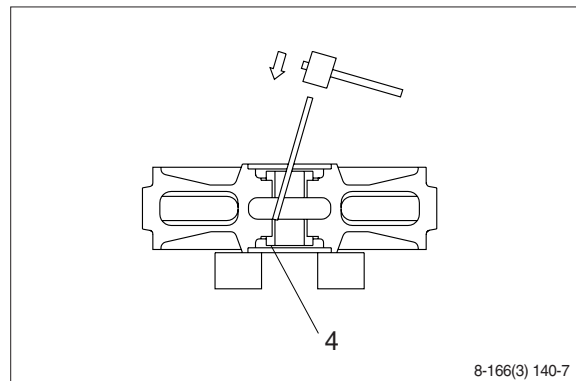



### (3) Assembly

- ※ Before assembly, clean the parts.
- ※ Coat the sliding surfaces of all parts with oil.

- ① Cool up bushing (4) fully by some dry ice and press it into shell (1).

Do not press it at the normal temperature, or not knock in with a hammer even after the cooling.

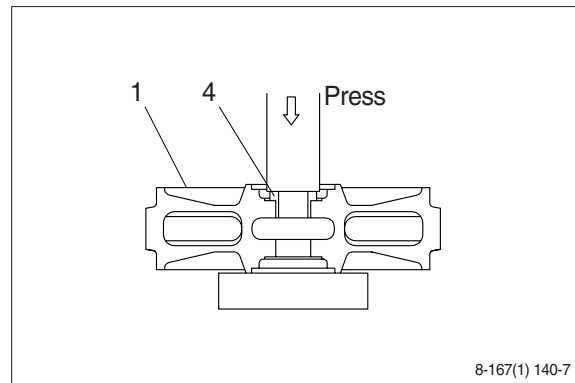

- ② Coat O-ring (6) with grease thinly, and install it to shaft (2).

- ③ Insert shaft (2) into bracket (5) and drive in the spring pin (7).

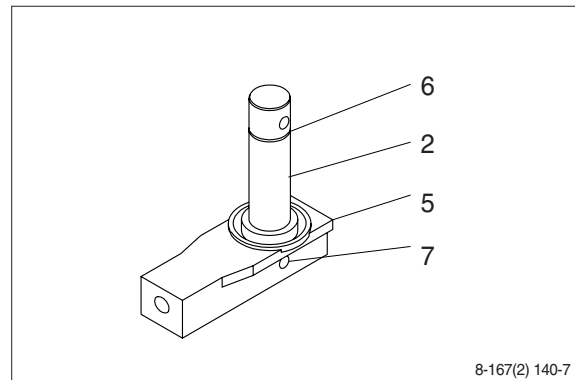

- ④ Install seal (3) to shell (1) and bracket (5).

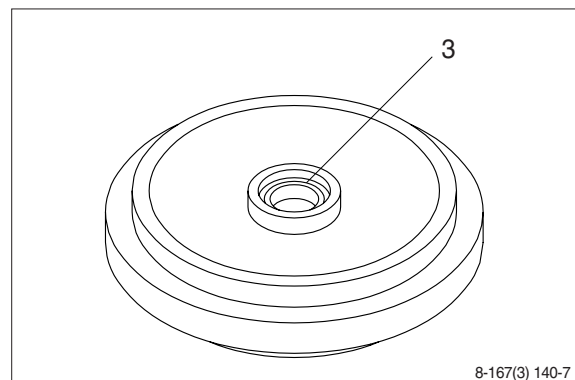

- ⑤ Install shaft (2) to shell (1).

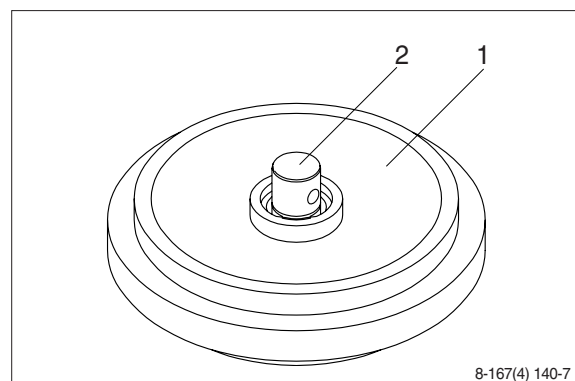

- ⑥ Install bracket (5) attached with seal (3).

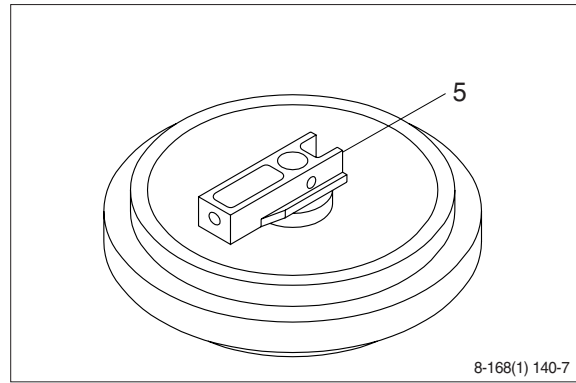

- ⑦ Knock in the spring pin (7) with a hammer.

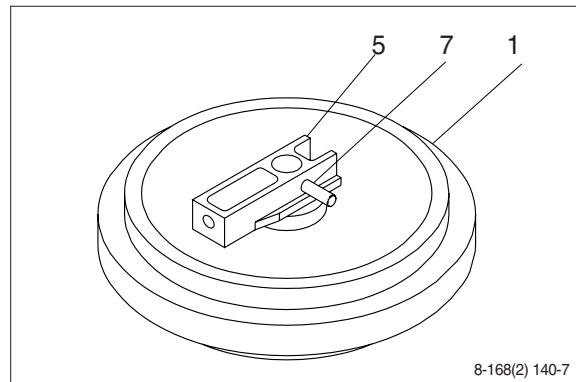

- ⑧ Lay bracket (5) on its side.  
Supply engine oil to the specified level,  
and tighten plug.

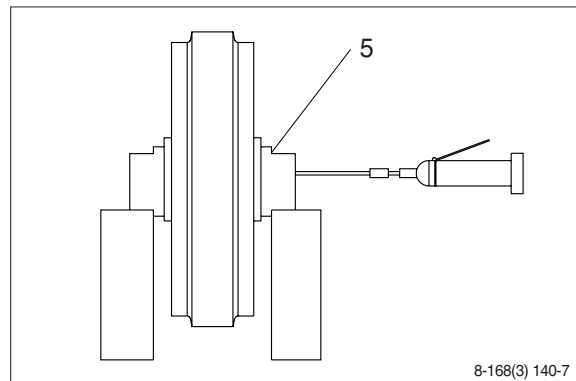

#### 4) DISASSEMBLY AND ASSEMBLY OF RECOIL SPRING

##### (1) Structure

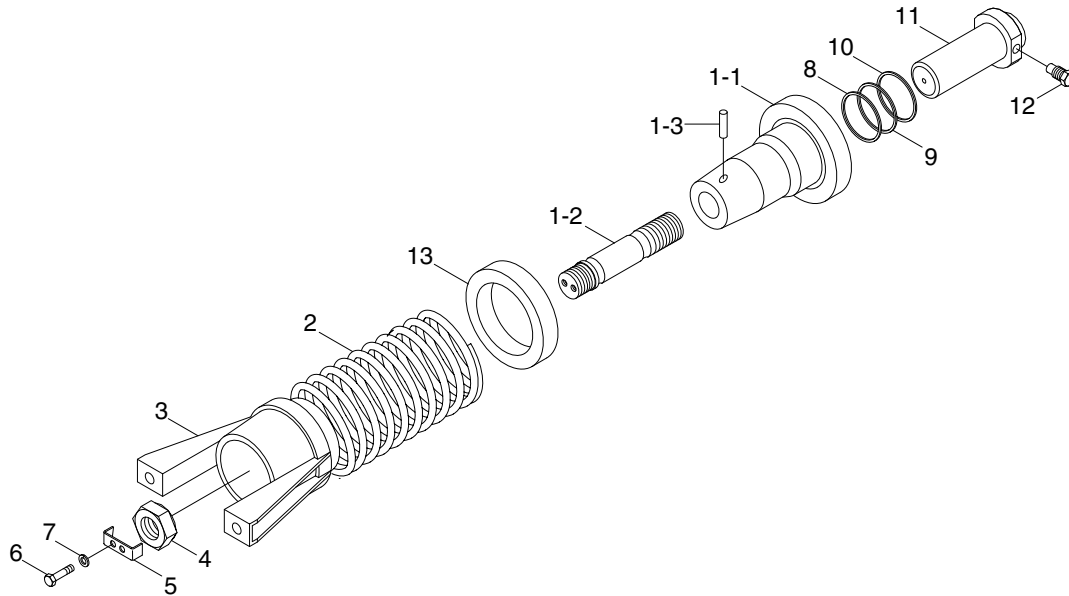

80CR97ID31

- |     |            |   |               |    |              |
|-----|------------|---|---------------|----|--------------|
| 1-1 | Body       | 4 | Lock nut      | 9  | Back up ring |
| 1-2 | Tie bar    | 5 | Lock plate    | 10 | Dust seal    |
| 1-3 | Spring pin | 6 | Bolt          | 11 | Rod assembly |
| 2   | Spring     | 7 | Spring washer | 12 | Grease valve |
| 3   | Bracket    | 8 | Rod seal      | 13 | Spacer       |

## (2) Disassembly

- ① Apply pressure on spring (2) with a press.
  - ※ The spring is under a large installed load. This is dangerous, so be sure to set properly.
    - Spring set load : 5083 kg (11210 lb)
- ② Remove bolt (6), spring washer (7) and lock plate (5).
- ③ Remove lock nut (4).

Take enough notice so that the press which pushes down the spring, should not be slipped out in its operation.
- ④ Lighten the press load slowly and remove bracket (3) and spring (2).

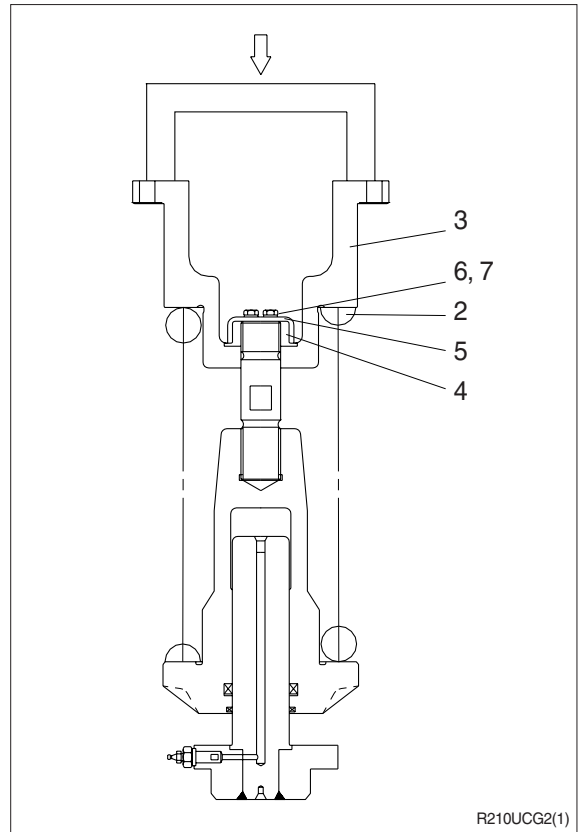

- ⑤ Remove rod (11) from body (1-1).
- ⑥ Remove grease valve (12) from rod (11).

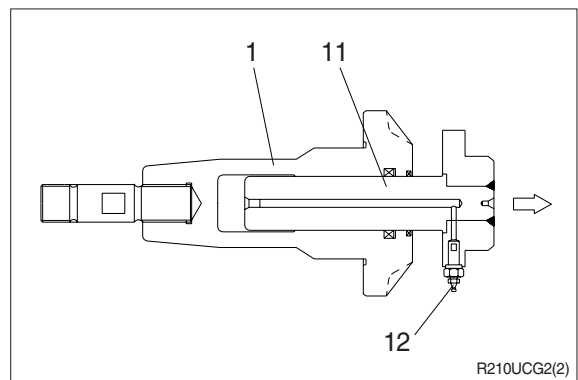

- ⑦ Remove rod seal (8), back up ring (9) and dust seal (10).

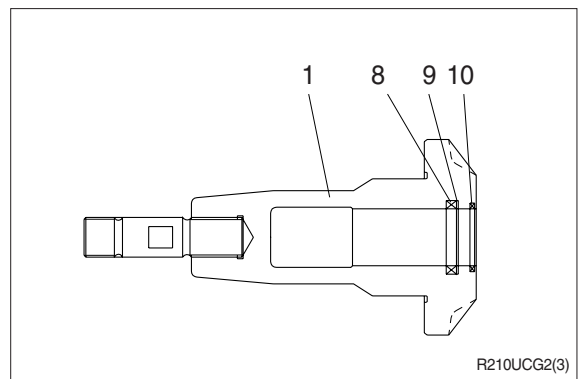

### (3) Assembly

Install dust seal (10), back up ring (9) and rod seal (8) to body (1-1).

- ※ When installing dust seal (10) and rod seal (8), take full care so as not to damage the lip.

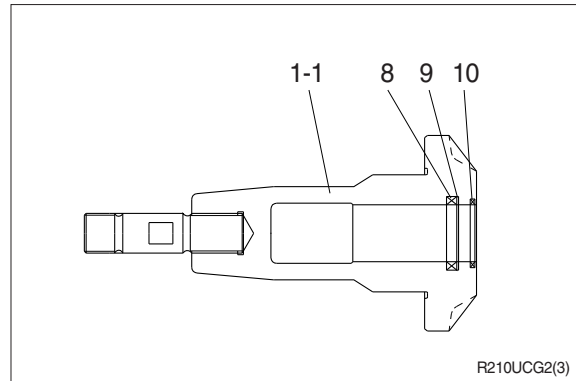

- ② Pour grease into body (1-1), then push in rod (11) by hand.

After take grease out of grease valve mounting hole, let air out.

- ※ If air letting is not sufficient, it may be difficult to adjust the tension of crawler.

- ③ Fit grease valve (12) to rod (11).

·Tightening torque :  $13 \pm 1.0$  kgf·m  
( $94 \pm 7.2$  lbf·ft)

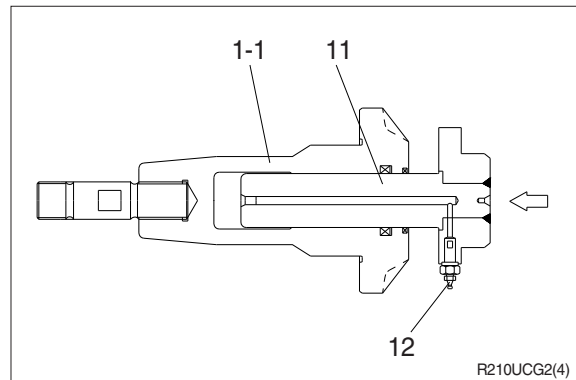

- ④ Install spring (2) and bracket (3) to body (1-1).

- ⑤ Apply pressure to spring (2) with a press and tighten lock nut (4).

- ※ Apply sealant before assembling.

- ※ During the operation, pay attention specially to prevent the press from slipping out.

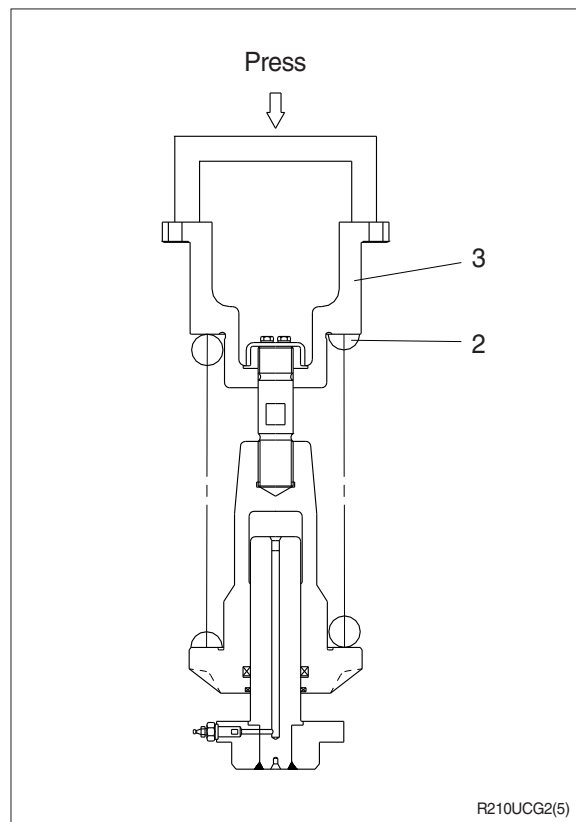

- ⑥ Lighten the press load and confirm the set length of spring (2).
- ⑦ After the setting of spring (2), install lock plate (5), spring washer (7) and bolt (6).

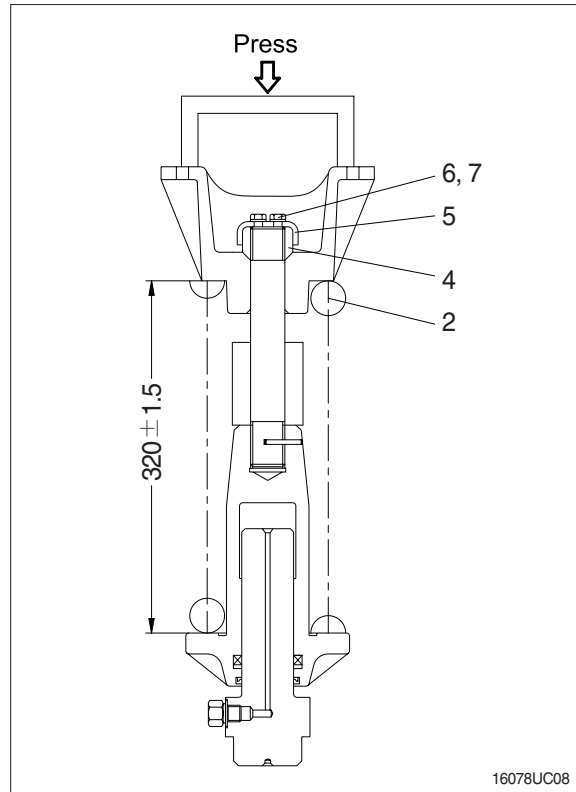



# GROUP 11 WORK EQUIPMENT

## 1. STRUCTURE

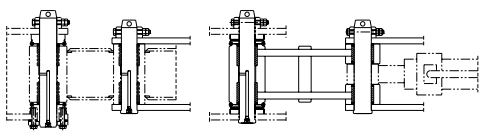
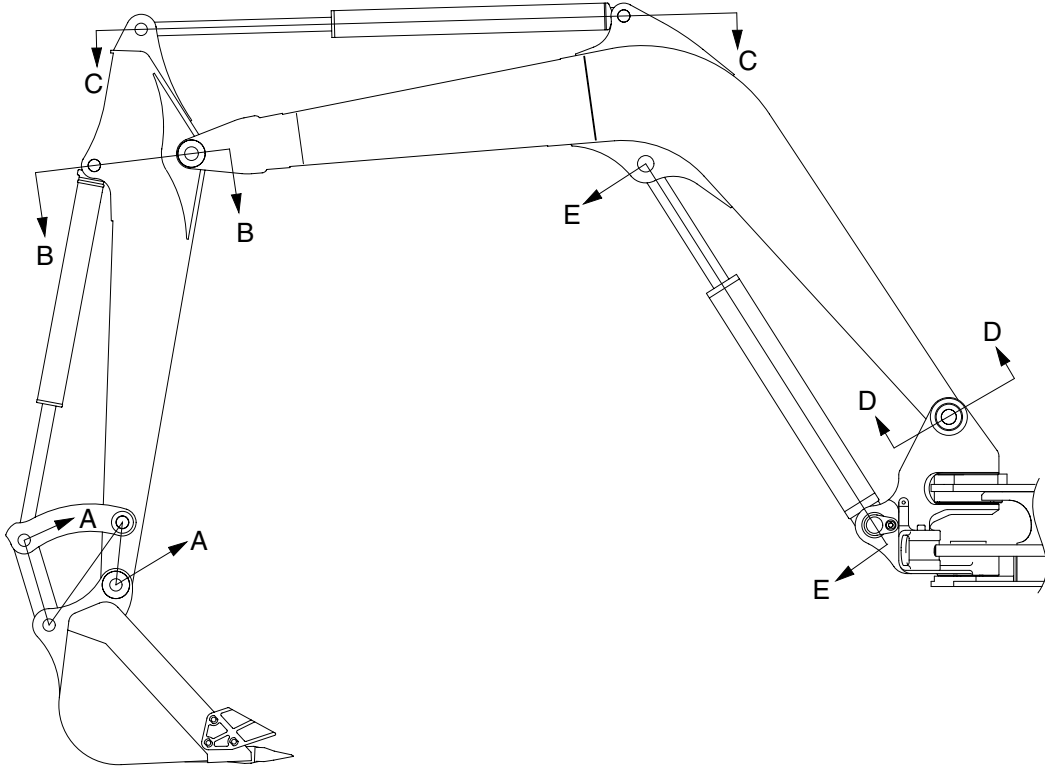

SECTION A-A

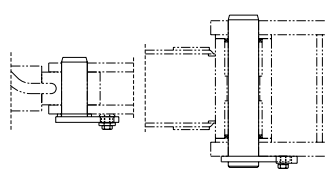

SECTION B-B

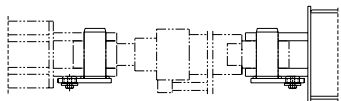

SECTION C-C

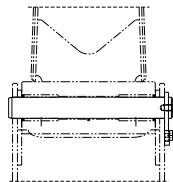

SECTION D-D

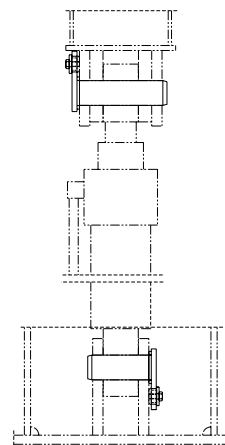

SECTION E-E

80CR97AT01

## 2. REMOVAL AND INSTALL

### 1) BUCKET ASSEMBLY

#### (1) Removal

- ① Lower the work equipment completely to ground with back of bucket facing down.

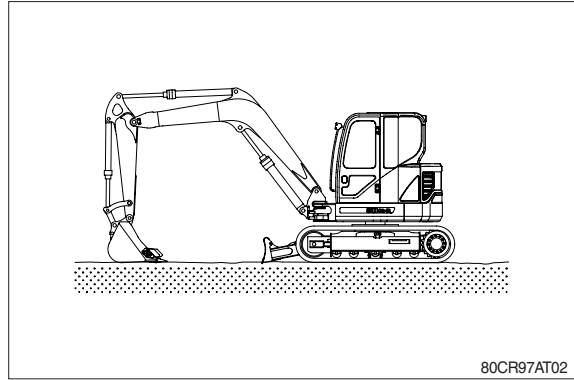

- ② Remove nut (1), bolt (2) and draw out the pin (4).

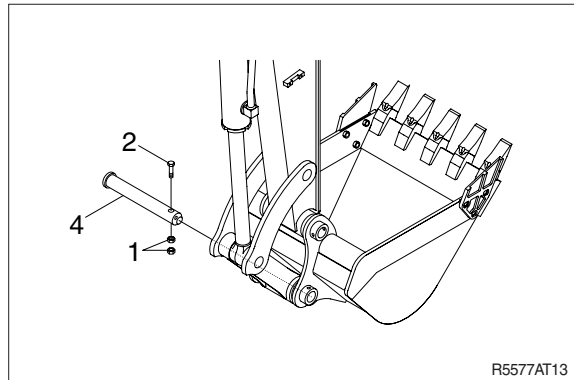

- ③ Remove nut (1), bolt (2) and draw out the pin (3) then remove the bucket assembly.  
· Weight : 230 kg (510 lb)

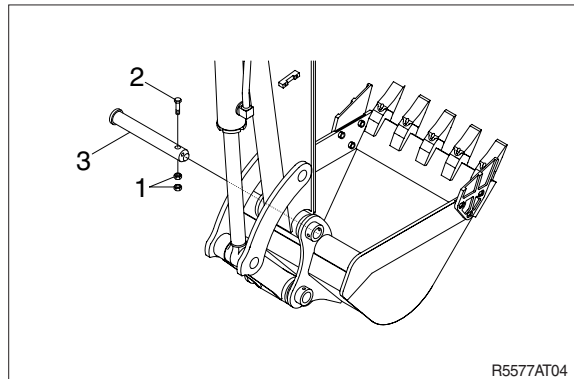

#### (2) Install

- ① Carry out installation in the reverse order to removal.

**▲** When aligning the mounting position of the pin, do not insert your fingers in the pin hole.

- ※ Adjust the bucket clearance.  
For detail, see operation manual.

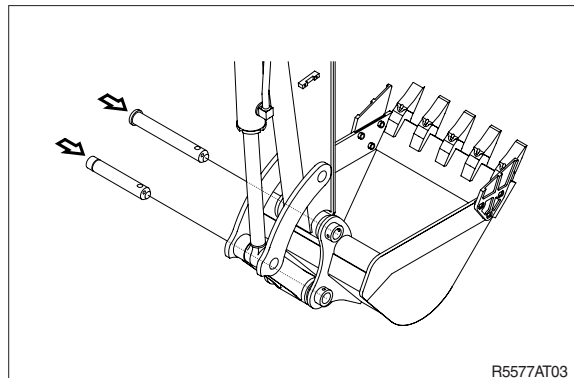

## 2) ARM ASSEMBLY

### (1) Removal

※ Loosen the breather slowly to release the pressure inside the hydraulic tank.

**▲ Escaping fluid under pressure can penetrate the skin causing serious injury.**

① Remove bucket assembly.

For details, see removal of bucket assembly.

② Disconnect bucket cylinder hose (4).

**▲ Fit blind plugs (5) in the piping at the chassis end securely to prevent oil from spurting out when the engine is started.**

③ Sling arm cylinder assembly, remove spring, pin stopper and pull out pin.

※ Tie the rod with wire to prevent it from coming out.

④ For details, see removal of arm cylinder assembly.

Place a wooden block under the cylinder and bring the cylinder down to it.

⑤ Remove bolt (1) and pull out the pin (2) then remove the arm assembly.

· Weight : 180 kg (400 lb)

※ When lifting the arm assembly, always lift the center of gravity.

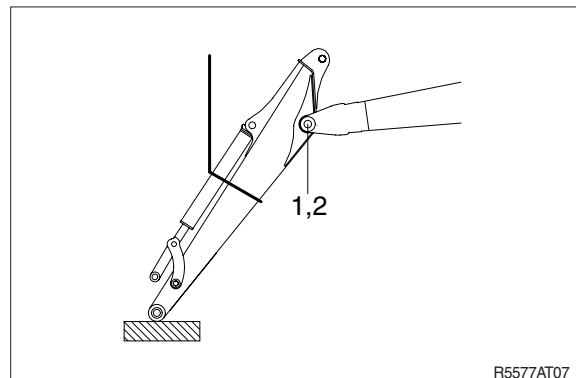
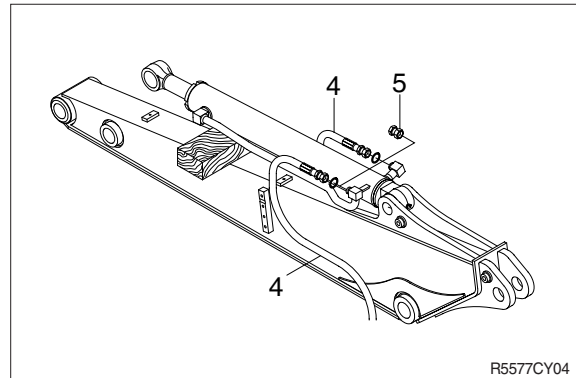
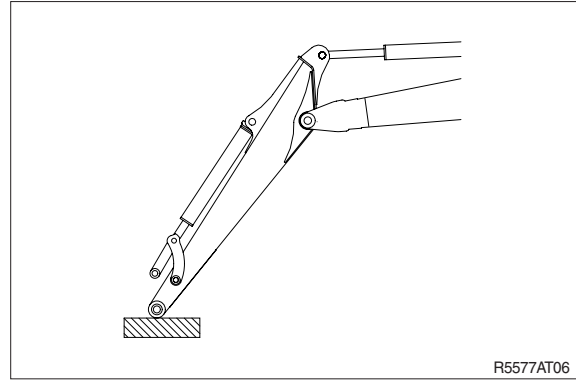

### (2) Install

① Carry out installation in the reverse order to removal.

**▲ When lifting the arm assembly, always lift the center of gravity.**

※ Bleed the air from the cylinder.

### 3) BOOM CYLINDER

#### (1) Removal

- ① Remove arm and bucket assembly.
- ② For details, see removal of arm and bucket assembly.  
Remove boom cylinder assembly from boom.  
For details, see removal of arm cylinder assembly.

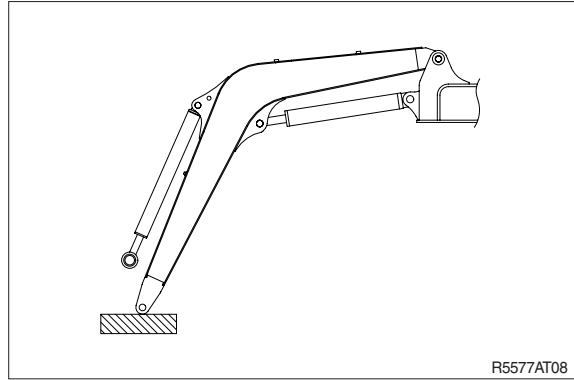

- ③ Disconnect head lamp wiring.
- ④ Disconnect bucket cylinder hose (2) and arm cylinder hose (1).  
※ When the hose are disconnected, oil may spurt out.
- ⑤ Sling boom assembly (3).

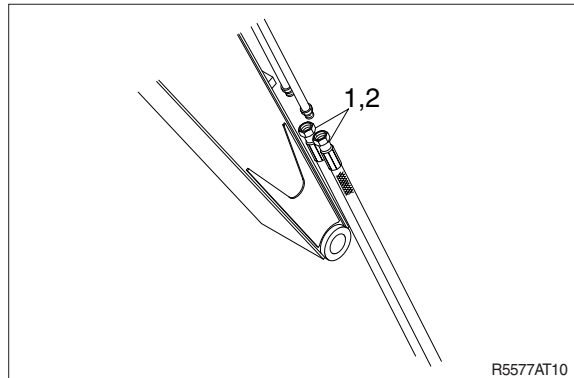

- ⑥ Remove bolt (3), nut (4) and pull out the pin (5) then remove boom assembly.  
· Weight : 420 kg (930 lb)  
※ When lifting the boom assembly always lift the center of gravity.

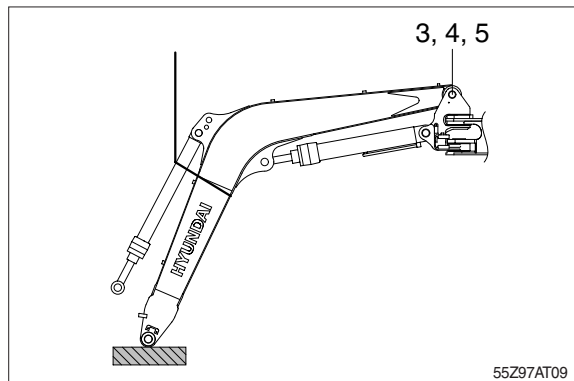

#### (2) Install

- ① Carry out installation in the reverse order to removal.
- ▲ When lifting the arm assembly, always lift the center of gravity.
- ※ Bleed the air from the cylinder.

