

SECTION 8 COMPONENT MOUNTING TORQUE

Group 1 Introduction guide	8-1
Group 2 Engine system	8-2
Group 3 Electric system	8-4
Group 4 Hydraulic system	8-5
Group 5 Undercarriage	8-7
Group 6 Structure	8-8
Group 7 Work equipment	8-10

SECTION 8 COMPONENT MOUNTING TORQUE

GROUP 1 INTRODUCTION GUIDE

1. This section shows bolt specifications and standard torque values needed when mounting components to the machine.
 2. Use genuine Hyundai spare parts.
We expressly point out that Hyundai will not accept any responsibility for defects resulted from non-genuine parts.
In such cases Hyundai cannot assume liability for any damage.
- ※ Only metric fasteners can be used and incorrect fasteners may result in machine damage or malfunction.
 - ※ Before installation, clean all the components with a non-corrosive cleaner. Bolts and threads must not be worn or damaged.

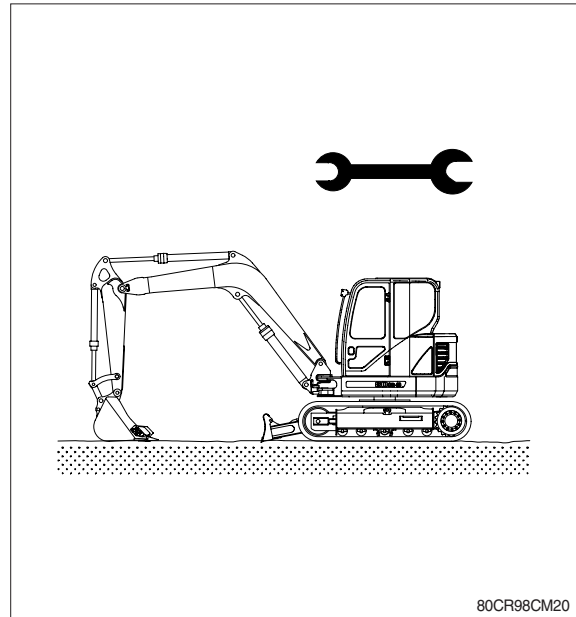

GROUP 2 ENGINE SYSTEM

1. ENGINE AND ACCESSORIES MOUNTING

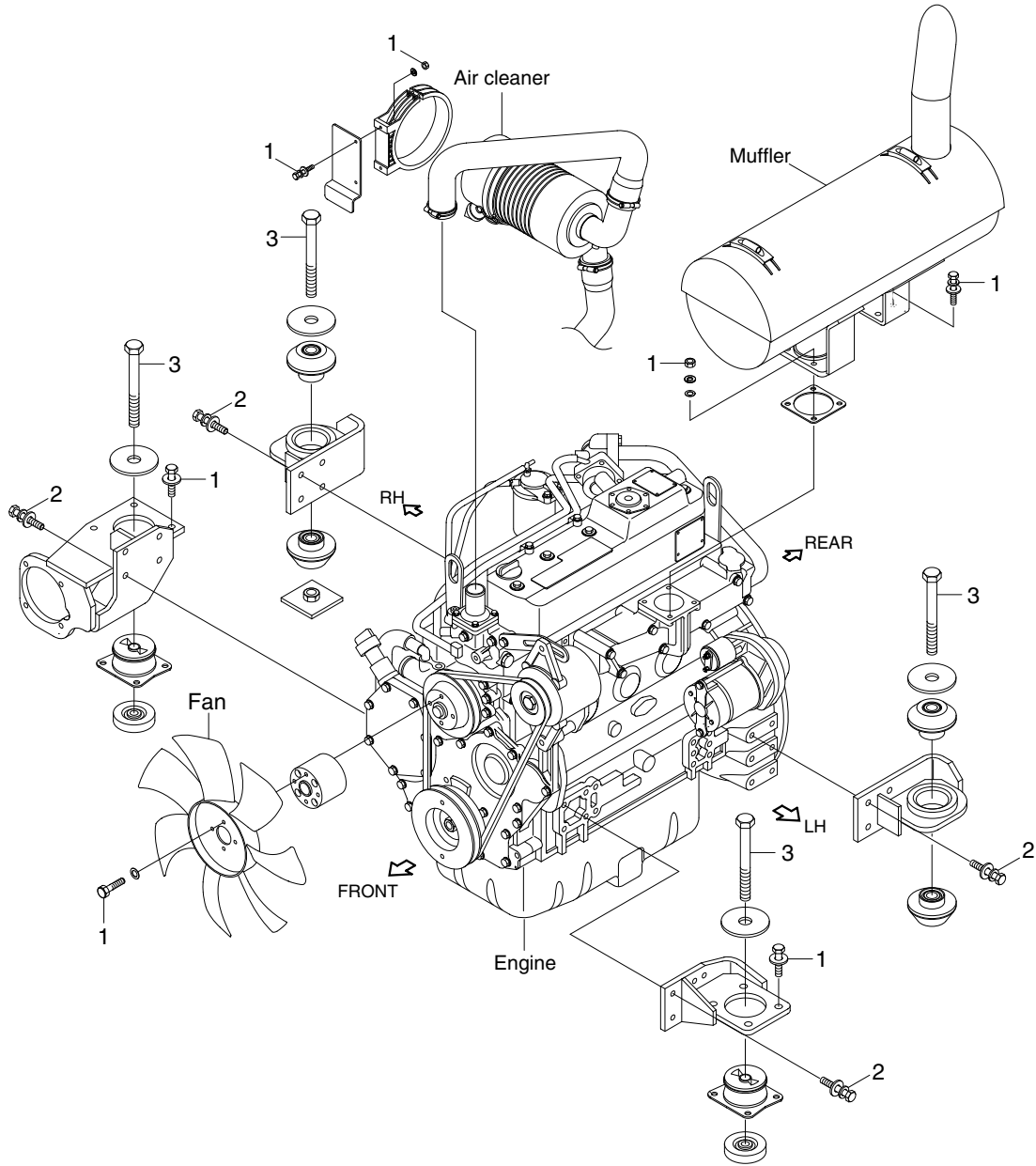

80CR98CM01

· Tightening torque

Item	Size	kgf · m	lbf · ft
1	M 8×1.25	2.5±0.5	18.1±3.6
2	M10×1.5	6.9±1.0	49.9±7.2

Item	Size	kgf · m	lbf · ft
3	M16×2.0	25±2.5	181±18

2. COOLING SYSTEM AND FUEL TANK MOUNTING

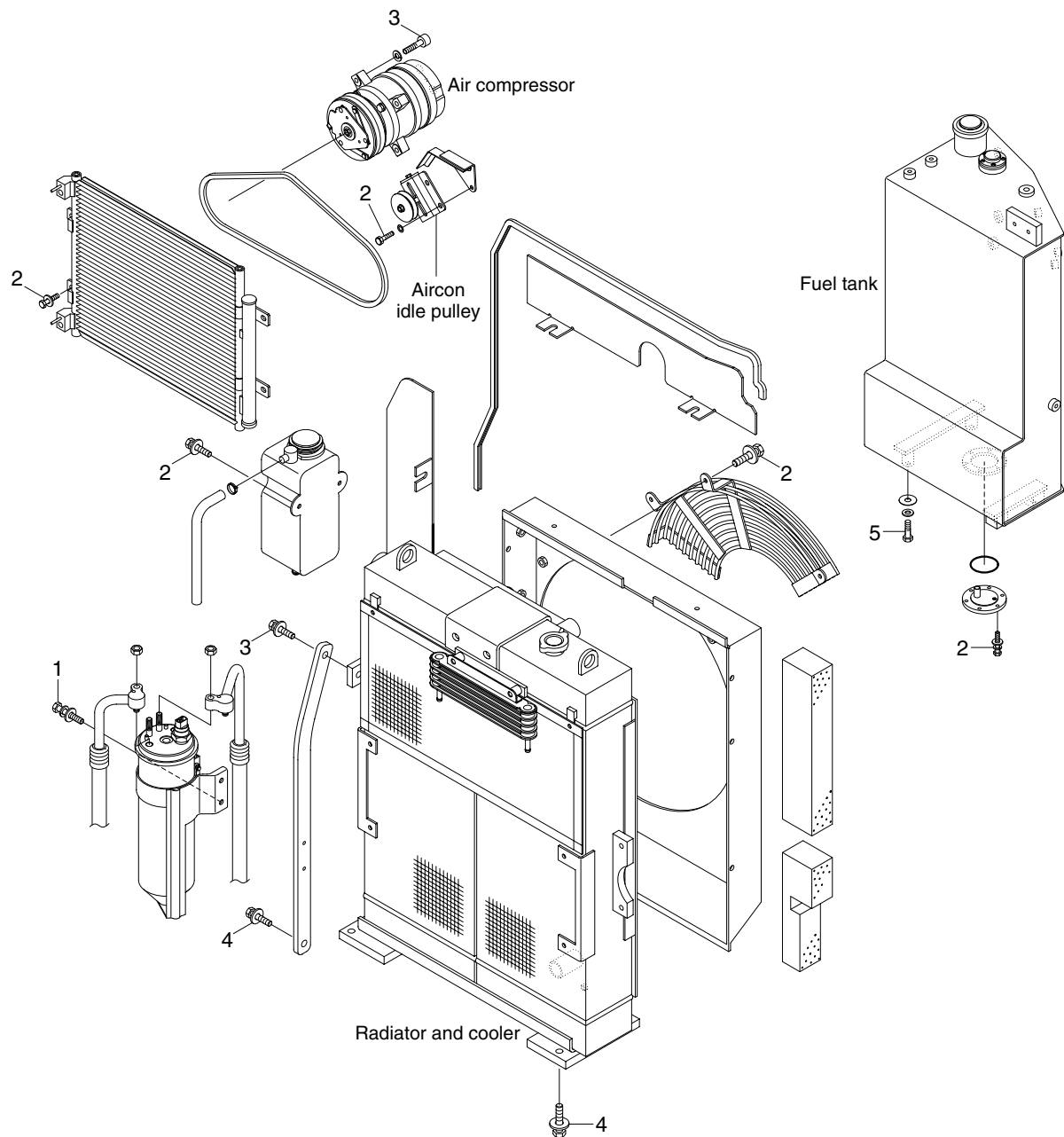

80CR98CM02

· Tightening torque

Item	Size	kgf · m	lbf · ft
1	M 6×1.0	1.05±0.2	7.6±1.45
2	M 8×1.25	2.5±0.5	18.1±3.6
3	M10×1.25	6.9±1.4	49.9±10.1

Item	Size	kgf · m	lbf · ft
4	M12×1.75	12.8±3.0	92.6±21.7
5	M16×2.0	25±2.5	181±18.1

GROUP 3 ELECTRIC SYSTEM

1. ELECTRIC COMPONENTS MOUNTING 1

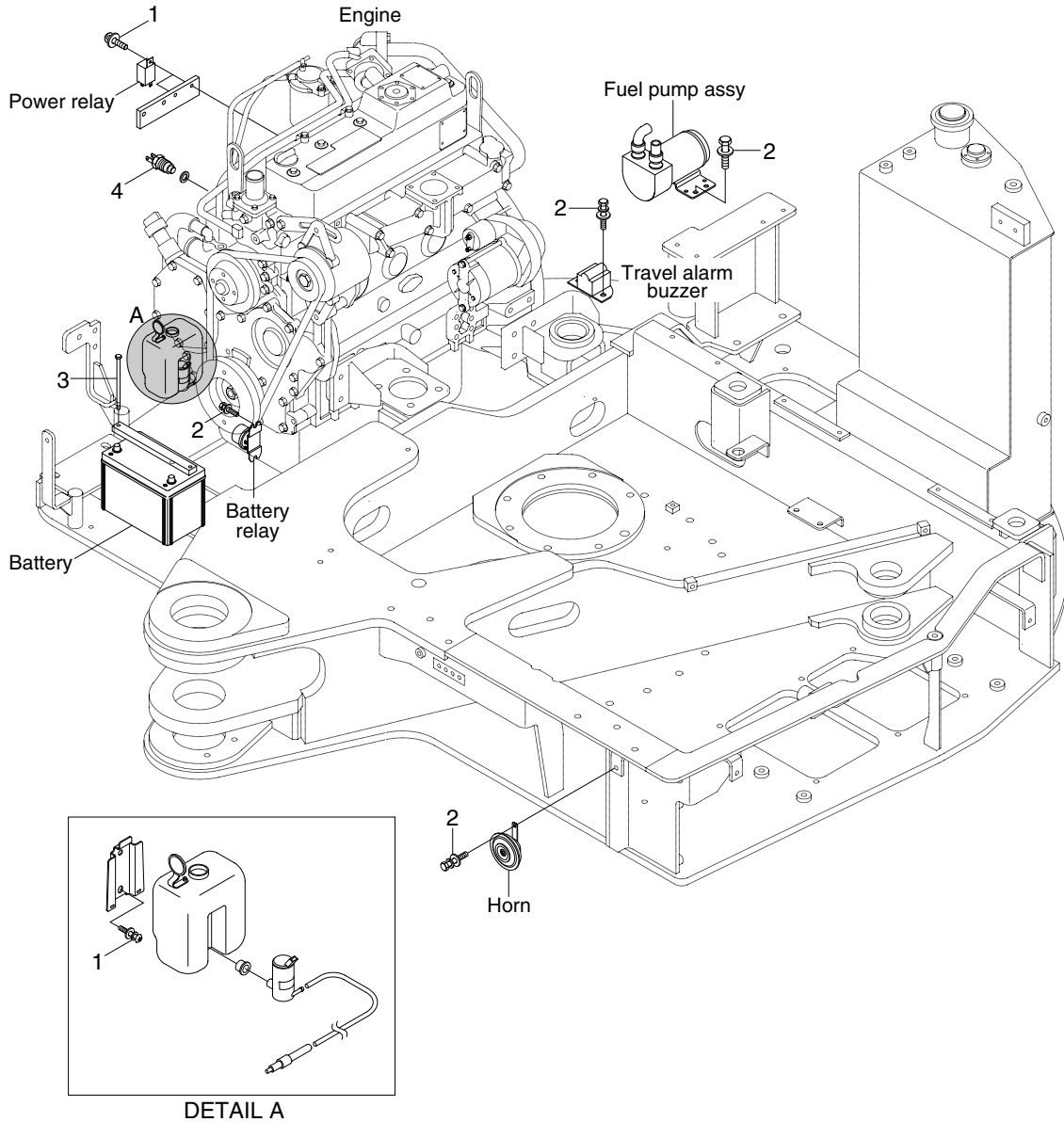

80CR98CM03

· Tightening torque

Item	Size	kgf · m	lbf · ft
1	M 6×1.0	1.05±0.2	7.6±1.45
2	M 8×1.25	2.5±0.5	18.1±3.6

Item	Size	kgf · m	lbf · ft
3	M10×1.5	6.9±1.4	49.9±10.1
4	-	2.0±0.2	14.5±1.4

GROUP 4 HYDRAULIC SYSTEM

1. HYDRAULIC COMPONENTS MOUNTING 1

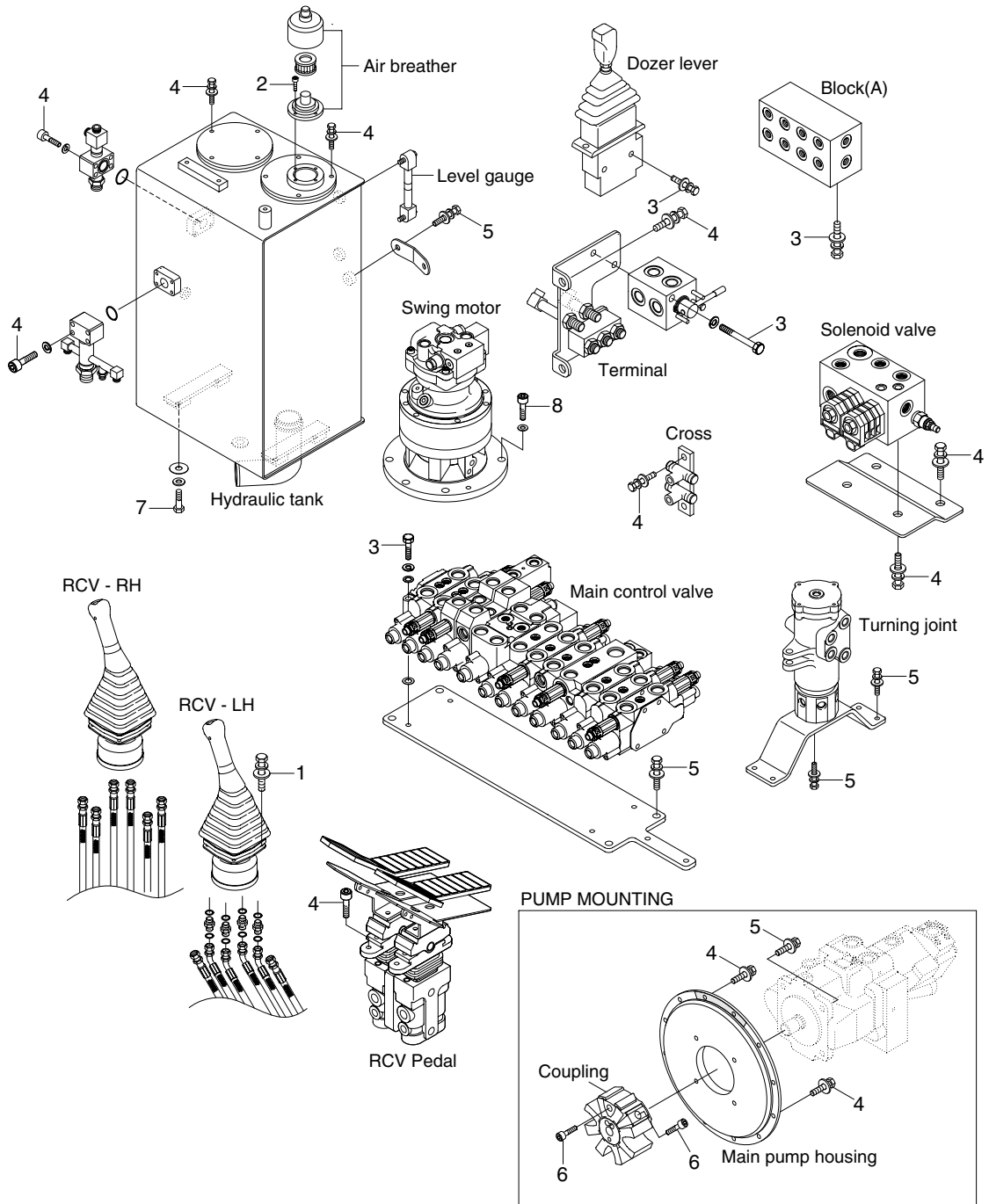

80CR98CM05

· Tightening torque

Item	Size	kgf · m	lbf · ft
1	M 6×1.0	1.05±0.2	7.6±1.45
2	M 6×1.0	1.44±0.3	10.4±2.2
3	M 8×1.25	2.5±0.5	18.1±3.6
4	M10×1.5	6.9±1.4	49.9±10.1

Item	Size	kgf · m	lbf · ft
5	M12×1.75	12.2±1.3	88.2±9.4
6	M14×2.0	14.0±1.0	101±7.2
7	M16×2.0	25.0±2.5	118±18.1
8	M16×2.0	29.7±4.5	215±33.0

2. HYDRAULIC COMPONENTS MOUNTING 2

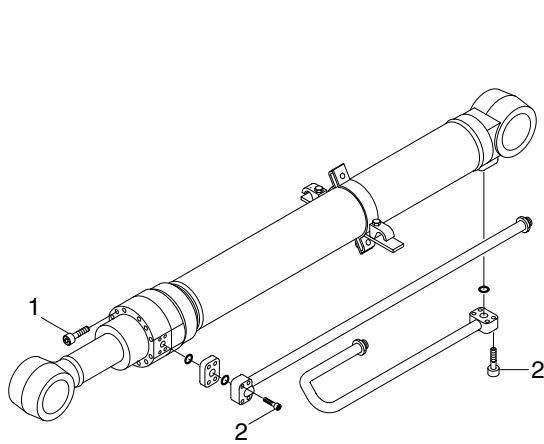

BOOM CYLINDER

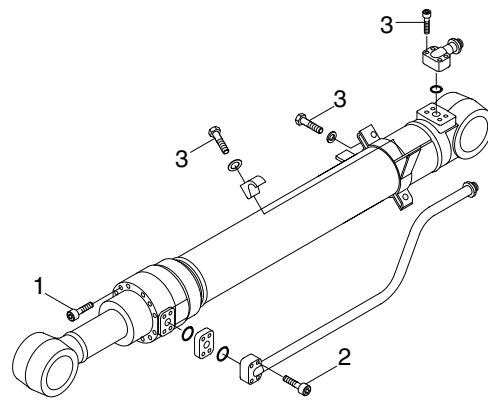

ARM CYLINDER

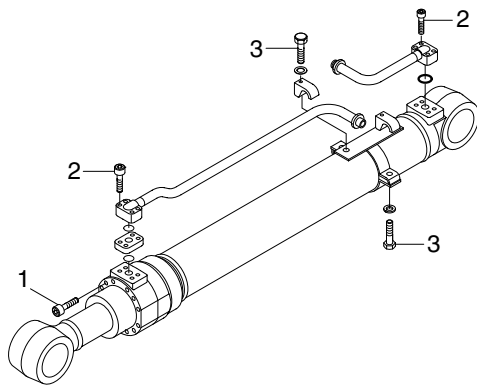

BUCKET CYLINDER

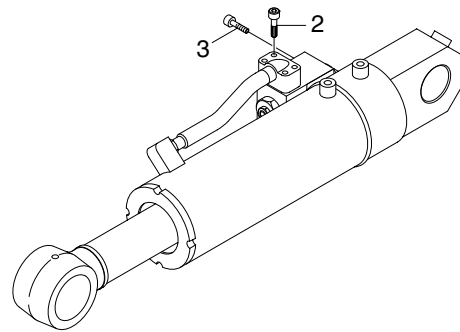

DOZER CYLINDER

80CR98CM06

· Tightening torque

Gland mounting bolt (1)

Item	Size	kgf · m	lbf · ft
Boom cylinder	M14	15 ± 1.5	108 ± 10.8
Arm cylinder	M14	15 ± 1.5	108 ± 10.8
Bucket cylinder	M12	9.4 ± 1.0	68 ± 7.2

Item	Size	kgf · m	lbf · ft
2	M8 × 1.25	2.7 ± 0.3	19.5 ± 2.2
3	M10 × 1.5	3.2 ± 0.3	23.1 ± 2.2

GROUP 5 UNDERCARRIAGE

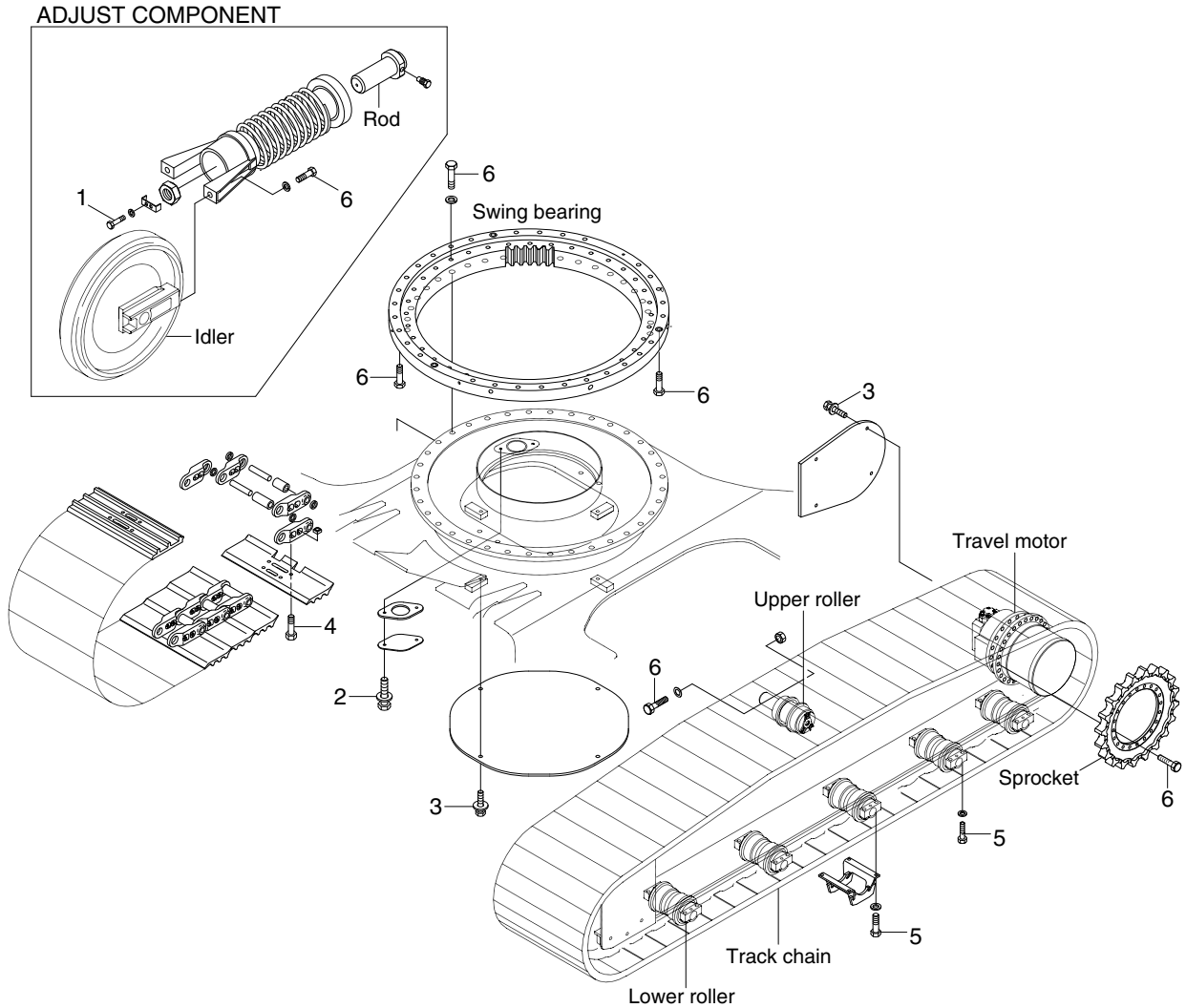

80CR98CM08

· Tightening torque

Item	Size	kgf · m	lbf · ft
1	M8×1.25	3.4±0.5	24.6±3.6
2	M10×1.5	6.9±1.4	49.9±10.1
3	M12×1.75	12.8±3.0	92.6±21.7

Item	Size	kgf · m	lbf · ft
4	M14×1.5	25.5±2.5	184±18.1
5	M14×2.0	19.6±2.0	142±14.5
6	M16×2.0	29.7±4.3	215±31.1

GROUP 6 STRUCTURE

1. CAB AND ACCESSORIES MOUNTING

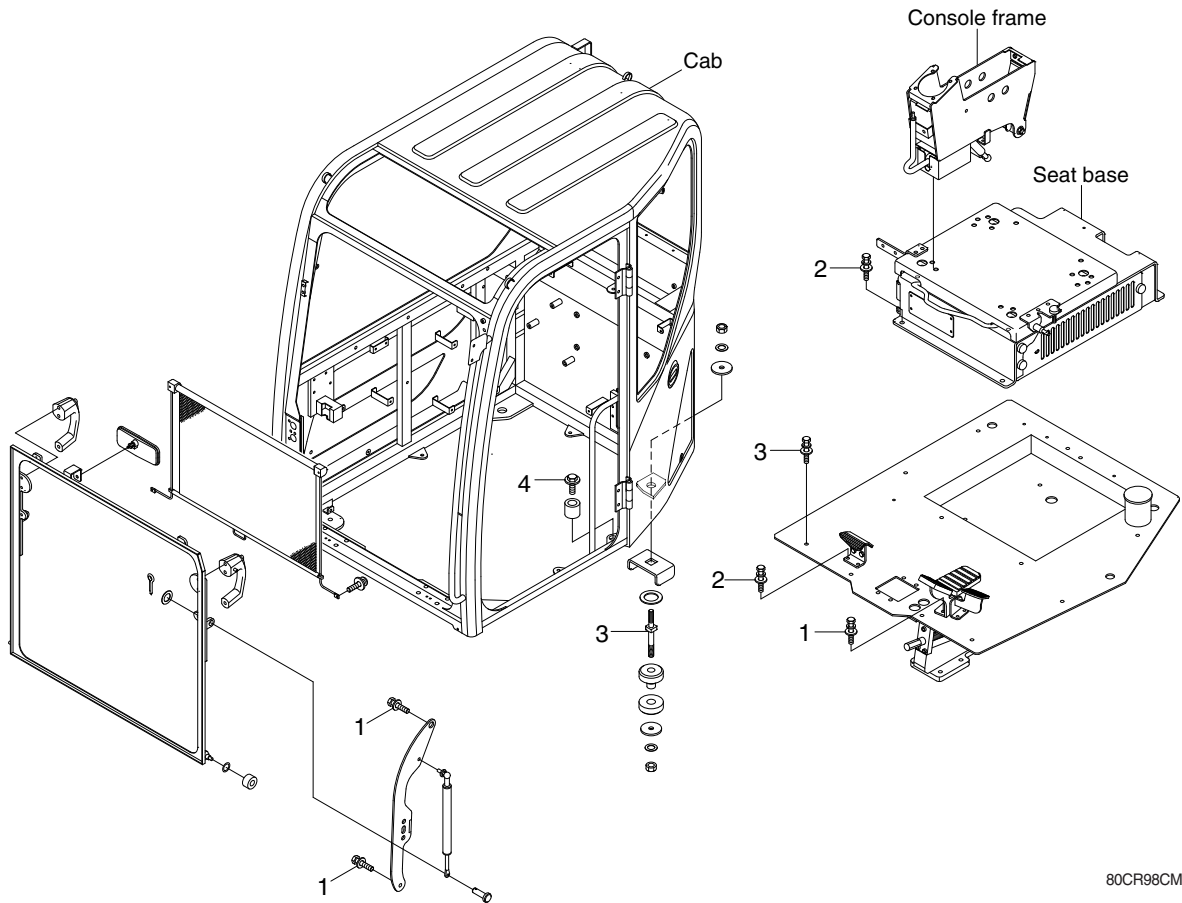
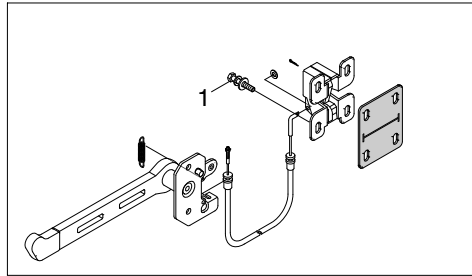

80CR98CM09

· Tightening torque

Item	Size	kgf · m	lbf · ft
1	M 8×1.25	2.5±0.5	18.1±3.6
2	M10×1.5	4.7±0.9	34.0±6.5

Item	Size	kgf · m	lbf · ft
3	M12×1.75	12.8±3.0	92.6±21.7
4	M16×2.0	29.7±4.5	215±32.5

2. COWLING MOUNTING

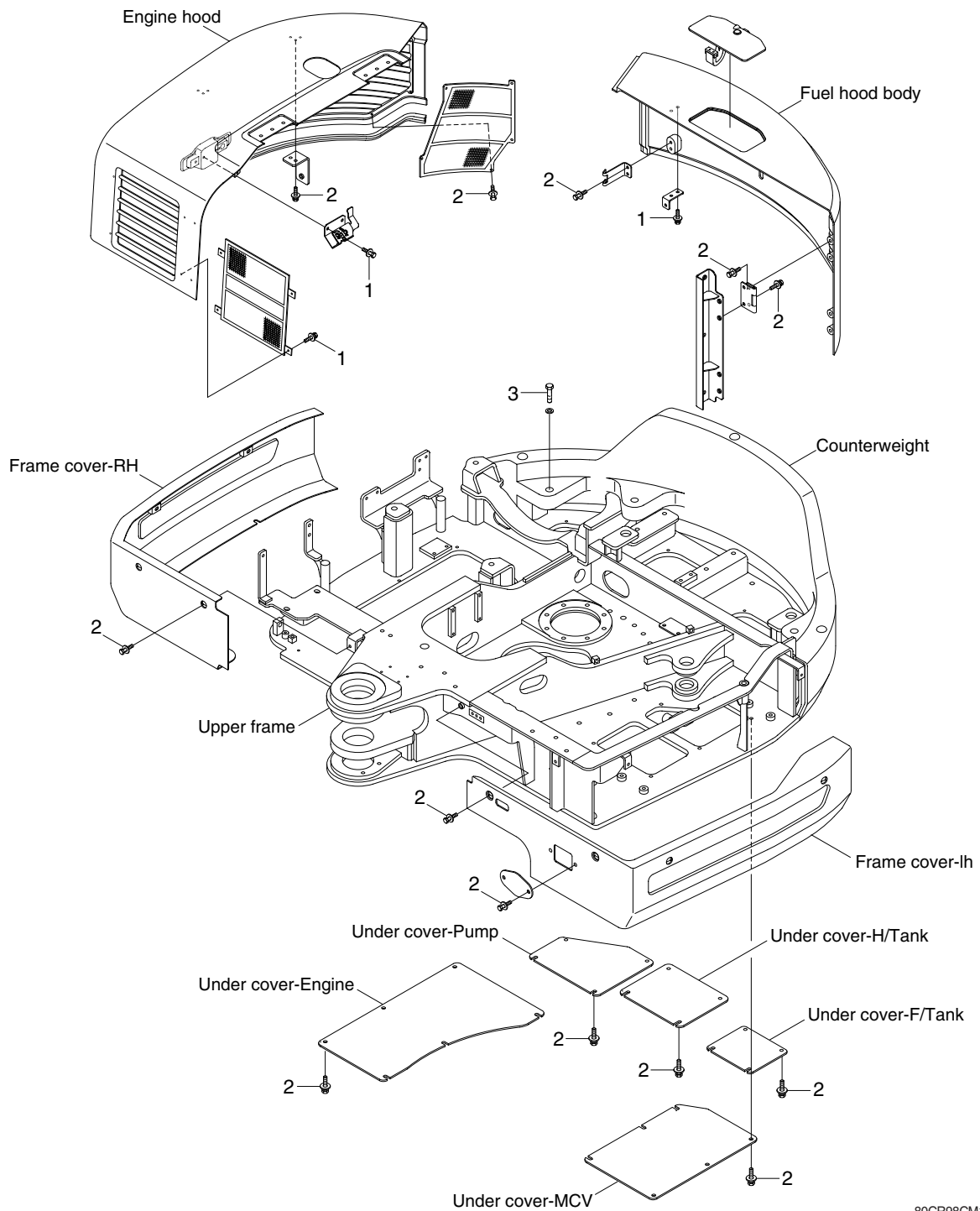

80CR98CM11

· Tightening torque

Item	Size	kgf · m	lbf · ft
1	M 8×1.25	2.5±0.5	18.1±3.6
2	M10×1.5	6.9±1.4	49.9±10.1

Item	Size	kgf · m	lbf · ft
3	M27×3.0	140±15	1013±108

GROUP 7 WORK EQUIPMENT

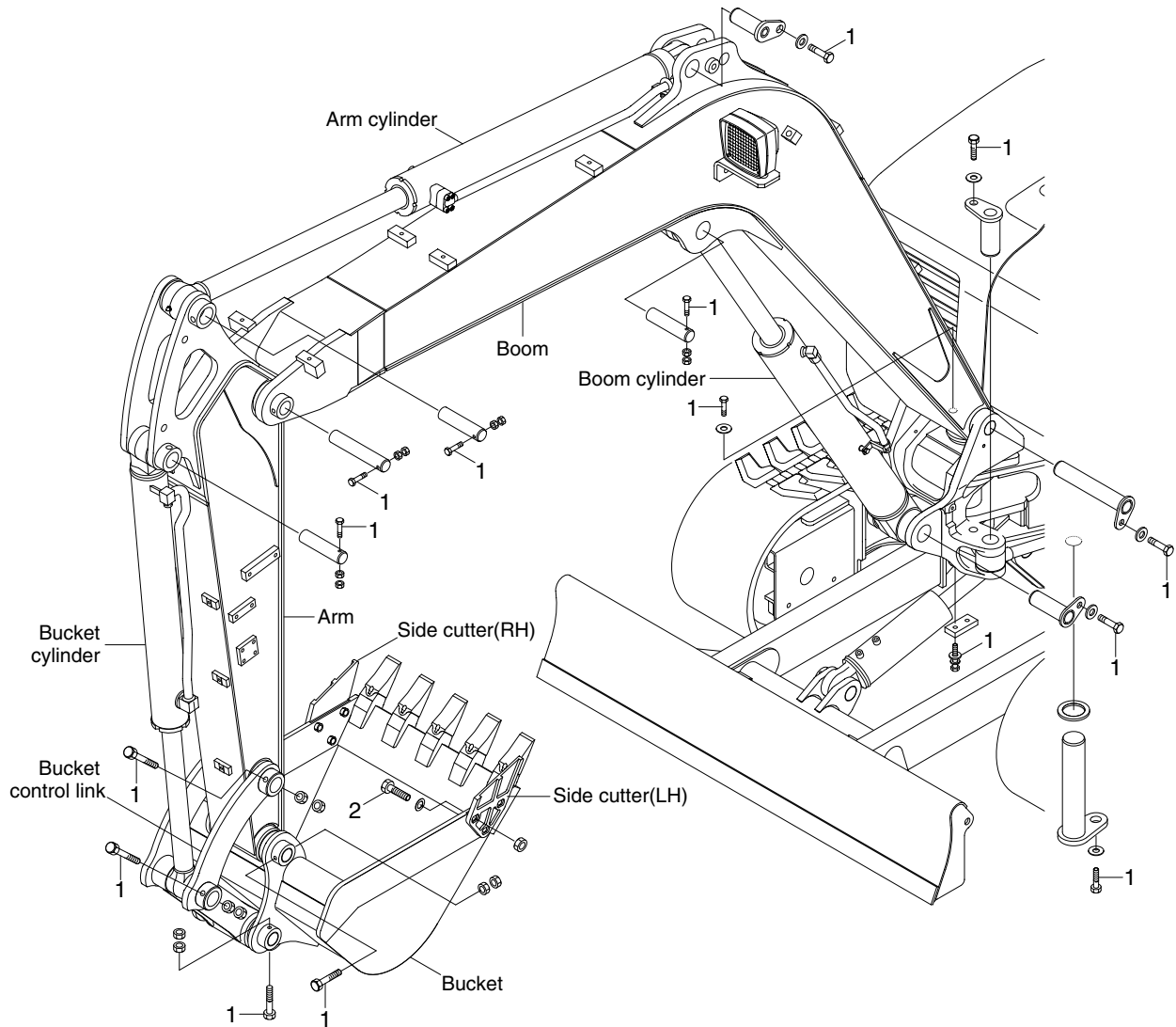

80CR98CM12

• Tightening torque

Item	Size	kgf · m	lbf · ft
1	M12×1.75	12.8±3.0	92.6±21.7

Item	Size	kgf · m	lbf · ft
2	M20×2.5	57.9±8.7	419±62.9