

GROUP 2 ENGINE SYSTEM

ENGINE AND ACCESSORIES MOUNTING

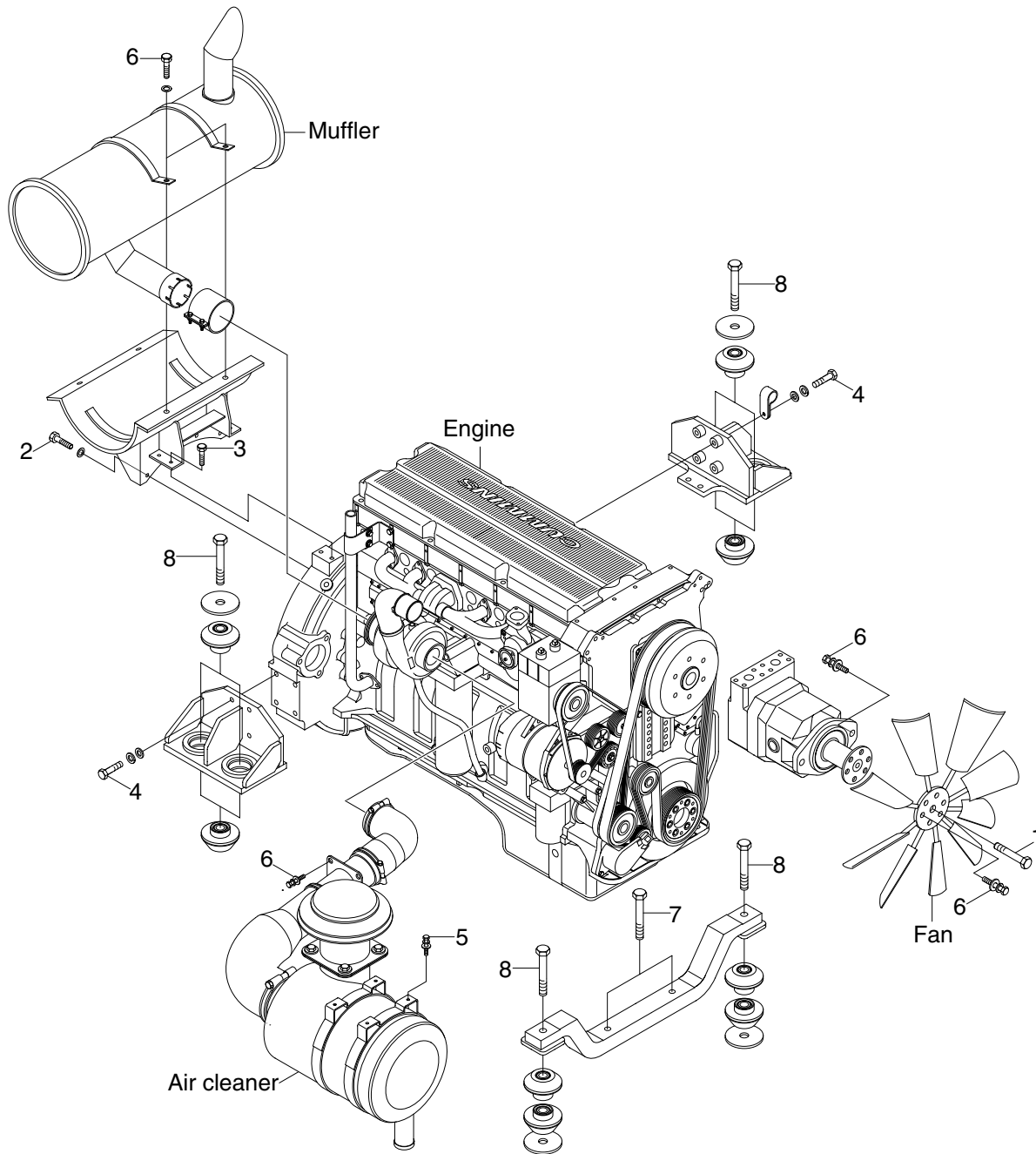

8007ACM16

· Tightening torque

Item	Size	kgf · m	lbf · ft
1	5/16-18UNC	3.5±0.4	25.3±2.9
2	M 8×1.25	13.4±1.34	96.9±9.7
3	M 8×1.25	2.5±0.5	18.1±3.6
4	5/8-11UNC	26.1±2.6	188.8±18.8

Item	Size	kgf · m	lbf · ft
5	M10×1.5	6.9±1.4	49.9±10.1
6	M12×1.75	12.8±3.0	92.6±21.7
7	M20×2.5	57.9±8.7	419±62.9
8	M24×3.0	88.2±8.8	638±63.7

COOLING SYSTEM AND FUEL TANK MOUNTING

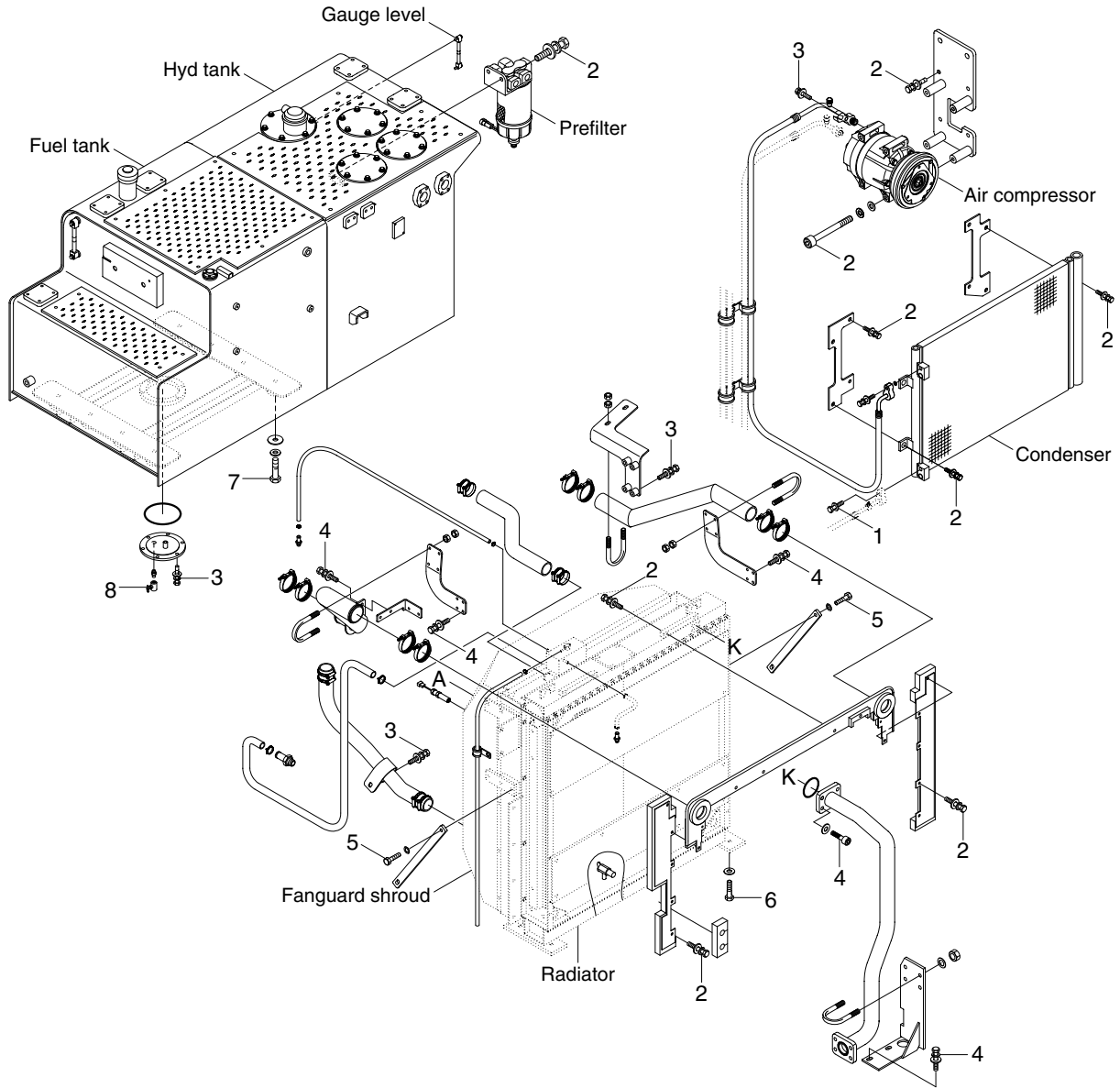

80099CM02

· Tightening torque

Item	Size	kgf · m	lbf · ft
1	M 6×1.0	1.05±0.2	7.6±1.45
2	M 8×1.25	2.5±0.5	18.1±3.6
3	M10×1.5	6.9±1.4	49.9±10.1
4	M12×1.75	12.8±3.0	92.6±21.7

Item	Size	kgf · m	lbf · ft
5	M14×2.0	19.6±2.9	141.8±21
6	M16×2.0	29.7±4.4	214.8±31.8
7	M20×2.5	58±6.0	420±43.4
8	-	2.3±0.6	16.6±4.3