

SECTION 2 STRUCTURE AND FUNCTION

Group 1 Pump Device	2-1
Group 2 Main Control Valve	2-9
Group 3 Swing Device	2-28
Group 4 Travel Device	2-38
Group 5 RCV Lever	2-45
Group 6 RCV Pedal	2-52

SECTION 2 STRUCTURE AND FUNCTION

GROUP 1 HYDRAULIC PUMP

1. GENERAL

This is a variable displacement double-piston pump for discharge with equal displacements from one cylinder block. This pump is so compact as to appear a single pump though this is actually a double pump.

Because this pump has one swash plate, the tilting angle is the same for two pumps. Tilting of the pump changes in response to the total pressure of P1 + P2. Namely, the output is controlled to the constant value so that the relationship between the discharge pressure and flow rate Q becomes constant, $(P1 + P2) * Q = \text{Constant}$.

The third pump and pilot pump can be connected to the same shaft via a coupling.

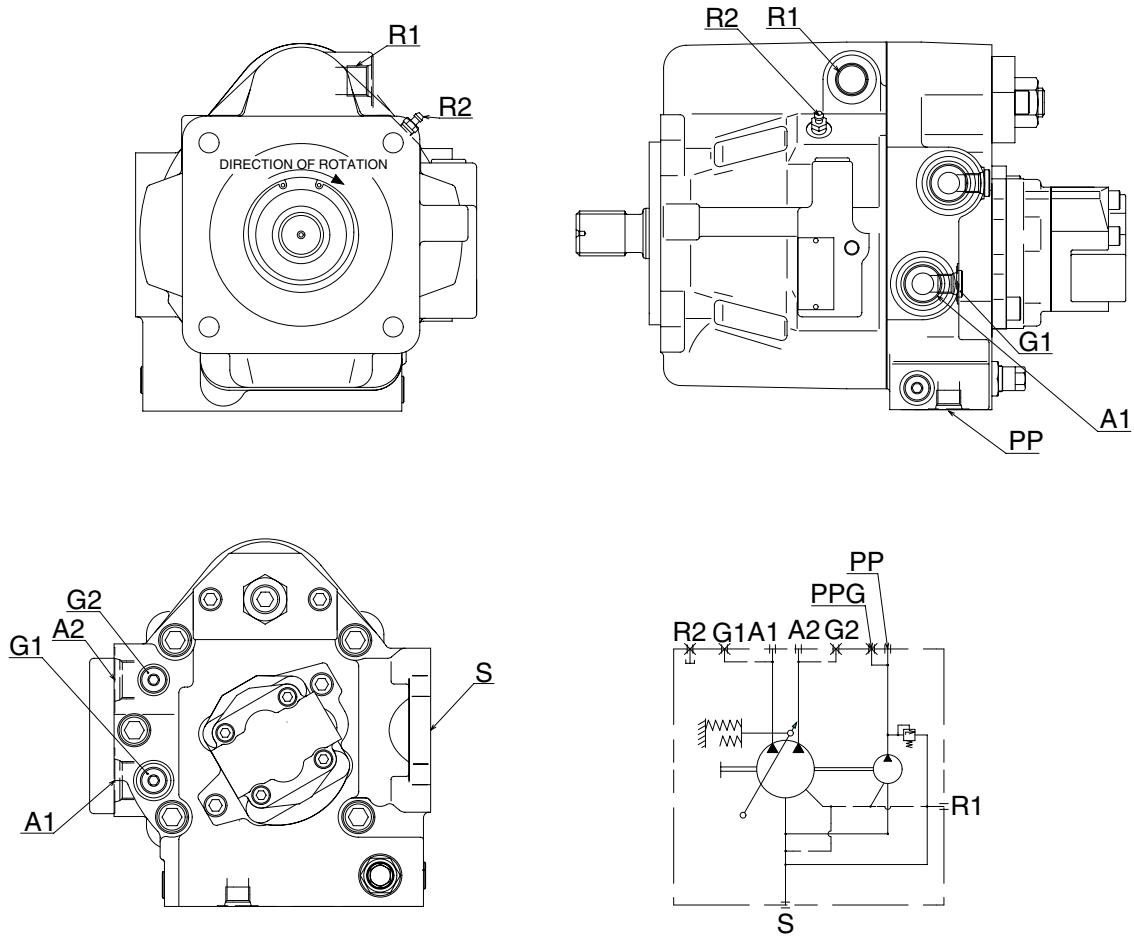

RD8072MP01

Description of the ports

Port	Name	Bore
S	Suction port	SAE 2 1/2 (Standard)
A1, A2	Discharge port	PF 3/4
PP	Pilot port	G 3/8
G1, G2	Gauge port	PF 1/4 With quick coupler
R1	Drain port	G 1/2
R2	Air bleeder port	With bleeder valve (M10× 1.0)

2. PRINCIPAL COMPONENTS AND FUNCTIONS

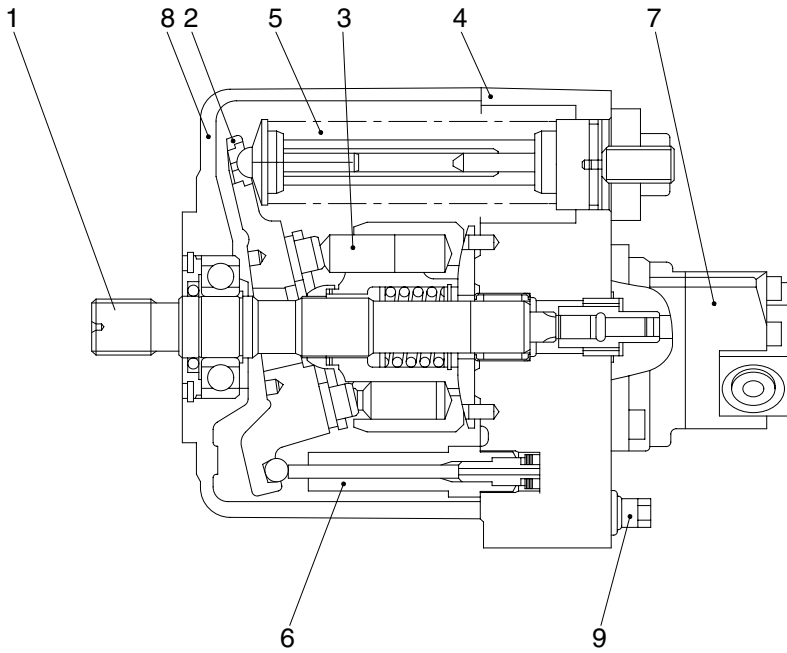

7072MP03

- | | | | |
|---|-------------------------|---|-------------------------|
| 1 | Shaft assembly | 6 | Control piston assembly |
| 2 | Swash plate assembly | 7 | Gear pump |
| 3 | Rotary group | 8 | Housing |
| 4 | Cover assembly | 9 | Relief valve |
| 5 | Control spring assembly | | |

This is a variable displacement double-piston pump for discharge with two equal displacements from one cylinder block. Because this is one rotary group, there is only one suction port. The oil is divided into two equal flows by the control plate in the cover and directed to two discharge ports provided in the cover. The discharge pressure directed to the control piston tilts the hanger by overcoming the spring force. Since the piston stroke changes according to the tilting angle of the hanger, the flow can be changed. The simultaneous tilting angle constant-output control method is employed. The pilot pump can be connected to the same shaft via a coupling.

1) PRINCIPLE OF OPERATION

(1) Function of pump

Displacement $q(\text{cm}^3)$

$$q = \pi \times d^2/4 \times \tan \alpha \times D \times Z/2 \times 10^3$$

$\tan \alpha \times D$: Strokes

Z : Number of piston

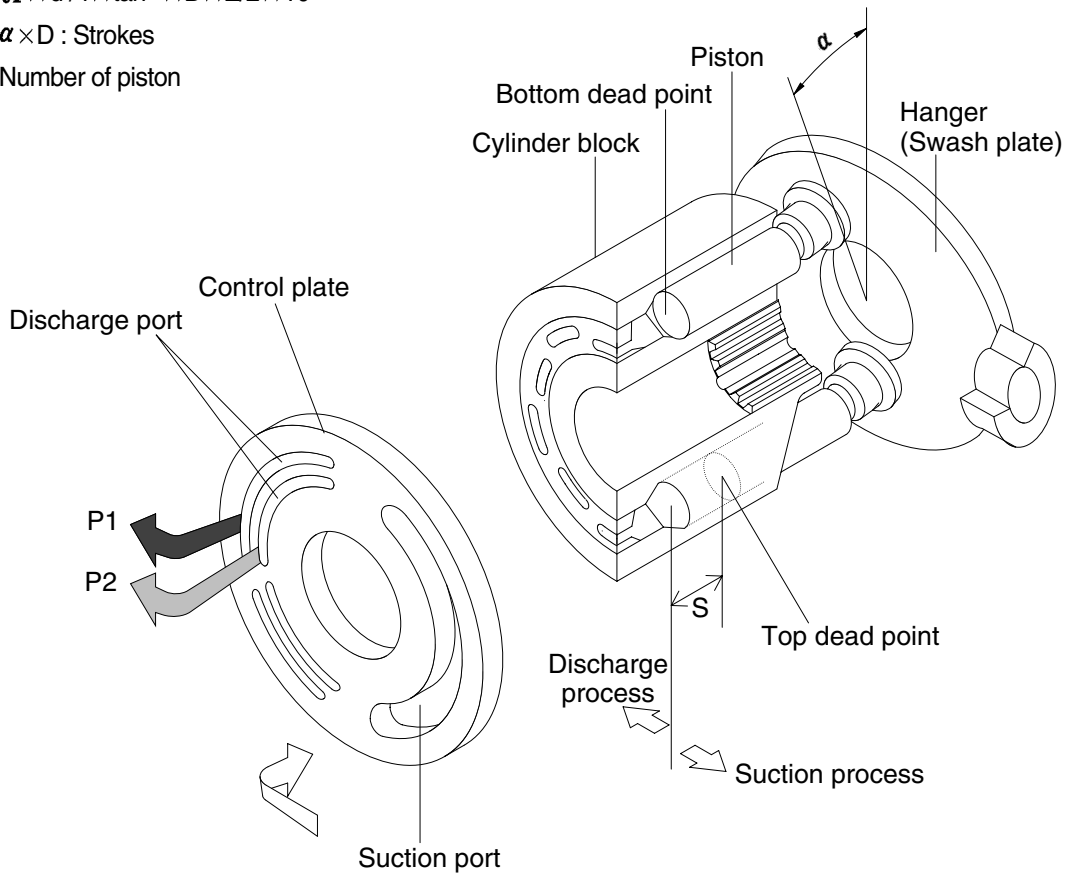

7072MP05

The cylinder block is connected via spline and can rotate together with the drive shaft.

The piston assembled into the cylinder block performs reciprocal operation while following the swash plate on the hanger.

The piston moves in a direction to increase the displacement during a stroke from the lower to the upper dead points. The oil flows from the suction port via a port plate into the cylinder block (suction process).

During a stroke from the upper to the lower dead points, the piston moves in a direction to decrease the displacement. The oil is discharged to the discharge port (discharge process).

The displacement can be changed by changing the tilting of the hanger (swash plate).

The oil sucked through the port in the cylinder block is discharged from the discharge port in the port plate.

The oil sucked through the port on the outside of the cylinder block is discharged from the discharge port on the outside of the port plate.

2) CONTROL FUNCTIONS

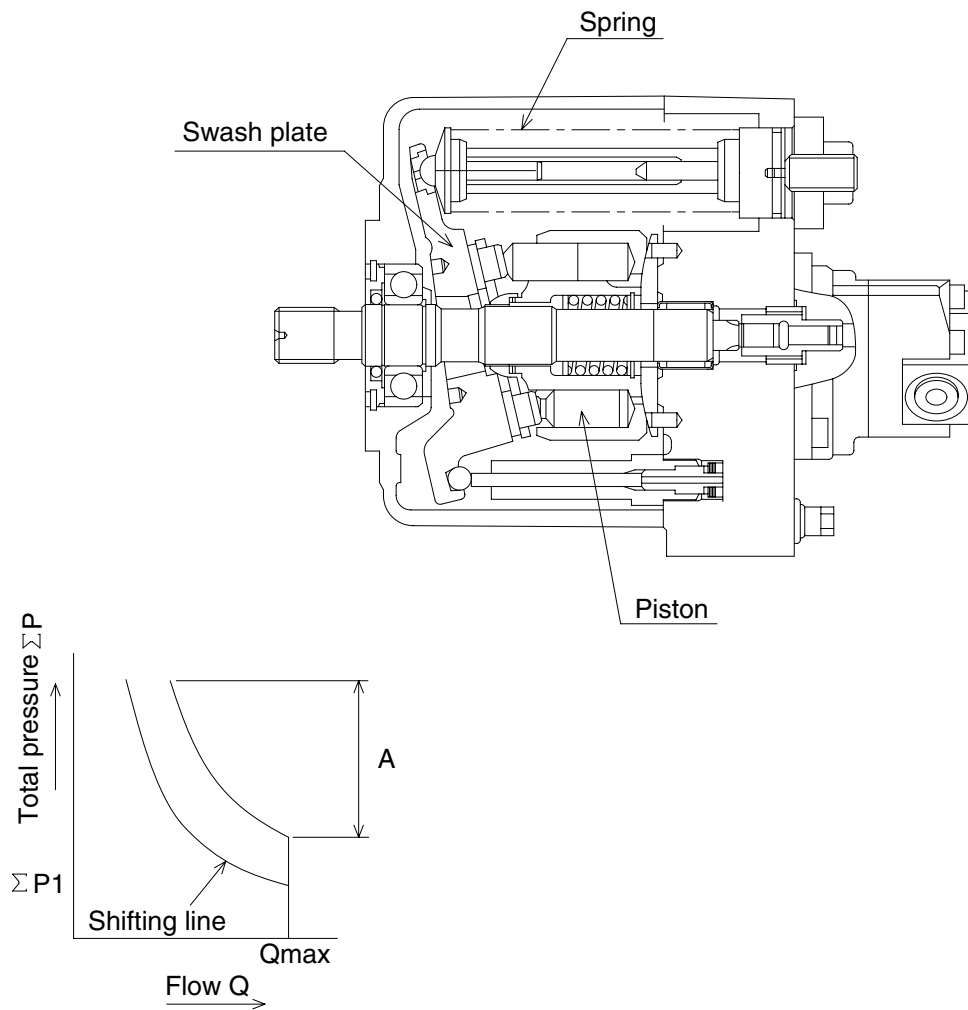

7072MP04

The delivery pressure P_1 and P_2 are directed to the piston which slides on the swash plate and acts on the swash plate.

The spring is provided to act against the delivery pressure.

When the oil pressure via piston acting on the swash plate is less than the installation load of the spring the swash plate is fixed to the maximum tilting position.

When the oil pressure via piston acting on the swash plate exceeds the installation load of the spring the swash plate is tilted and kept tilted at a position where the oil pressure is balanced with the spring force. (Region A in above figure)

3) CONTROL / ADJUSTMENT PROCEDURE

- (1) Loosen the hexagonal nut.
- (2) Tighten or loosen the adjusting screw to set the power shifting line.

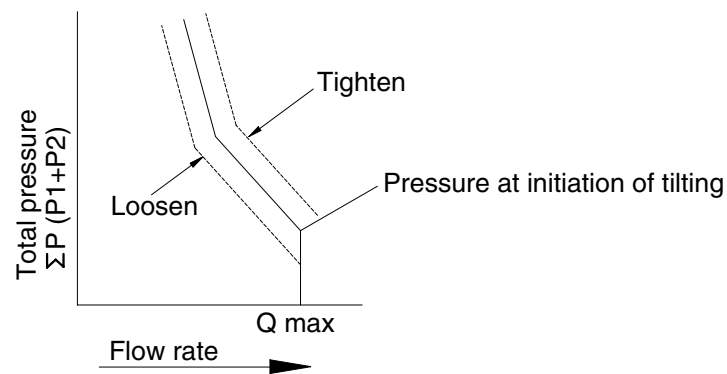
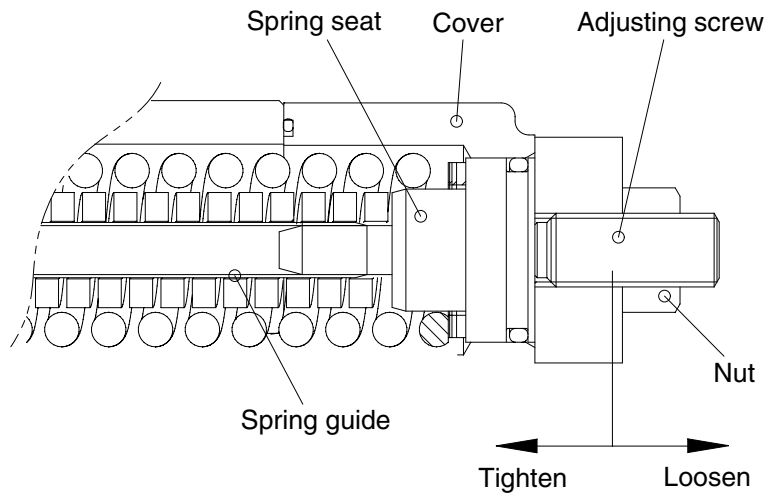

7072MP06

3. ADJUSTMENT

This hydraulic pump has been set and inspected according to your specified input power and control. Readjustment of all the adjusting portions may lead to the loss of functions specified for each control and the pump proper may be excluded from the scope of guarantee. Never attempt operating the adjusting screw, etc.

4. INSTALLATION

- (1) Install the pump so that the input shaft becomes horizontal.
- (2) Install the pump in a position lower than the lowest oil level in the tank to allow continuous flow of the oil into the pump.
- (3) Since the pump is installed directly to the diesel engine, always use a flexible hose. Install the suction pipe firmly to prevent suction of an air.
- (4) Use the high-pressure type flexible hoses for the discharge ports A1~A2.
- (5) After installation, fill the pump housing with the hydraulic oil.
- (6) Do not direct the external drain piping from within the oil.

5. DRIVE

- (1) Use a flexible coupling for connection to the motor.
- (2) Insert the coupling firmly onto the input shaft. Do not hammer the coupling during insertion.
- (3) The input shaft must rotate clockwise when viewed from the shaft end.

6. HYDRAULIC OIL

The hydraulic oil to be used must be a general petroleum, hydraulic oil or wear-resistant hydraulic oil (ISO 3448, VG 32~56 or equivalent).

The applicable viscosity range is as follows :

Maximum allowable viscosity : 1000 mm²/s

Minimum allowable viscosity : 10 mm²/s

Recommended viscosity range : 15 ~ 150 mm²/s

7. STARTING PROCEDURE

※ Before start up, check the following points and observe the cautions :

- (1) Check if the tank has been washed clean.
- (2) Check if the piping is clean and installed in such a manner as to prevent stress on the pump.
- (3) Check if the piping is connected correctly according to the piping (circuit) diagram.
- (4) Check if the joint and flange are correctly tightened.
- (5) Check if the joint between the motor and pump is correctly installed.
- (6) Check if the motor rotation direction agrees with the pump rotation direction.
- (7) Check if the specific hydraulic oil is supplied through the filter and filled in the tank to the specified position of the oil level galle.
- (8) Check if the filter has the specified filtration accuracy (10 μm or less).
- (9) Check if the filter has been installed correctly relative to the flow direction.
- (10) Check if the pump housing is filled with oil.
- (11) Check if the control valve is set to the bypass position.
- (12) Start the motor. If necessary, carry out warm-up operation at low speed.
- (13) Check, without any load on the system, if the actuator operates correctly.

- (14) When the motor has reached the operation speed, check the operation while applying the load to the actuator.
- (15) Check the monitoring or measuring instrument if installed.
- (16) Check the noise level.
- (17) Check the oil level in the tank. Supply the oil. If required.
- (18) Check the setting of the pressure control valve while applying the load to the actuator.
- (19) Check the parts for any leakage.
- (20) Stop the motor.
- (21) Retighten all the bolts and plugs even when they have proved to be free from Leakage.
(Be sure to remove the pressure from the circuit before retightening.)
- (22) Check the oil level in the tank.
- (23) Check if the pump and actuator function correctly.
- (24) Irregular operation of the actuator indicates that an air is left still in the circuit. When the air is bled completely from the circuit, all the parts operate smoothly without any irregular movement and there is no bubble in the oil of the tank.
- (25) Check the oil temperature.
- (26) Stop the motor.
- (27) Check the filter if the element is fouled.
- (28) If the element is heavily fouled, carry out flashing in the circuit.

※ To prevent damage to the pump, be sure to observe the following cautions during the operation which may allow entry of the actuator, hydraulic oil change, etc. :

- (1) After oil supply, fill the pump housing with the hydraulic oil.
- (2) Start the pump with the speed of 1000 rpm or less and take care not to allow the oil level to lower below the specified level of the oil level gauge.
- (3) When bleeding an air from the hydraulic circuit, keep the motor speed at 1000 rpm or less. Operate each actuator for three or more cycles and carry out idling for 5 minutes or more.

8. MAINTENANCE

The maintenance of this hydraulic pump is limited mainly to the tank, in particular, the hydraulic oil change.

Since the maintenance interval varies depending on respective operation and use conditions, the cautions described below for the users should be for reference only.

(1) Checking the filter

- ① Every day for the initial period after start up.
- ② Once a week when the operation becomes stable.
- ③ Once a month when the operation hours exceed about 100 hours.

※ When any part of the hydraulic system is changed (e.g., assembling of an additional part, change and repair of the piping), check the filter newly as in the case of startup.

(2) Changing the filter

- ① After startup
- ② After 500 hours of operation
- ③ Every 500 hours of operation after that, and each time the hydraulic oil is changed or the failure occurs. If any abnormal fouling of the filter is observed during daily check up to the first filter change after startup, find out the cause.

In this case, do not extend the check and filter change intervals to 500 hours.

※ The paper filter can not be cleaned. Change the filter as a whole.

(3) Changing the hydraulic oil

- ① After 2000 hours of operation.
- ② Every 2000 hours of operation or once a year after that.

The change interval may have to be shortened depending on the degree of fouling and the thermal load condition of the hydraulic oil.

If the hydraulic oil is not appropriate and need be changed, pay attention to the following points :

Be sure to control the oil temperature below the highest temperature and above the lowest temperature during operation in winter and summer.

Pay attention to the following points during change of the hydraulic oil :

- Change the hydraulic oil as a whole quantity.
- Do not allow dust to mix into the circuit.
- Clean the tank inside.
- Supply the oil through the filter.

(4) Checking for the oil leakage

- ① Daily during the initial period after startup.
- ② Once a week when the operation becomes stable.

(5) Checking the temperature

- ① Monitor the temperature continuously.
- ② When the viscosity is above the allowable value because of low hydraulic oil temperature, warm-up operation is necessary.

Start the motor with the speed set to about one half of the rated speed, then operate the actuator under the load for a short period.

When the oil temperature is below the allowable ambient temperature, it is necessary to preheat the oil tank before start of the motor.

Take care not to allow the hydraulic oil temperature to exceed +90° C

GROUP 2 MAIN CONTROL VALVE

1. STRUCTURE

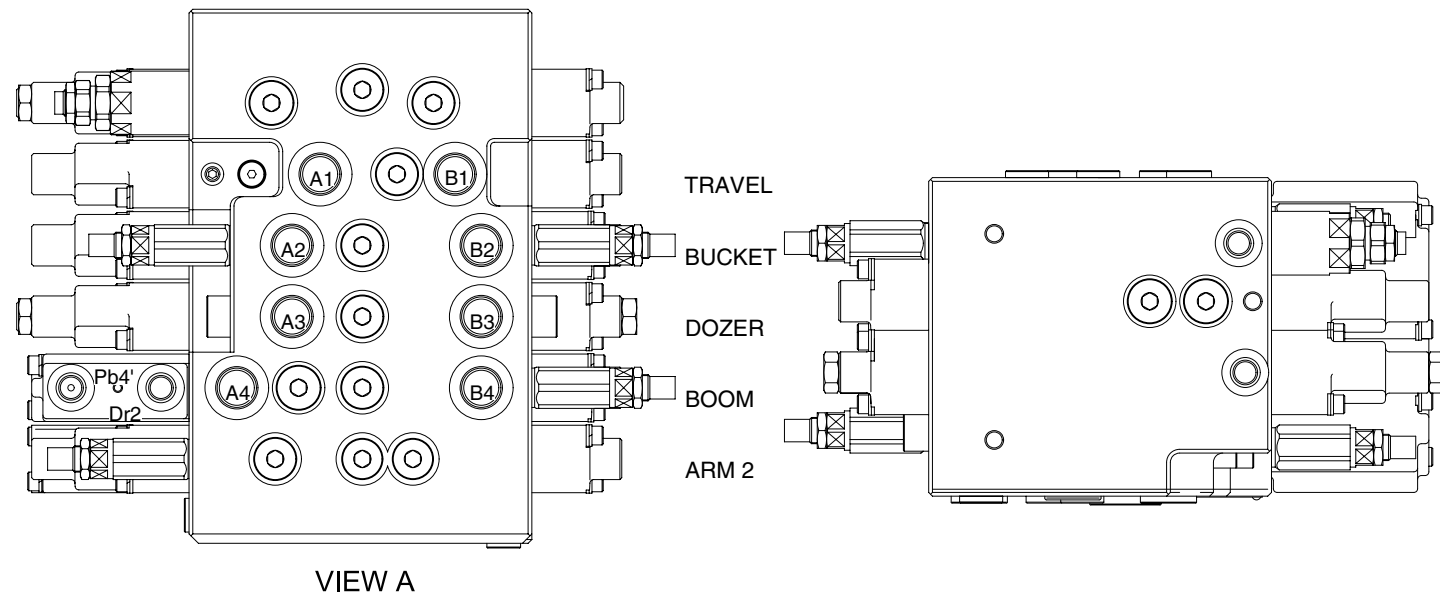

VIEW A

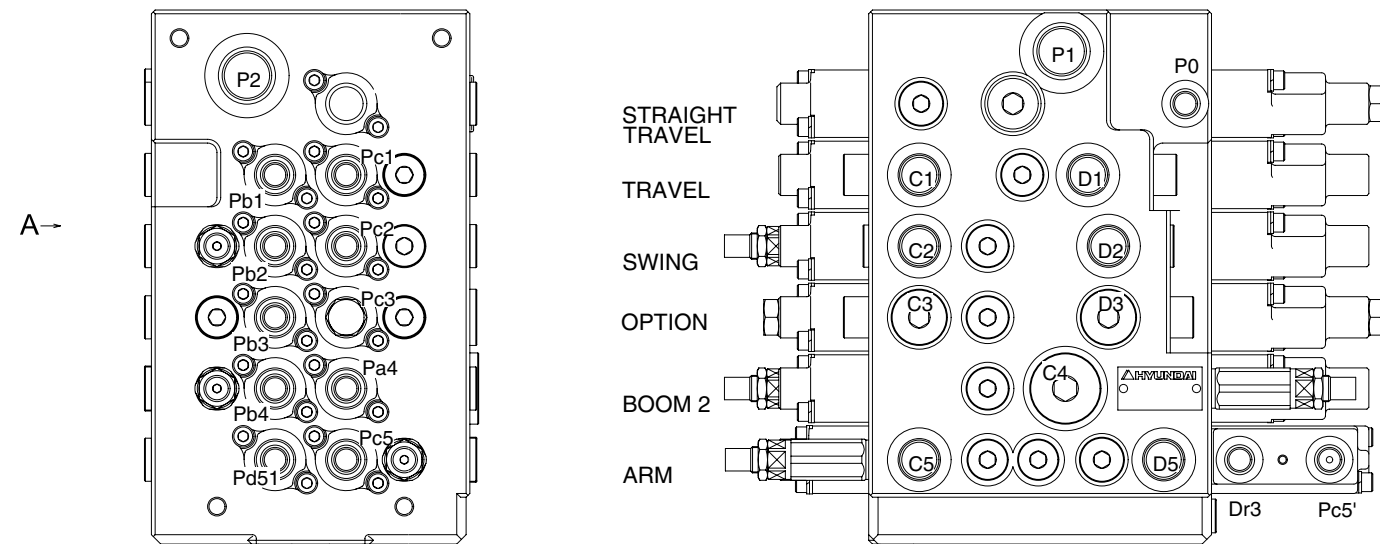

A→

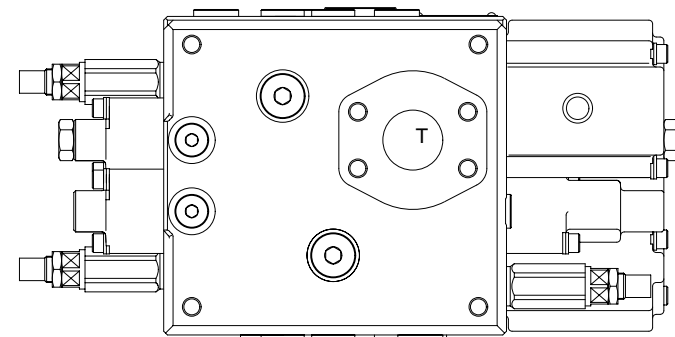

Mark	Port name	Port size	Tightening torque
Rs	Make up for swing motor	G1/4	2.5~3kgf · m (18.1~21.7lbf · ft)
Pa1	Travel left pilot port(FW)		
Pb1	Travel left pilot port(BW)		
Pc1	Travel right pilot port(BW)		
Pd1	Travel right pilot port(FW)		
Pa2	Bucket in pilot port		
Pb2	Bucket out pilot port		
Pc2	Swing pilot port(RH)		
Pd2	Swing pilot port(LH)		
Pc3	Option pilot port		
Pd3	Option pilot port		
Pa40	Boom up pilot port		
Pa41	Boom up confluence pilot port		
Pb4	Boom down pilot port		
Pb4'	Lock valve pilot port(Boom)		
Pc50	Arm in pilot port		
Pc51	Arm in confluence pilot port		
Pc5'	Lock valve pilot port(Arm)		
Pd50	Arm out pilot port		
Pd51	Arm out confluence pilot port		
PO	Pilot pressure port		
Dr1	Drain port		
Dr2	Drain port		
Dr3	Drain port		
A1	Travel motor right side port(FW)		
B1	Travel motor right side port(BW)		
C1	Travel motor left side port(BW)		
D1	Travel motor left side port(FW)		
A2	Bucket head side port		
B2	Option port		
C2	Swing motor port(LH)		
D2	Swing motor port(RH)		
A3	Dozer up port		
B3	Dozer down port		
C3	Bucket rod side port		
D3	Option port		
A4	Boom head side port		
B4	Boom rod side port		
C5	Arm head side port		
D5	Arm rod side port		
P1	Pump port(P1 side)	G3/4	8~9kgf · m (57.9~65.1lbf · ft)
P2	Pump port(P2 side)		
T1	Return port	SAE3000, 1 1/4 (M10)	5.5~8.3kgf · m (39.8~60.0lbf · ft)

7072MCV30

1) Structure(1/4)

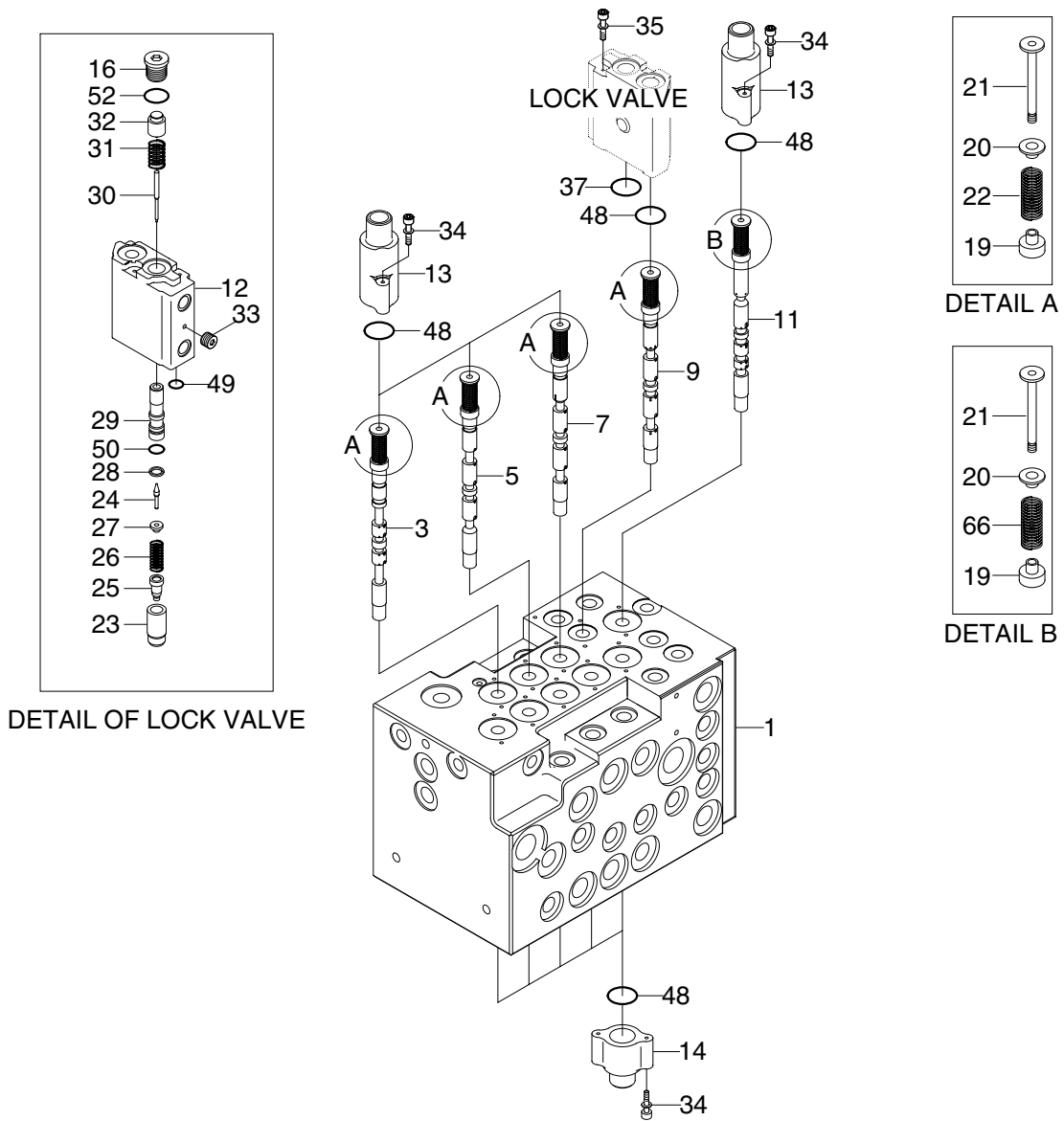

- | | | | | | |
|----|------------------|----|-----------------------|----|-------------------|
| 1 | Body | 20 | Spring holder | 31 | Lock valve spring |
| 3 | Spool-Travel(LH) | 21 | Spool end | 32 | Piston |
| 5 | Spool-Swing | 22 | Spring | 33 | Plug |
| 7 | Spool-Option | 23 | Lock valve | 34 | Socket head bolt |
| 9 | Spool-Boom 2 | 24 | Poppet | 35 | Socket head bolt |
| 11 | Spool-Arm | 25 | Lock valve restrictor | 37 | O-ring |
| 12 | Pilot-Cover | 26 | Lock valve spring | 48 | O-ring |
| 13 | Pilot-Cover | 27 | Spring holder | 49 | O-ring |
| 14 | Pilot-Cover | 28 | Retaining ring | 50 | O-ring |
| 16 | Plug | 29 | Piston guide | 52 | O-ring |
| 19 | Spring holder | 30 | Piston | 66 | Spring |

7072MCV31

2) Structure(2/4)

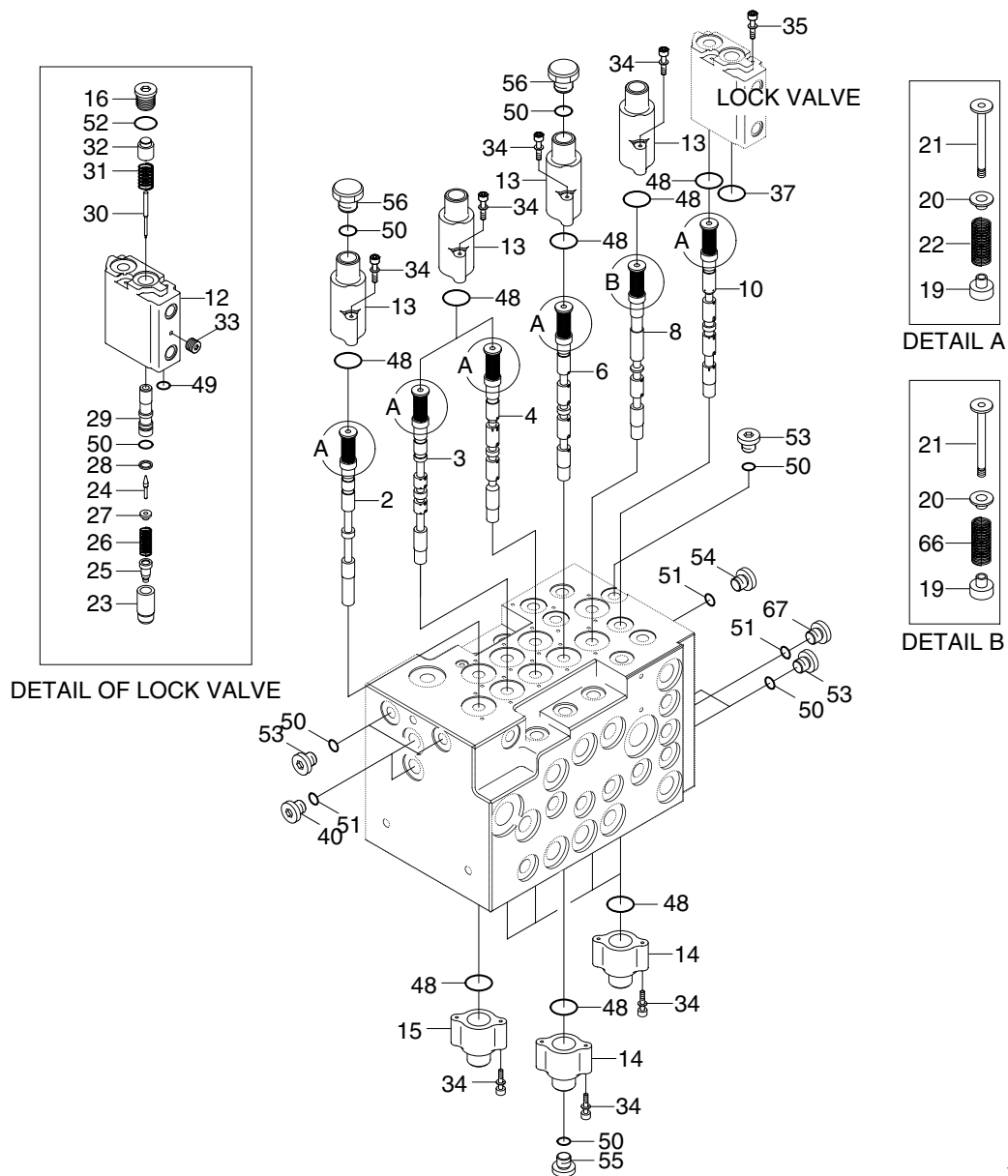

- | | | | | | |
|----|-----------------------|----|-----------------------|----|-----------------|
| 2 | Spool-Travel straight | 23 | Lock valve | 40 | Plug |
| 4 | Spool-Travel(RH) | 24 | Poppet | 48 | O-ring |
| 6 | Spool-Dozer | 25 | Lock valve restrictor | 49 | O-ring |
| 8 | Spool-Boom | 26 | Lock valve spring | 50 | O-ring |
| 10 | Spool-Arm 2 | 27 | Spring holder | 51 | O-ring |
| 12 | Pilot-Cover | 28 | Retaining ring | 52 | O-ring |
| 13 | Pilot-Cover | 29 | Piston guide | 53 | Plug |
| 14 | Pilot-Cover | 30 | Piston | 54 | Restrictor plug |
| 15 | Pilot-Cover | 31 | Lock valve spring | 55 | Plug |
| 16 | Plug | 32 | Piston | 56 | Plug |
| 19 | Spring holder | 33 | Plug | 66 | Spring |
| 20 | Spring holder | 34 | Socket head bolt | 67 | Restrictor plug |
| 21 | Spool end | 35 | Socket head bolt | | |
| 22 | Spring | 37 | O-ring | | |

3) Structure(3/4)

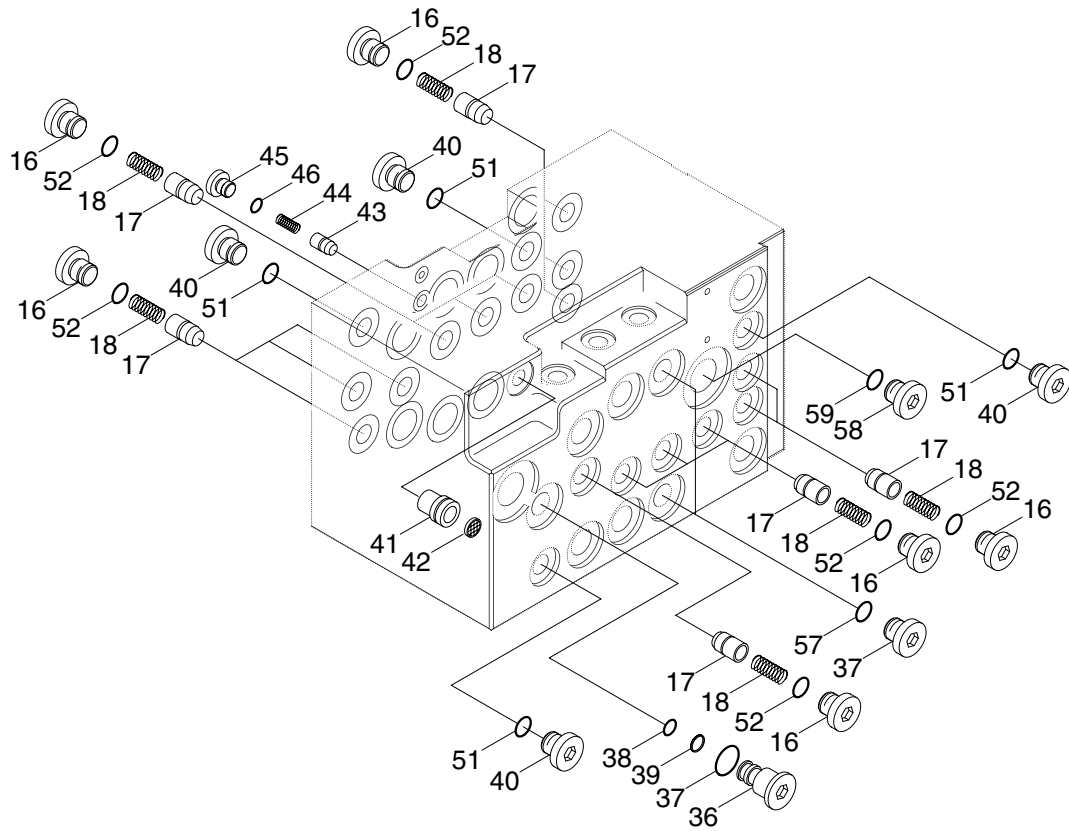

7072MCV33

- | | | | | | |
|----|--------------------|----|--------------------|----|--------|
| 16 | Plug | 40 | Plug | 51 | O-ring |
| 17 | Check valve | 41 | Restrictor plug | 52 | O-ring |
| 18 | Check valve spring | 42 | Coin type filter | 57 | Plug |
| 36 | Plug | 43 | Check valve | 58 | Plug |
| 37 | O-ring | 44 | Check valve spring | 59 | O-ring |
| 38 | O-ring | 45 | Plug | | |
| 39 | Back up ring | 46 | O-ring | | |

4) Structure(4/4)

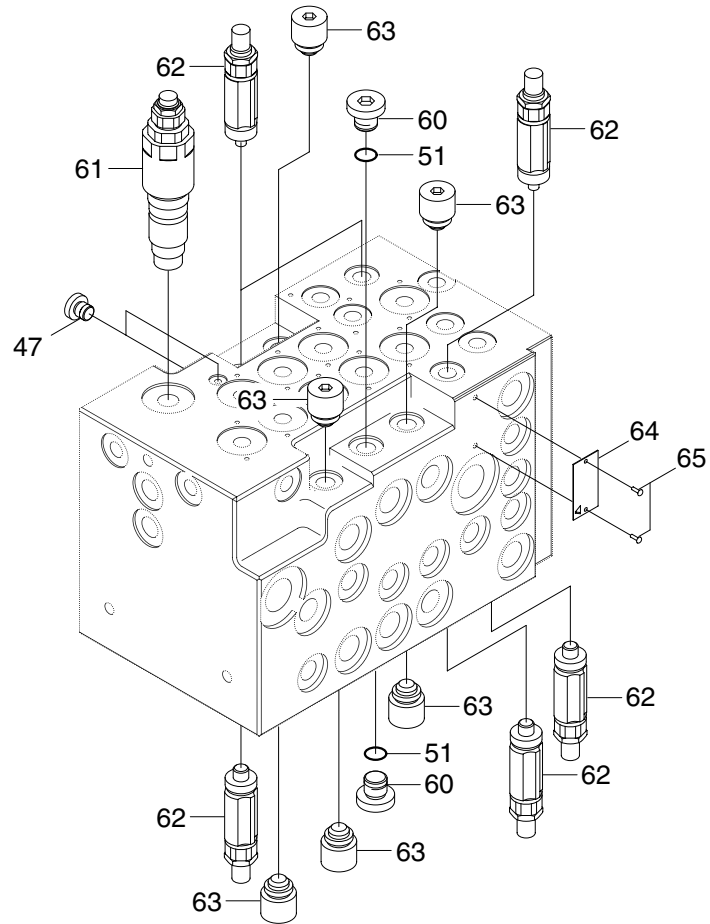

7072MCV34

- | | | | |
|----|-------------------|----|-----------------------|
| 47 | Plug | 62 | Overload relief valve |
| 48 | O-ring | 63 | Relief valve plug |
| 51 | O-ring | 64 | Name plate |
| 60 | Plug | 65 | Pin |
| 61 | Main relief valve | | |

2. HYDRAULIC CIRCUIT DIAGRAM

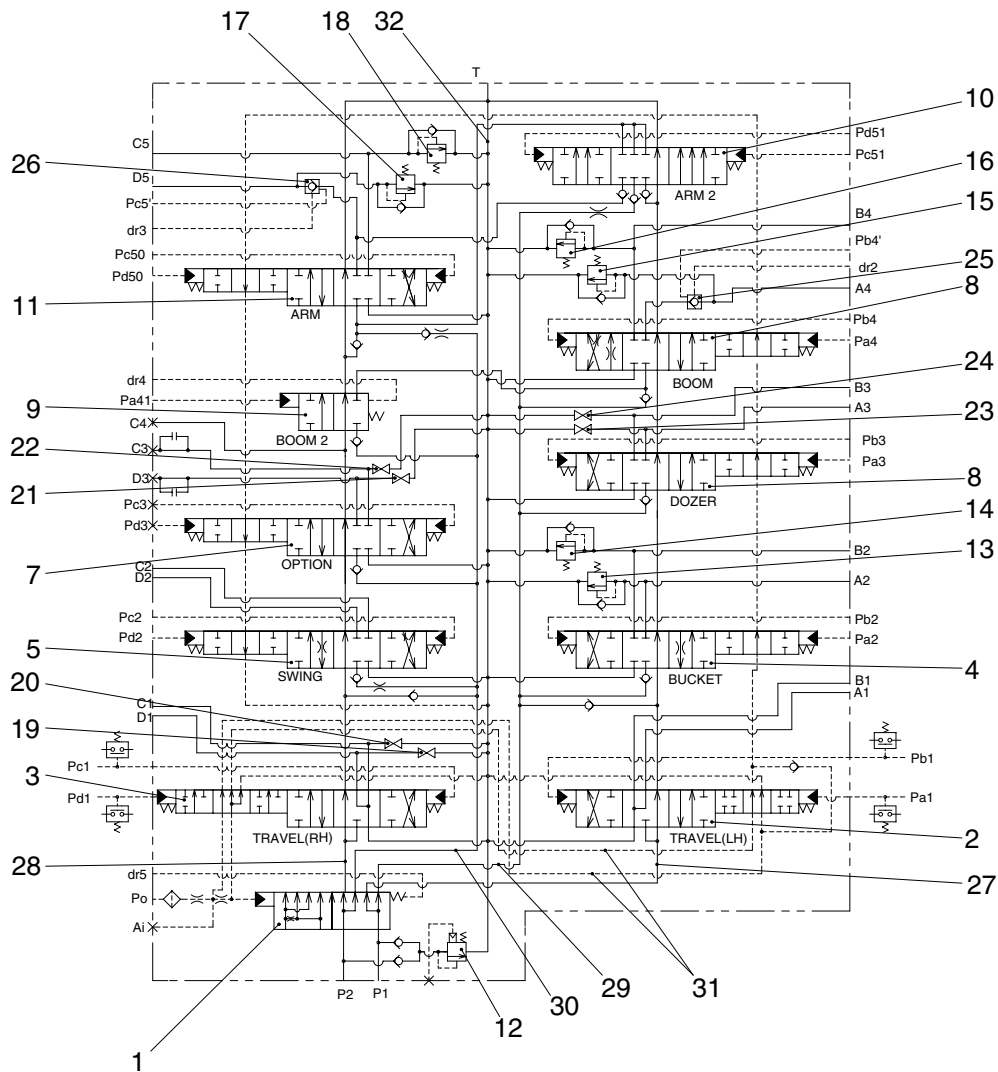

RD8072MVC01

Ref. No.	Description	Ref. No.	Description
1	Spool - Straight travel	17	Overload relief valve
2	Spool - Tavel left	18	Overload relief valve
3	Spool - Tavel right	19	Relief plug
4	Spool - Bucket	20	Relief plug
5	Spool - Swing	21	Relief plug
6	Spool - Dozer	22	Relief plug
7	Spool - Option	23	Relief plug
8	Spool - Boom	24	Relief plug
9	Spool - Boom2	25	Boom lock valve
10	Spool - Arm2	26	Arm lock valve
11	Spool - Arm	27	By - Pass(P1)
12	Main relief valve	28	By - Pass(P2)
13	Overload relief valve	29	Parallel passage(P1)
14	Overload relief valve	30	Parallel passage(P2)
15	Overload relief valve	31	Pilot signal passage
16	Overload relief valve	32	Tank passage

3. FUNCTION

1) CONTROL VALVE

(1) Neutral

P1 : The oil from the pump flows into the control valve through the port P1, P1 and also into the left travel spool portion via the travel straight spool land.

As by-pass(P1) is not closed by the spool at the spool in neutral, the oil go through the by-pass of each spool of left travel → bucket → dozer → boom → arm2, and flows out the tank passage through the passage of the discharge portion body.

P2 : The oil from the pump flows into the control valve through the port P2, P2 and also into the right travel spool portion via the travel straight spool land.

As by-pass(P2) is not closed by the spool at the spool in neutral, the oil go through the by-pass of each spool of right travel → swing → option → boom2 → arm, and flows out the tank passage through the passage of the discharge portion body.

P0 : The oil from the pump flows into the control valve through the port P0, and further into the pilot signal passage via the filter and orifice in the supply portion.

At the spool neutral, it flows from travel spool(LH/RH) portion to the tank passage through the passage in the travel spool(LH/RH).

Accordingly, the pilot signal passage pressure comes to be equal to the tank pressure, and the also the receiving pressure on the travel straight spool stays to be unswitched.

At neutral(P1)

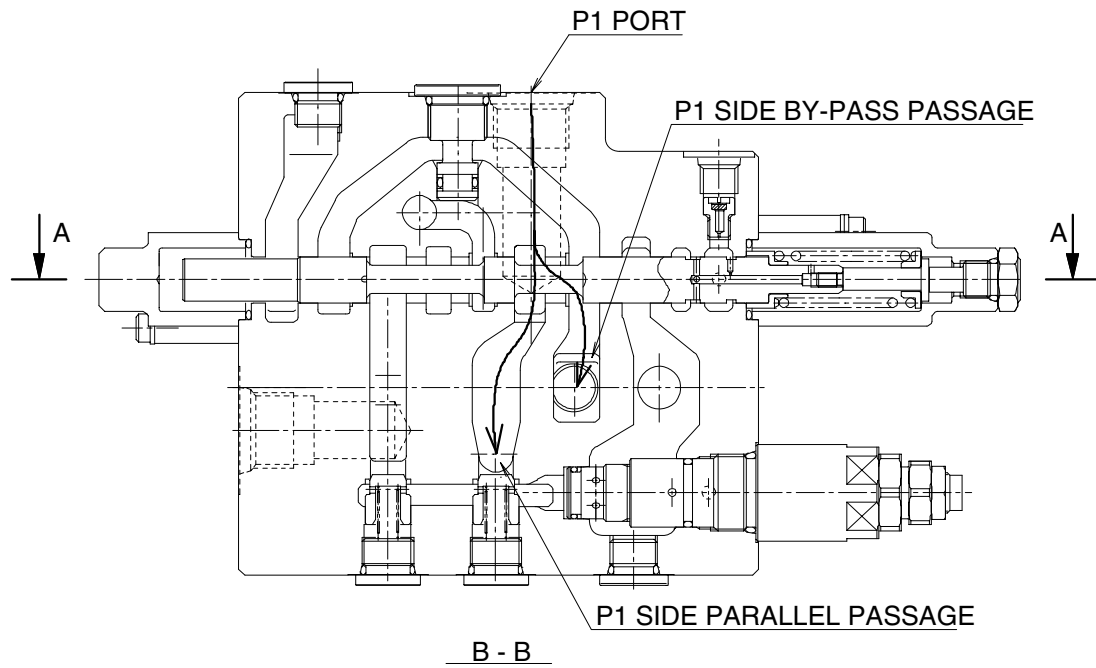

7072MCV02

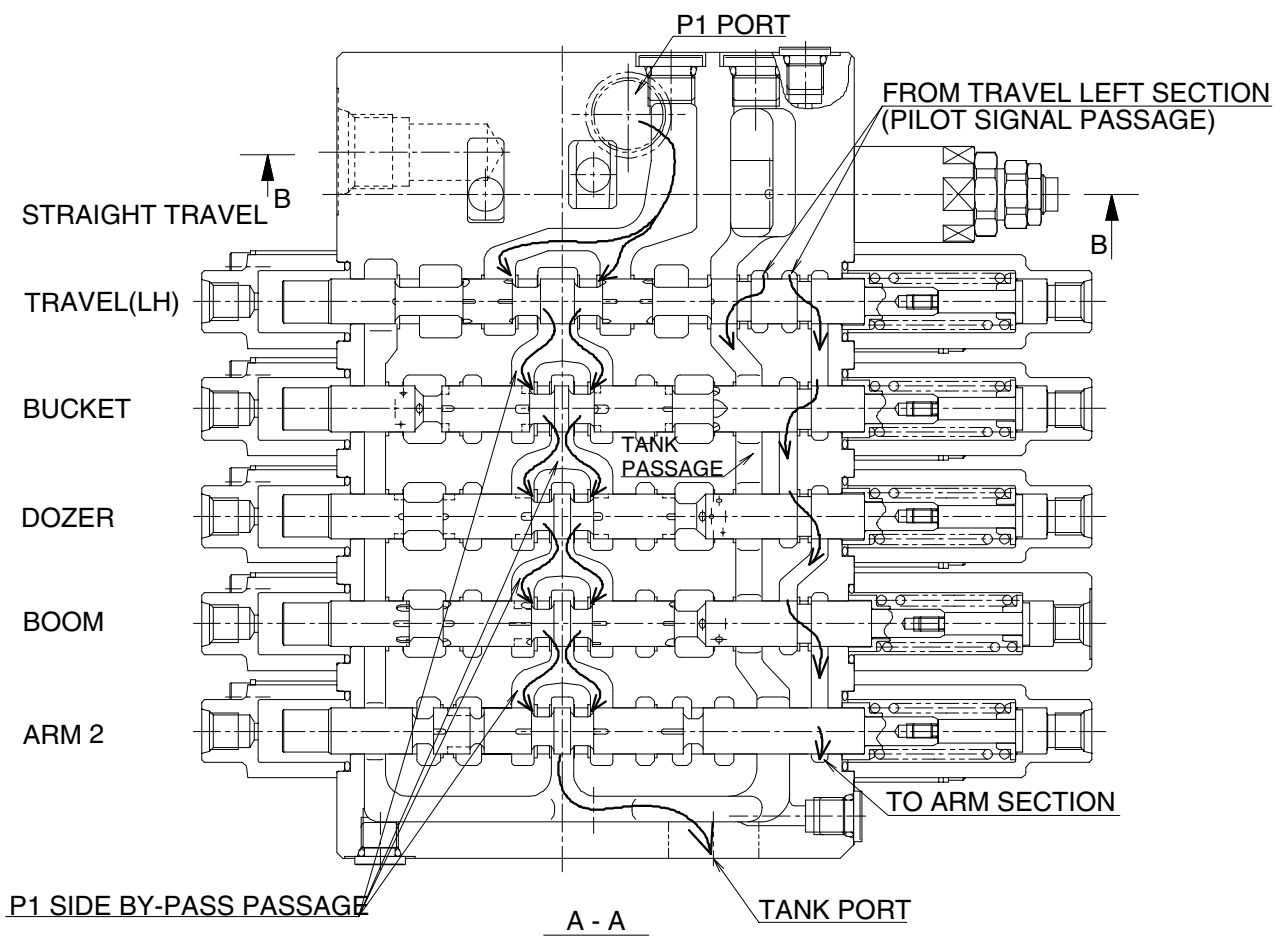

7072MCV03

At neutral(P2)

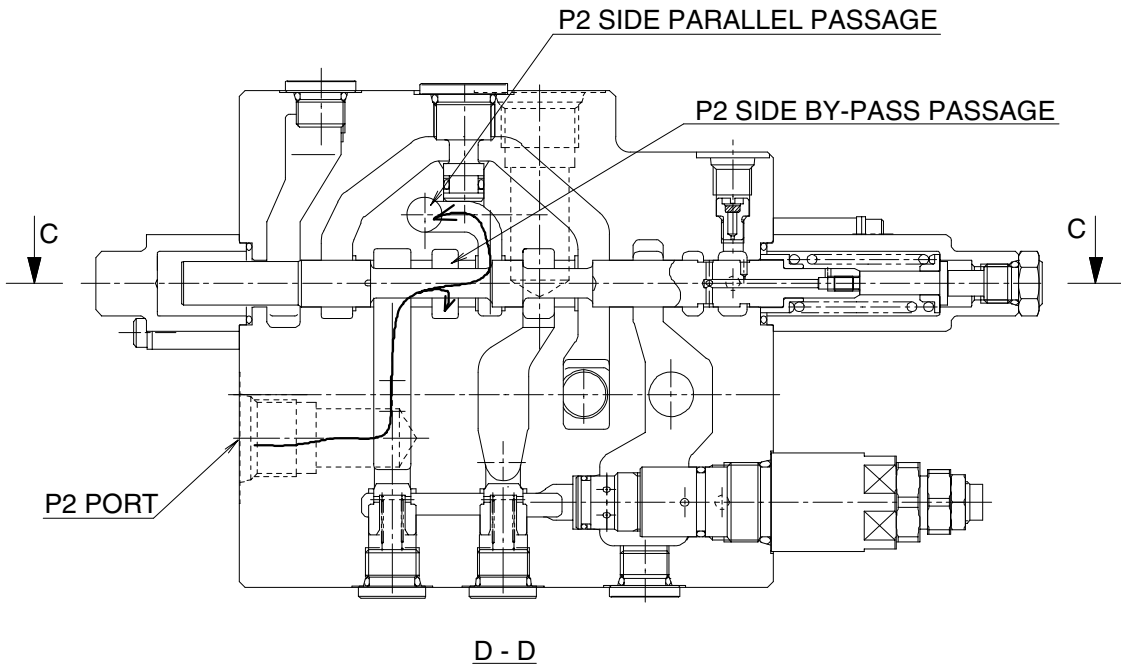

7072MCV04

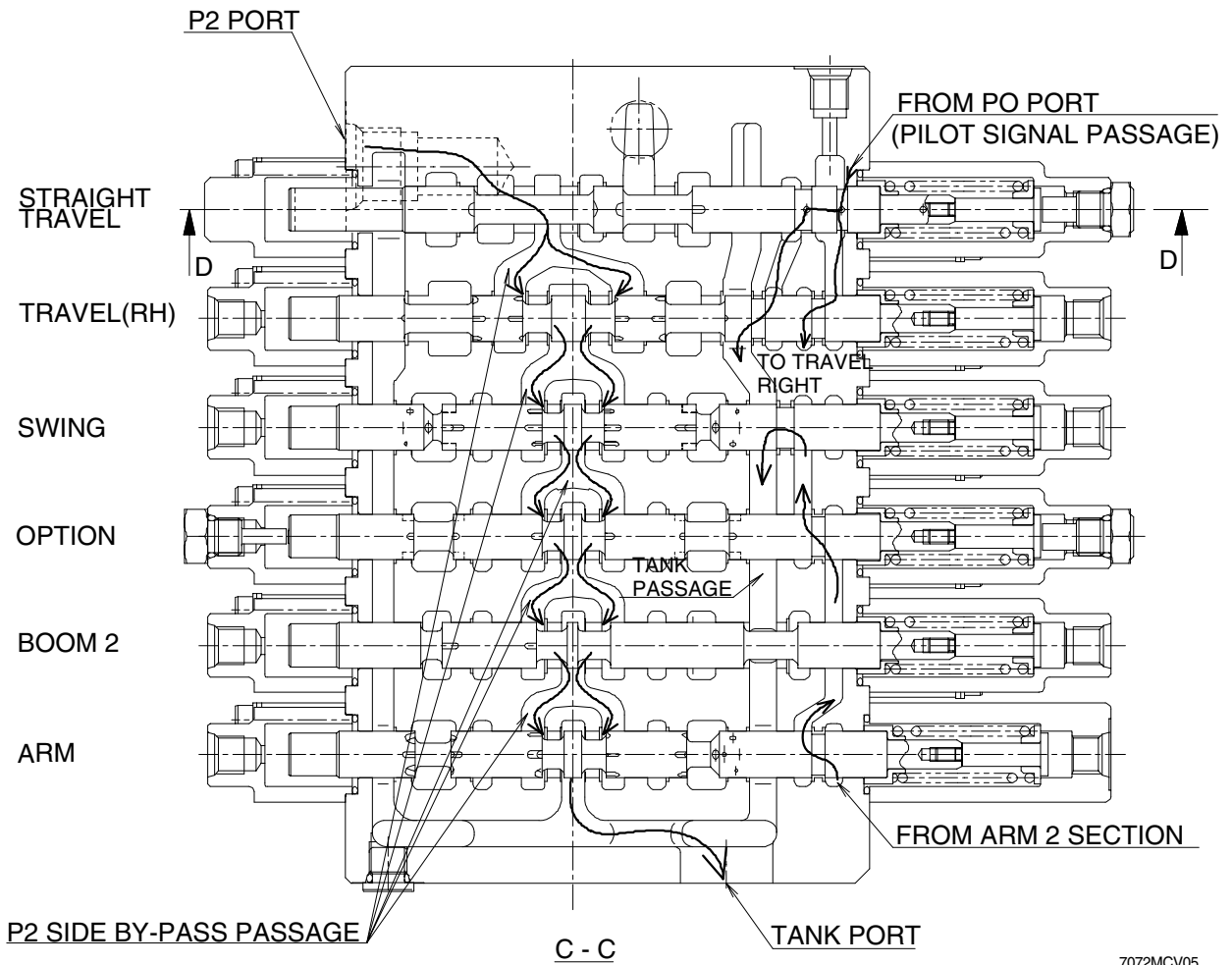

7072MCV05

(2) Operating of each section

Here, it represents and the operation of the boom(raise) and arm(dump & crowd) section is explained.

① Boom raise operation

With the boom raise operation, the pilot secondary pressure enters into the Pa40 port, and moves the spool for the boom operation. And with the movement of the spool, as the by-pass circuit is cut at the boom switching section, the oil is received through the P1 port flows into the parallel circuit on the boom switching section.

With the movement of the spool, as the circuit from the passage leading to the boom lock valve section to the bridge passage is opened, the oil entered in the parallel circuit passes through the load check valve on the boom switching section and flows into the A4 port through the bridge passage and open the boom lock valve(free flow) and is fed into the boom cylinder head side.

Moreover, secondary pilot pressure enters into Pa41 port of boom2 spool simultaneously, and moves boom2 spool. And with the movement of the boom2 spool, as the by-pass(P2) circuit is cut at the boom2 switching section, the oil received through the P2 port flows into the P2 parallel circuit on the boom2 switching section. The oil which flowed into P2 parallel passage in the boom2 parallel circuit on the boom2 switching section. The oil which flowed into P2 parallel passage in the boom2 section flows into the bridge passage of the boom section from the land of boom2 spool released by shift of boom2 spool. And P2 oil is fed into the boom cylinder head side.

On the other hand, the return oil from the boom cylinder rod side flows into the B4 port, and with the movement of the spool the oil flows out into the tank passage.

The oil from the port P0 flows to the pilot signal passage through the orifice.

So the oil in the pilot signal passage flows from the travel section to the tank passage, the pilot signal pressure becomes to equal to the tank pressure, therefore the travel straight spool is not switched.

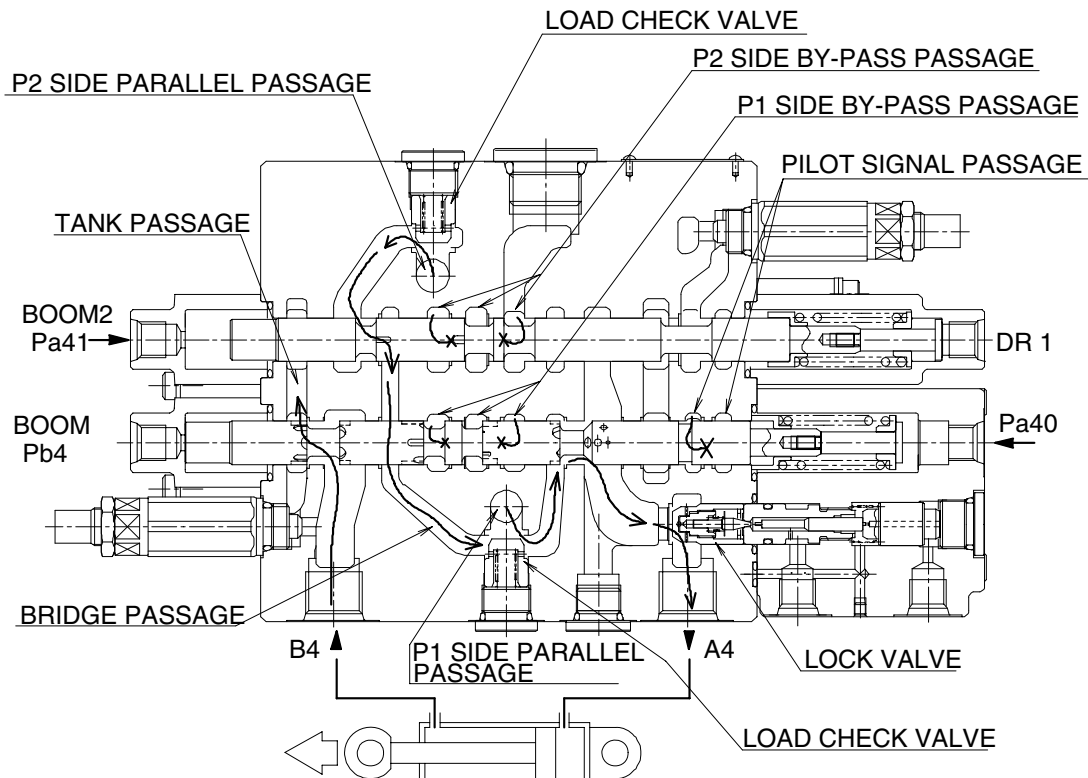

7072MCV06

② Arm crowd operation

With the arm crowd operation, the pilot secondary pressure enters into the Pc50 port, and moves the spool for the arm operation. And with the movement of the spool, as the by-pass circuit is cut at the arm switching section, the oil received through the P2 port flows into the parallel circuit on the arm switching section.

With the movement of the spool, as the circuit from the passage leading to the bridge passage is opened, the oil entered in the parallel circuit passes through the load check valve on the arm switching section and flows into the D5 port through the bridge passage and is fed into the arm cylinder rod side.

Moreover, secondary pilot pressure enters into Pc51 port of arm2 spool simultaneously, and moves arm2 spool. And with the movement of the arm2 spool, as the by-pass(P1) circuit is cut at the arm2 switching section, the oil received through the P1 port flows into the arm confluence passage through the check valve in the arm2 switching section. The oil which flowed into arm confluence passage in the arm2 section flows into the bridge passage of the arm section from the land of arm2 spool released by shift of arm2 spool. And P1 oil is fed into the arm cylinder head side.

On the other hand, secondary pilot pressure enters into Pc5', port of arm lock valve simultaneously, so arm lock valve is released. (Refer to "ACTUATION OF LOCK VALVE, RELEASING" page(2-23)). And the return oil from the arm cylinder rod side flows into the D5 port, and with the movement of the spool some of the oil flows out into the tank passage through the meter-out orifice of the arm spool.

The rest of the oil flows to the bridge passage through the regenerating check valve, regenerating land of the arm2 spool and into the port C5. Accordingly, in this case, the arm cylinder extends the rod to start crowding, and further, the supply flow to the arm cylinder increased by the regeneration by which the cylinder moves faster.

The oil from the port P0 flows to the pilot signal passage through the orifice.

So the oil in the pilot signal passage flows from the travel section to the tank passage, the pilot signal pressure becomes to equal to the tank pressure, therefore the travel straight spool is not switched.

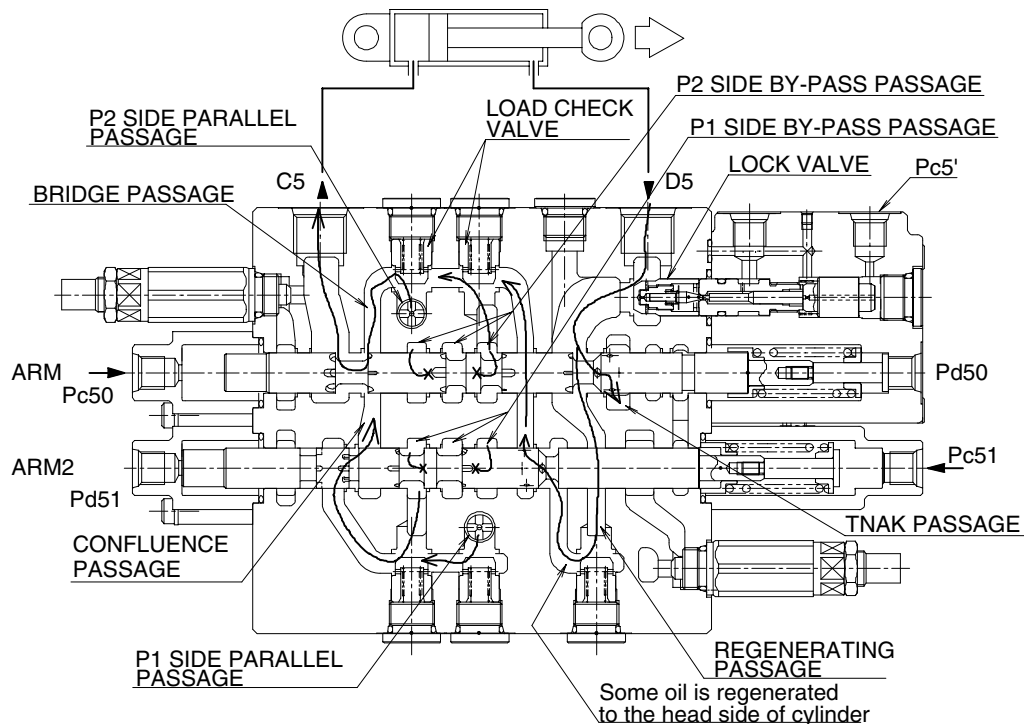

7072MCOV07

③ Arm dump operation

With the arm dump operation, the pilot secondary pressure enters into the Pd50 port, and moves the spool for the arm operation. And with the movement of the spool, as the by-pass circuit is cut at the arm switching section, the oil received through the P2 port flows into the parallel circuit on the arm switching section.

With the movement of the spool, as the circuit from the passage leading to the arm lock valve section to the bridge passage is opened, the oil entered in the parallel circuit passes through the load check valve on the arm switching section and flows into the C5 port through the bridge passage and open the arm lock valve (free flow) and is fed into the arm cylinder rod side.

Moreover, secondary pilot pressure enters into Pd51 port of arm2 spool simultaneously, and moves arm2 spool. And with the movement of the arm2 spool, as the by-pass (P1) circuit is cut at the arm2 switching section, the oil received through the P1 port flows into the arm confluence passage through the check valve in the arm2 switching section. The oil which flowed into arm confluence passage in the arm2 section flows into the bridge passage of the arm section from the land of arm2 spool released by shift of arm2 spool. And P1 oil is fed into the arm cylinder rod side.

On the other hand, the return oil from the arm cylinder head side flows into the C5 port, and with the movement of the spool the oil flows out into the tank passage.

The oil from the port P0 flows to the pilot signal passage through the orifice.

So the oil in the pilot signal passage flows from the travel section to the tank passage, the pilot signal pressure becomes to equal to the tank pressure, therefore the travel straight spool is not switched.

Also about other switching sections (travel, swing, bucket, etc.), there is only no spool like a boom2 or an arm2, and an operation is the same.

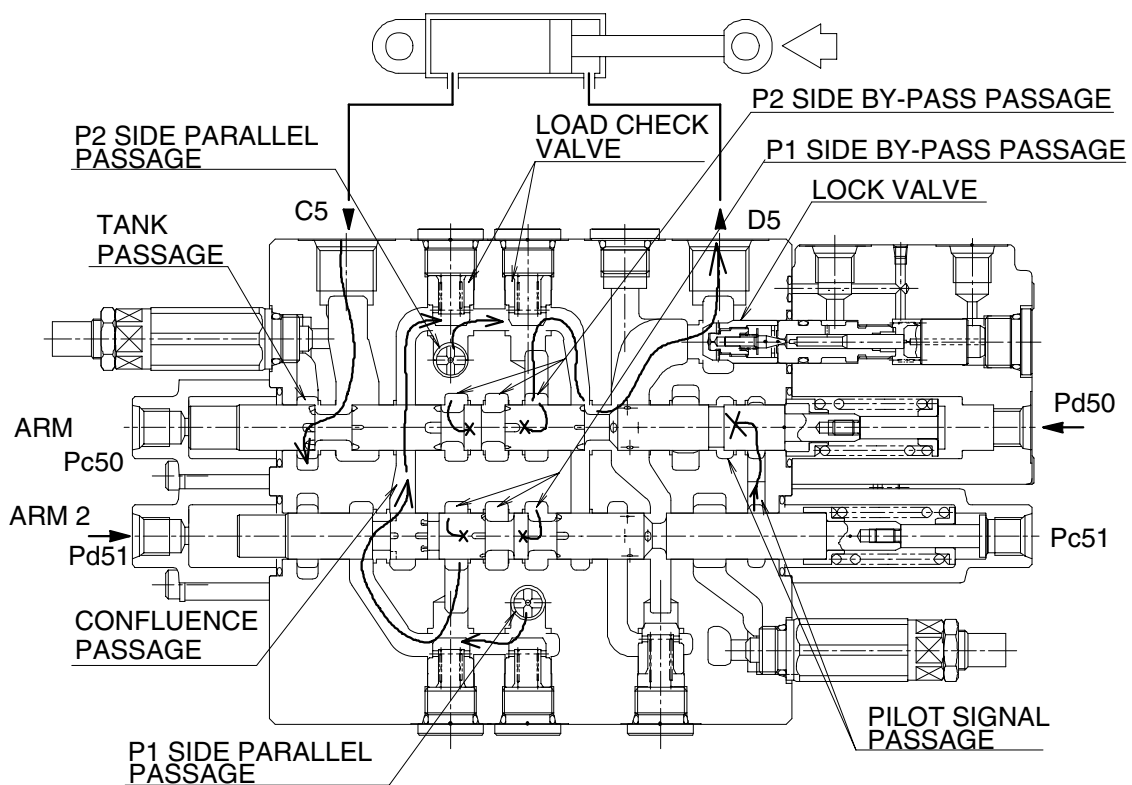

7072MCV08

(3) Travel straight function

Straight-travel valve is the valve for keeping traveling straight, when boom, arm, bucket, swing, dozer, or option is operated at the time of traveling.

When any of the both travels and arm, boom, bucket, swing, dozer, or option is switched at the state of the pilot pressure supplied in the port P0, the pilot signal passage is closed from the tank passage, and the pilot pressure comes to act in the pilot passage.

Therefore, the pilot pressure acts in the spring room of the straight travel spool, and the spool against the spring moves until to contact to the pilot cover of the opposite side.

When the straight travel spool is switched, the oil pressure from P1 is led to the each attachment switching section through the P1 and P2 parallel passage.

On the other hand, the oil from P2 is supplied to the both travel section through P1 and P2 bypass passage.

Therefore, when attachments(boom or arm...etc.) is switched at the time of both travels, since the oil of P2 mainly flows to both travels, and the oil of P1 mainly flows to attachments, it can keep traveling straight.

The following figure expresses the state when operating the both travels and the swing section as reference.

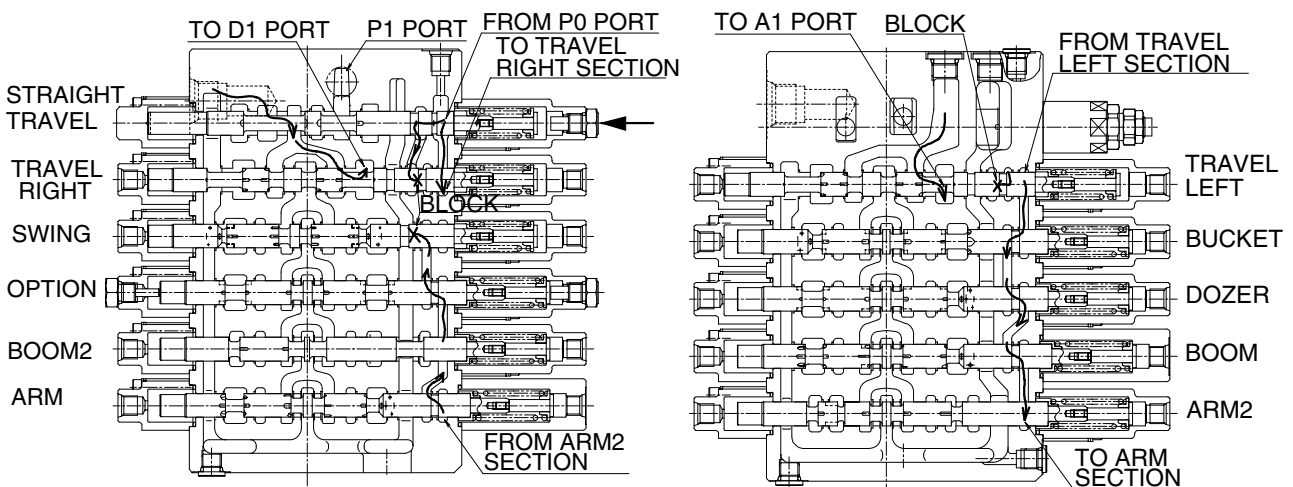
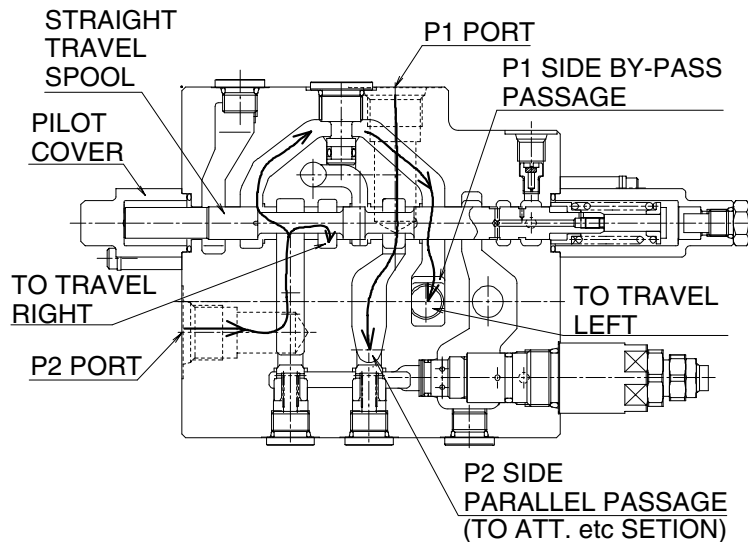

2) ACTUATION OF LOCK VALVE(BOOM AND ARM)

(1) Holding

In the condition where the spool for booms is on the neutral position, pilot piston chamber(A) is connected to the drain passage through pilot port(Pb4') used to release the lock valve, and piston chamber(b) is also connected to the drain passage through drain port(DR2).

Therefore, piston(C) must be held in the condition shown in the figure. Then the retaining pressure of the boom cylinder acts on the lock valve chamber as shown in the figure, and pushes the needle valve against the seat section, preventing the leakage on the boom cylinder head side. Consequently the movement of the boom cylinder due to the leakage is also prevented.

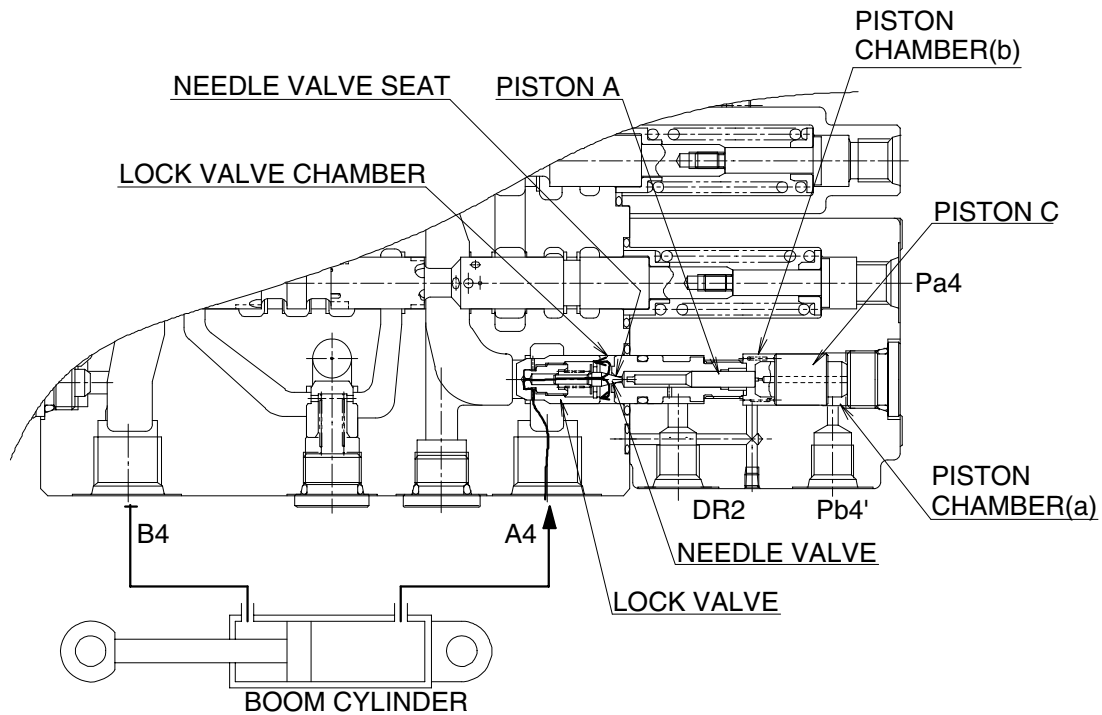

7072MCV10

(2) Releasing

When the pilot pressure acts on pilot port(Pb4') for releasing of lock valve, piston(C) moves leftward, and pushes and opens the needle valve through piston(A).

Then the return oil from the boom cylinder flows through the orifice of the lock valve, lock valve chamber and drilled hole, and flows into the tank passage through the notch of the spool for boom.

The pressure of the lock valve chamber lowers because the needle valve opens and the return oil from the boom cylinder opens the lock valve. Consequently the return oil from the boom cylinder flows into the tank passage through the notch of the spool for boom.

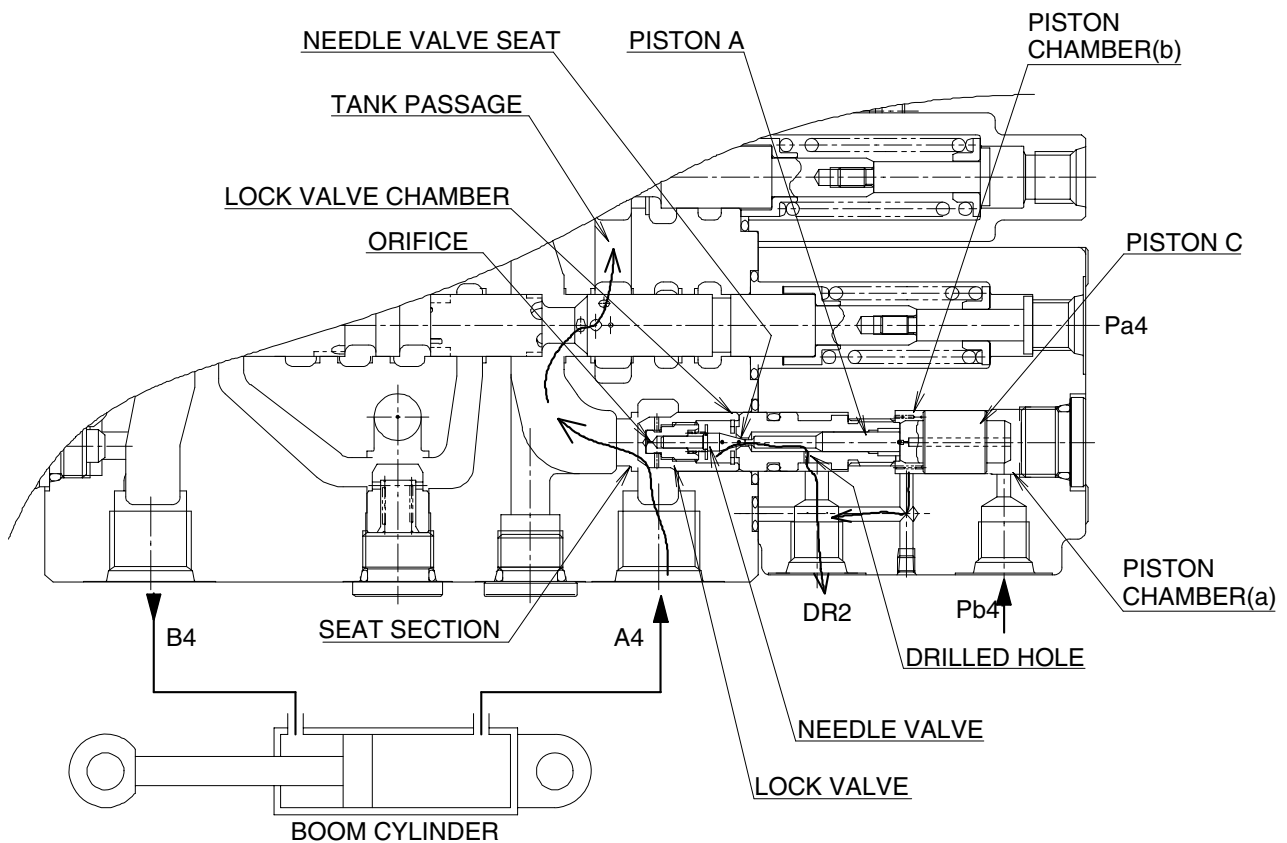

7072MCV11

2) ACTUATION OF RELIEF VALVE

(1) Main relief valve

① Relief function

The pressure passes through the inside of piston placed in the pressure control valve (parent valve) and orifice B and is led to chamber A, while the pressure control valve is seated on the socket also on the body securely.

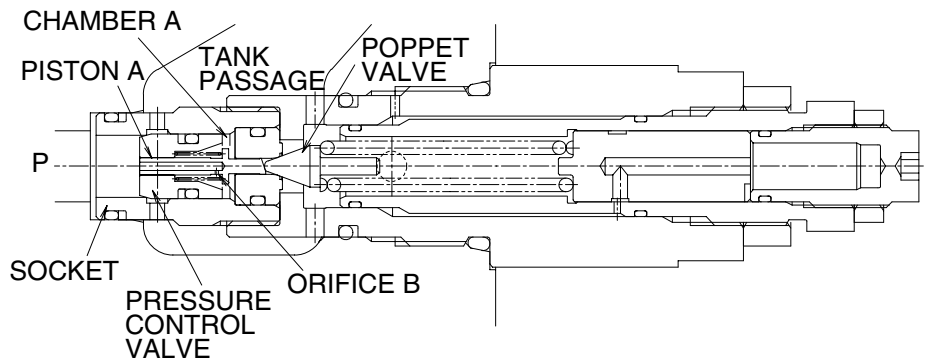

7072MCV12

When the pressure of port P reaches to the set pressure by spring, poppet valve leaves from the seat.

The oil flows through inside of piston A → orifice B → chamber A → circular passage C → drilled hole D and outer side socket, and flows out to the tank passage.

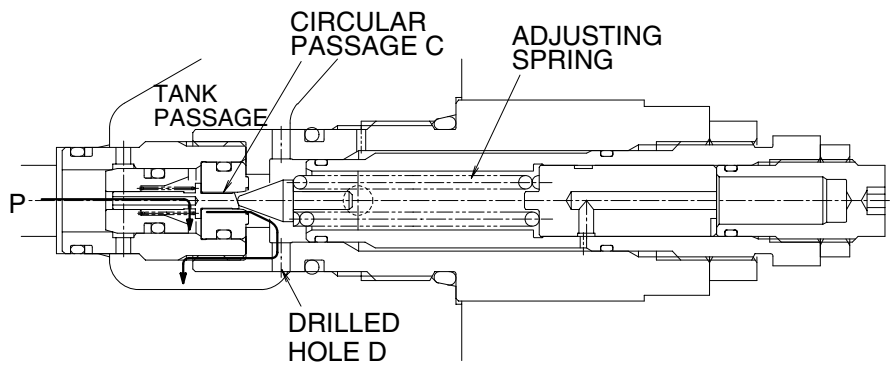

7072MCV13

As the pressure in chamber A drops by unseating of poppet valve, pressure control valve leaves from the seat, by which the oil in port P flows out to the tank passage through drilled hole E.

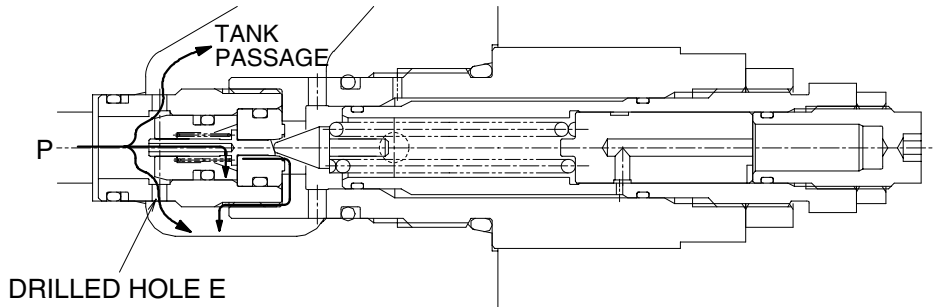

7072MCV14

When the pressure in port P falls to the set pressure by spring, poppet valve is re-seated by the spring, and the pressure in chamber A comes to equal to the port P, by which pressure control valve is re-seated on socket returning to the initial situation.

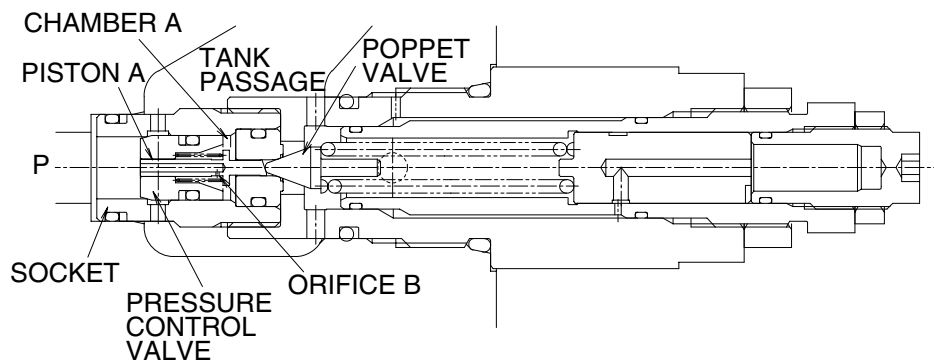

7072MCV12

(2) Overload relief valve

① Relief function

The pressure passes through the inside of piston in the pressure control valve(main valve) and orifice B and is led to chamber A, while the poppet valve is seated on the socket also on the body securely.

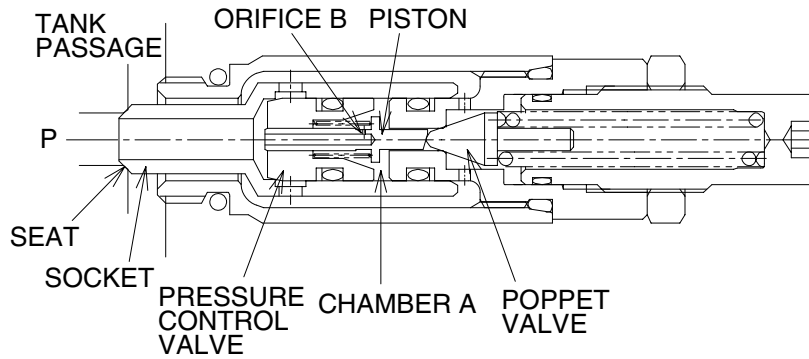

7072MCV16

Then the pressure of port P reaches to the set pressure by spring, poppet valve leaves from the seat.

The oil flows through inside of piston → orifice B → chamber A → circular passage C → drilled hole D and outer side socket, and flows out to the tank passage.

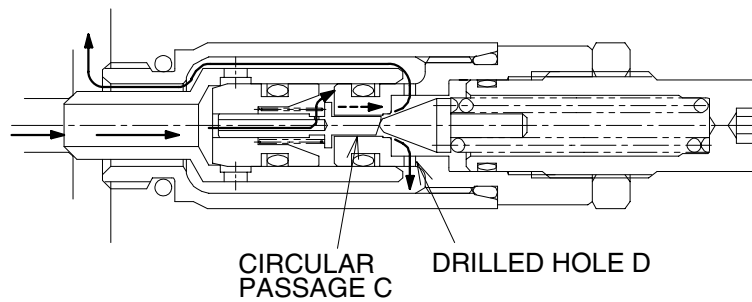

7072MCV17

As the pressure in chamber A drops by unseating of poppet valve, pressure control valve leaves from the seat, by which the oil in port P flows out to the tank passage through drilled hole E.

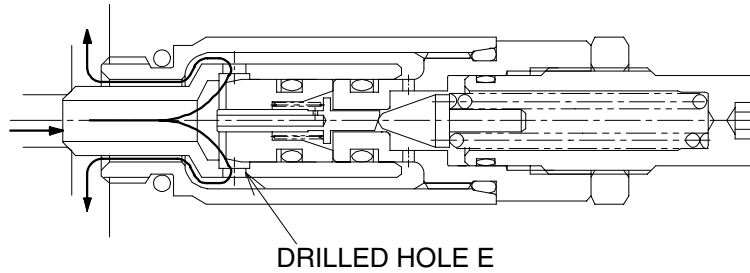

7072MCV18

When the pressure in port P falls to the set pressure by spring, poppet valve is re-seated by the spring, and the pressure in chamber A comes to equal to the port P, by which pressure control valve is re-seated on socket returning to the initial situation.

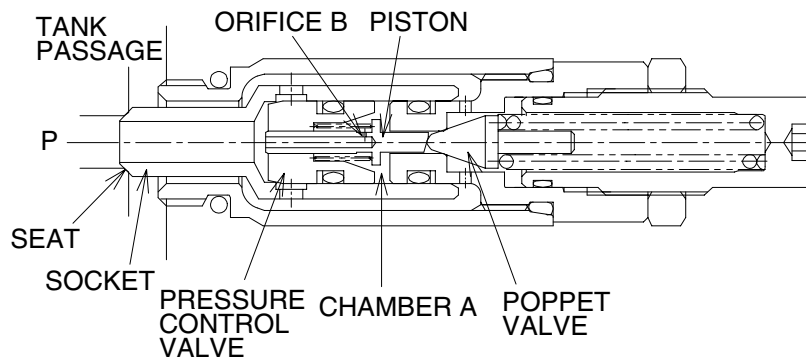

7072MCV16

② Suction function

When the negative pressure is generated in port P, this valve supplies the oil from the tank passage. When the pressure in port P is less than the tank passage pressure, the push-up force acts on socket, by which socket is left from the seat, and the oil flows from the tank passage to port P.

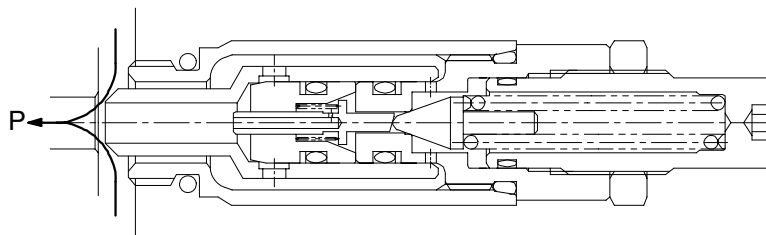

7072MCV19

GROUP 3 SWING DEVICE

1. STRUCTURE

Swing device consists swing motor and swing reduction gear.

1) SWING MOTOR

Swing motor include mechanical parking valve, relief valve, make up valve and time delay valve.

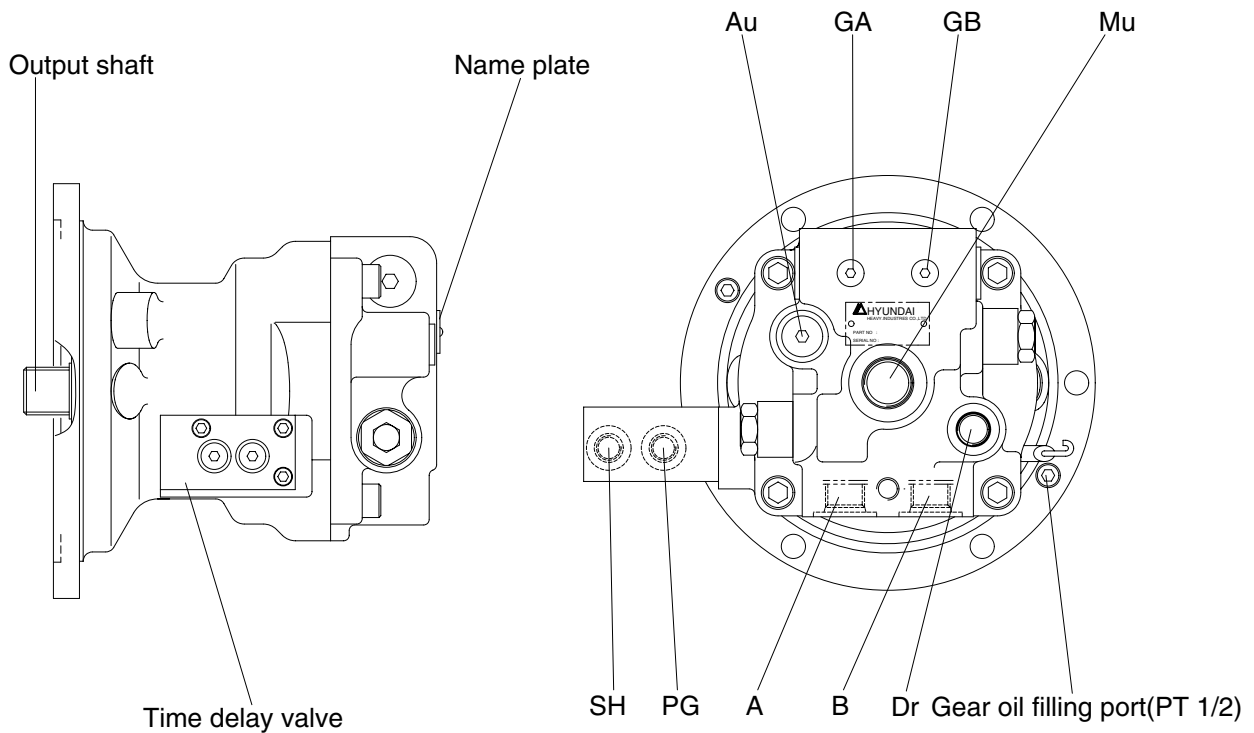

7072SM02

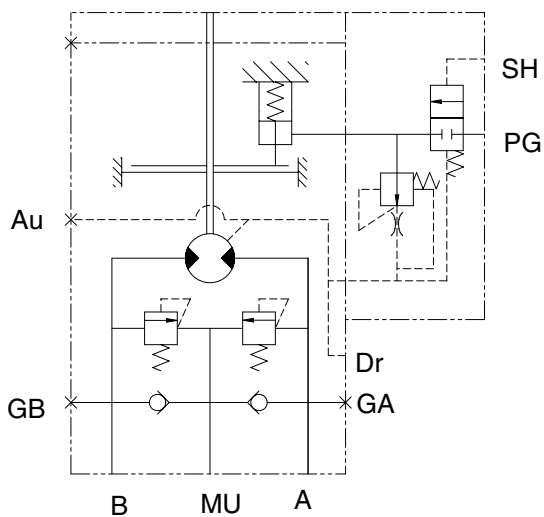

7072SM03

Port	Port name	Port size
A	Main port	PF 1/2
B	Main port	PF 1/2
Dr	Drain port	PF 3/8
Mu	Make up port	PF 3/4
PG	Brake release port	PF 1/4
SH	Brake pilot port	PF 1/4
GA,GB	Gage port	PF 1/4
Au	Air vent port	PF 3/8

(1) Structure of swing motor

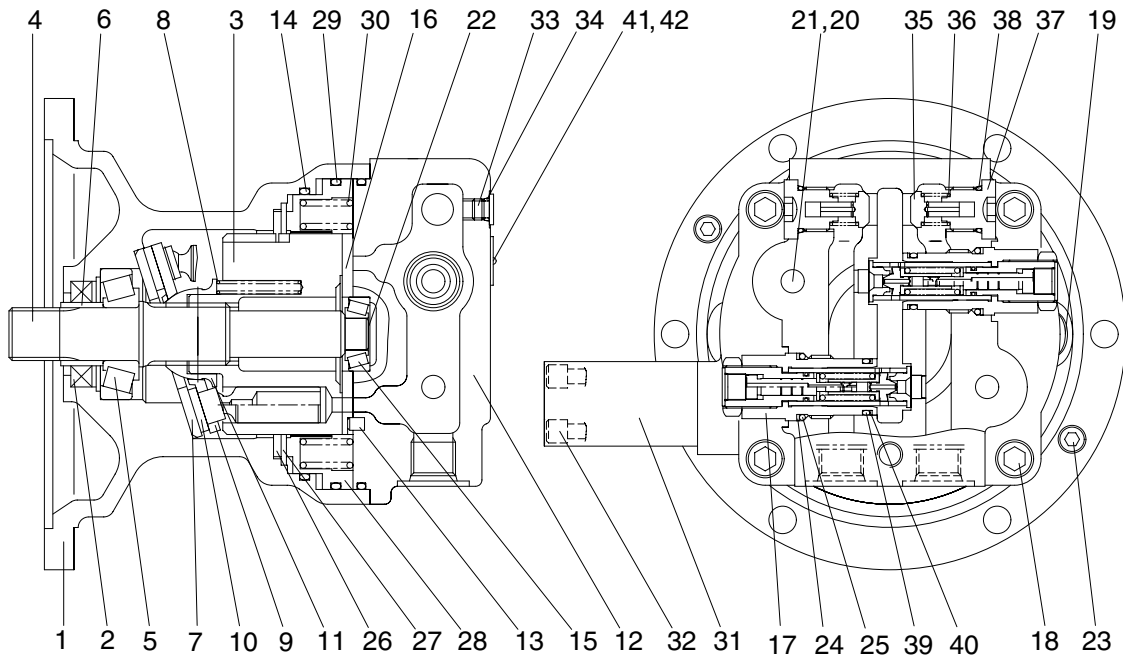

7072SM01

1	Body	15	Taper bearing	29	O-ring
2	Oil seal	16	Valve plate	30	Spring
3	Cylinder block	17	Relief valve assembly	31	Time delay valve
4	Shaft	18	Socket bolt	32	Socket bolt
5	Taper bearing	19	Plug	33	Plug
6	Bushing	20	Plug	34	O-ring
7	Shoe plate	21	O-ring	35	Valve
8	Spring	22	Shim	36	Spring
9	Set plate	23	Plug	37	Plug
10	Piston shoe assy	24	Back up ring	38	O-ring
11	Ball guide	25	O-ring	39	O-ring
12	Rear cover	26	Friction plate	40	Back up ring
13	Pin	27	Plate	41	Name plate
14	O-ring	28	Parking piston	42	Rivet

2) REDUCTION GEAR

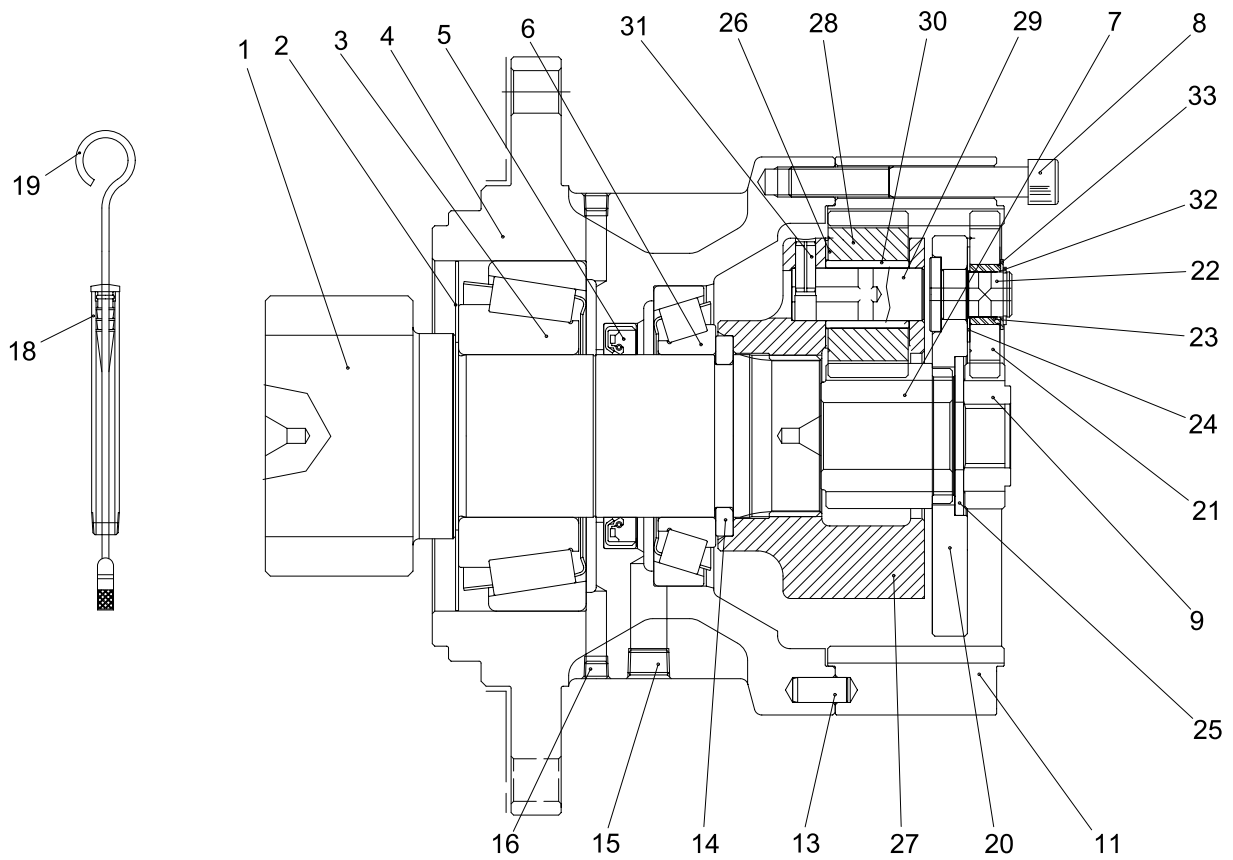

7072SM04

1	Drive shaft	13	Dowel pin	24	Thrust washer No.1
2	Bearing cover	14	Collar	25	Thrust washer No.3
3	Taper roller bearing	15	Plug	26	Thrust washer No.2
4	Case	16	Plug	27	Carrier No.2
5	Oil seal	18	Pipe	28	Planet gear No.2
6	Taper roller bearing	19	Level gauge	29	Pin No.2
7	Sun gear No.2	20	Carrier No.1	30	Bush No.2
8	Socket bolt	21	Planet gear No.1	31	Spring pin
9	Sun gear No.1	22	Pin No.1	32	Snap ring
11	Ring gear	23	Bush No.1	33	Thrust washer No.4

2. FUNCTION

1) ROTARY PART

When high pressurized oil enters a cylinder through port(a), which is the inlet of balance plate(16), hydraulic pressure acting on the piston causes axial force F. The pressure force F works via the piston(10) upon the return plate(9) which acts upon the swash plate(7) via an hydrostatic bearing. Force F1 perpendicular to swash plate(7) and force F2 perpendicular to cylinder center.

Being transferred to the cylinder block(3) through piston, force F2 causes rotational moment at surroundings of cylinder.

Since cylinder block has 9 equidistantly arrayed pistons, rotational torque is transmitted to cylinder shaft in order by several pistons connected to the inlet port of high pressurized oil. When the direction of oil flow is reversed, rotational direction of cylinder is also reversed. Output torque is given by the equation.

$$T = \frac{p \times q}{2\pi}, q = Z \cdot A \cdot \text{PCD} \cdot \tan\theta, F1 = \frac{F}{\cos\theta}, F2 = F \tan\theta, S = \text{PCD} \times \tan\theta$$

Where p : Effective difference of pressure(kgf/cm²)

q : Displacement(cc/rev)

T : Output torque(kgf · cm)

Z : Piston number(9EA)

A : Piston area(cm²)

θ : Tilting angle of swash plate(degree)

S : Piston stroke(cm)

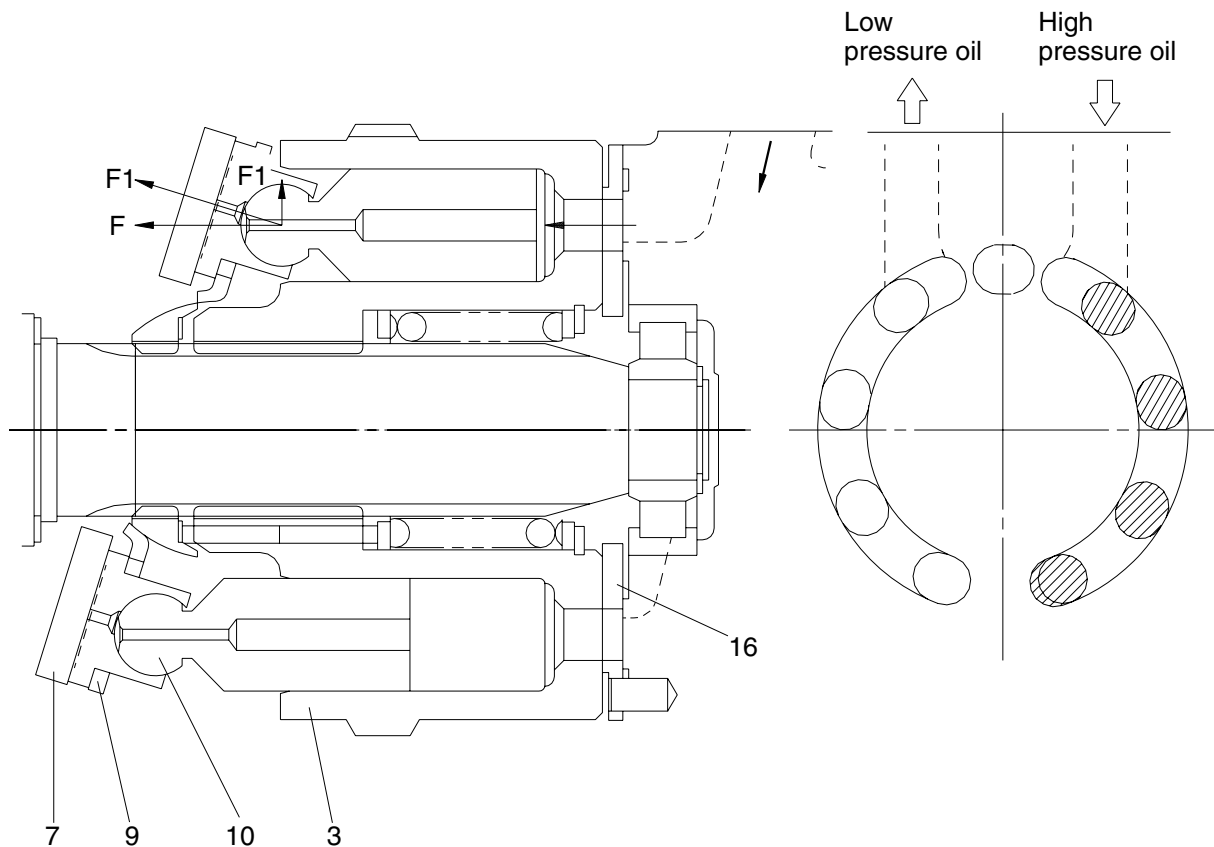

2) MAKE UP VALVE

(1) Outline

The safety valve portion consists of a check valve and safety valve.

(2) Function

When the swing is stopped, the output circuit of the motor continues to rotate because of inertia. For this reason, the pressure at the output side of the motor becomes abnormally high, and this will damage the motor. To prevent this, the oil causing the abnormal hydraulic pressure is allowed to escape from the outlet port (high-pressure side) of the motor to port **Mu**, thereby preventing damage to the motor.

Compared with a counterbalance valve, there is no closed-in pressure generated at the outlet port side when slowing down the swing speed. This means that there is no vibration when slowing down, so the ease of swing control is improved.

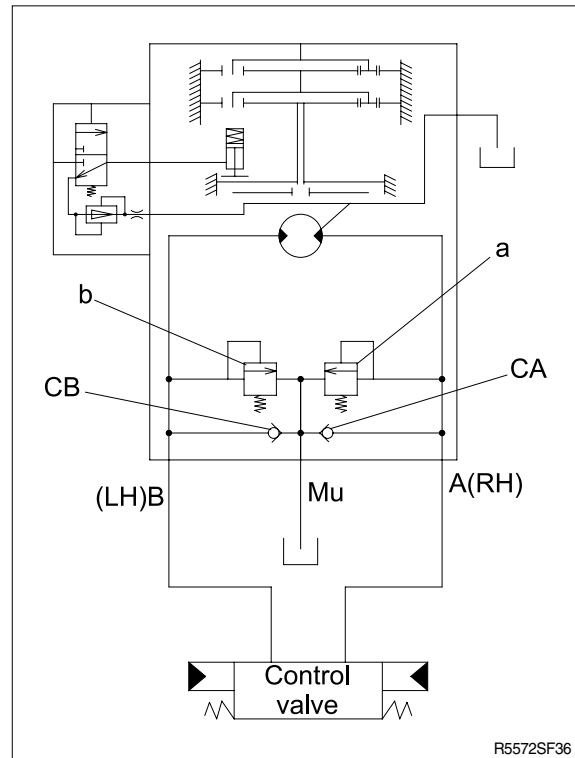

(3) Operation

① When starting swing

When the swing control lever is operated to left swing, the pressurized oil from the pump passes through the control valves and is supplied to port **B**. Because of this, the pressure at port **B** rises, starting torque is generated in the motor, and the motor starts to rotate. The oil from the outlet port of the motor passes from port **A** through the control valve and returns to the tank.

② **When stopping swing**

- When the swing control lever is returned to neutral, no pressurized oil is supplied from the pump to port **B**.

The return circuit to the tank is closed by the control valve. So the oil from the outlet port of the motor increases in pressure at port **A**. Resistance to the rotation of the motor is created, and the brake starts to act.

- The pressure at port **A** rises to the set pressure of make up valve **a**, and in this way, **a** high brake torque acts on the motor, and the motor stops.
- When make up valve **a** is being actuated, the relief oil from make up valve **a** and the oil from port **Mu** pass through check valve **CB** and are supplied to port **B**. This prevents cavitation from forming at port **B**.

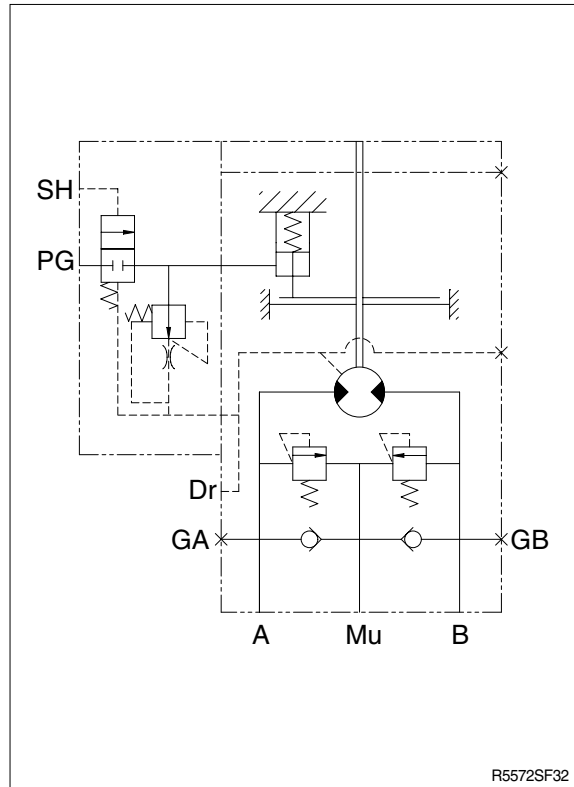

3) RELIEF VALVE

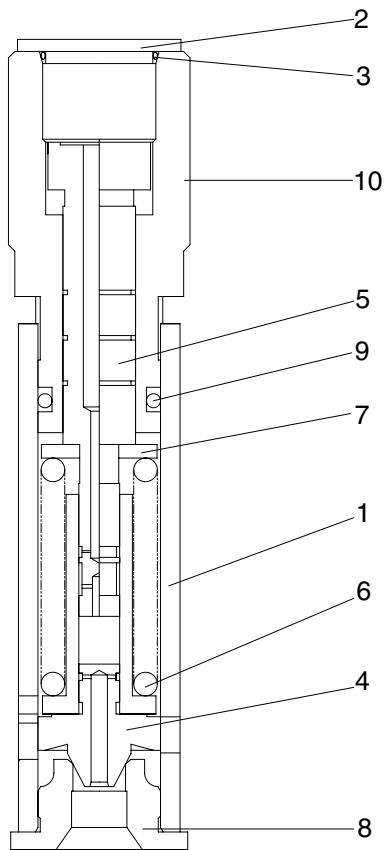

- 1 Body
- 2 Plug
- 3 O-ring
- 4 Plunger
- 5 Piston
- 6 Spring
- 7 Spring seat
- 8 Seat
- 9 O-ring
- 10 Nut

R5572SF37

(1) Construction of relief valve

The valve casing contains two cartridge type relief valves that stop the regular and reverse rotations of the hydraulic motor. The relief valves relieve high pressure at start or at stop of swing motion and can control the relief pressure in two steps, high and low, in order to insure smooth operation.

(2) Function of relief valve

Figure illustrates how the pressure acting on the relief valve is related to its rising process. Here is given the function, referring to the figure following page.

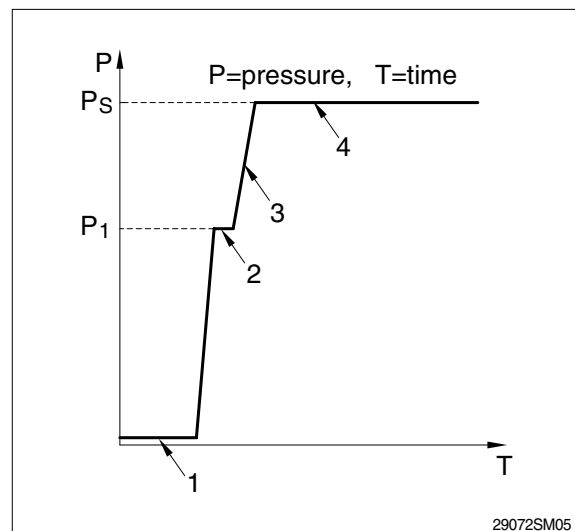

29072SM05

4) BRAKE SYSTEM

(1) Control valve swing brake system

This is the brake system to stop the swing motion of the excavator during operation.

In this system, the hydraulic circuit is throttled by the swing control valve, and the resistance created by this throttling works as a brake force to slow down the swing motion.

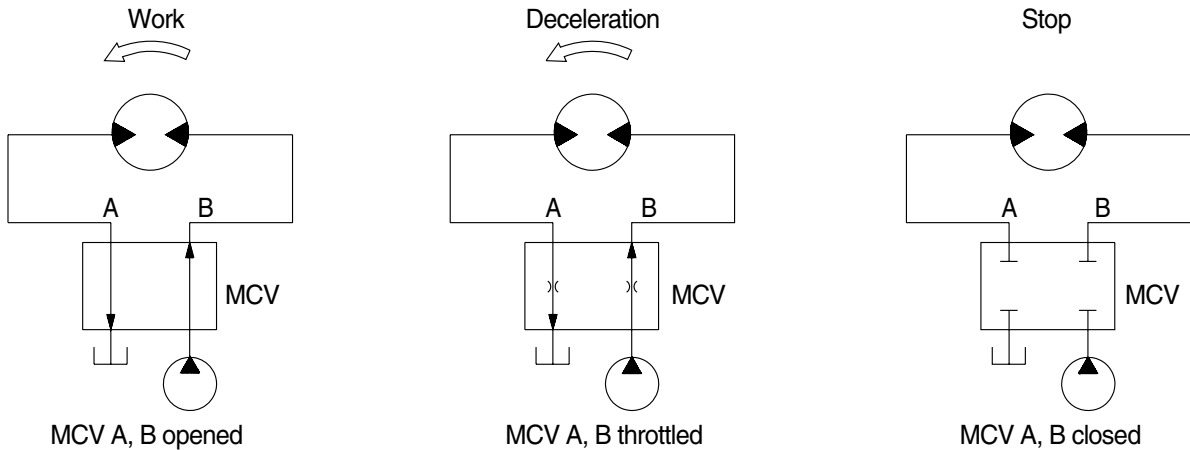

210-7 2-48(1)

(2) Mechanical swing parking brake system

The mechanical swing parking brake system is installed to prevent the upper structure from swinging downhill because of its own weight when the excavator is parked on a slope since it completely eliminates the hydraulic drift of swing motion while the excavator is on a slope, work can be done more easily and safely.

① Brake assembly

Circumferential rotation of separate plate(27) is constrained by the groove located at casing(1). When housing is pressed down by brake spring(30) through friction plate(26), separate plate(27) and brake piston(28), friction force occurs there.

Cylinder(3) is constrained by this friction force and brake acts, while brake releases when hydraulic force exceeds spring force.

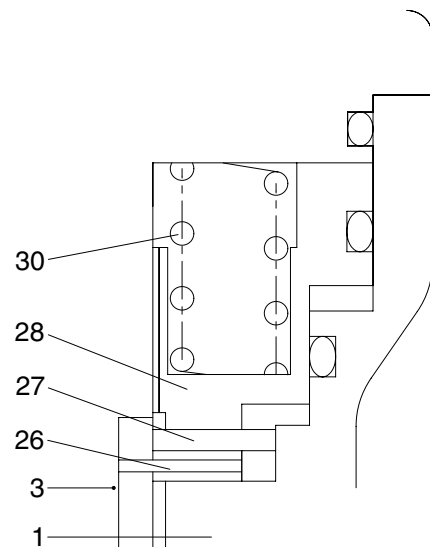

R5572SF38

1	Casing	27	Separate plate
3	Cylinder	28	Brake piston
26	Friction plate	30	Brake spring

② **Operating principle**

a. When the swing control lever(1) is set to the swing position, the pilot oil go to the swing control valve(2) and to SH of the time delay valve(3) via the shuttle valve(4), this pressure move spool(5) to the leftward against the force of the spring(8), so pilot pump charged oil(P4) goes to the chamber G.

This pressure is applied to move the piston(28) to the upward against the force of the spring(30). Thus, it releases the brake force.

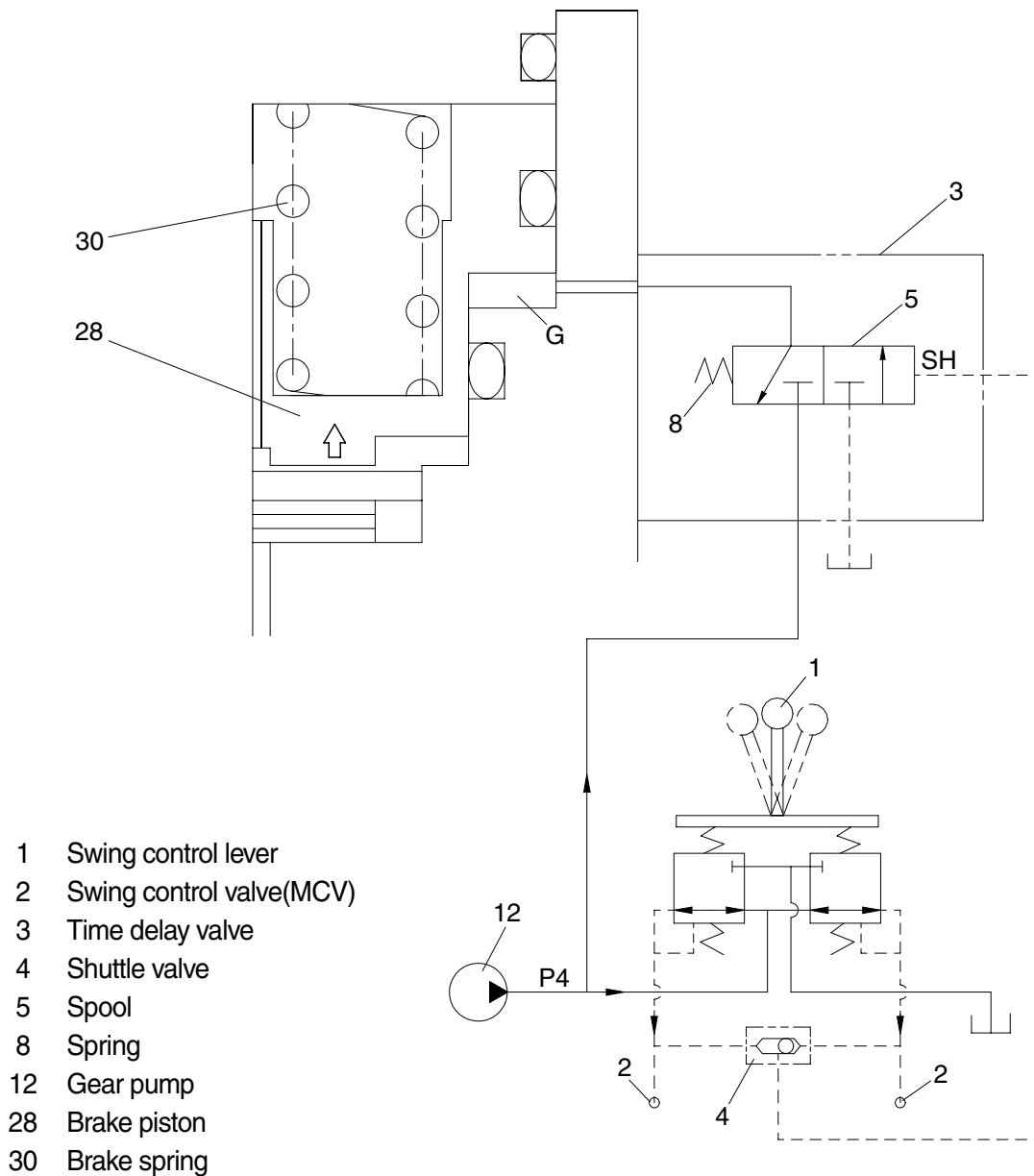

R5572SF39

b. When the swing control lever(1) is set the neutral position, the time delay valve(3) shifts the neutral position and the pilot oil blocked chamber G. Then, the piston(28) is moved lower by spring(30) force and the return oil from the chamber G is drain.

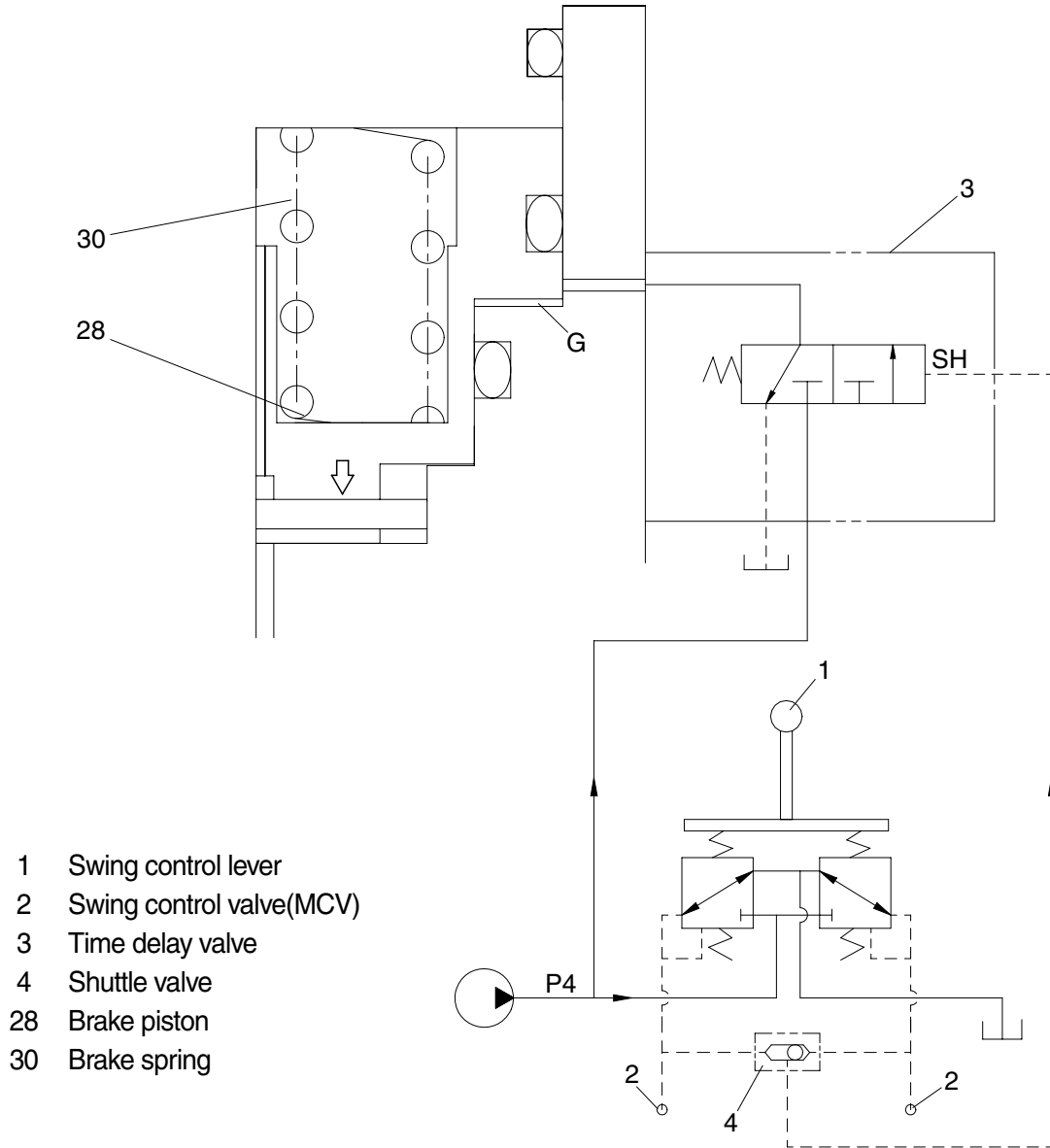

- 1 Swing control lever
- 2 Swing control valve(MCV)
- 3 Time delay valve
- 4 Shuttle valve
- 28 Brake piston
- 30 Brake spring

R5572SF40

GROUP 4 TRAVEL DEVICE

1. CONSTRUCTION

Travel device consists travel motor and gear box.

Travel motor includes brake valve, parking brake and high/low speed changeover mechanism.

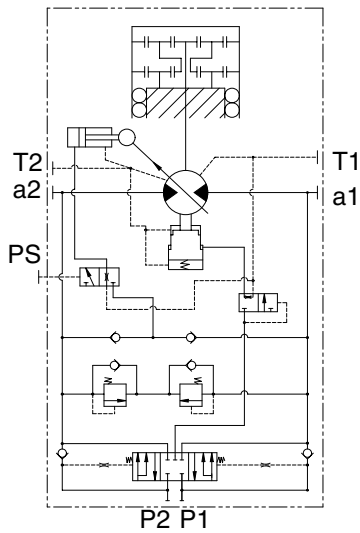
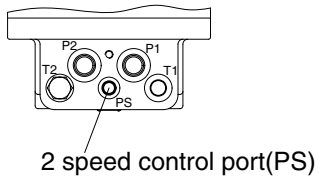
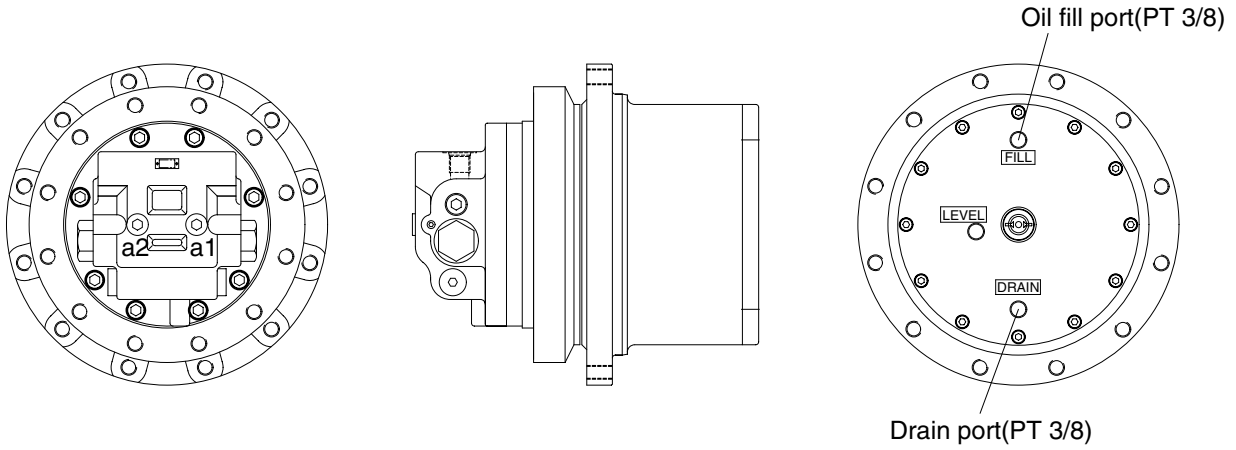

Port	Port name	Port size
P1	Main port	PF 1/2
P2	Main port	PF 1/2
a1, a2	Gauge port	PT 1/4
T1, T2	Drain port	PF 3/8
PS	2 speed control port	PF 1/4

1) BASIC STRUCTURE

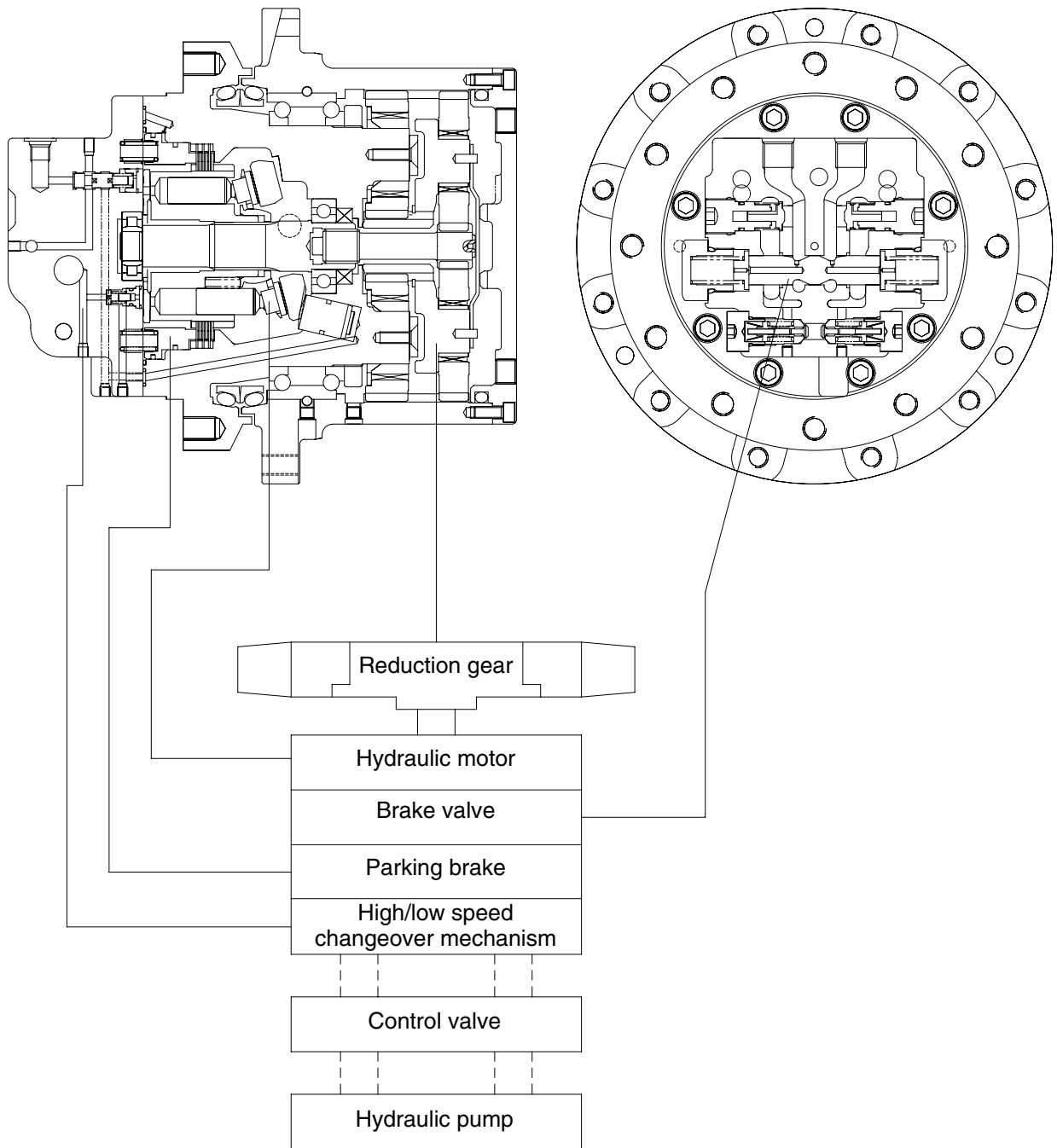

7072TM03

2) STRUCTURE

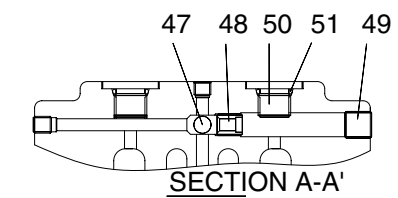
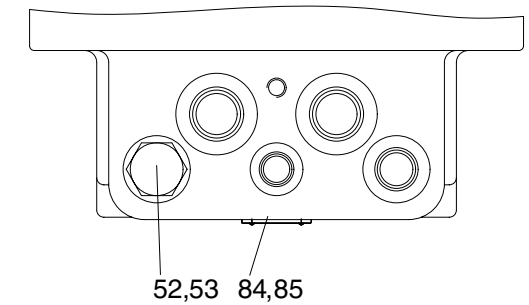
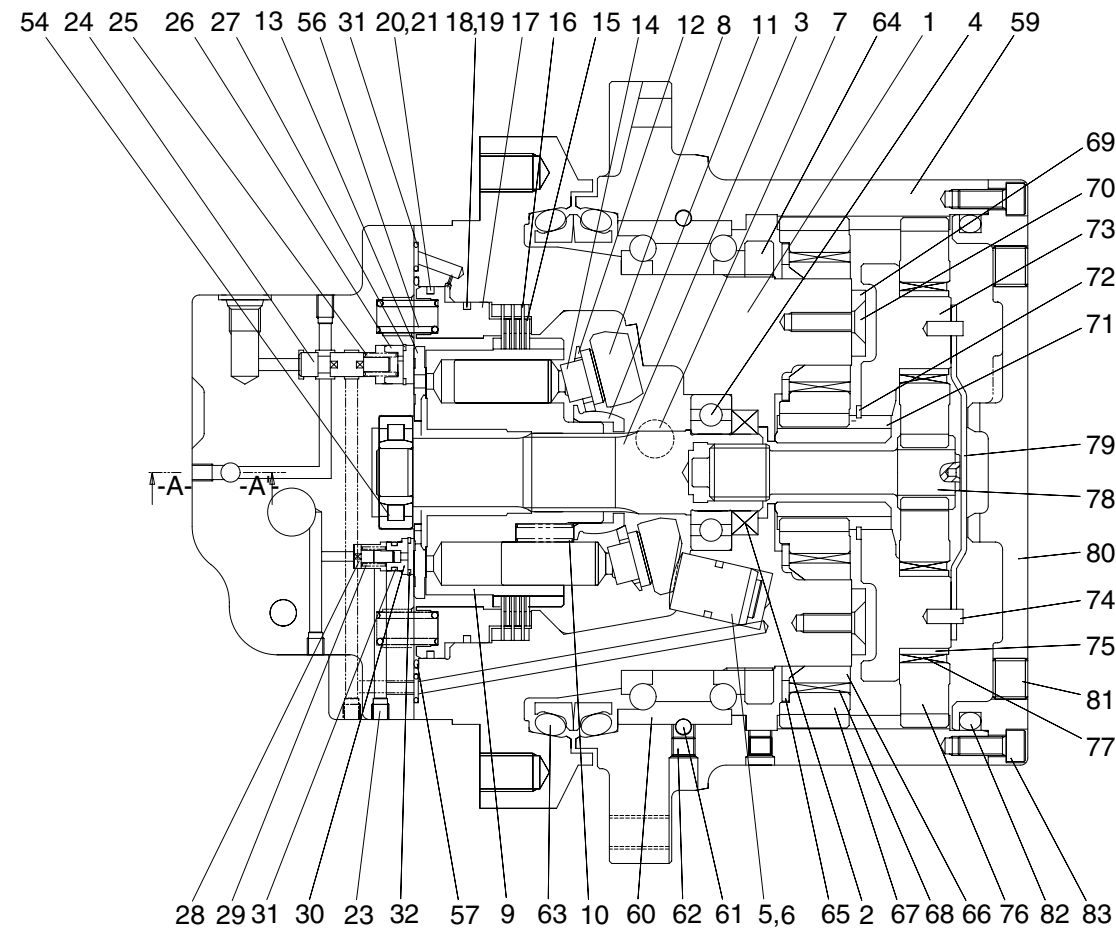
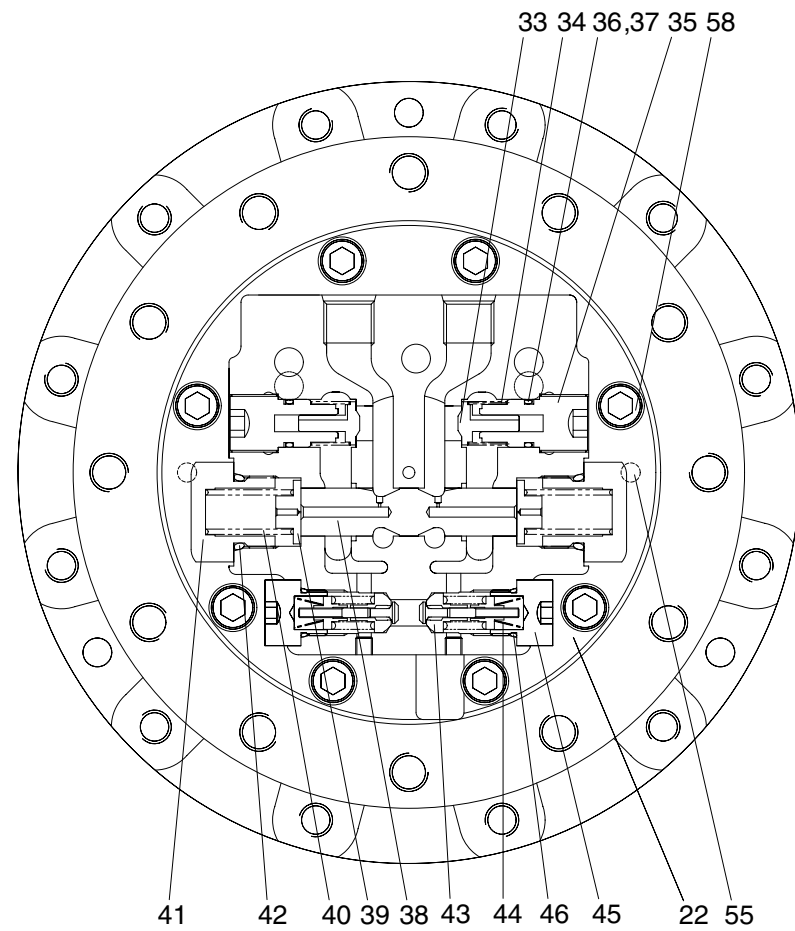

1 Shaft casing	16 Parking plate	31 O-ring	45 Plug	59 Ring gear	73 Carrier
2 Oil seal	17 Parking piston	32 Snap ring	46 O-ring	60 Angular bearing	74 Spring pin
3 Shaft	18 O-ring	33 Check	47 Steel ball	61 Steel ball	75 Collar
4 Bearing	19 Back up ring	34 Spring	48 Check seat	62 Plug	76 Planetary gear(B)
5 Swash piston	20 O-ring	35 Plug	49 Plug	63 Floating seal	77 Needle bearing
6 Piston ring	21 Back up ring	36 O-ring	50 Plug	64 Nut	78 Drive gear
7 Swash steel ball	22 Rear cover	37 Back up ring	51 O-ring	65 Washer	79 Thrust plate
8 Swash plate	23 Plug	38 Main spool	52 Roller bearing	66 Collar	80 Ring gear cover
9 Cylinder block	24 Spool	39 Spring seat	53 O-ring	67 Planetary gear(A)	81 Plug
10 Spring	25 Spring	40 Spring	54 Hex plug	68 Needle bearing	82 O-ring
11 Ball guide	26 Stopper	41 Plug	55 Parallel pin	69 Plate	83 Wrench bolt
12 Set plate	27 Snap ring	42 O-ring	56 Spring	70 Bolt	84 Name plate
13 Valve plate	28 Check	43 Relief valve assembly	57 O-ring	71 Sun gear	85 Rivet
14 Piston assembly	29 Spring	44 Spring	58 Wrench bolt	72 Snap ring	86 Seal kit
15 Friction plate	30 Seat				

7072TM02

2. PRINCIPLE OF DRIVING

1) GENERATING THE TURNING FORCE

The high hydraulic supplied from a hydraulic pump flows into a cylinder(9) through valve casing of motor(22), and valve plate(13).

The high hydraulic is built as flowing on one side of Y-Y line connected by the upper and lower sides of piston(14).

The high hydraulic can generate the force, $F1 = P \times A$ (P : Supplied pressure, A : water pressure area), like following pictures, working on a piston.

This force, F1, is divided as N1 thrust partial pressure and W1 radial partial pressure, in case of the plate(8) of a tilt angle, α .

W1 generates torque, $T = W1 \times R1$, for Y-Y line connected by the upper and lower sides of piston as following pictures.

The sum of torque ($\sum W1 \times R1$), generated from each piston(4~5pieces) on the side of a high hydraulic, generates the turning force.

This torque transfers the turning force to a cylinder(9) through a piston; because a cylinder is combined with a turning axis and spline, a turning axis rotates and a turning force is sent.

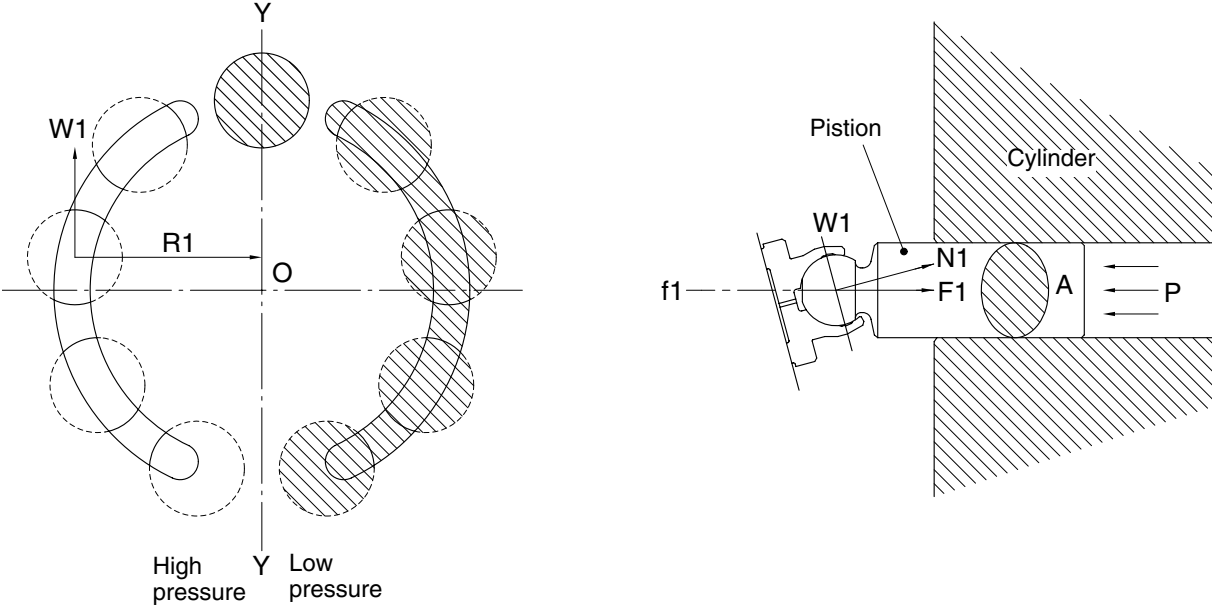

21078TM05

2) WORKING OF RELIEF VALVE

Relief valve carries on two functions of followings.

- (1) It standardizes a pressure in case of driving a hydraulic motor ; bypasses and extra oil in a motor inlet related to acceleration of an inertia to an outlet.
- (2) In case of an inertia stopped, it forces an equipment stopped, according to generating the pressure of a brake on the projected side.
Room A is always connected with port A of a motor. If the pressure of port is increased, press poppet B. And if it is higher than the setting pressure of a spring, the oil of an hydraulic flows from room A to port B, because poppet A is detached from the contact surface of seat A.

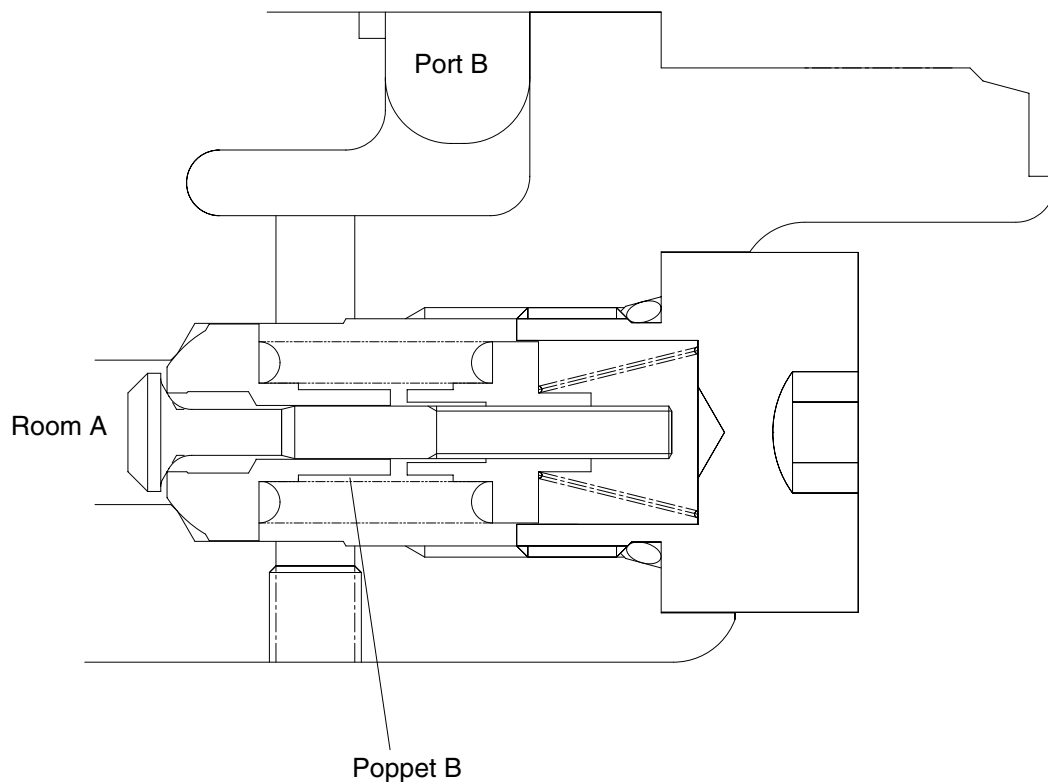

7072TM04

3) WORKING OF BRAKE

Brake operates the pressure supplied through SPOOL(simultaneous peripheral operation online) installed in rear cover(22) to the part of parking piston(17) and releases a brake.

When the pressure does not work, the brake always runs.

The force of a brake is generated by the frictional force among a plate(16), brake piston(17) and a cylinder block(9) connected through spline which are fixed by shaft casing(1) with friction plate(15).

When a pressure does not work on the part of piston, brake spring presses brake piston; oil in a brake room flows into the drain of a motor through an orifice; in that time, brake piston compresses a frictional plate(15) and a detached plate in the middle of shaft casing and brake piston according to the force plate springs(56); finally, it makes a frictional force.

This frictional force helps the brake fixing a turning axis(3) connected by a cylinder and spline operated.

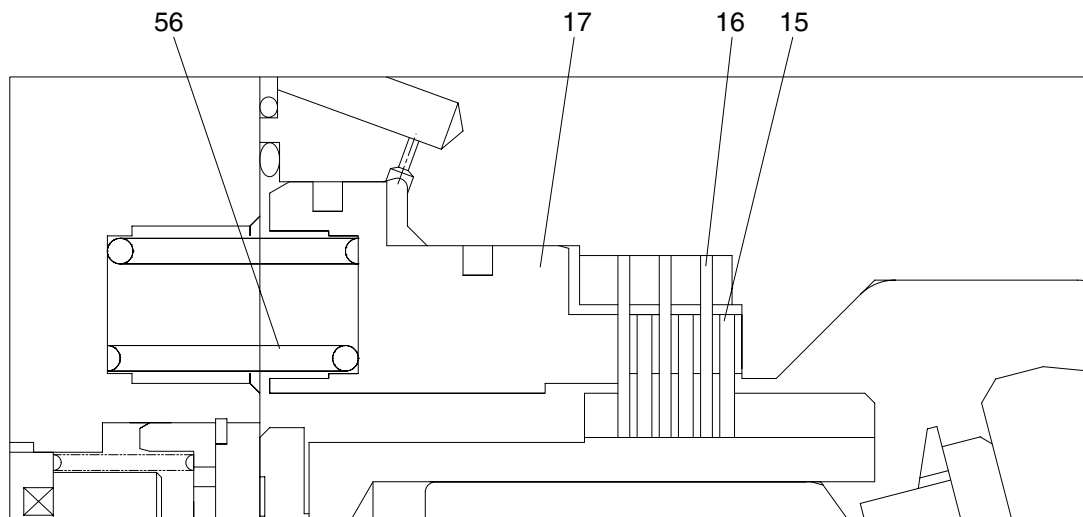

7072TM05

4) COUNTERBALANCE VALVE

Av port is connected into a hydraulic pump and Bv port is into a tank. Hydraulic pump supplying oil is come into Av → Cv room. In accordance with SPRING FORCE(40) that is working on the spool's side it moves to the SPOOL(38) on the right side which is medium position and that time MOTOR is turning.

When the SPOOL(38) is come back to the medium position that time hydraulic motor is stopped. In accordance with SPOOL's returning speed and shape control the working oil that is returning from hydraulic motor smoothly stopping the motor.

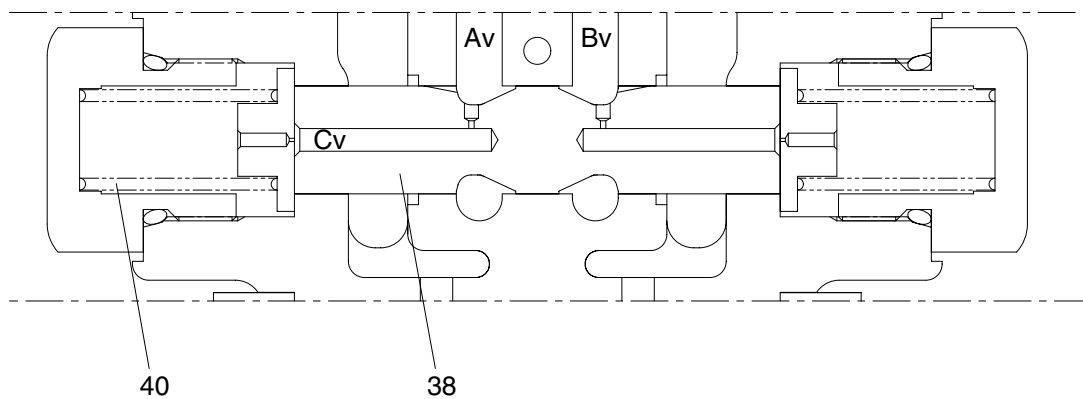

7072TM06

GROUP 5 RCV LEVER

1. STRUCTURE

The casing has the oil inlet port P(Primary pressure) and the oil outlet port T(Tank). In addition the secondary pressure is taken out through ports 1,2,3 and 4 provided at the bottom face.

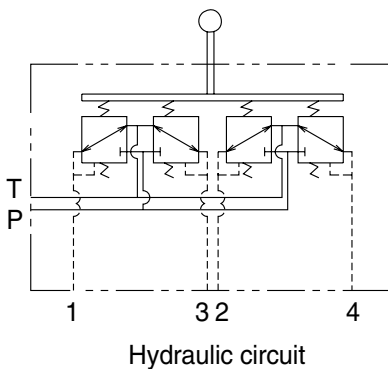
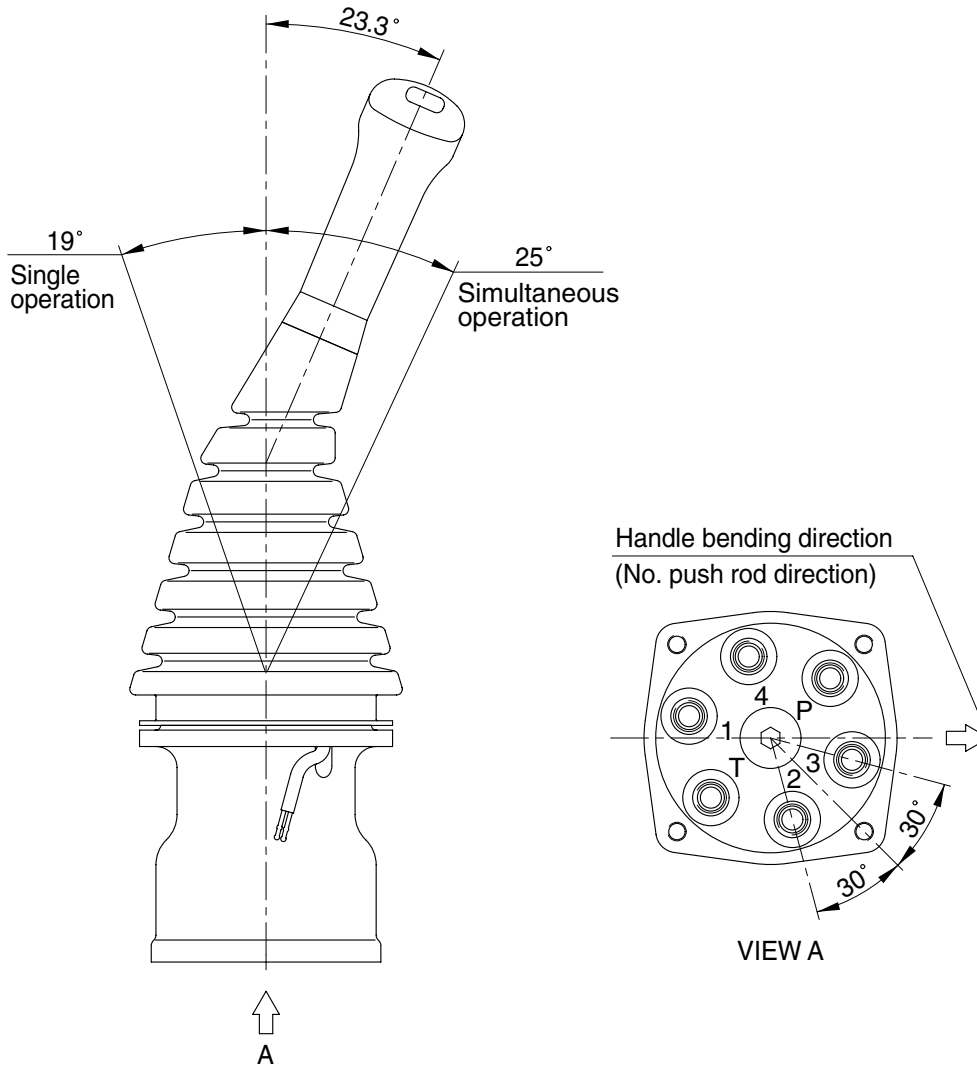

Port	LH	RH	Port size
P	Pilot oil inlet port	Pilot oil inlet port	PF 1/4
T	Pilot oil return port	Pilot oil return port	
1	Left swing port	Bucket out port	
2	Arm in port	Boom down port	
3	Right swing port	Bucket in port	
4	Arm out port	Boom up port	

25032RL01

CROSS SECTION

The construction of the pilot valve is shown in the attached cross section drawing. The casing has vertical holes in which reducing valves are assembled.

The pressure reducing section is composed of the spool(5), spring(7) for setting secondary pressure, return spring(10), stopper(9), spring seat(8) and shim(6). The spring for setting the secondary pressure has been generally so preset that the secondary pressure is 5 to 20.5kgf/cm²(Depending on the type). The spool is pushed against the push rod(14) by the return spring.

When the push rod is pushed down by tilting the handle, the spring seat comes down simultaneously and changes setting of the secondary pressure spring.

1	Case	12	Rod seal	22	Handle connector
2	Plug	13	O-ring	23	Nut
3	Plug	14	Push rod	24	Insert
4	O-ring	15	Plate	25	Boot
5	Spool	16	Bushing	26	Handle
6	Shim	17	Joint assembly	27	Switch assembly
7	Spring	18	Swash plate	28	Screw
8	Spring seat	19	Adjusting nut	29	Switch assembly
9	Stopper	20	Lock nut	30	Switch cover
10	Spring	21	O-ring	40	Boot
11	Plug				

CROSS SECTION

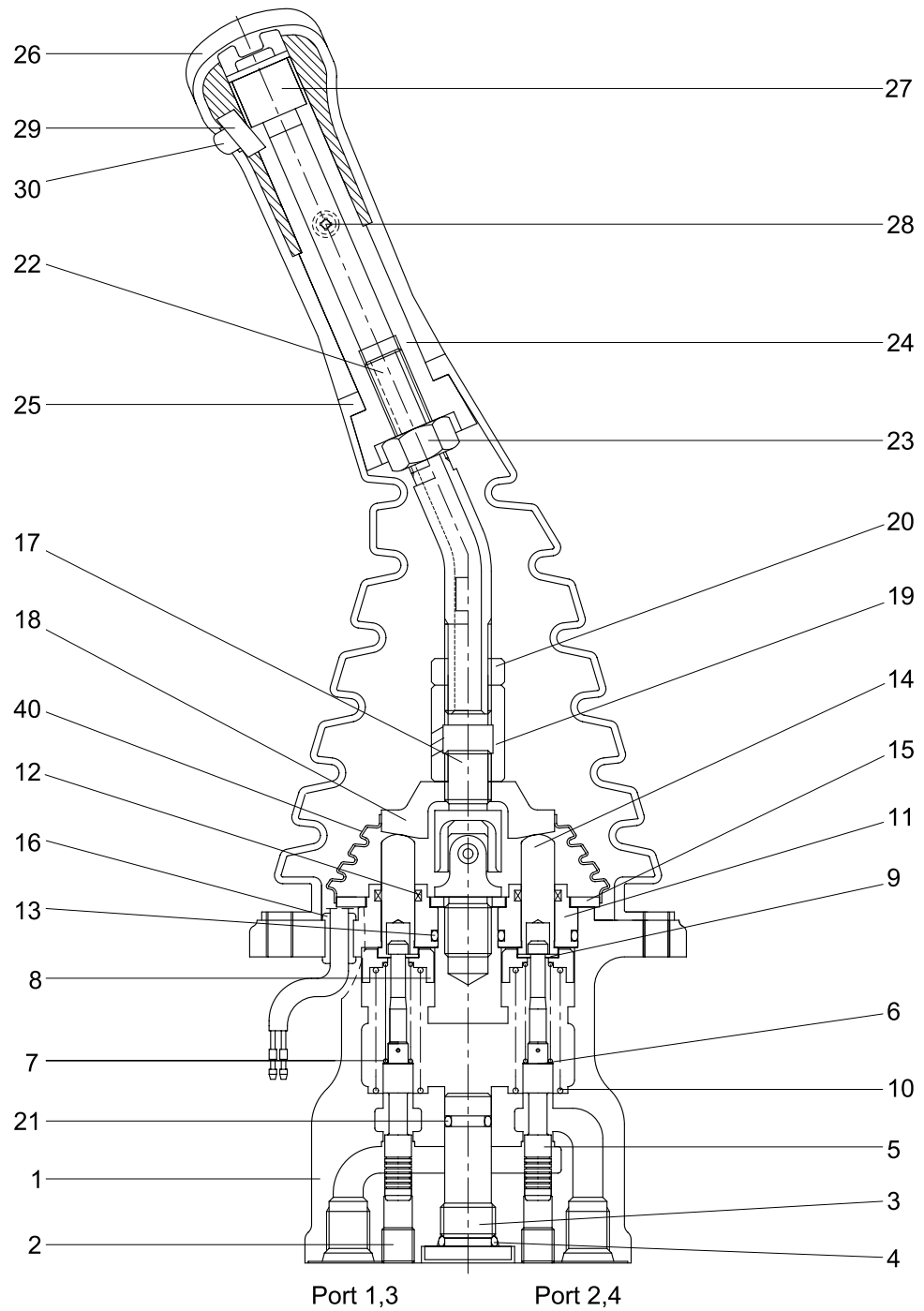

14072SF80

2. FUNCTIONS

1) FUNDAMENTAL FUNCTIONS

The pilot valve is a valve that controls the spool stroke, direction, etc of a main control valve. This function is carried out by providing the spring at one end of the main control valve spool and applying the output pressure(Secondary pressure) of the pilot valve to the other end.

For this function to be carried out satisfactorily, the pilot valve is composed of the following elements.

- (1) Inlet port(P) where oil is supplied from hydraulic pump.
- (2) Output ports(1, 2, 3 & 4) to apply pressure supplied from inlet port to ends of control valve spools.
- (3) Tank port(T) necessary to control the above output pressure.
- (4) Spool to connect output port to inlet port or tank port.
- (5) Mechanical means to control output pressure, including springs that work on the above spools.

2) FUNCTIONS OF MAJOR SECTIONS

The functions of the spool(5) are to receive the supply oil pressure from the hydraulic pump at its port P, and to change over oil paths to determine whether the pressure oil of port P is led to output ports 1, 2, 3 & 4 or the output port pressure oil to tank port T.

The spring(7) works on this spool to determine the output pressure.

The change the deflection of this spring, the push rod(14) is inserted and can slide in the plug(11).

For the purpose of changing the displacement of the push rod through the switch plate(19) and adjusting nut(20) are provided the handle(27) that can be tilted in any direction around the fulcrum of the universal joint(18) center.

The spring(10) works on the case(1) and spring seat(8) and tries to return the push rod(14) to the zero-displacement position irrespective of the output pressure, securing its resetting to the center position.

This also has the effect of a reaction spring to give appropriate control feeling to the operator.

3) OPERATION

The operation of the pilot valve will be described on the basis of the hydraulic circuit diagram shown below and the attached operation explanation drawing.

The diagram shown below is the typical application example of the pilot valve.

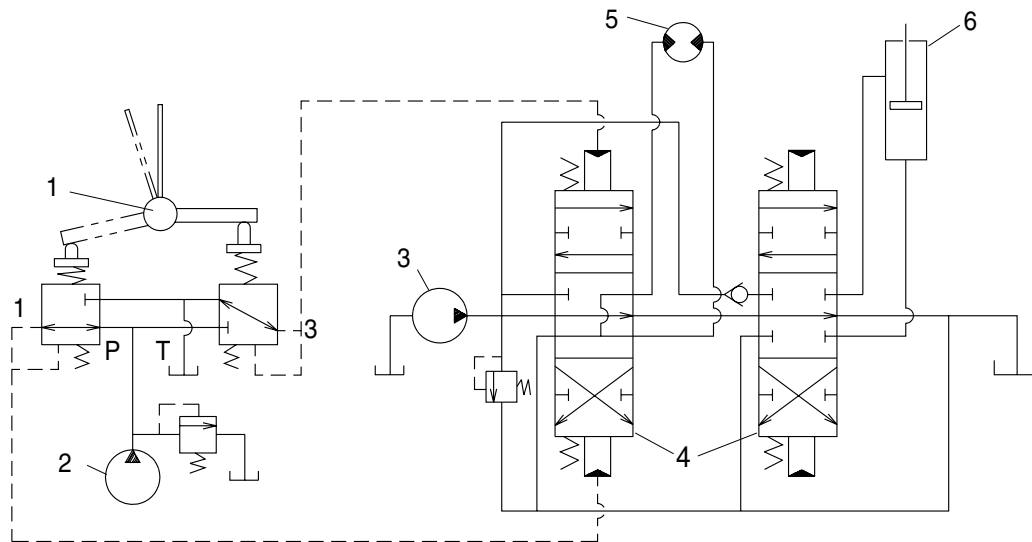

140LC-7 기타2-70

1 Pilot valve
2 Pilot pump

3 Main pump
4 Main control valve

5 Hydraulic motor
6 Hydraulic cylinder

(1) Case where handle is in neutral position

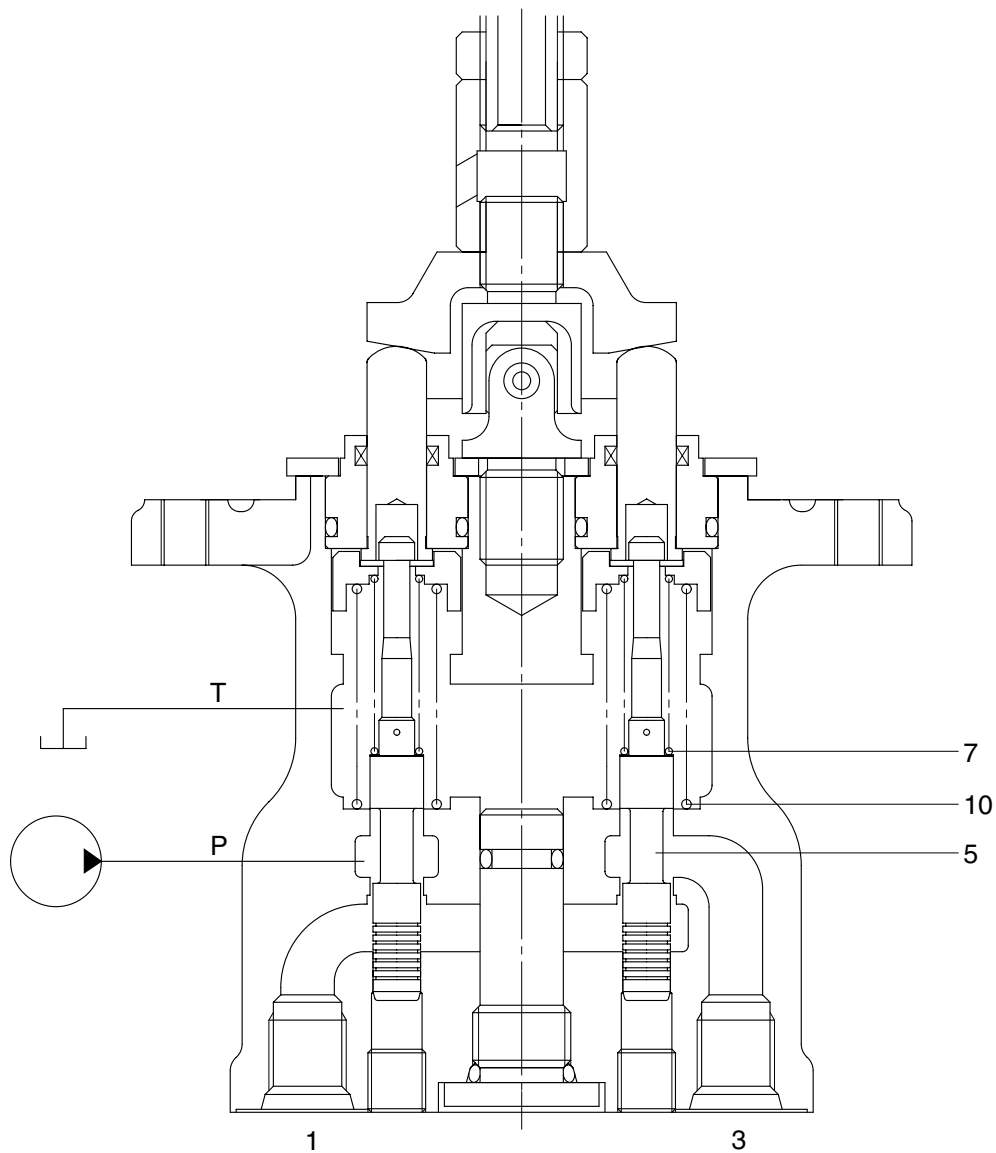

25032RL03

The force of the spring(7) that determines the output pressure of the pilot valve is not applied to the spool(5). Therefore, the spool is pushed up by the spring(10) to the position of port(1, 3) in the operation explanation drawing. Then, since the output port is connected to tank port T only, the output port pressure becomes equal to tank pressure.

(2) Case where handle is tilted

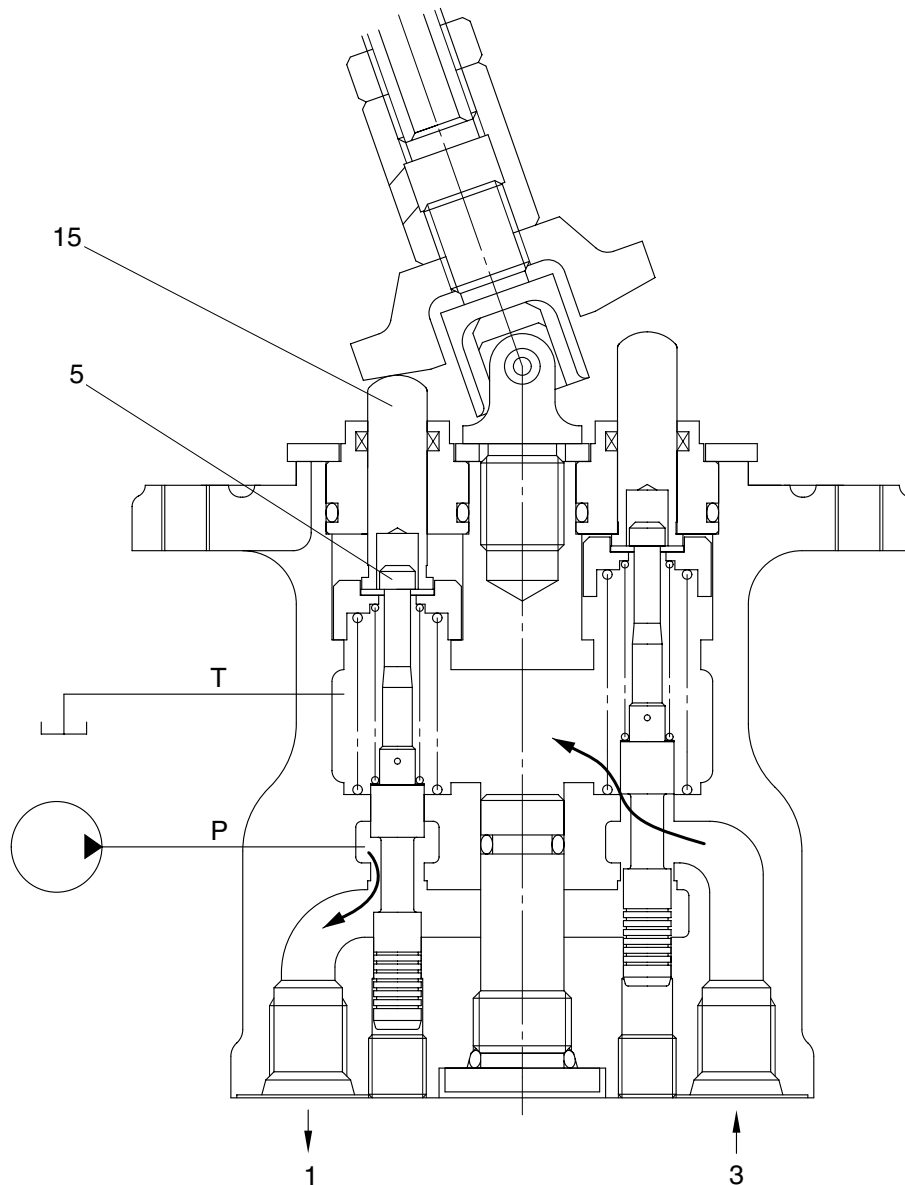

25032RL04

When the push rod(14) is stroked, the spool(5) moves downwards.

Then port P is connected with port(1) and the oil supplied from the pilot pump flows through port(1) to generate the pressure.

When the pressure at port(1) increases to the value corresponding to the spring force set by tilting the handle, the hydraulic pressure force balances with the spring force. If the pressure at port(1) increases higher than the set pressure, port P is disconnected from port(1) and port T is connected with port(1). If it decreases lower than the set pressure, port P is connected with port(1) and port T is disconnected from port 1.

In this manner the secondary pressure is kept at the constant value.

Besides, in some type, when the handle is tilted more than a certain angle, the upper end of the spool contacts with the inside bottom of the push rod and the output pressure is left to be connected with port P.

GROUP 6 RCV PEDAL

1. STRUCTURE

The casing(Spacer) has the oil inlet port P(Primary pressure), and the oil outlet port T(Tank). In addition the secondary pressure is taken out through ports 1,2,3 and 4 provided at the bottom face.

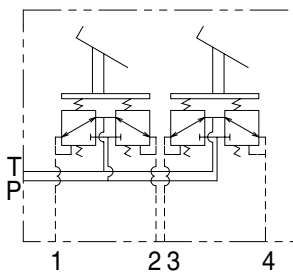
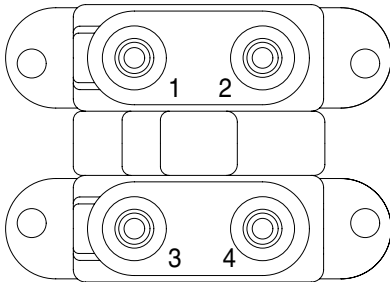
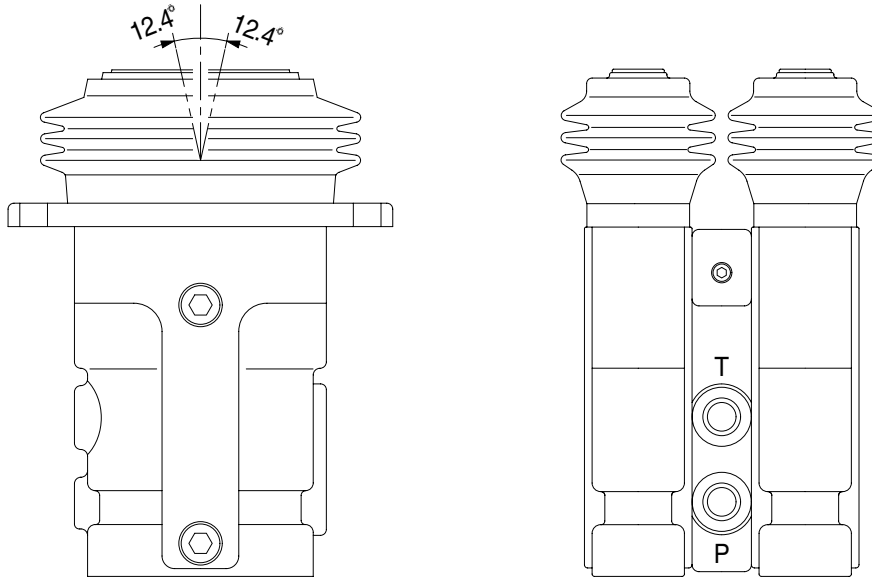

Hydraulic circuit

Port	Port	Port size
P	Pilot oil inlet port	PF 1/4
T	Pilot oil return port	
1	Travel(LH, Forward)	
2	Travel(LH, Backward)	
3	Travel(RH, Forward)	
4	Travel(RH, Backward)	

CROSS SECTION

The construction of the RCV pedal is shown in the below drawing. The casing has vertical holes in which reducing valves are assembled.

The pressure reducing section is composed of the spool(8), spring(6) for setting secondary pressure, return spring(10), stopper(9), and spring seat(7). The spring for setting the secondary pressure has been generally so preset that the secondary pressure is 5 to 19 kgf/cm² (depending on the type). The spool is pushed against the push rod(14) by the return spring.

When the push rod is pushed down by tilting pedal, the spring seat comes down simultaneously and changes setting of the secondary pressure spring.

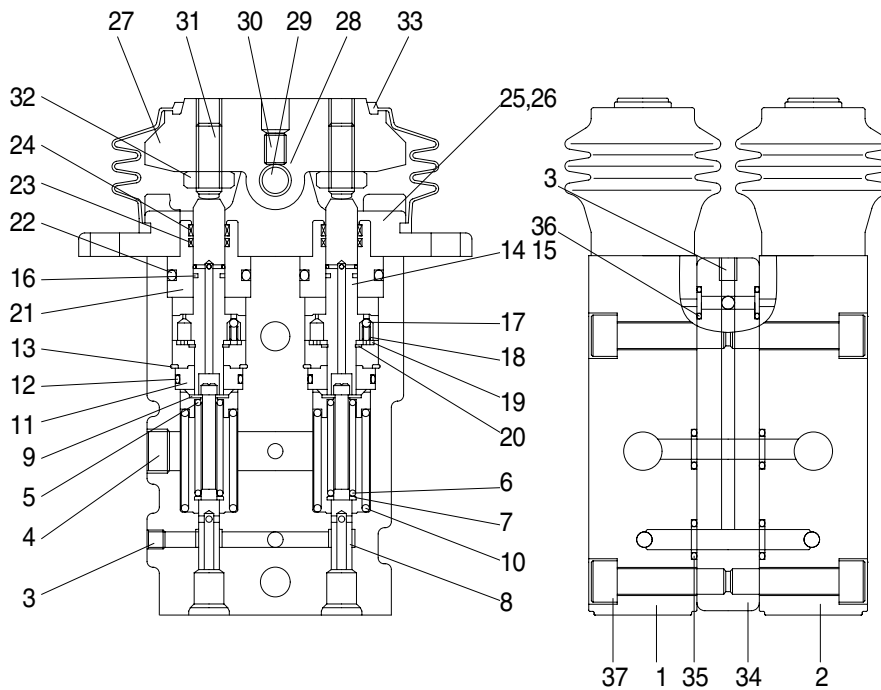

1	Body(1)	14	Push rod	26	Bolt
2	Body(2)	15	Spring pin	27	Cam
3	Plug	16	Seal	28	Bushing
4	Plug	17	Steel ball	29	Cam shaft
5	Spring seat	18	Spring	30	Set screw
6	Spring	19	Plate	31	Set screw
7	Spring seat	20	Snap ring	32	Nut
8	Spool	21	Plug	33	Bellows
9	Stopper	22	O-ring	34	Space
10	Spring	23	Rod seal	35	O-ring
11	Rod guide	24	Dust seal	36	O-ring
12	O-ring	25	Cover	37	Bolt
13	Snap ring				

14072SF70

2. FUNCTION

1) FUNDAMENTAL FUNCTIONS

The pilot valve is a valve controls the spool stroke, direction, etc of a main control valve. This function is carried out by providing the spring at one end of the main control valve spool and applying the output pressure(Secondary pressure) of the pilot valve to the other end.

For this function to be carried out satisfactorily, the pilot valve is composed of the following elements.

- (1) Inlet port(P) where oil is supplied from hydraulic pump.
- (2) Output port(1, 2, 3 & 4) to apply pressure supplied from inlet port to ends of control valve spools.
- (3) Tank port(T) necessary to control the above output pressure.
- (4) Spool to connect output port to inlet port tank port.
- (5) Mechanical means to control output pressure, including springs that work on the above spools.

2) FUNCTIONS OF MAJOR SECTIONS

The functions of the spool(8) are to receive the supply oil pressure from the hydraulic pump at its port P, and to change over oil paths to determine whether the pressure oil of port P is led to output ports 1, 2, 3 & 4 or the output spool to determine the output pressure.

The spring(6) works on this spool to determine the output pressure.

The change the deflection of this spring, the push rod(14) is inserted and can slide in the plug(21).

For the purpose of changing th displacement of the push rod through the cam(27) and adjusting nut(32) are provided the pedal that can be tilted in any direction around the fulcrum of the cam(27) center.

The spring(10) works on the casing(1) and spring seat(7) and tries to return the push rod(14) to the zero-displacement position irrespective of the output pressure, securing its resetting to the center position.

This also has the effect of a reaction spring to give appropriate control feeling to the operator.

3) OPERATION

The operation of the pilot valve will be described on the basis of the hydraulic circuit diagram shown below and the attached operation explanation drawing.

The diagram shown below is the typical application example of the pilot valve.

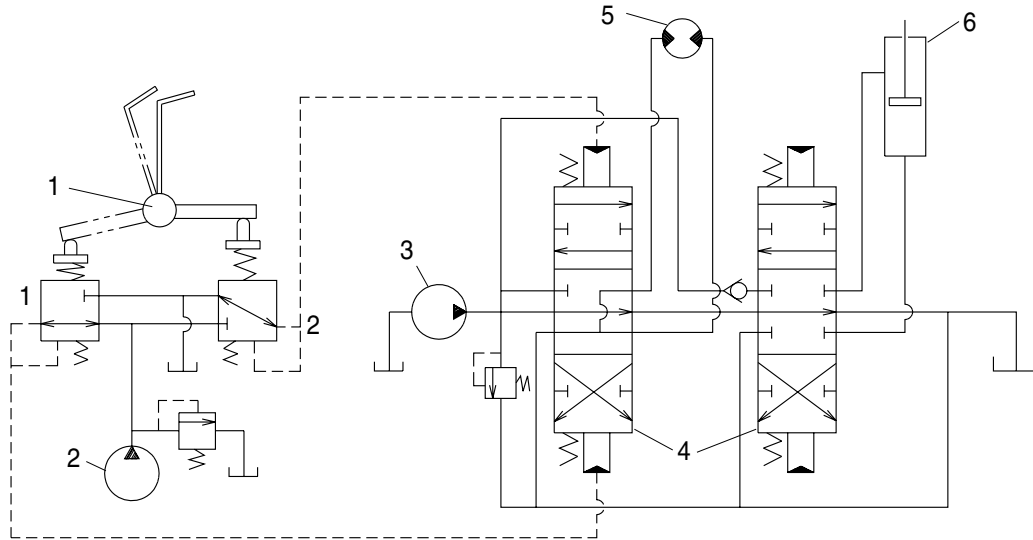

140LC-7 기타2-76

1 Pilot valve
2 Pilot pump

3 Main pump
4 Main control valve

5 Hydraulic motor
6 Hydraulic cylinder

(1) Case where pedal is in neutral position

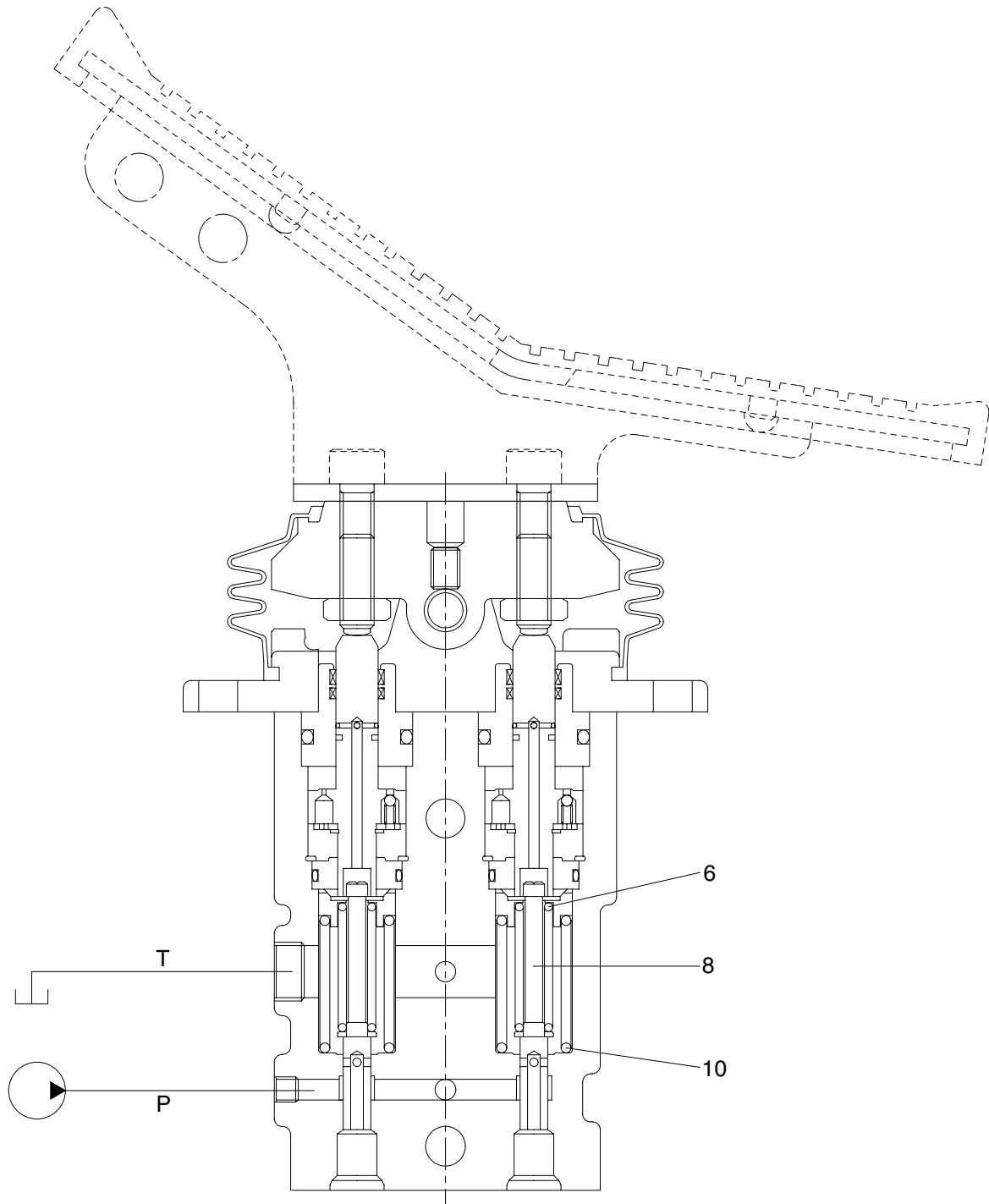

14072SF74

The force of the spring(6) that determines the output pressure of the pilot valve is not applied to the spool(8). Therefore, the spool is pushed up by the spring(10) to the position of port 2 in the operation explanation drawing. Then, since the output port is connected to tank port T only, the output port pressure becomes equal to tank pressure.

(2) Case where pedal is tilted

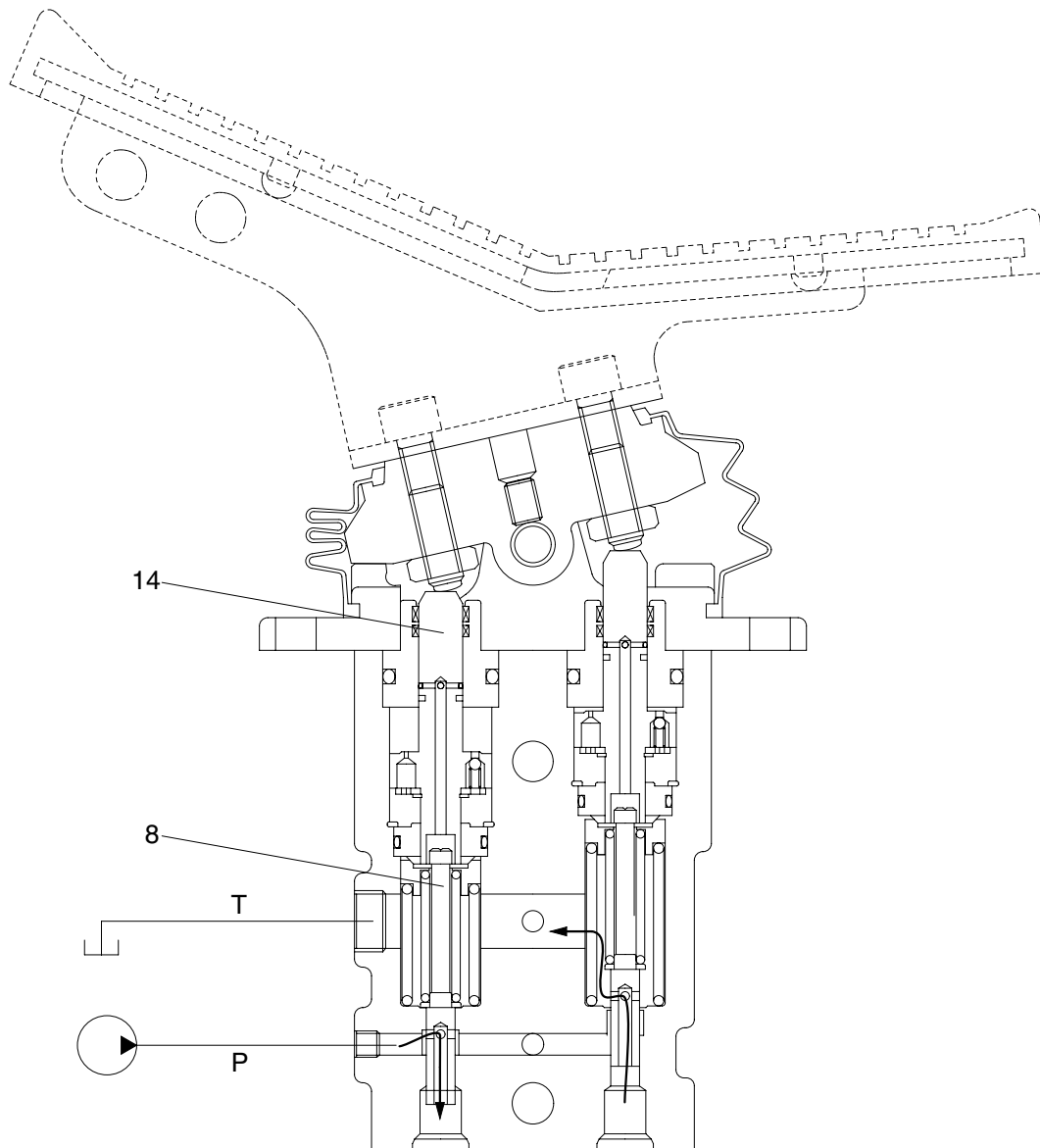

14072SF75

When the push rod(14) is stroked, the spool(8) moves downwards.

Then port P is connected with port 1, and the oil supplied from the pilot pump flows through port 1 to generate the pressure.

When the pressure at port 1 increases to the value corresponding to the spring force set by tilting the handle, the hydraulic pressure force balances with the spring force. If the pressure at port 1 increases higher than the set pressure, port P is disconnected from port 1 and port T is connected with port 1. If it decreases lower than the set pressure, port P is connected with port 1 and port T is disconnected from port 1.

In this manner the secondary pressure is kept at the constant value.

Besides, in some type, when the handle is tilted more than a certain angle, the upper end of the spool contacts with inside bottom of the push rod and the output pressure is left to be connected with port P.