

GROUP 6 TRAVEL DEVICE

1. REMOVAL AND INSTALL

1) REMOVAL

- (1) Swing the work equipment 90° and lower it completely to the ground.
- (2) Operate the control levers and pedals several times to release the remaining pressure in the hydraulic piping.
- (3) Loosen the breather slowly to release the pressure inside the hydraulic tank.

▲ Escaping fluid under pressure can penetrate the skin causing serious injury.

※ When pipes and hoses are disconnected, the oil inside the piping will flow out, so catch it in oil pan.

- (4) Remove the track shoe assembly.
For details, see **removal of track shoe assembly**.
- (5) Remove the cover.
- (6) Remove the hose.
※ Fit blind plugs to the disconnected hoses.
- (7) Remove the bolts and the sprocket.
- (8) Sling travel device assembly(1).
- (9) Remove the mounting bolts(2), then remove the travel device assembly.
· Weight : 80kg(180lb)

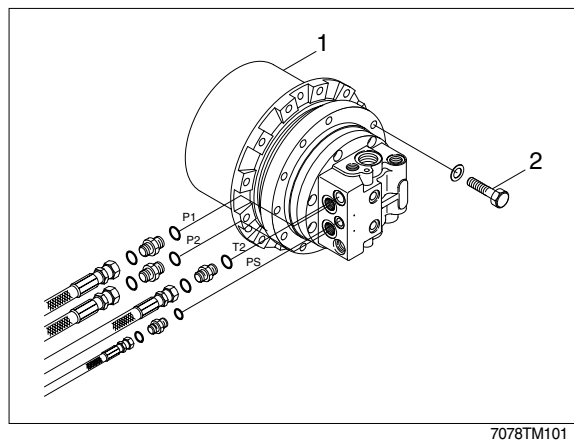

2) INSTALL

- (1) Carry out installation in the reverse order to removal.
- (2) Bleed the air from the travel motor.
 - ① Remove the air vent plug.
 - ② Pour in hydraulic oil until it overflows from the port.
 - ③ Tighten plug lightly.
 - ④ Start the engine, run at low idling, and check oil come out from plug.
 - ⑤ Tighten plug fully.
- (3) Confirm the hydraulic oil level and check the hydraulic oil leak or not.

2. TRAVEL MOTOR

2) STRUCTURE

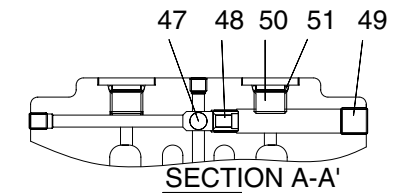
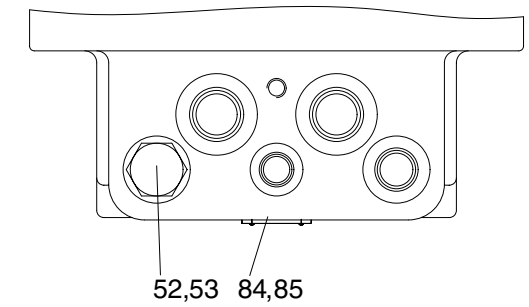
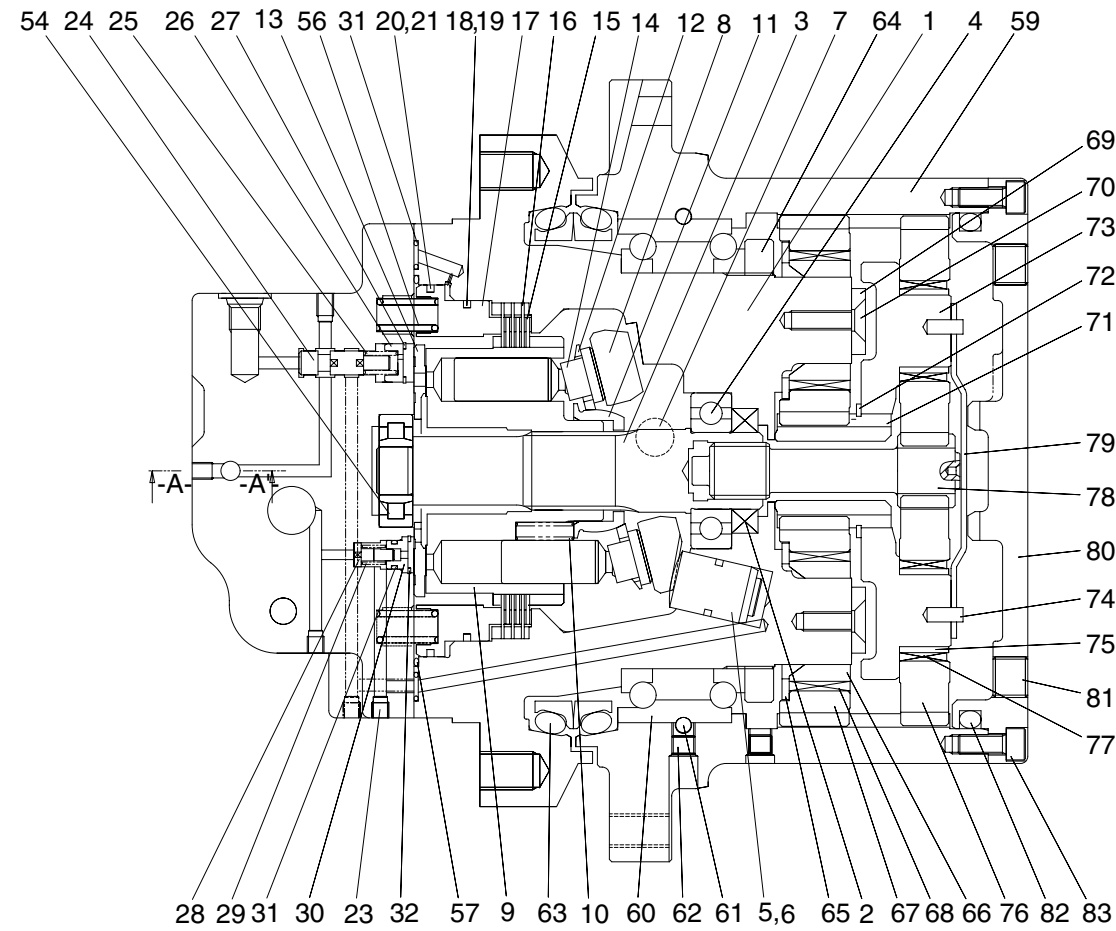
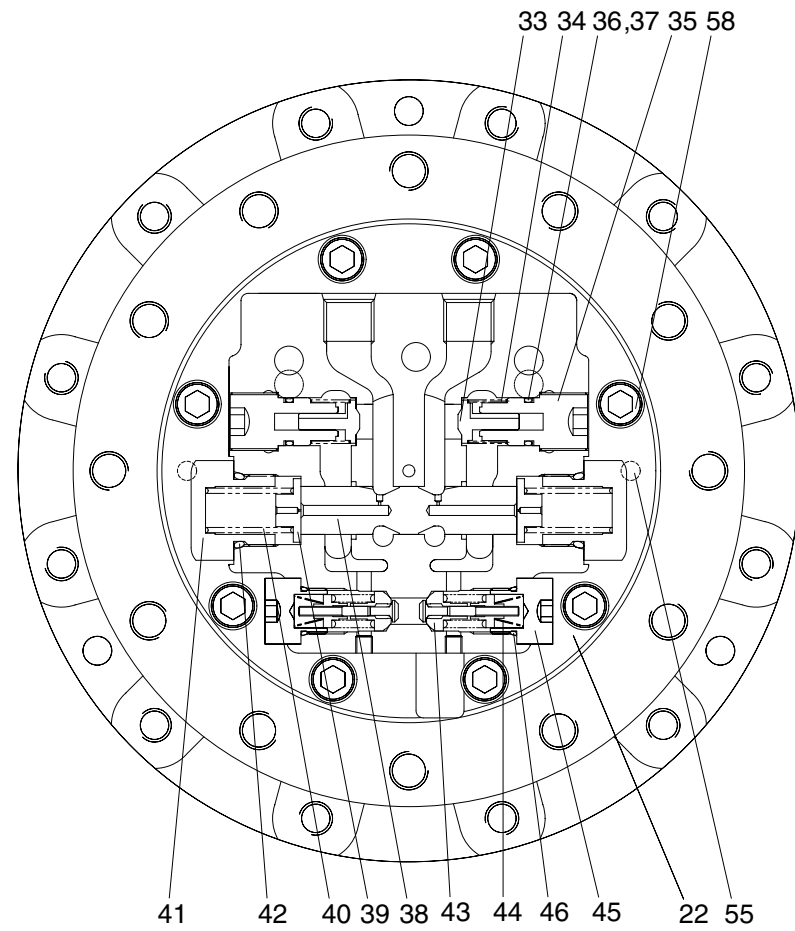

1 Shaft casing	16 Parking plate	31 O-ring	45 Plug	59 Ring gear	73 Carrier
2 Oil seal	17 Parking piston	32 Snap ring	46 O-ring	60 Angular bearing	74 Spring pin
3 Shaft	18 O-ring	33 Check	47 Steel ball	61 Steel ball	75 Collar
4 Bearing	19 Back up ring	34 Spring	48 Check seat	62 Plug	76 Planetary gear(B)
5 Swash piston	20 O-ring	35 Plug	49 Plug	63 Floating seal	77 Needle bearing
6 Piston ring	21 Back up ring	36 O-ring	50 Plug	64 Nut	78 Drive gear
7 Swash steel ball	22 Rear cover	37 Back up ring	51 O-ring	65 Washer	79 Thrust plate
8 Swash plate	23 Plug	38 Main spool	52 Roller bearing	66 Collar	80 Ring gear cover
9 Cylinder block	24 Spool	39 Spring seat	53 O-ring	67 Planetary gear(A)	81 Plug
10 Spring	25 Spring	40 Spring	54 Hex plug	68 Needle bearing	82 O-ring
11 Ball guide	26 Stopper	41 Plug	55 Parallel pin	69 Plate	83 Wrench bolt
12 Set plate	27 Snap ring	42 O-ring	56 Spring	70 Bolt	84 Name plate
13 Valve plate	28 Check	43 Relief valve assembly	57 O-ring	71 Sun gear	85 Rivet
14 Piston assembly	29 Spring	44 Spring	58 Wrench bolt	72 Snap ring	86 Seal kit
15 Friction plate	30 Seat				

7072TM02

2) TOOLS AND TIGHTENING TORQUE

(1) Tools

Name of tools	Size	Name of applied parts
Hexagonal L-wrench	4	Plug(23)
	6	Plug(49), wrench bolt(70, 83)
	8	Plug(81)
	-	Relief valve assembly(46)
	-	Plug(38, 52, 50)
Socket wrench / spanner	27	Plug(41)
Snap-ring plier(for holes, axis)		Snap ring(27, 32, 72)
Solder hammer		Bearing(4), Pin(55, 74), Oil seal(2)
Torque wrench		Size : 500, 3000
Jig for assembling oil seal		Oil seal(2)
Induction heating apparatus for bearing		Bearing(4)

(2) Tightening torque

No.	Name	Size	Torque	
			kgf · m	lbf · ft
23	Plug	NPT 1/16	0.7~1.1	5.1~7.9
49	Plug	PT 1/4	5	36.2
81	Plug	PT 3/8	8.5	61.5
58	Wrench bolt	M12×35L	10	72.3
70, 83	Wrench bolt	M8×20L	10	72.3

3. DISASSEMBLY

1) GENERAL PRECAUTIONS

- (1) Select a clean place for disassembling.
Spread a rubber plate on a working table in order to prohibit the damage of parts.
- (2) Clean a deceleration equipment and a motor part, washing out dirt and unnecessary substances.
- (3) Without any damage of O-ring, oil seal, the adhered surface of other seals, a gear, a pin, the adhered surface of other bearings, and the surface of moisturized copper, treat each parts.
- (4) Numbers written in the parenthesis, (), next to the name of a part represent the part numbers of a previous page.
- (5) The side of a pipe in a motor can be written as a rear side ; the side of out-put as a front side.
- (6) In case of bonding bolts, combine a standard torque by torque wrench after spraying loctite 262 on the tab parts. (It can be dealt as assembling NPTF screws and an acceleration equipment.)

2) DISASSEMBLING

(1) Motor unit

- ① Put the motor assembly on the assemble table.
Using L-Wrench, disassemble wrench bolt(58)-8EA and so respectively disassemble shaft casing assembly and rear cover assembly.

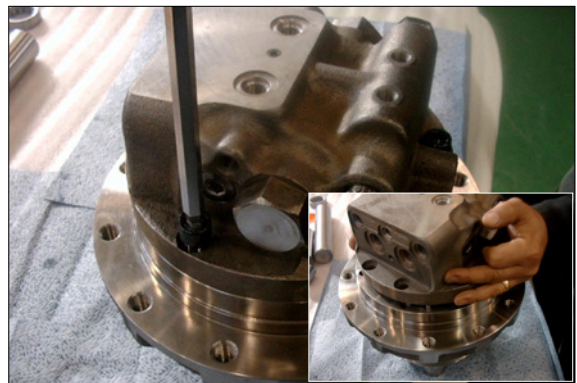

7078TM01/01A

- ② Disassemble spring(56)-8EA From shaft casing(1).

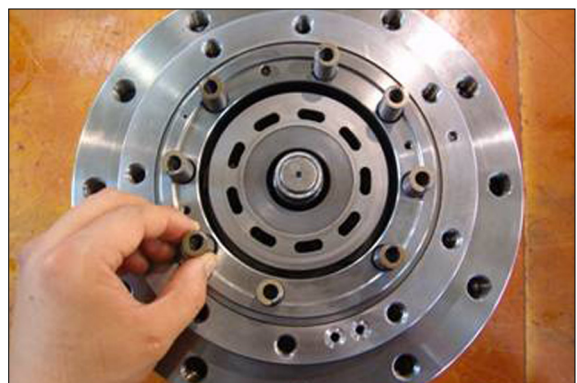

7078TM02

- ③ Using jig, disassemble parking piston(17) from shaft casing(1).



7078TM03

- ④ Disassemble O-ring(18, 20) and back up ring(19, 21) from parking piston(17)



7078TM04/04A

- ⑤ Respectively in order friction plate (15), parking plate(16) disassemble from shaft casing(1).

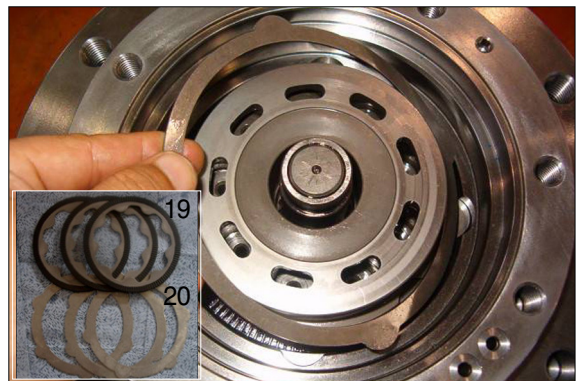

7078TM05/05A

- ⑥ Disassemble cylinder block assembly(9) from shaft casing(1).



7078TM06

(2) Cylinder block

- ① Disassemble set plate(12), piston assembly(14) from cylinder block assembly.

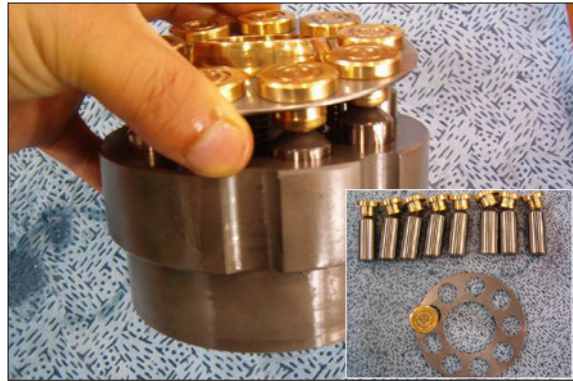

7078TM07/07A

- ② Disassembling in order cylinder block(9), ball guide(11) and spring(10).

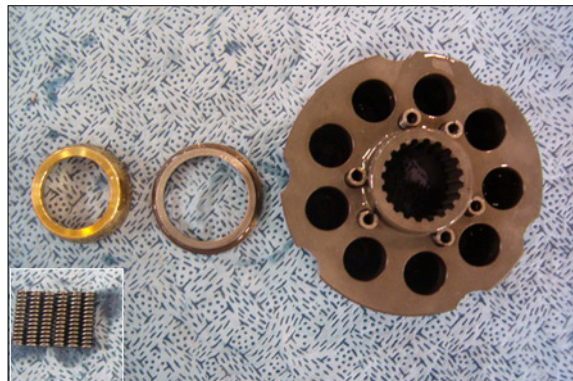

7078TM08/08A

- ③ Disassembling swash plate(8) and shaft(3) from shaft casing(1).

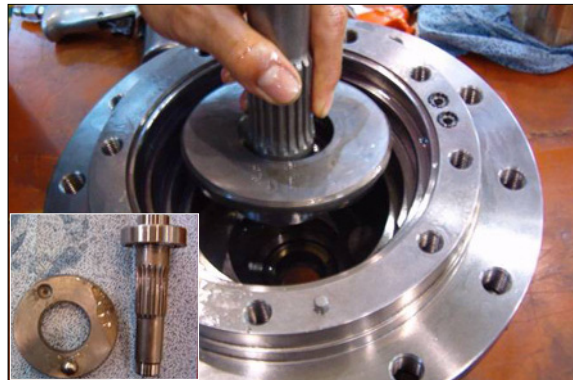

7078TM09/09A

- ④ Disassembling swash piston(5) from shaft casing(1).

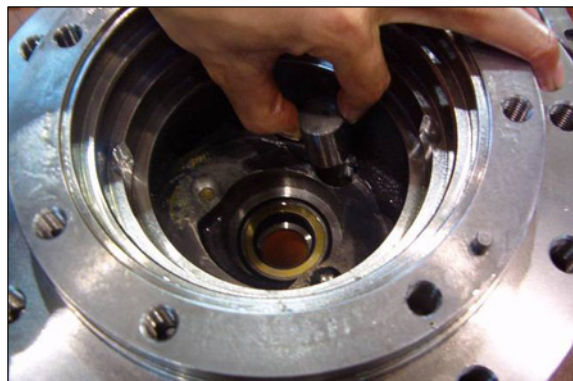

7078TM10

- ⑤ Disassembling steel ball(7) from shaft casing(1).

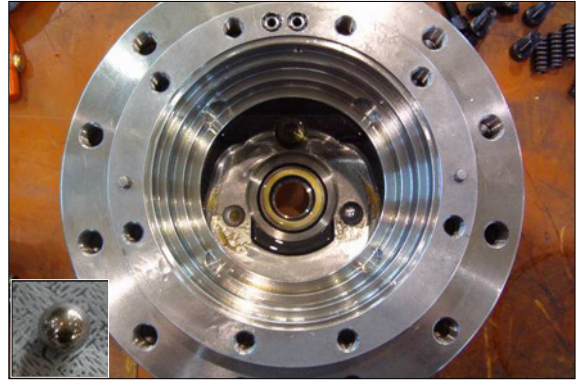

7078TM11/11A

(3) Rear cover

- ① Disassembling valve plate(13) from rear cover(22).

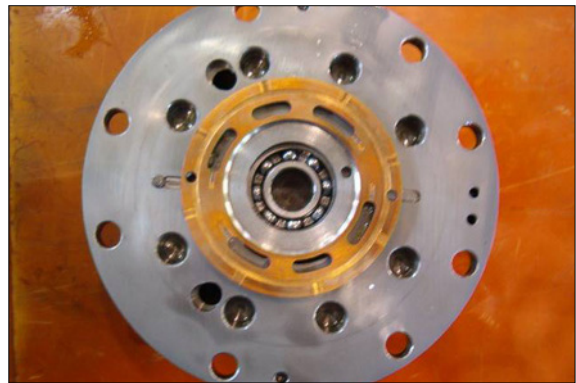

7078TM12

- ② Using plier jig, disassembling in order snap ring(27), stopper(26), spring(25), spool(24) from rear cover(22) and then disassembling snap ring(32), seat(30), spring(29), check(28) same procedure.

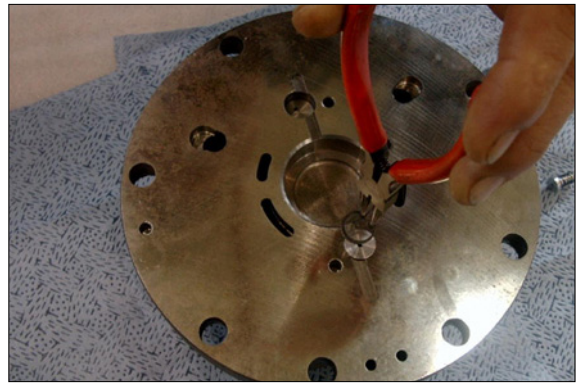

7078TM13

- ③ Using L-wrench, disassembling plug(45) from rear cover(22) and then relief valve assembly(43) (left, right is symmetry).



7078TM14/14A

- ④ Using torque wrench, disassembling plug (41) in order O-ring(42), spring(40), spring seat(39), main spool(38) from rear cover(22).

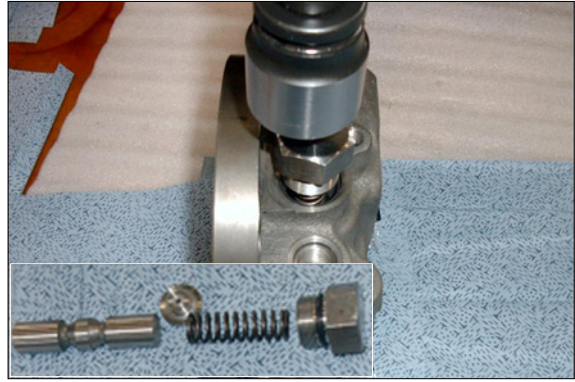

7078TM15/15A

- ⑤ Using L-wrench, disassembling plug(35) in order O-ring(36), back up ring(37), spring(34) and check(32) from rear cover(22).



7078TM16/16A

(4) Reduction gear

- ① Using L-wrench, disassembling wrench bolt(83) and then ring gear cover(80), O-ring(82) from ring gear(59).



7078TM17/17A

- ② Disassembling thrust plate(79) from ring gear(59).



7078TM18/18A

- ③ Disassembling in order planetary gear(76), drive gear(78) from ring gear(59).

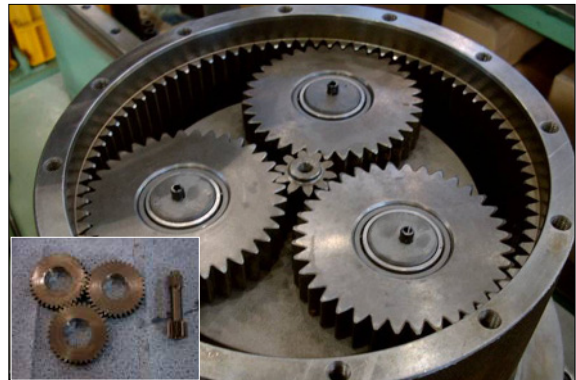

7078TM19/19A

- ④ Disassembling needle bearing(77) from ring gear(59).

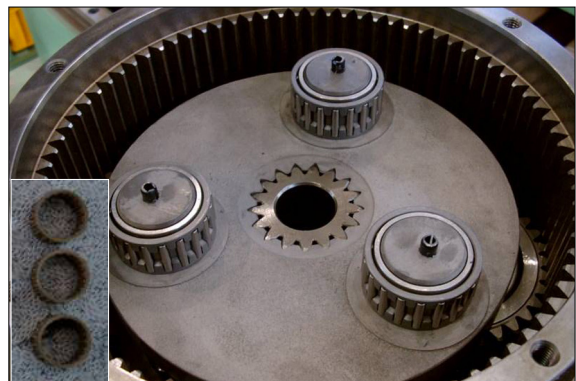

7078TM20/20A

- ⑤ Disassembling in order collar(75), carrier(73) from ring gear(59).

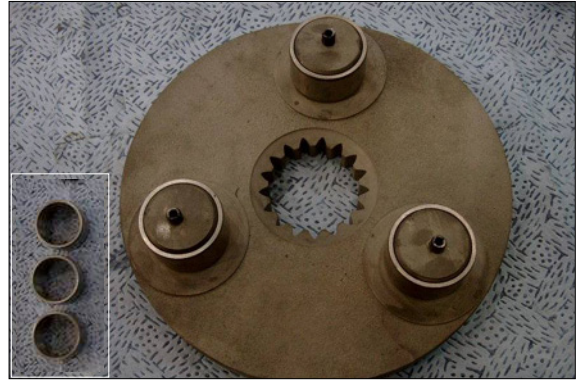

7078TM21/21A

- ⑥ Disassembling sun gear(71) from ring gear(59) and then disassembling snap ring(72) with plier jig.

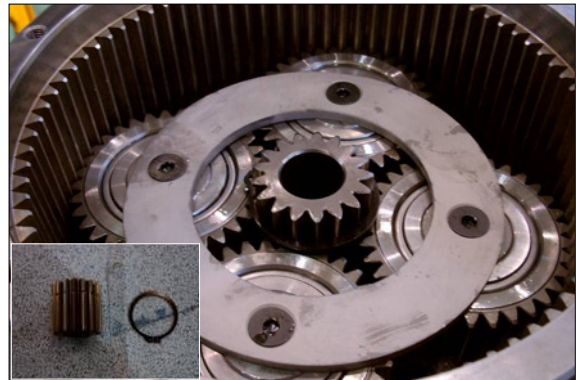

7078TM22/22A

- ⑦ Using L-wrench, disassembling plate head bolt(70)-4EA from ring gear(59) and then disassembling plate(69).

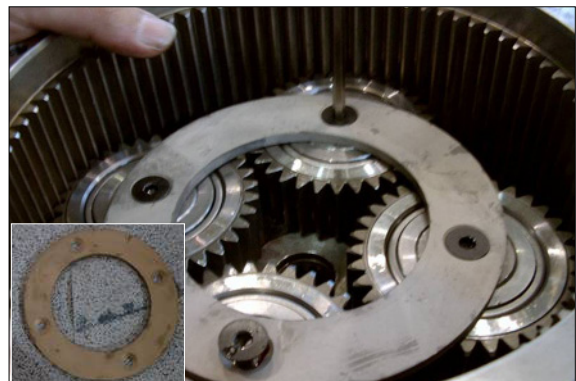

7078TM23/23A

- ⑧ Disassembling planetary gear(67)-4EA from ring gear(59).

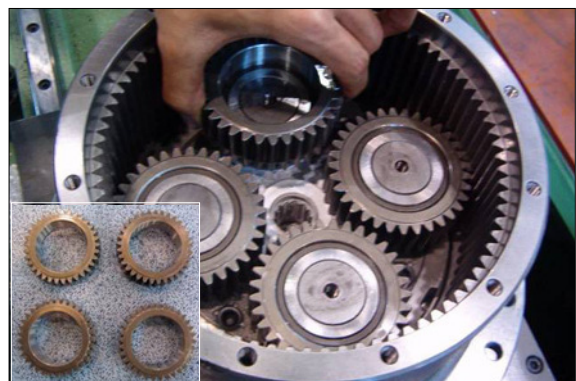

7078TM24/24A

- ⑨ Disassembling needle bearing(68)-4EA from ring gear(59).

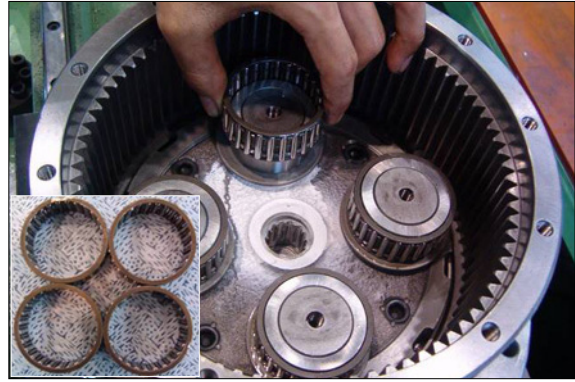

7078TM25/25A

- ⑩ Disassembling collar(66)-4EA from ring gear(59).

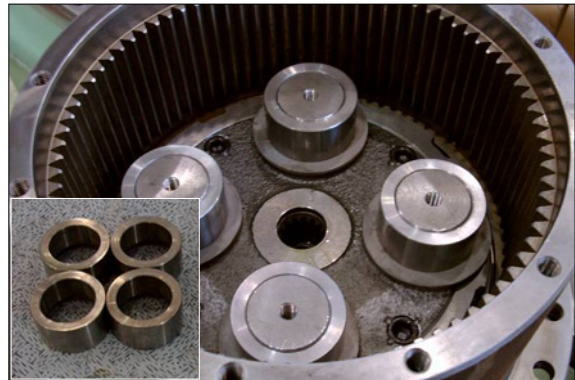

7078TM26/26A

- ⑪ Disassembling washer(65)-4EA from ring gear(59).

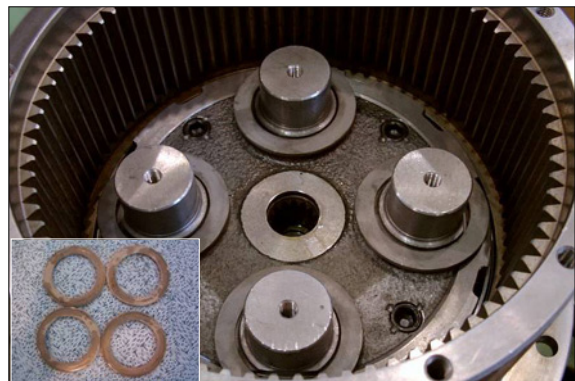

7078TM27/27A

- ⑫ Using jig, disassembling nut(64) when inner pressed state with L-wrench bolt from ring gear(59).

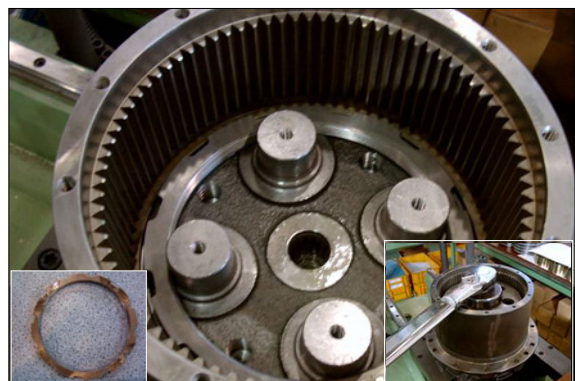

7078TM28/28A/B

- ⑬ Put the reduction gear on the assembling jig and then disassembling ring gear(59).

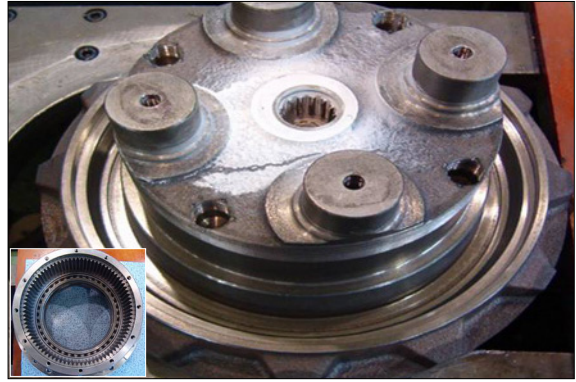

4. ASSEMBLY

1) GENERAL SUGGESTIONS

- (1) After washing each parts cleanly, dry it with compressed air.
Provided that you do not wash friction plate with treated oil.
- (2) In bonding each part, fasten bond torque.
- (3) When using a hammer, do not forget to use a plastic hammer.

2) ASSEMBLING

(1) Sub of turning axis

- ① Using a jig, insert the steel ball(61) to the shaft casing(1) and then assemble plug(62).

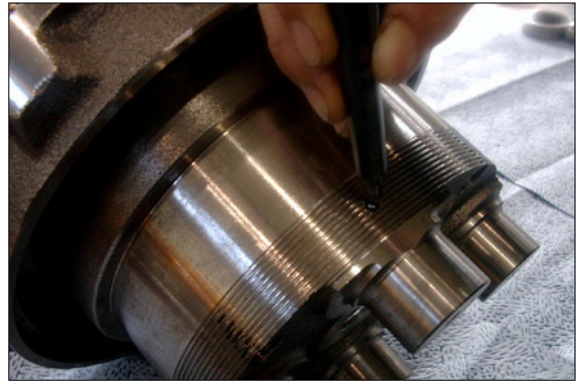

7078TM51

- ② Using a jig, assemble oil seal(2) to the shaft casing(1) and then inserting with solid hammer.

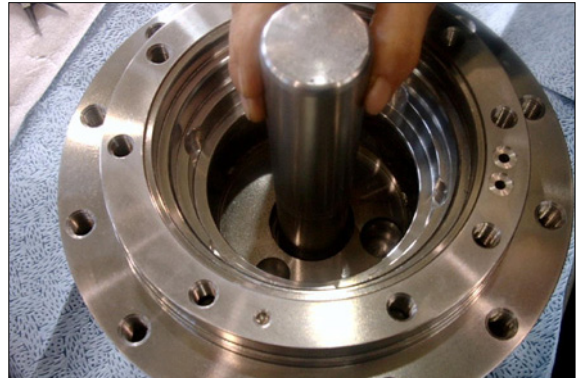

7078TM52

- ③ Assemble swash steel ball(7) to the shaft casing(1) with grease.

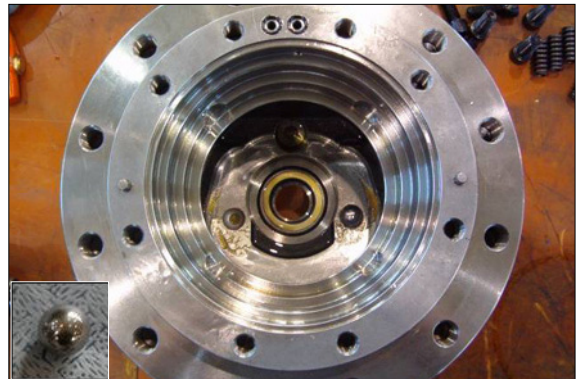

7078TM53/11A

- ④ Assemble swash piston(5) to the shaft casing(1).

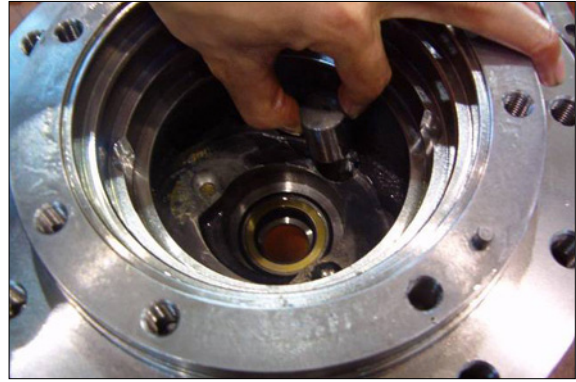

- ⑤ Heat pressing bearing to the shaft(3).

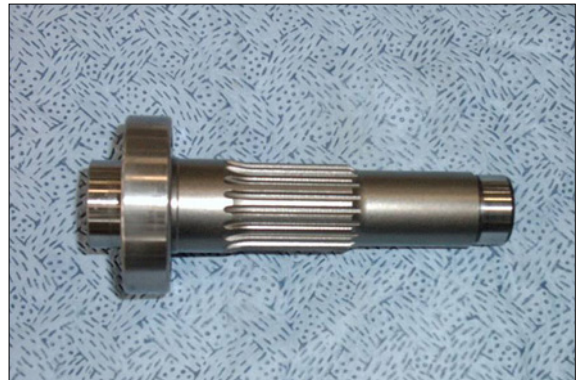

- ⑥ Assemble bearing and heat pressed shaft(3) to the shaft casing(1).



(2) Cylinder block sub assembly

- ① Assemble piston assembly(14) to the set plate(12, 9 set).



- ② Assemble spring(10) to the cylinder block(9, 6 set).



7078TM58

- ③ Assemble ball guide(11) to the cylinder block(9).

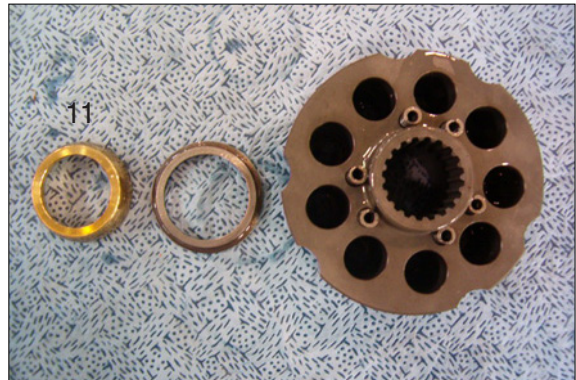

7078TM08/08A

- ④ Assemble sub-assembled piston(12,14) to the cylinder block(9).



7078TM60

- ⑤ Assemble cylinder block(10) to the shaft casing(1).



7078TM06

- ⑥ Assembling friction plate(15), parking plate(16)(respectively 3EA assembling) to the shaft casing(1).

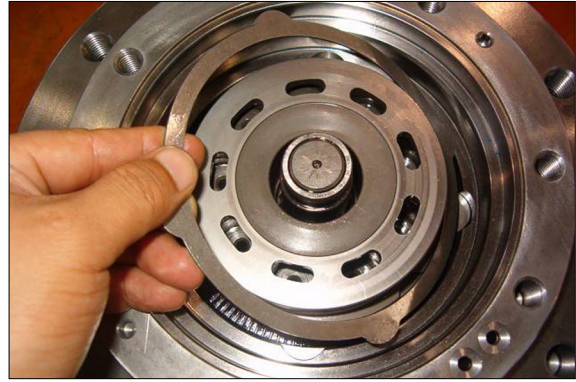

7078TM05

- ⑦ Assembling back up ring(19), O-ring(18, 20), back up ring(21) to the parking piston(17).

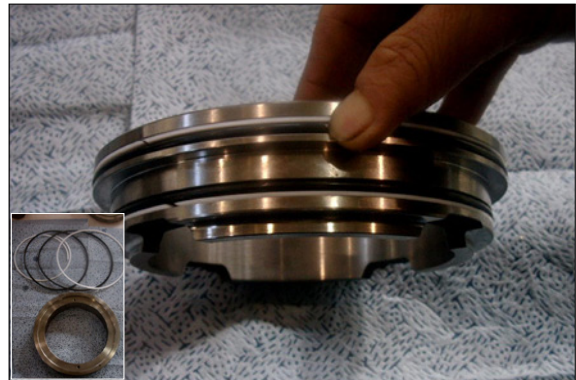

7078TM04/04A

- ⑧ Using a jig, insert the parking piston to the shaft casing(1) and assemble.



7078TM64/64A

- ⑨ Assemble spring(56) to the shaft casing(1) and then assemble O-ring(57).

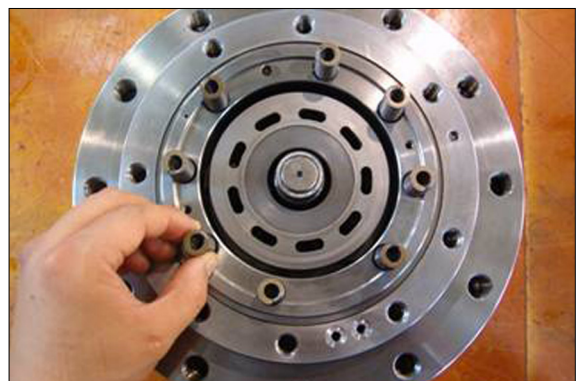

7078TM02

(3) Rear cover assembly

- ① Using a L-Wrench, assemble plug(23) 10EA to the rear cover(22).



7078TM66

- ② Assemble in order steel ball(47), check-seat(48) and plug(49) to the rear cover (22).

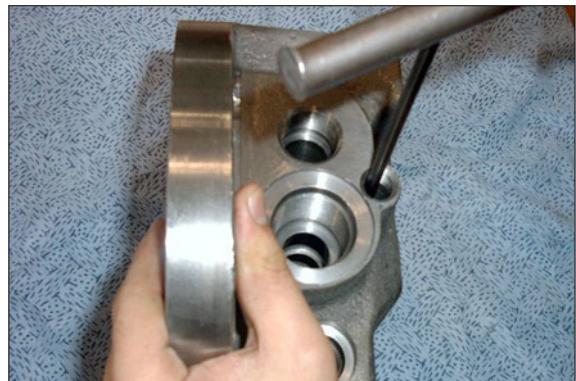

7078TM67

- ③ Assemble plug(50, 52), O-ring(51, 53) to the rear cover(22).

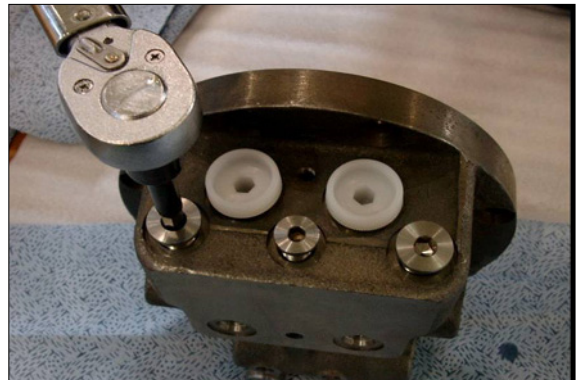

7078TM68

- ④ Assemble check(33), spring(34) to rear cover(22) and assemble back up ring(37), O-ring(36) to the plug(35) after then using L-Wrench.

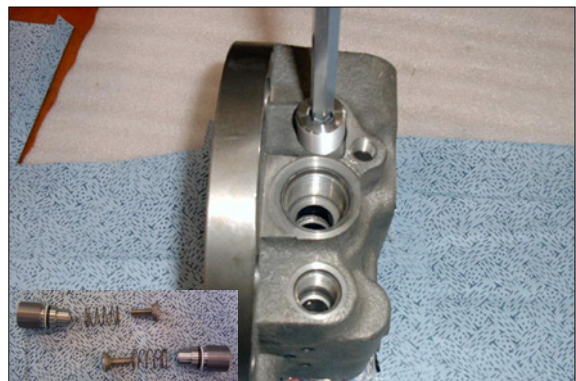

7078TM16/16A

- ⑤ Insert main spool(38), spring-seat(39), spring(40) to the rear cover(22) and assemble plug(41) with L-wrench.



7078TM15/15A

- ⑥ Assemble relief valve assembly(43)(with left-right symmetry) to the rear cover(22) and then insert spring(44) and assemble plug(45) with torque-wrench.



7078TM71/14A

- ⑦ Using a plier jig, assemble snap ring(27), stopper(26), spring(25), spool(24) to the rear cover.
Same method assemble snap ring(32), seat(30), spring(29) and check(28).

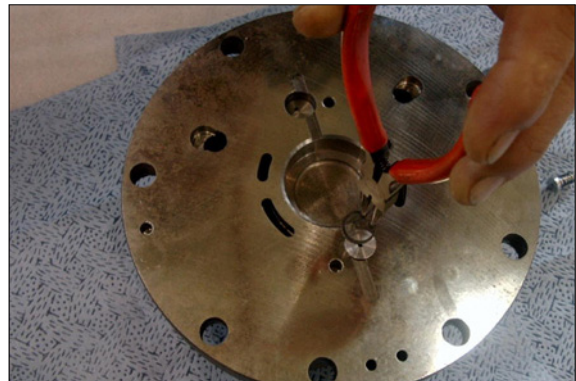

7078TM13

- ⑧ Assemble roller bearing(54), pin(55) and valve plate(56) to the rear cover(22).

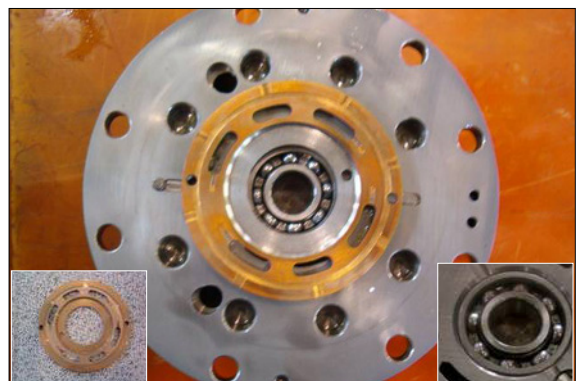

7078TM12/73/73A

- ⑨ Combine rear cover assembly and shaft casing assembly with bolt(58).

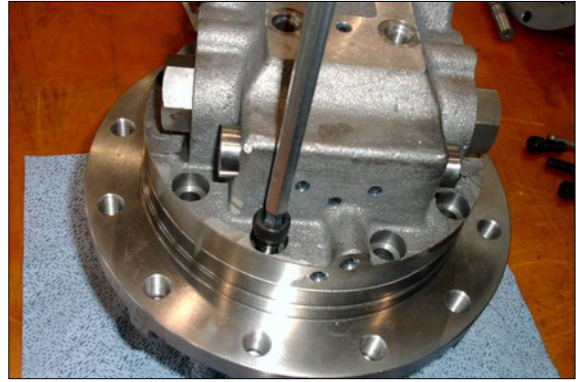

7078TM74

(4) Travel reduction gear

- ① Before assembling nut(64) to the motor.
Eliminate burr and alien substances
ready for assembling.



7078TM77/28A

- ② Insert ring gear(59) to the spray washing
M/C and heat 69°C~70°C one minute.



7078TM78

- ③ Assembling angular bearing(60) to the
ring gear(59).



7078TM79/79A

- ④ Insert steel ball(61) 105EA to the ring gear(59) with a jig after assembling plug(62) 2EA with L-Wrench.



7078TM80/80A

- ⑤ Assemble floating seal(63) to ring gear(59) and motor part with a jig.



7078TM81/81A/82

- ⑥ Upset the ring gear(59) and assemble with motor.

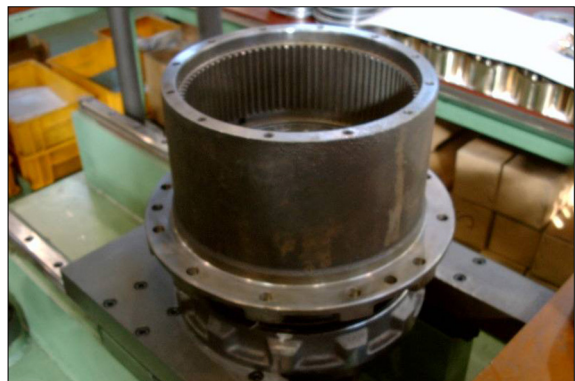

7078TM83

- ⑦ Combine nut(64) to the ring gear(59) and pressing use a jig and then assembling with torque-wrench.



7078TM28/28B/28C

- ⑧ Using a L-wrench, assembling plug-4EA to the ring gear(59) and then cocking by a jig.

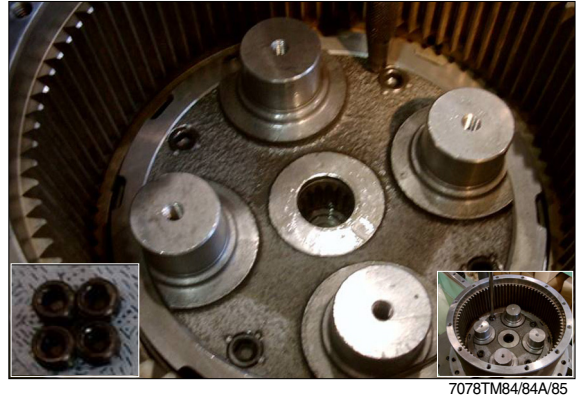

- ⑨ Assemble washer(65)-4EA the ring gear(59).

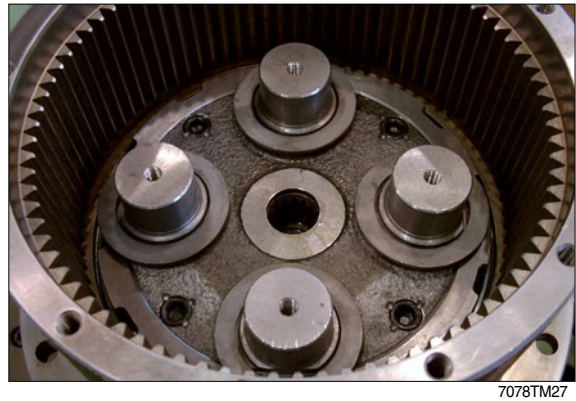

- ⑩ Assemble collar(66)-4EA to the ring gear(59).

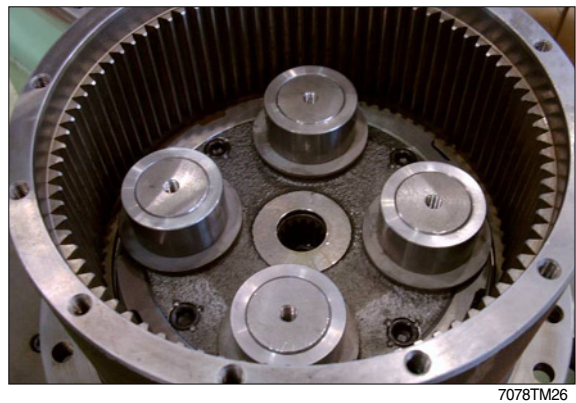

- ⑪ Assemble needle bearing(68)-4EA to the ring gear(59).

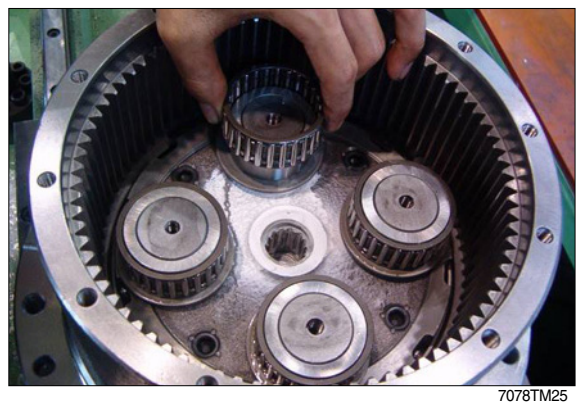

- ⑫ Assemble planetary gear(67)-4EA to the ring gear(59).



7078TM24

- ⑬ Assemble plate(69)-1EA to the ring gear(59) and then combine plate head bolt(70)-4EA with L-wrench. (after paste loctite and then combine the plate head bolt).

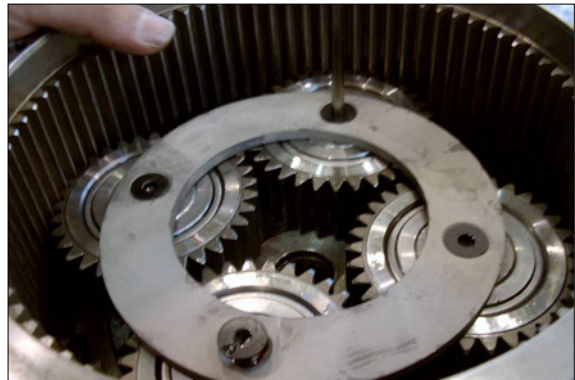

7078TM23

- ⑭ Assembling snap ring(72) to the sun gear(71) with a plier jig.

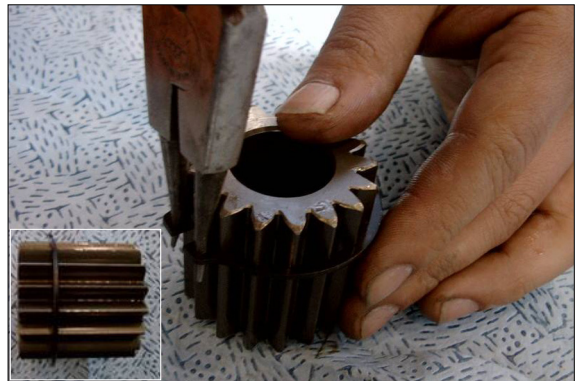

7078TM86/86A

- ⑮ Assemble sun gear with snap ring assembly to the ring gear(59).

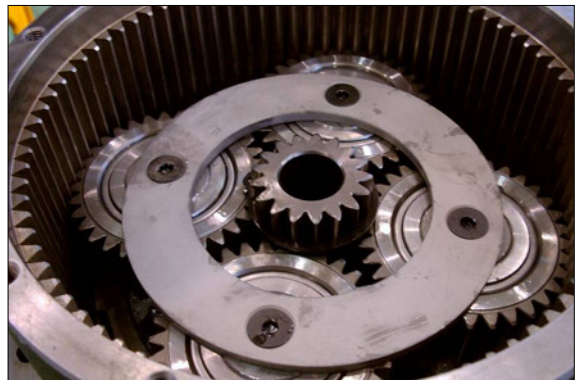

7078TM22

§ Assemble in order collar(75), spring pin(74) to the carrier(73).



7078TM21

§ Assemble carrier sub assembly to the ring gear(59).

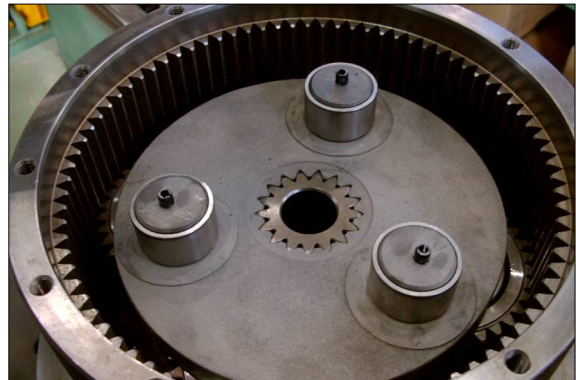

7078TM87

§ Assemble needle bearing(77)-3EA to the ring gear(59).

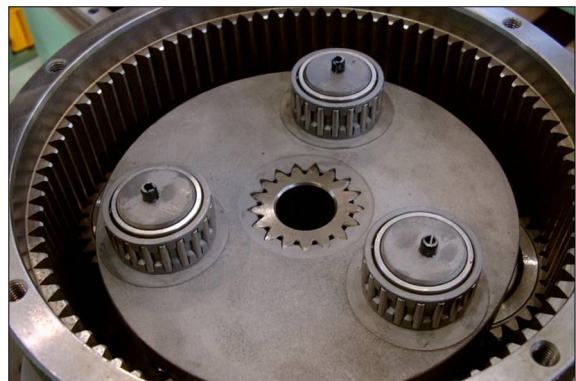

7078TM20

§ Assemble in order planetary gear(76), drive gear(78) to the ring gear(59).

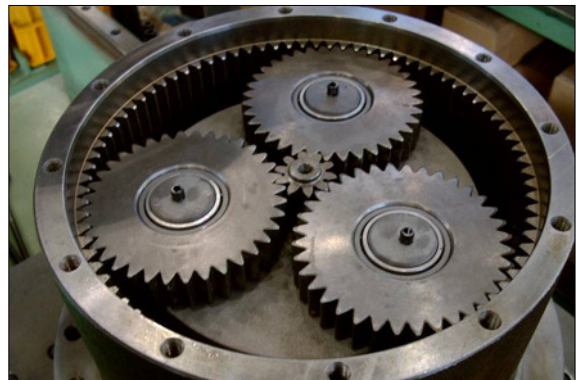

7078TM19

§ Assemble thrust plate(79) to the ring gear(59).

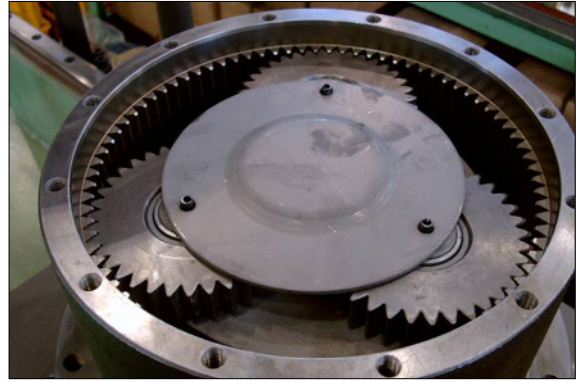

7078TM18

§₁ Assemble in order ring gear cover(80) with O-ring(82) and then assemble wrench bolt(83) with torque-wrench.



7078TM17/17A

§ Roll the tarpon tape to the ring gear(59) and then combine with L-wrench(after test of drain part water pressure and capacity and then assemble plug PT3/8 form).



7078TM88

(5) Test

① Motor water pressure test

-Check the oil leak for one minute by appearance test at air pressure 5kgf/cm².



7078TM89

② Performance test

-Pour the gear oil(80W-90) by beaker at the reduction gear.



7078TM90

③ Test bench mounting

-Partially performance test by mounting motor test bench.

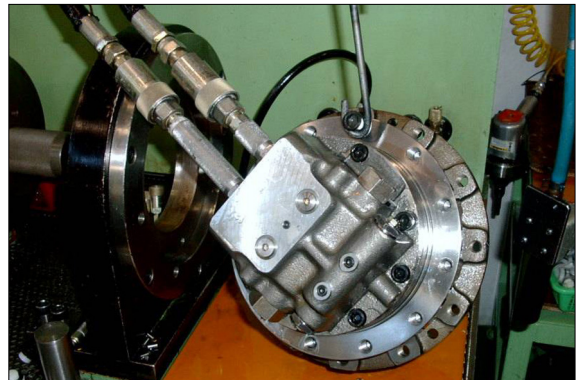

7078TM91