

## GROUP 4 MAIN CONTROL VALVE

### 1. REMOVAL AND INSTALL OF MOTOR

#### 1) REMOVAL

- (1) Lower the work equipment to the ground and stop the engine.
- (2) Operate the control levers and pedals several times to release the remaining pressure in the hydraulic piping.
- (3) Loosen the breather slowly to release the pressure inside the hydraulic tank.

**▲ Escaping fluid under pressure can penetrate the skin causing serious injury.**

※ When pipes and hoses are disconnected, the oil inside the piping will flow out, so catch it in oil pan.

- (4) Remove bolts and disconnect pipe.
- (5) Disconnect pilot line hoses.
- (6) Disconnect pilot piping.
- (7) Sling the control valve assembly and remove the control valve mounting bolt.  
· Weight : 60kg(130lb)
- (8) Remove the control valve assembly.  
When removing the control valve assembly, check that all the piping have been disconnected.

#### 2) INSTALL

- (1) Carry out installation in the reverse order to removal.
- (2) Bleed the air from below items.
  - ① Cylinder(Boom, arm, bucket)
  - ② Swing motor
  - ③ Travel motor※ See each item removal and install.
- (3) Confirm the hydraulic oil level and recheck the hydraulic oil leak or not.

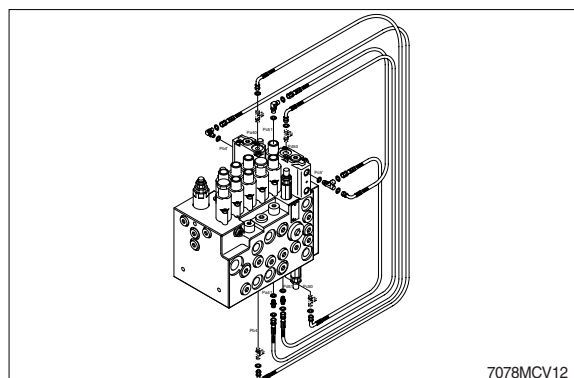
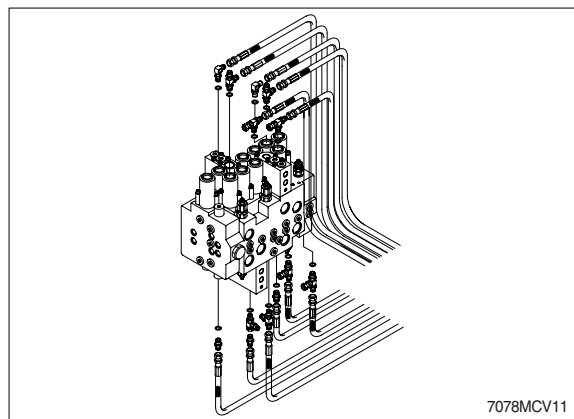
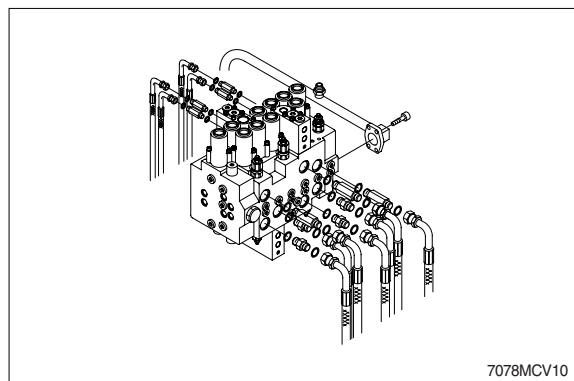

## 2. STRUCTURE(1/4)

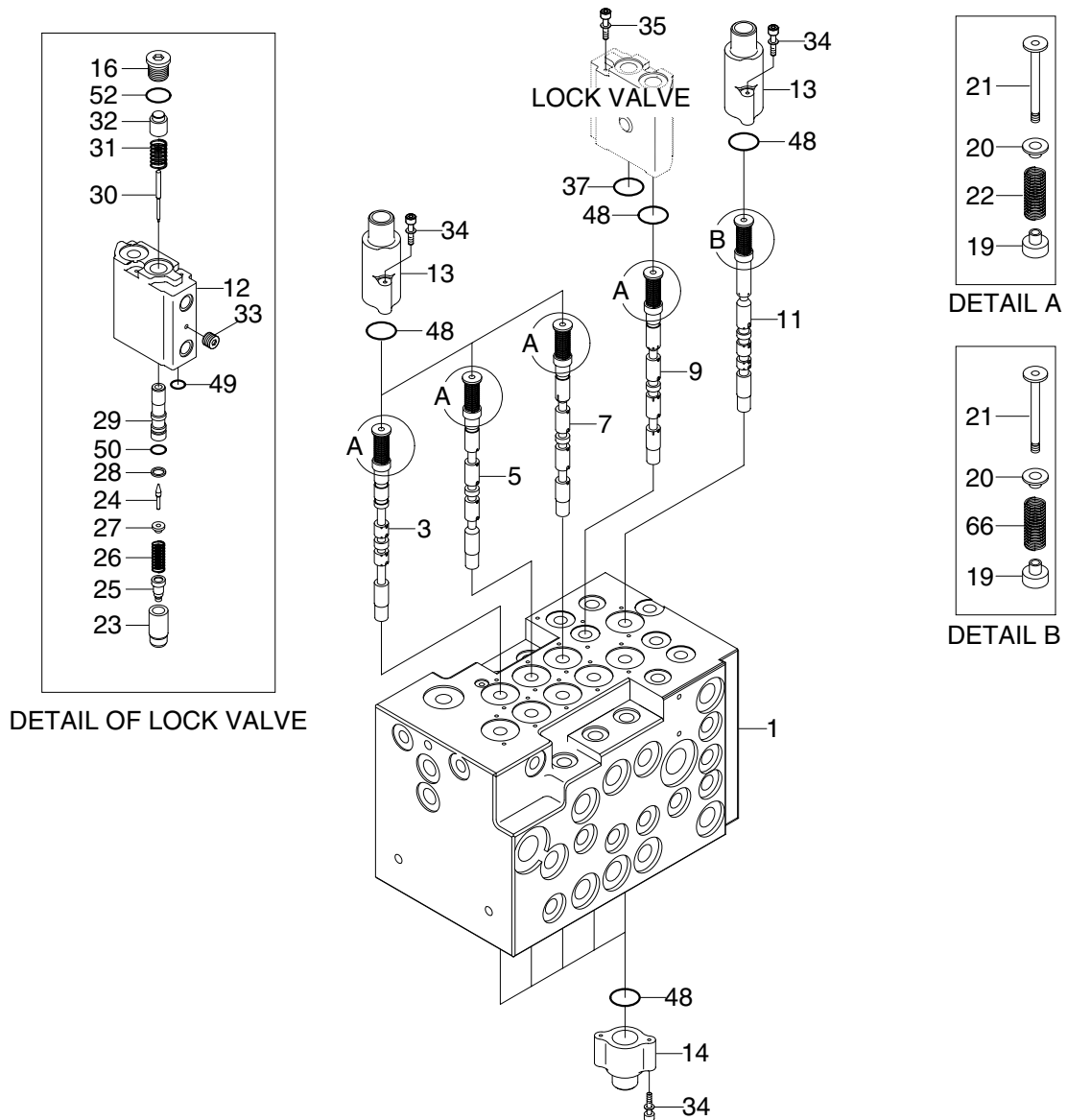

DETAIL OF LOCK VALVE

DETAIL A

DETAIL B

- |    |                  |    |                       |    |                   |
|----|------------------|----|-----------------------|----|-------------------|
| 1  | Body             | 20 | Spring holder         | 31 | Lock valve spring |
| 3  | Spool-Travel(LH) | 21 | Spool end             | 32 | Piston            |
| 5  | Spool-Swing      | 22 | Spring                | 33 | Plug              |
| 7  | Spool-Option     | 23 | Lock valve            | 34 | Socket head bolt  |
| 9  | Spool-Boom 2     | 24 | Poppet                | 35 | Socket head bolt  |
| 11 | Spool-Arm        | 25 | Lock valve restrictor | 37 | O-ring            |
| 12 | Pilot-Cover      | 26 | Lock valve spring     | 48 | O-ring            |
| 13 | Pilot-Cover      | 27 | Spring holder         | 49 | O-ring            |
| 14 | Pilot-Cover      | 28 | Retaining ring        | 50 | O-ring            |
| 16 | Plug             | 29 | Piston guide          | 52 | O-ring            |
| 19 | Spring holder    | 30 | Piston                | 66 | Spring            |

7072MCV31

# STRUCTURE(2/4)

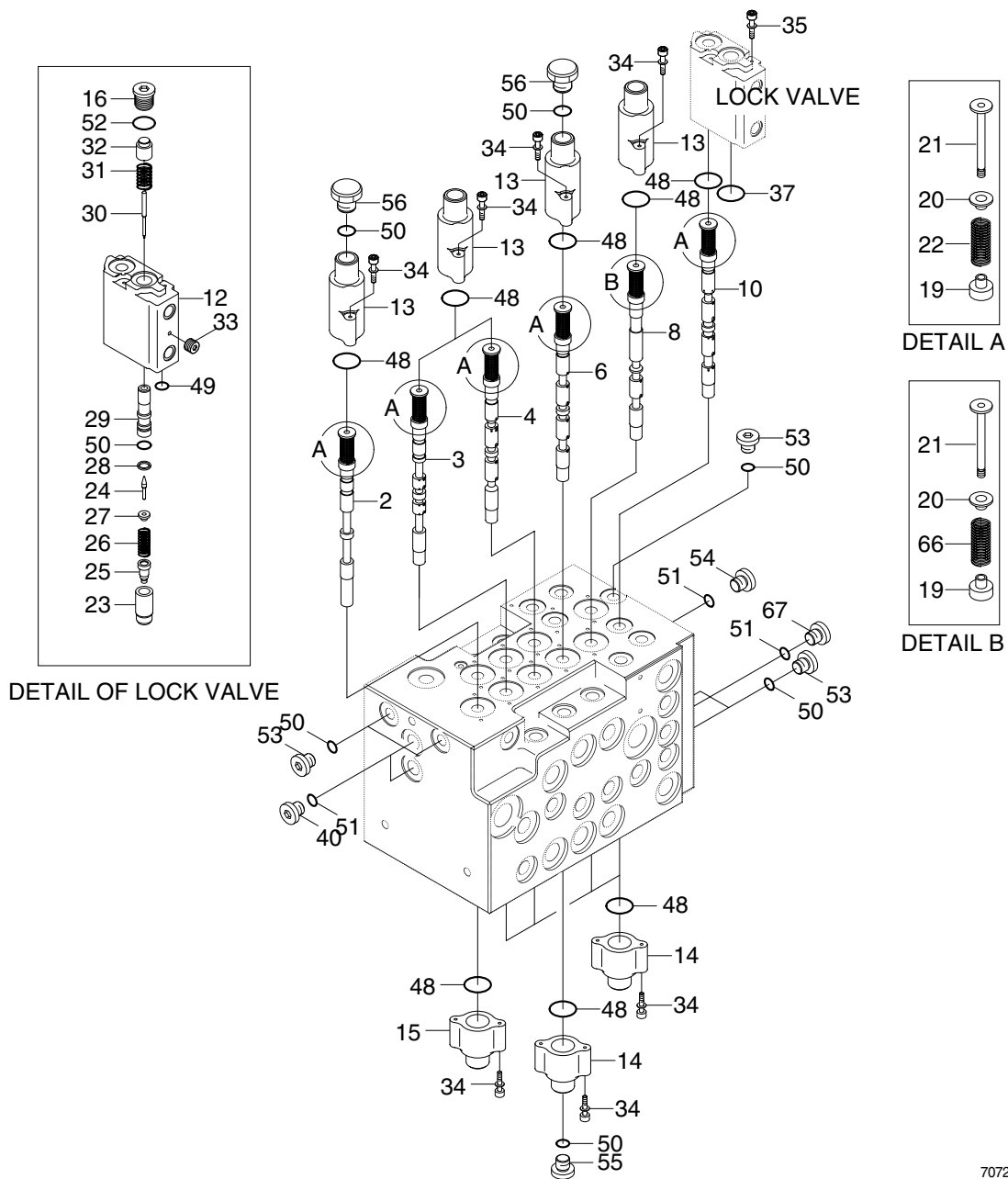

- 2 Spool-Travel straight
- 4 Spool-Travel(RH)
- 6 Spool-Dozer
- 8 Spool-Boom
- 10 Spool-Arm 2
- 12 Pilot-Cover
- 13 Pilot-Cover
- 14 Pilot-Cover
- 15 Pilot-Cover
- 16 Plug
- 19 Spring holder
- 20 Spring holder
- 21 Spool end
- 22 Spring

- 23 Lock valve
- 24 Poppet
- 25 Lock valve restrictor
- 26 Lock valve spring
- 27 Spring holder
- 28 Retaining ring
- 29 Piston guide
- 30 Piston
- 31 Lock valve spring
- 32 Piston
- 33 Plug
- 34 Socket head bolt
- 35 Socket head bolt
- 37 O-ring

- 40 Plug
- 48 O-ring
- 49 O-ring
- 50 O-ring
- 51 O-ring
- 52 O-ring
- 53 Plug
- 54 Restrictor plug
- 55 Plug
- 56 Plug
- 66 Spring
- 67 Restrictor plug

7072MCV32

# STRUCTURE(3/4)

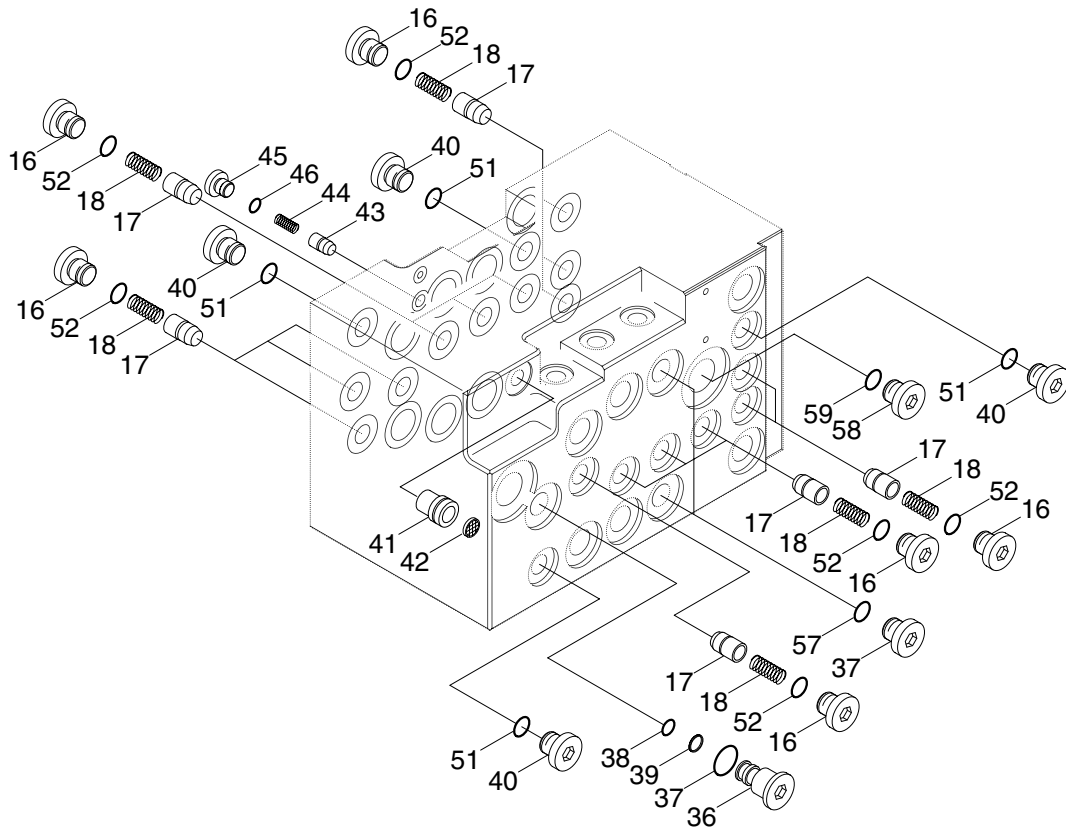

7072MCV33

- |                       |                       |           |
|-----------------------|-----------------------|-----------|
| 16 Plug               | 40 Plug               | 51 O-ring |
| 17 Check valve        | 41 Restrictor plug    | 52 O-ring |
| 18 Check valve spring | 42 Coin type filter   | 57 Plug   |
| 36 Plug               | 43 Check valve        | 58 Plug   |
| 37 O-ring             | 44 Check valve spring | 59 O-ring |
| 38 O-ring             | 45 Plug               |           |
| 39 Back up ring       | 46 O-ring             |           |

## STRUCTURE(4/4)

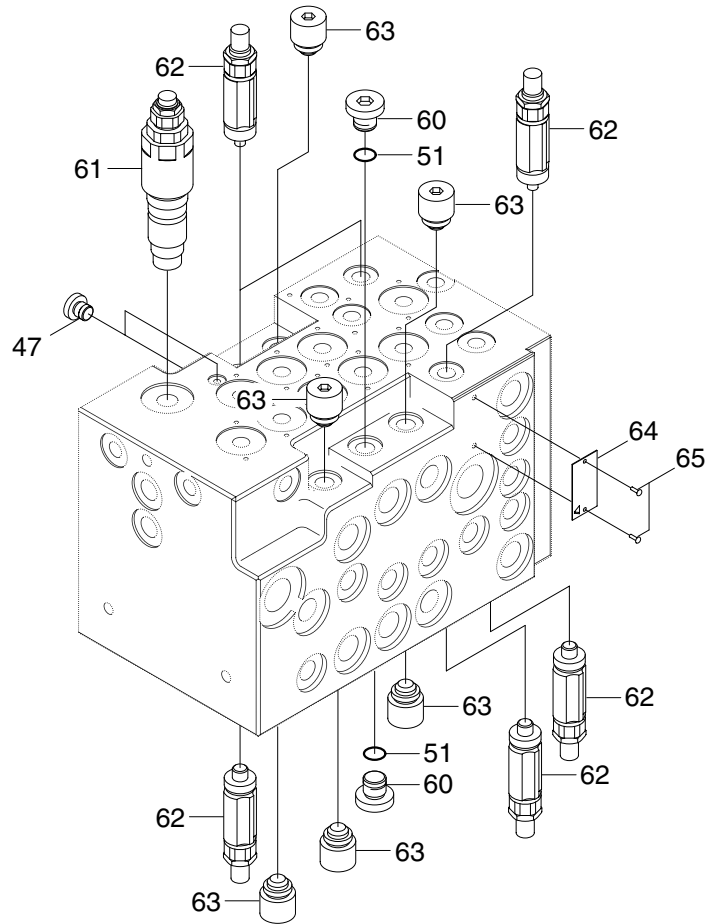

7072MCV34

- |    |                   |    |                       |
|----|-------------------|----|-----------------------|
| 47 | Plug              | 62 | Overload relief valve |
| 48 | O-ring            | 63 | Relief valve plug     |
| 51 | O-ring            | 64 | Name plate            |
| 60 | Plug              | 65 | Pin                   |
| 61 | Main relief valve |    |                       |

### 3. DISASSEMBLY AND ASSEMBLY

#### 1) GENERAL CAUTIONS

Disassembling and assembling should be executed in maker's factory in principle. And, when be obliged to do them for some unavoidable reason, they must be executed in a factory of having enough skill for hydraulic equipment with keeping following cautions.

- (1) As hydraulic equipments, not only this valve are constructed precisely with very small clearances, disassembling and assembling must be carefully done in a clean place with preventing dusts and contaminants from entering.
- (2) When removing the control valve from the machine, install caps on every ports, and wash the outside of the assembly with confirming the existence of caps before disassembling.  
Prepare a suitable table and some clean papers or rubber mat on the table for disassembling.
- (3) For carrying the control valve, never hold with spool caps portion of switching portion, and carefully treat the valves.
- (4) Do not tap the valve even if the spool movement is not smooth.
- (5) Several tests for such as relief characteristics, leakage, overload relief valve setting and flow resistance are required after re-assembling, and the hydraulic test equipments for those tests are needed.  
Therefore, do not disassemble what cannot perform test adjustment, even if it can disassemble.  
Prepare clean washing solvent, hydraulic oil and grease in advance.

#### 2) TOOLS

Prepare following tools for disassembling the control valve.

Mark	Name	Qty	Description
1	Vise	1	
2	Pads	1	
3	Allen key wrench	Each 1	4mm, 6mm, 8mm
4	Spanner	Each 1	13mm, 19mm, 22mm, 32mm
5	Socket wrench	Each 1	13mm, 19mm
6	Tweezer	1	
7	Magnet	1	
8	Plier	1	
9	Torque wrench		Suitable for each torque or adjustable one

### 3) REMOVING SPOOL

#### (1) The case of the section without lock valve

Instruction for removing the travel spool(for instance) is follows :

Remove two cap screws by 5mm allen key wrench, then remove pilot cover.

As the return spring portion of travel spool comes out, pull the spring straight slowly, by which spool assembly is removed.

Other spools(no lock valve type) can be removed in the same manner.

At this time confirm whether O-ring on the bottom of pilot cover mounting flange at body side has not fallen off.

- ※ In the case of spool replace, do not disassemble of a spool by any cases.  
Please replace by spool assembly.
- ※ Please attach using a tag etc. in the case of two or more kinds of spool replace, and understand a position.

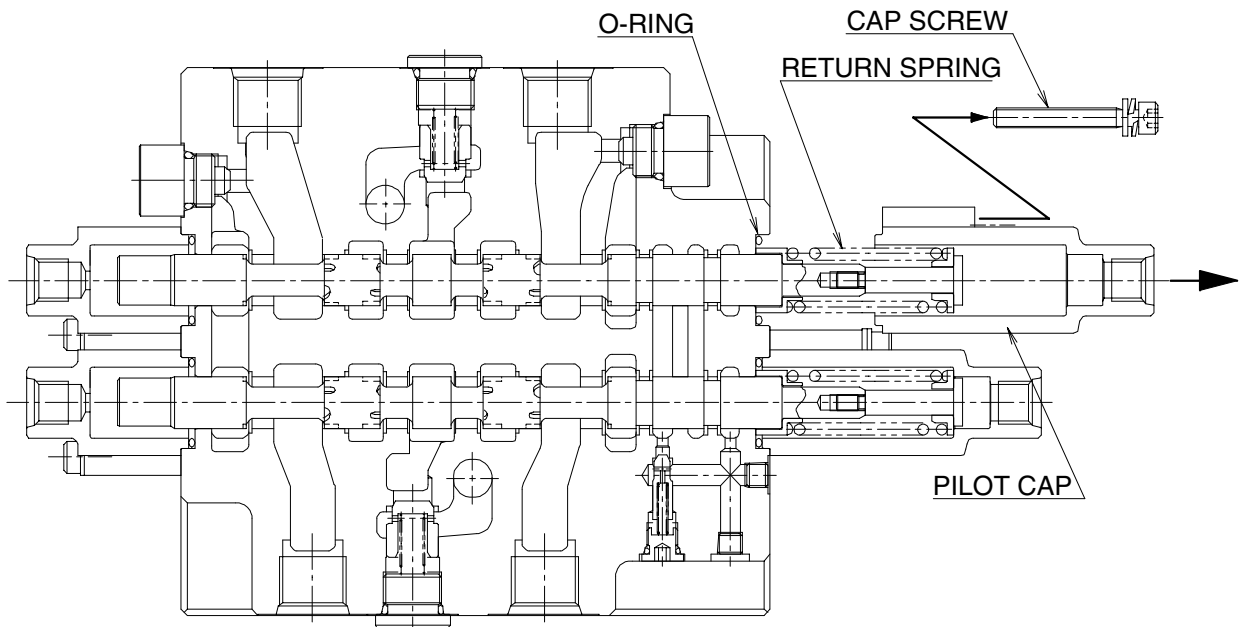

7078MCV01

## (2) The case of the section with lock valve(boom and arm)

Instruction for removing the boom spool(for instance) is follows :

Remove three cap screws by 5mm allen key wrench. Then remove pilot cover with piston guide, piston A, piston C, and spring of lock valve A.

- ※ At this time, be careful for O-ring on the bottom of pilot cover mounting flange at body side and needle valve not to separate, and remove the pilot cover.
- As the spring portion of the boom spool comes out, pull the spring straight slowly, by which spool assembly is removed.
- ※ Please treat it carefully so that a crack is not attached to the piston guide part exposed from the bottom of pilot cover.
- ※ In the case of spool replace, do not disassemble of a spool by any cases.  
Please replace by spool assembly.

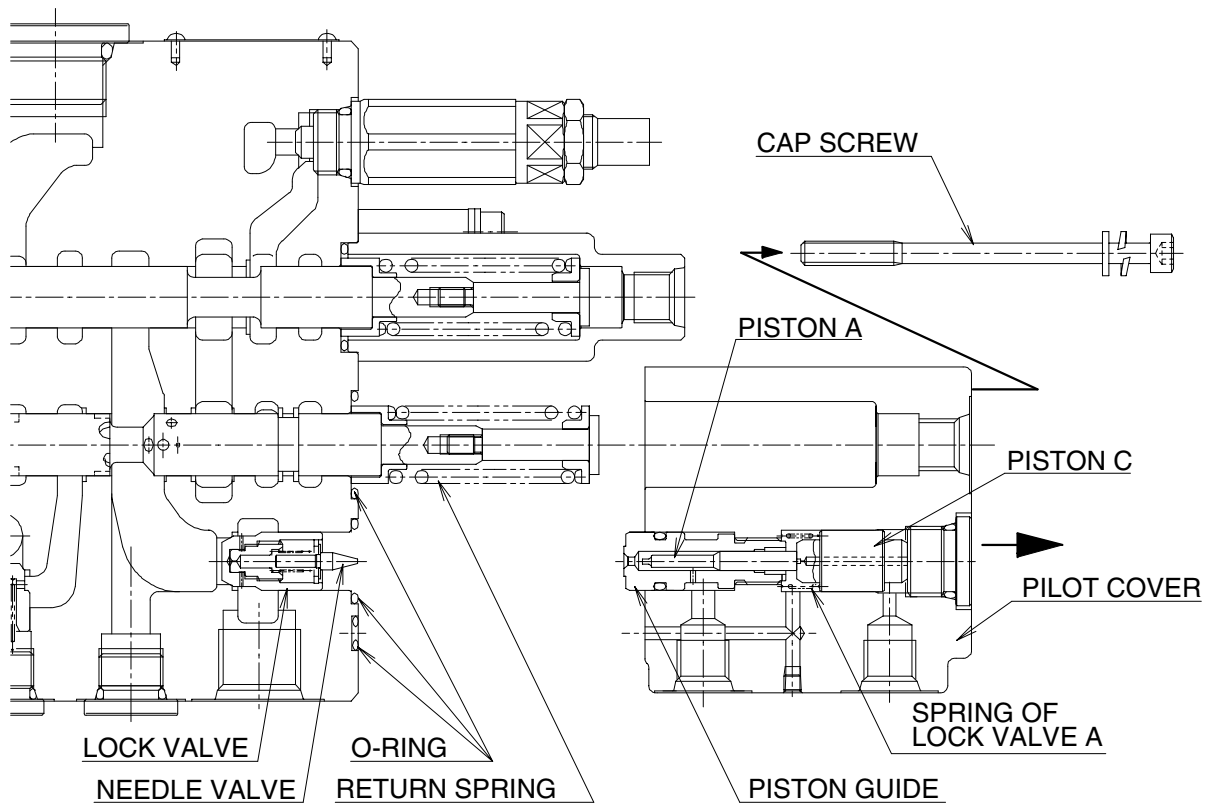

7078MCV02



#### 4) REMOVING LOCK VALVE

First, a pilot cover is removed like a previous page.

- ※ Since it is easy to separate from needle valve, please remove and keep it.
- Next, the pilot cover is fixed by vice, and the plug is loosened and removed by the 8mm allen wrench.
- ※ Please fix the sides other than a port side by vice.
- ※ Please treat it carefully so that a crack is not attached to the piston guide part exposed from the bottom of pilot cover.

From the hole which is removed the plug, piston C, spring of lock valve A, and piston A can be extracted using tweezers or a magnet.

- ※ The direction where piston C had put should be known.
- ※ Do not disassemble the piston guide. When fault arises, please replace for a pilot cover by the set.

Next, the lock valve part(lock valve, orifice of lock valve, spring of lock valve B, spring seat, retaining ring C-type) is removed from the body by the set using a magnet.

- ※ Do not disassemble the lock valve port. When fault arises, please replace by the set.

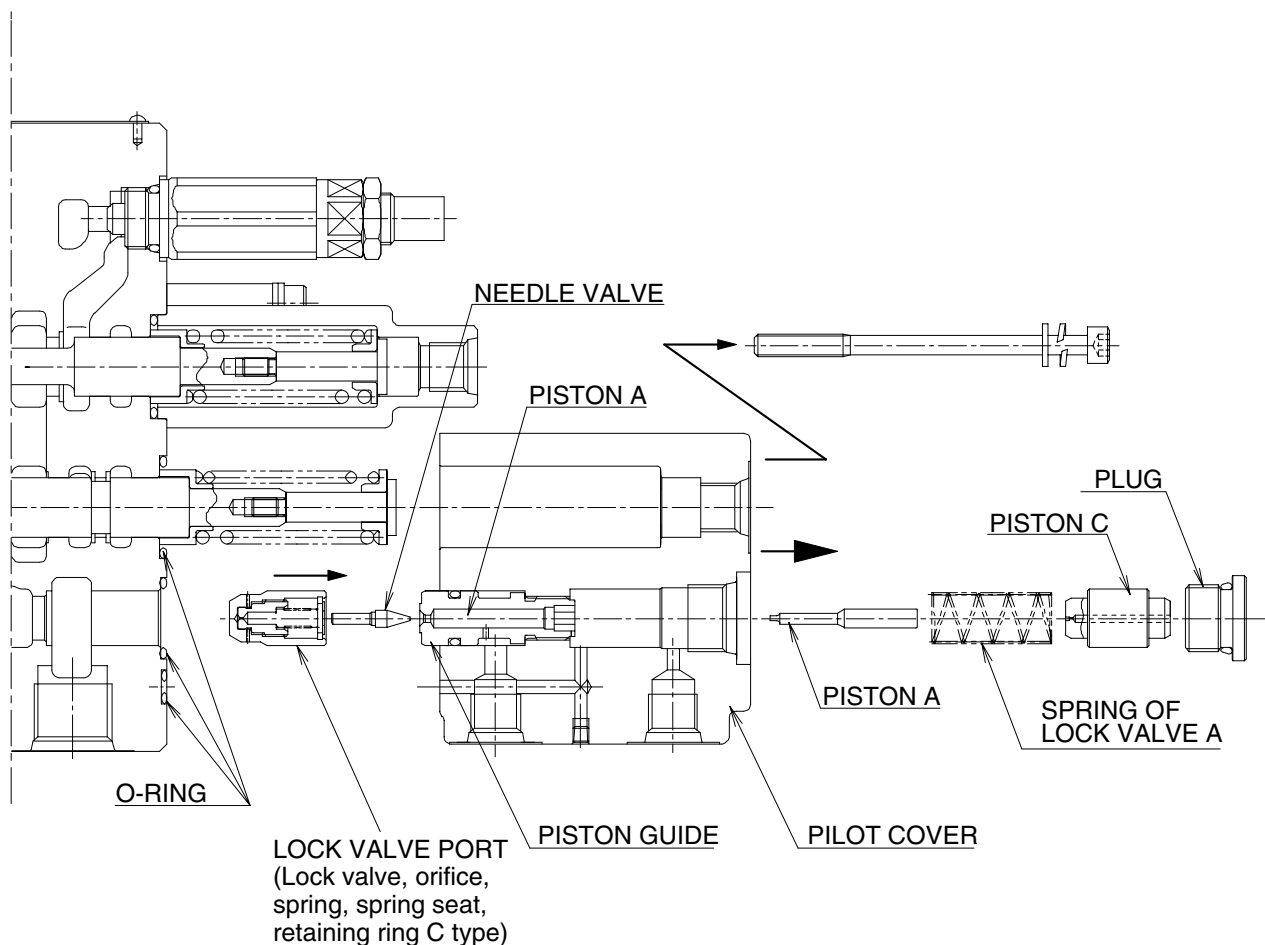

## 5) REMOVING LOAD CHECK VALVE

First, the valve body is fixed and it is made not to move.

A plug is removed using a 8mm allen wrench.

Next, spring of load check valve and load check valve are extracted using tweezers or a magnet.

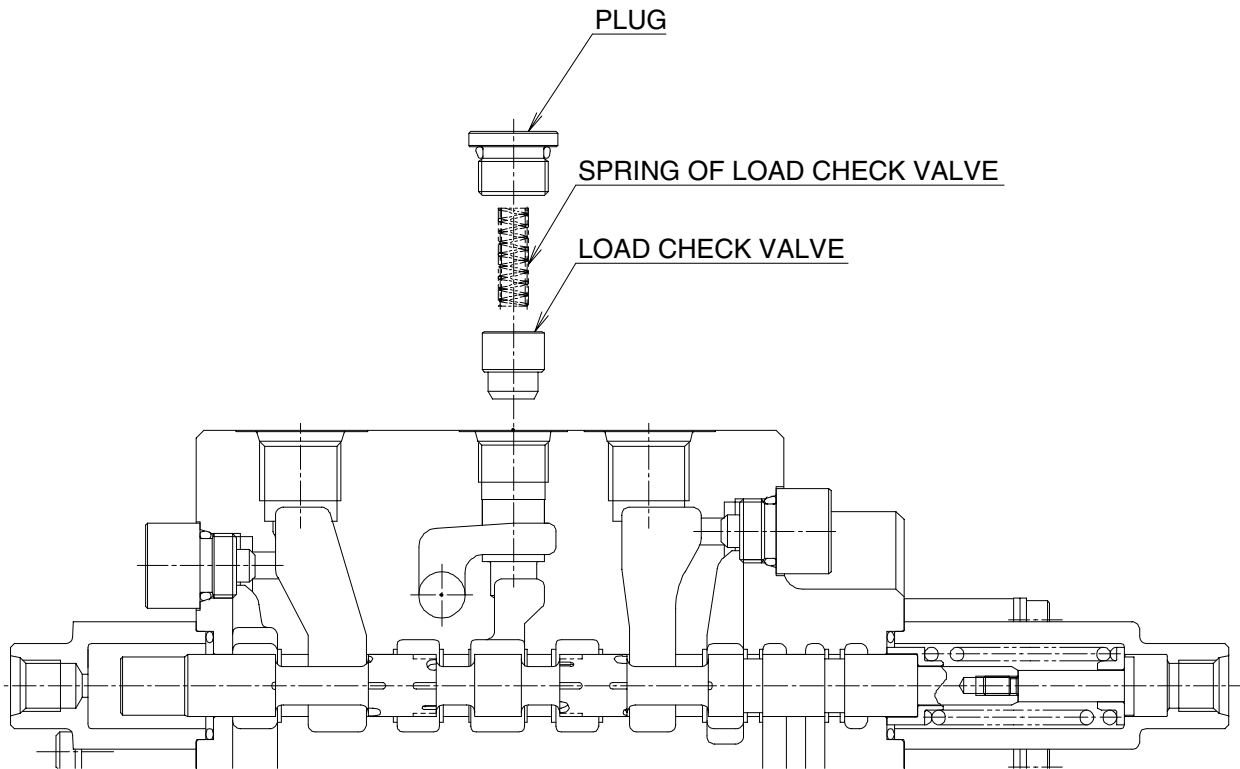

7078MCV04

## 6) REMOVING MAIN RELIEF VALVE AND OVERLOAD RELIEF VALVE

First, the main valve body is fixed and it is made not to move.

Next, a 32mm spanner is hooked on hex. portion(across flats 32mm) of main relief valve, and it is loosened and removed.

And, a 22mm spanner is hooked on hex. portion(across flats 22mm) of overload relief valve, and it is loosened and removed.

- ※ Do not remove the main relief valve using the hexagon width portion 19, 22 or 27mm.  
Do not remove the overload relief valve using the hexagon width portion 19mm.
- ※ Please treat it carefully so that a crack is not attached to the seat part of removed main relief valve and overload relief valve.
- ※ As the main relief valve and overload relief valve are one of the most important components on the function and safety, and also, it is difficult to re-set the pressure, so replace them by assembly if any deficiency is found.

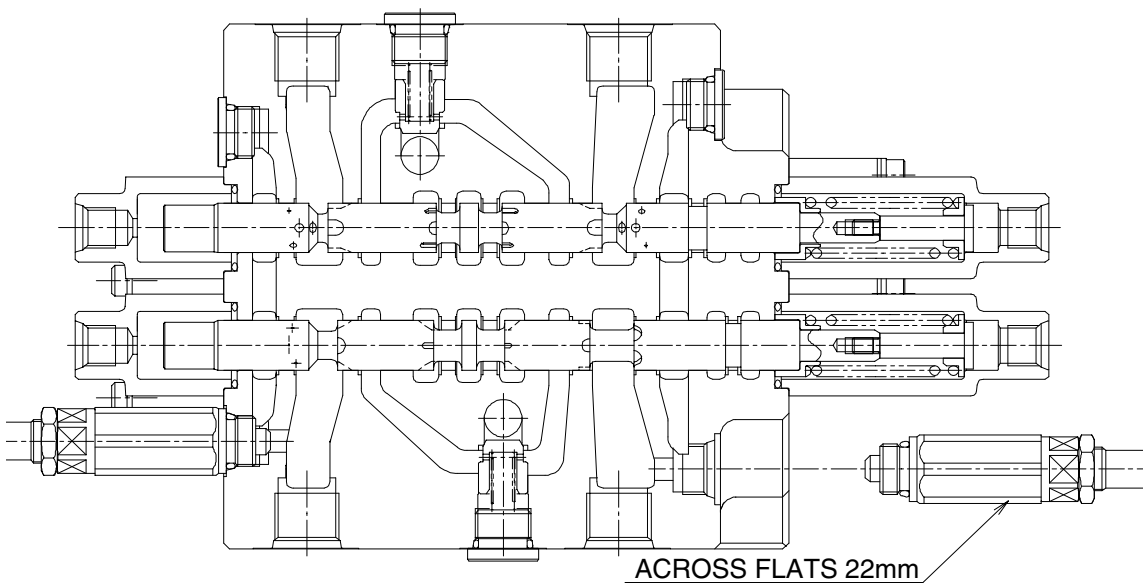
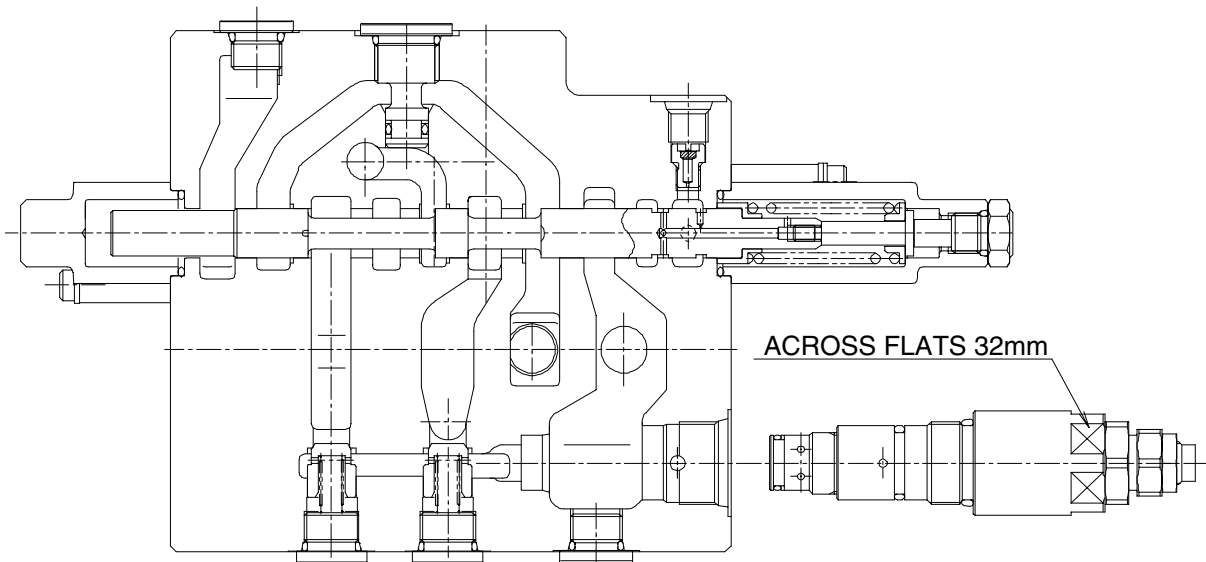

## 7) ASSEMBLING

(1) As the description on assembly is sentence only, refer to clause for disassembly for figures.

### (2) Cautions when assembling

- ① The unevenness of tightening torque and the contaminant during assembly may cause a failure.  
And observe the tightening torque specified in the description.
- ② When assembling, check up on the valve construction drawing, identify the number of part, and pay attention that there is no installation error and omission of part, etc.
- ③ When you assemble, please wash all parts by pure cleaning liquid, and immerse them in hydraulic oil as required, and assemble them.
- ④ Before applying loctite, clean and degrease the surface sufficiently, and apply it to two threads.  
(Overapplication may cause a malfunction due to the squeezing out)
- ⑤ For re-assembling, basically use only bland new seals for all portions.

### (3) Cautions when fitting seals

- ① For re-assembling, basically use only bland new seals for all portions.
- ② Pay attention to seals that they are free from deformation and flaw coming about when handling them.
- ③ Apply grease or hydraulic oil to the seals and seal fitting section to make the sliding smooth, unless otherwise specified.
- ④ Do not stretch the seals until it will be changed permanently.
- ⑤ Pay attention not to roll the O-ring when fitting. Because it is difficult for the twisted O-ring to be restored naturally after fitting, and it may cause oil leakage.

### (4) Installation of main relief valve and overload relief valve

The main body is fixed, and install main relief valve and overload relief valve on each port, and tighten them with regulation torque.

- Main relief valve : Tightening torque = 59~69N · m(6.0~7.0kgf · m)
- Overload relief valve : Tightening torque = 39~49N · m(4.0~5.0kgf · m)

※ Keep regulation torque at tightening, if not, distortion of body or oil leakage may be generated.

### (5) Installation of spool assembly

Confirm whether dusts etc. are not sticking on the spool and spool cavity in the body. Also confirm whether O-rings are securely installed on the bottom of the body flanges. (2 places, front and back of the body)

Insert each spool assembly into each spool cavity of the body confirming the position and direction.

Prior to insert, apply small amount of hydraulic oil on spool.

※ Even if insert of spools is not easy, do not press them in force. It may bring some deficiencies in function.

Push and pull spools several times by hand and confirm that they move without excessive resistance or slip-sticking. If any of them does not move smoothly, replace spool assembly or the valve assembly.

Following above, install pilot cover to the body flange securely from the spring side of spool assy and install bolts on the body with the regulation tightening torque.

After confirming existence of O-ring on opposite side of the body flange, install pilot cover to the flange securely, and install bolts on the body with regulation tightening torque.