

# GROUP 2 ENGINE SYSTEM

## 1. ENGINE AND ACCESSORIES MOUNTING

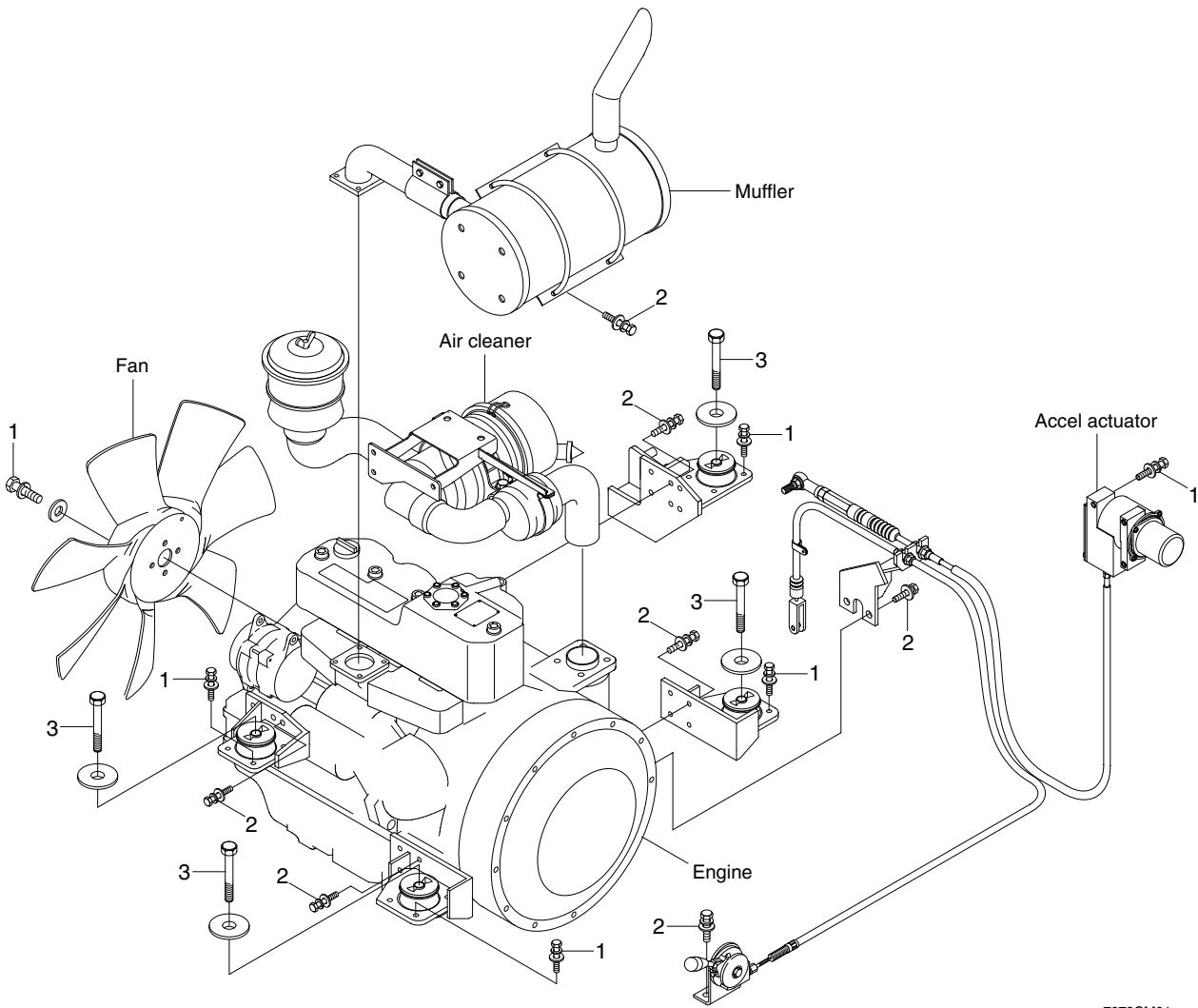

7079CM01

### · Tightening torque

Item	Size	kgf · m	lbf · ft
1	M 8 × 1.25	2.5 ± 0.5	18.1 ± 3.6
2	M 10 × 1.5	6.9 ± 1.4	49.9 ± 10.1

Item	Size	kgf · m	lbf · ft
3	M 16 × 2.0	25 ± 0.5	181 ± 19
-	-	-	-

## 2. COOLING SYSTEM AND FUEL TANK MOUNTING

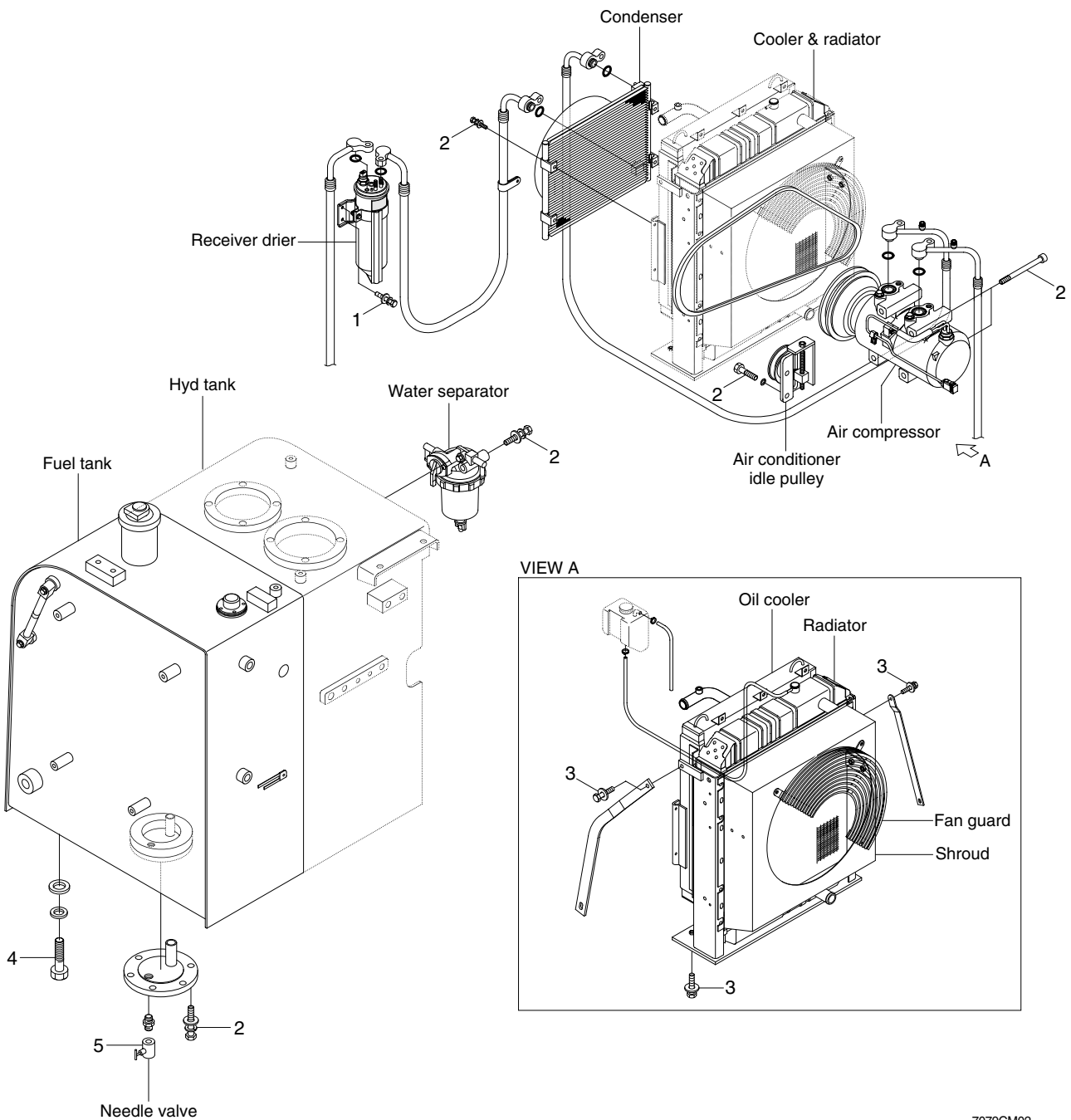

7079CM02

### · Tightening torque

Item	Size	kgf · m	lbf · ft
1	M 6 × 1.0	1.05 ± 0.2	7.6 ± 1.45
2	M 8 × 1.25	2.5 ± 0.5	18.1 ± 3.6
3	M12 × 1.75	12.2 ± 1.3	88.2 ± 9.4

Item	Size	kgf · m	lbf · ft
4	M 16 × 2.0	29.7 ± 4.5	215 ± 36.2
5	-	2.3 ± 0.6	16.6 ± 4.3
-	-	-	-