

# SECTION 1 GENERAL

Group 1 Safety Hints .....	1-1
Group 2 Specifications .....	1-9

## SECTION 1 GENERAL

### GROUP 1 SAFETY

#### FOLLOW SAFE PROCEDURE

Unsafe work practices are dangerous. Understand service procedure before doing work; Do not attempt shortcuts.

#### WEAR PROTECTIVE CLOTHING

Wear close fitting clothing and safety equipment appropriate to the job.

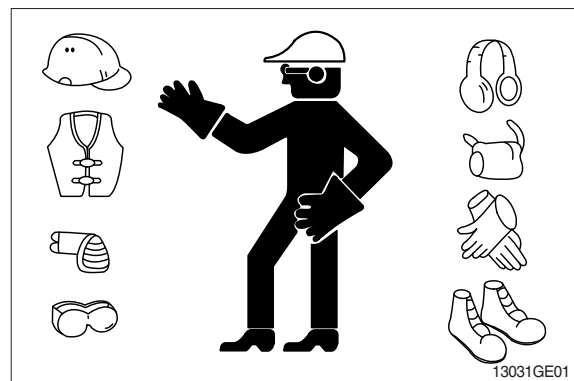

#### WARN OTHERS OF SERVICE WORK

Unexpected machine movement can cause serious injury.

Before performing any work on the excavator, attach a 「Do Not Operate」 tag on the right side control lever.

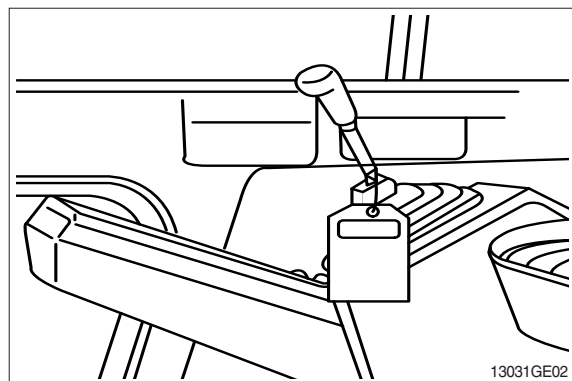

#### USE HANDHOLDS AND STEPS

Falling is one of the major causes of personal injury.

When you get on and off the machine, always maintain a three point contact with the steps and handrails and face the machine. Do not use any controls as handholds.

Never jump on or off the machine. Never mount or dismount a moving machine.

Be careful of slippery conditions on platforms, steps, and handrails when leaving the machine.

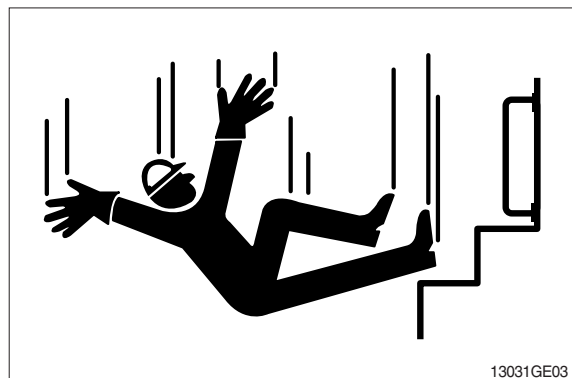

## PREPARE FOR EMERGENCIES

Be prepared if a fire starts.

Keep a first aid kit and fire extinguisher handy.

Keep emergency numbers for doctors, ambulance service, hospital, and fire department near your telephone.

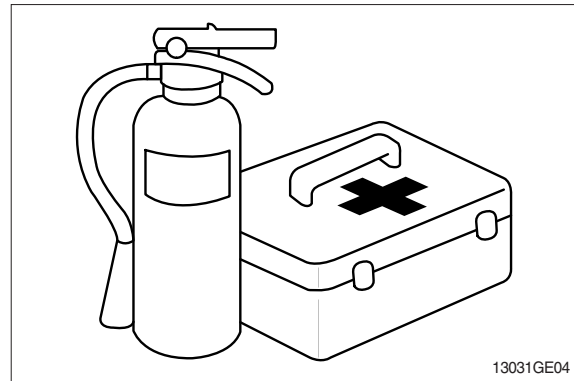

## PROTECT AGAINST FLYING DEBRIS

Guard against injury from flying pieces of metal or debris; Wear goggles or safety glasses.

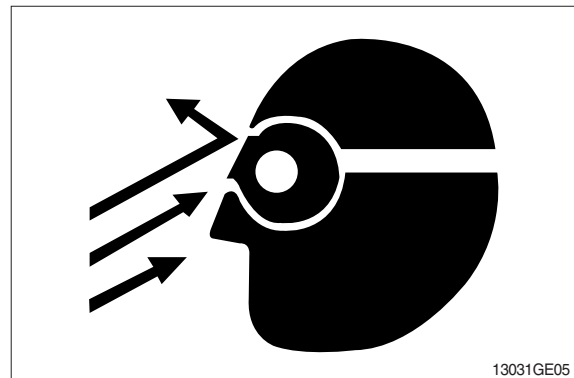

## PROTECT AGAINST NOISE

Prolonged exposure to loud noise can cause impairment or loss of hearing.

Wear a suitable hearing protective device such as earmuffs or earplugs to protect against objectionable or uncomfortable loud noises.

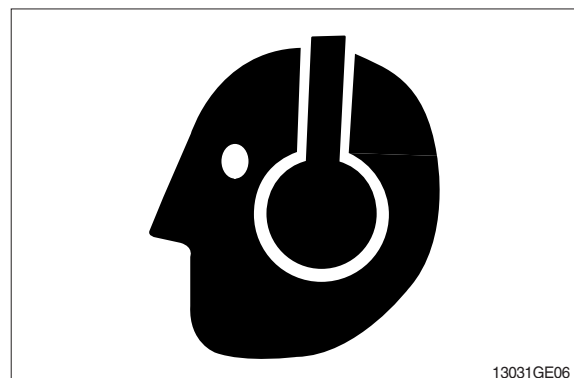

## AVOID POWER LINES

Serious injury or death can result from contact with electric lines.

Never move any part of the machine or load closer to electric line than 3m(10ft) plus twice the line insulator length.

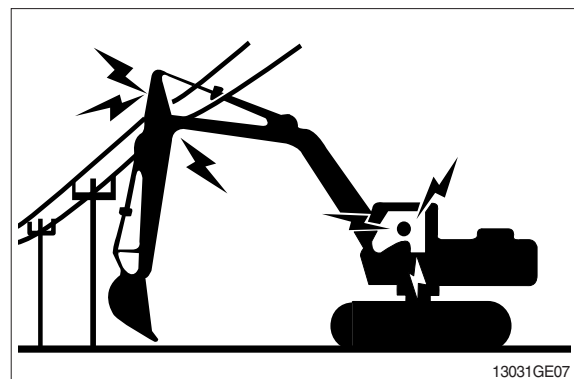

## KEEP RIDERS OFF EXCAVATOR

Only allow the operator on the excavator. Keep riders off.

Riders on excavator are subject to injury such as being struck by foreign objects and being thrown off the excavator. Riders also obstruct the operator's view resulting in the excavator being operated in an unsafe manner.

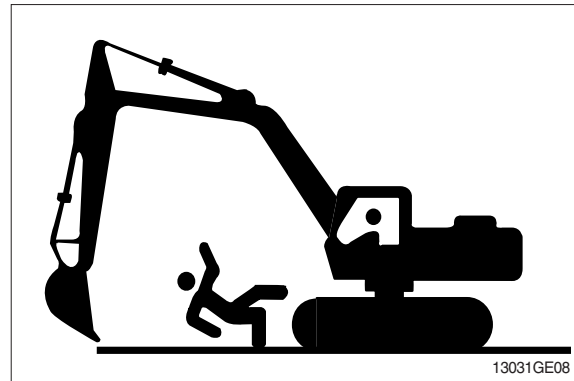

## MOVE AND OPERATE MACHINE SAFELY

Bystanders can be run over. Know the location of bystanders before moving, swinging, or operating the machine.

Always keep the travel alarm in working condition. It warns people when the excavator starts to move.

Use a signal person when moving, swinging, or operating the machine in congested areas. Coordinate hand signals before starting the excavator.

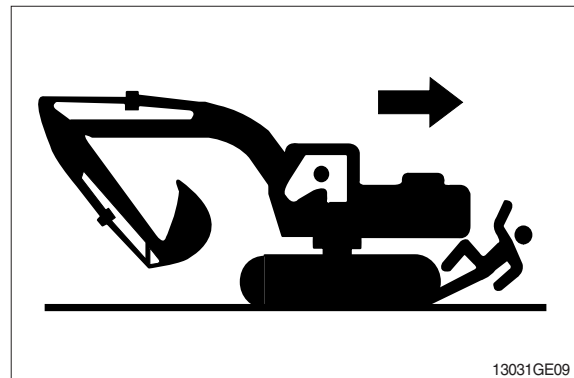

## OPERATE ONLY FROM OPERATOR'S SEAT

Avoid possible injury machine damage. Do not start engine by shorting across starter terminals.

NEVER start engine while standing on ground. Start engine only from operator's seat.



## PARK MACHINE SAFELY

Before working on the machine:

- Park machine on a level surface.
- Lower bucket to the ground.
- Turn auto idle switch off.
- Run engine at 1/2 speed without load for 2 minutes.
- Turn key switch to OFF to stop engine.  
Remove key from switch.
- Move pilot control shutoff lever to locked position.
- Allow engine to cool.

## SUPPORT MACHINE PROPERLY

Always lower the attachment or implement to the ground before you work on the machine. If you must work on a lifted machine or attachment, securely support the machine or attachment.

Do not support the machine on cinder blocks, hollow tiles, or props that may crumble under continuous load.

Do not work under a machine that is supported solely by a jack. Follow recommended procedures in this manual.

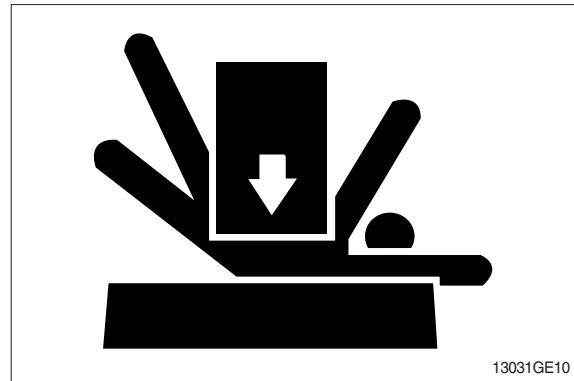

## SERVICE COOLING SYSTEM SAFELY

Explosive release of fluids from pressurized cooling system can cause serious burns.

Shut off engine. Only remove filler cap when cool enough to touch with bare hands.

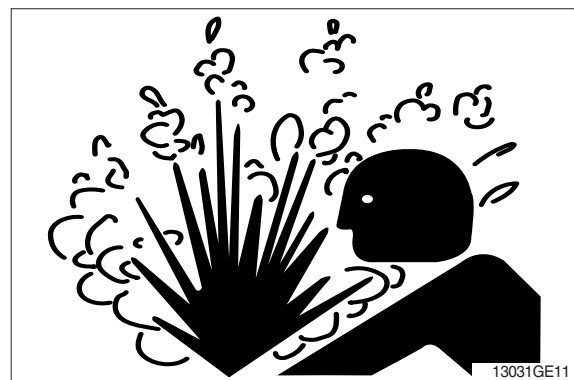

## HANDLE FLUIDS SAFELY-AVOID FIRES

Handle fuel with care; It is highly flammable. Do not refuel the machine while smoking or when near open flame or sparks. Always stop engine before refueling machine.

Fill fuel tank outdoors.

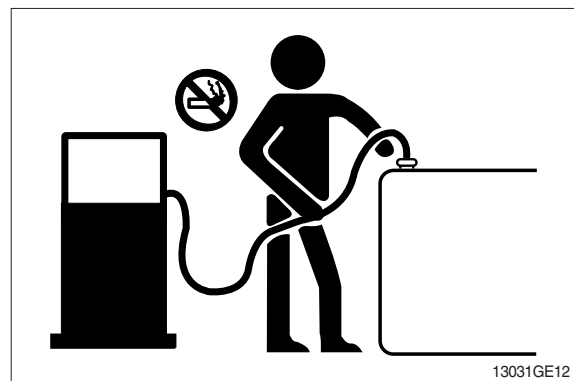

Store flammable fluids away from fire hazards. Do not incinerate or puncture pressurized containers.

Make sure machine is clean of trash, grease, and debris.

Do not store oily rags; They can ignite and burn spontaneously.



## BEWARE OF EXHAUST FUMES

Prevent asphyxiation. Engine exhaust fumes can cause sickness or death.

If you must operate in a building, be positive there is adequate ventilation. Either use an exhaust pipe extension to remove the exhaust fumes or open doors and windows to bring enough outside air into the area.

## REMOVE PAINT BEFORE WELDING OR HEATING

Avoid potentially toxic fumes and dust.

Hazardous fumes can be generated when paint is heated by welding, soldering, or using a torch.

Do all work outside or in a well ventilated area. Dispose of paint and solvent properly.

Remove paint before welding or heating:

- If you sand or grind paint, avoid breathing the dust. Wear an approved respirator.
- If you use solvent or paint stripper, remove stripper with soap and water before welding. Remove solvent or paint stripper containers and other flammable material from area. Allow fumes to disperse at least 15 minutes before welding or heating.

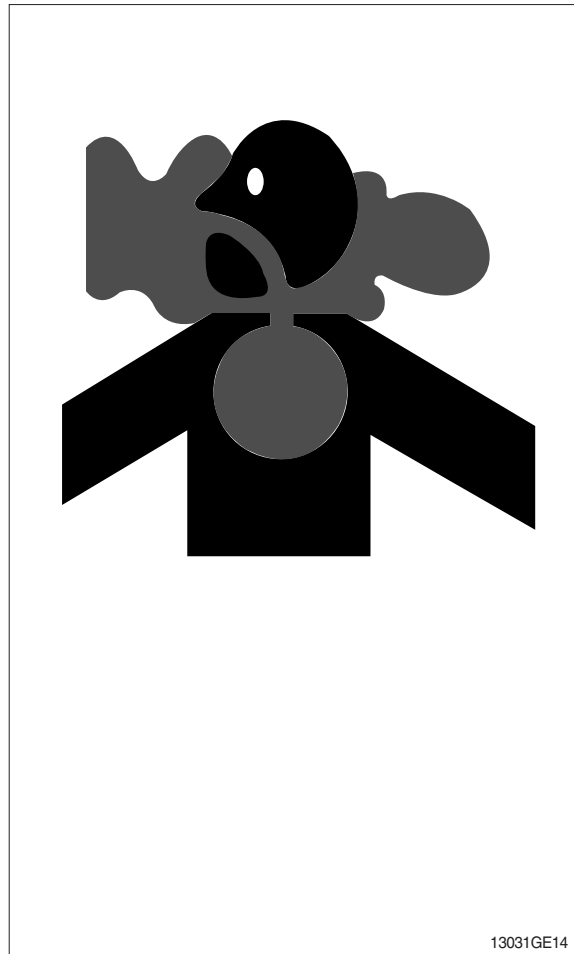

## ILLUMINATE WORK AREA SAFELY

Illuminate your work area adequately but safely. Use a portable safety light for working inside or under the machine. Make sure the bulb is enclosed by a wire cage. The hot filament of an accidentally broken bulb can ignite spilled fuel or oil.

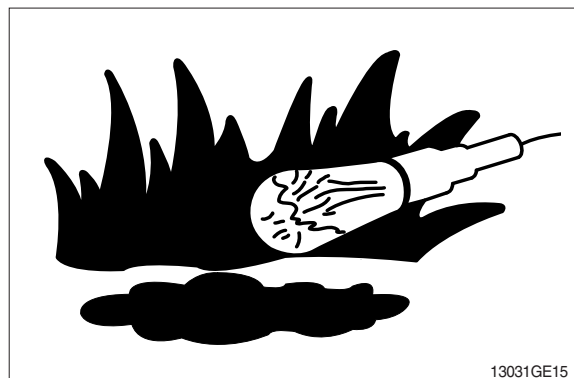

## SERVICE MACHINE SAFELY

Tie long hair behind your head. Do not wear a necktie, scarf, loose clothing or necklace when you work near machine tools or moving parts. If these items were to get caught, severe injury could result.

Remove rings and other jewelry to prevent electrical shorts and entanglement in moving parts.

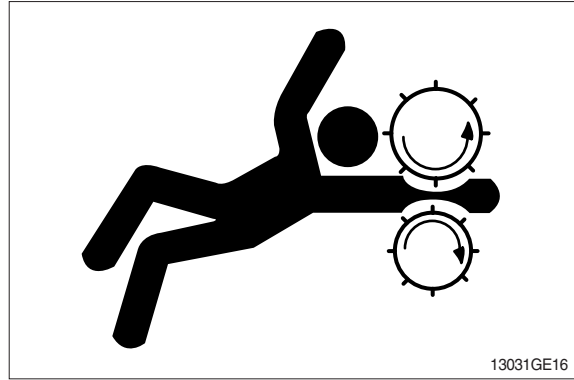

## STAY CLEAR OF MOVING PARTS

Entanglements in moving parts can cause serious injury.

To prevent accidents, use care when working around rotating parts.

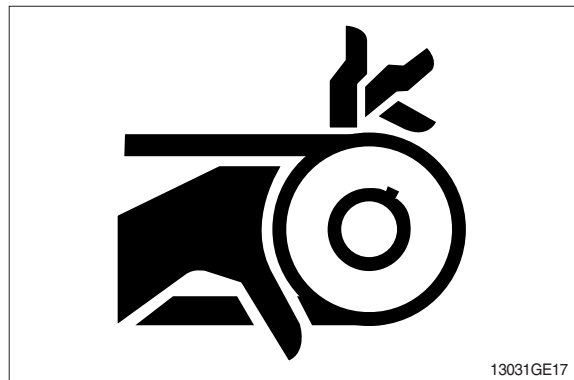

## AVOID HIGH PRESSURE FLUIDS

Escaping fluid under pressure can penetrate the skin causing serious injury.

Avoid the hazard by relieving pressure before disconnecting hydraulic or other lines. Tighten all connections before applying pressure.

Search for leaks with a piece of cardboard. Protect hands and body from high pressure fluids.

If an accident occurs, see a doctor immediately. Any fluid injected into the skin must be surgically removed within a few hours or gangrene may result.

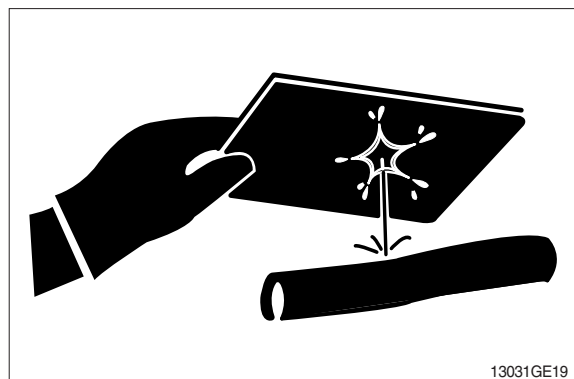

## AVOID HEATING NEAR PRESSURIZED FLUID LINES

Flammable spray can be generated by heating near pressurized fluid lines, resulting in severe burns to yourself and bystanders. Do not heat by welding, soldering, or using a torch near pressurized fluid lines or other flammable materials.

Pressurized lines can be accidentally cut when heat goes beyond the immediate flame area. Install fire resisting guards to protect hoses or other materials.



## PREVENT BATTERY EXPLOSIONS

Keep sparks, lighted matches, and flame away from the top of battery. Battery gas can explode.

Never check battery charge by placing a metal object across the posts. Use a volt-meter or hydrometer.

Do not charge a frozen battery; It may explode. Warm battery to 16°C (60°F).



## PREVENT ACID BURNS

Sulfuric acid in battery electrolyte is poisonous. It is strong enough to burn skin, eat holes in clothing, and cause blindness if splashed into eyes.

Avoid the hazard by:

1. Filling batteries in a well-ventilated area.
2. Wearing eye protection and rubber gloves.
3. Avoiding breathing fumes when electrolyte is added.
4. Avoiding spilling or dripping electrolyte.
5. Use proper jump start procedure.

If you spill acid on yourself:

1. Flush your skin with water.
2. Apply baking soda or lime to help neutralize the acid.
3. Flush your eyes with water for 10-15 minutes. Get medical attention immediately.

If acid is swallowed:

1. Drink large amounts of water or milk.
2. Then drink milk of magnesia, beaten eggs, or vegetable oil.
3. Get medical attention immediately.

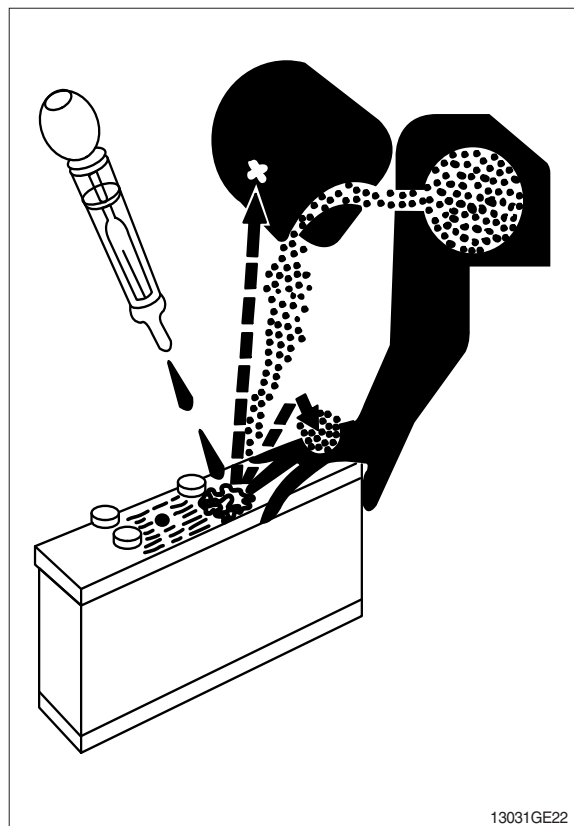



## USE TOOLS PROPERLY

Use tools appropriate to the work. Makeshift tools, parts, and procedures can create safety hazards.

Use power tools only to loosen threaded tools and fasteners.

For loosening and tightening hardware, use the correct size tools. DO NOT use U.S. measurement tools on metric fasteners. Avoid bodily injury caused by slipping wrenches.

Use only recommended replacement parts.(see Parts catalogue.)

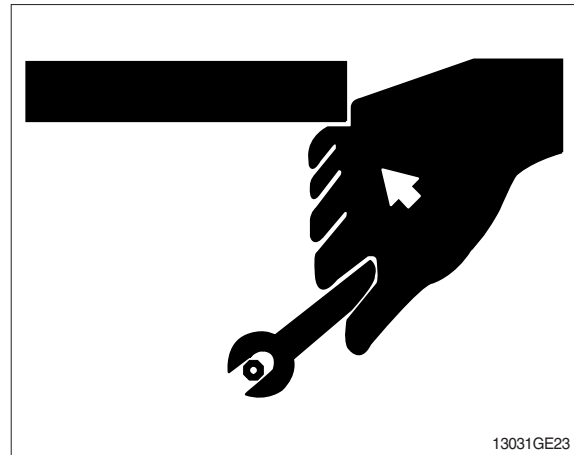

## DISPOSE OF FLUIDS PROPERLY

Improperly disposing of fluids can harm the environment and ecology. Before draining any fluids, find out the proper way to dispose of waste from your local environmental agency.

Use proper containers when draining fluids. Do not use food or beverage containers that may mislead someone into drinking from them.

DO NOT pour oil into the ground, down a drain, or into a stream, pond, or lake. Observe relevant environmental protection regulations when disposing of oil, fuel, coolant, brake fluid, filters, batteries, and other harmful waste.

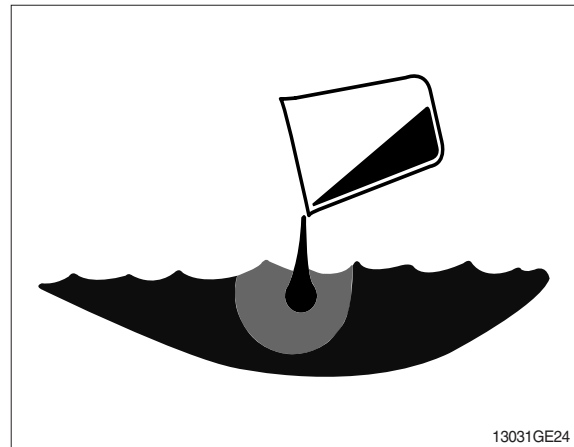

## REPLACE SAFETY SIGNS

Replace missing or damaged safety signs. See the machine operator's manual for correct safety sign placement.

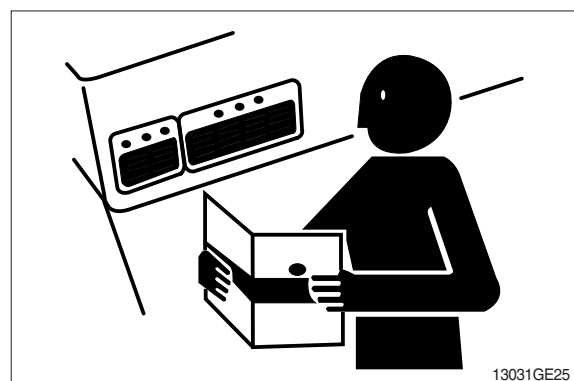

## LIVE WITH SAFETY

Before returning machine to customer, make sure machine is functioning properly, especially the safety systems. Install all guards and shields.

# GROUP 2 SPECIFICATIONS

## 1. MAJOR COMPONENT

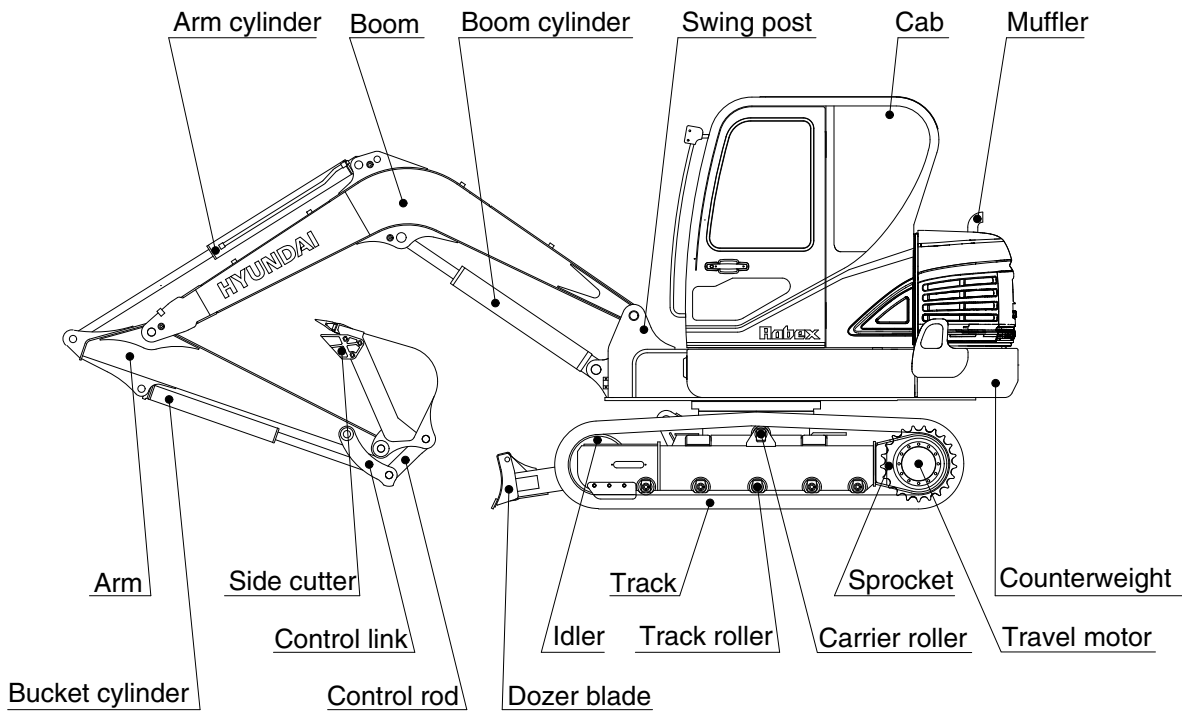
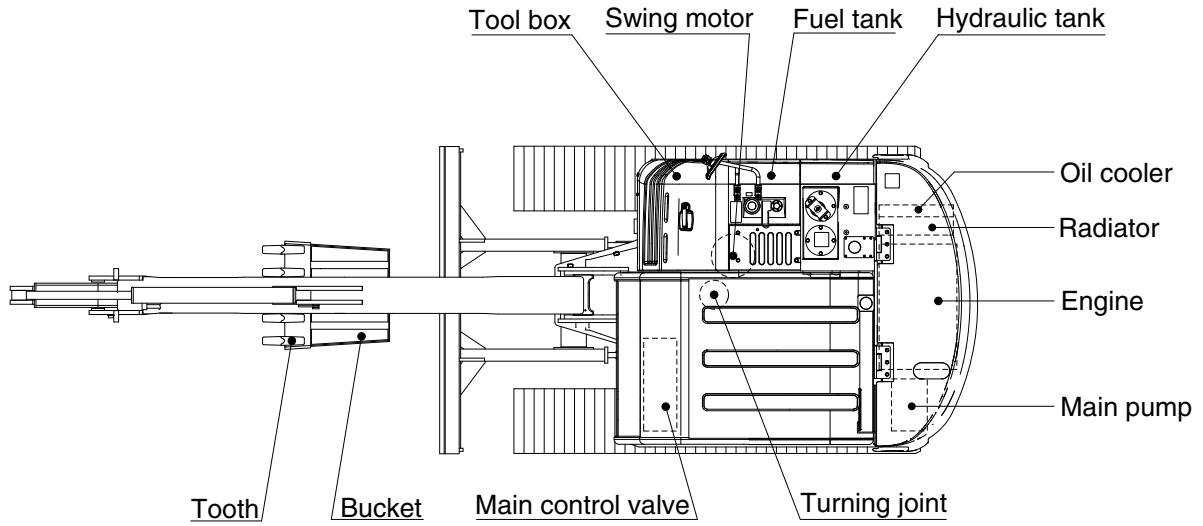

559A2SP01

## 2. SPECIFICATIONS

### 1) 3.0 m (9' 10") MONO BOOM, 1.6 m (5' 3") ARM, WITH BOOM SWING SYSTEM

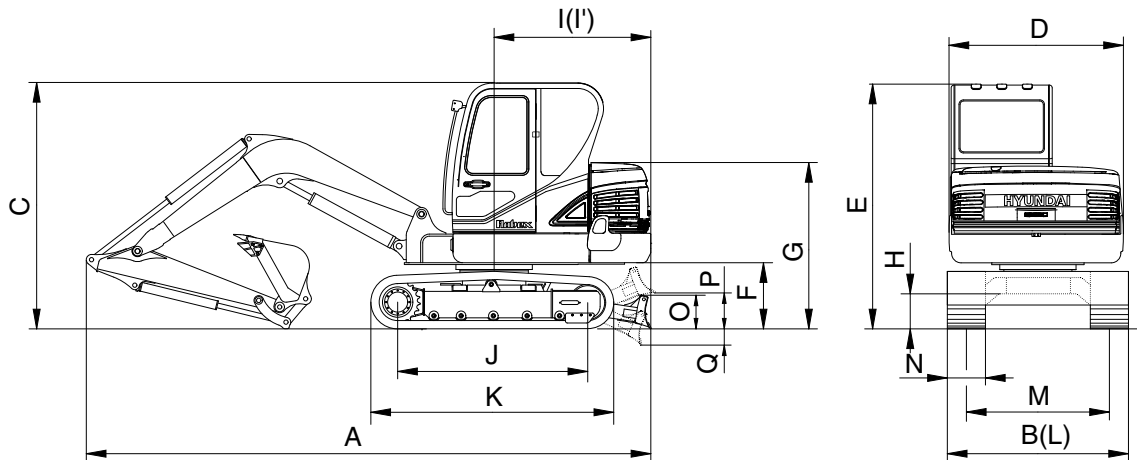

559A2SP02

Description		Unit	Specification
Operating weight		kg (lb)	5650 (12460)
Bucket capacity (SAE heaped), standard		m <sup>3</sup> (yd <sup>3</sup> )	0.18 (0.24)
Overall length	A	mm (ft-in)	5900 (19' 4")
Overall width, with 380 mm shoe	B		1920 (6' 4")
Overall height	C		2550 (8' 4")
Superstructure width	D		1850 (6' 1")
Overall height of cab	E		2550 (8' 4")
Ground clearance of counterweight	F		690 (2' 3")
Engine cover height	G		1690 (5' 7")
Minimum ground clearance	H		380 (1' 3")
Rear-end distance	I		1650 (5' 5")
Rear-end swing radius	I'		1650 (5' 5")
Distance between tumblers	J		1990 (6' 6")
Undercarriage length	K		2530 (8' 4")
Undercarriage width	L		1880 (6' 2")
Track gauge	M		1500 (4' 11")
Track shoe width, standard	N		380 (15")
Height of blade	O		350 (1' 2")
Ground clearance of blade up	P		390 (1' 3")
Depth of blade down	Q		590 (1' 11")
Travel speed (low/high)			km/hr (mph)
Swing speed		rpm	9.1
Gradeability		Degree (%)	35 (70)
Ground pressure (380 mm shoe)		kgf/cm <sup>2</sup> (psi)	0.34 (4.83)
Max traction force		kg (lb)	5300 (11680)

### 3. WORKING RANGE

#### 1) 3.0 m (9' 10") MONO BOOM WITH BOOM SWING SYSTEM

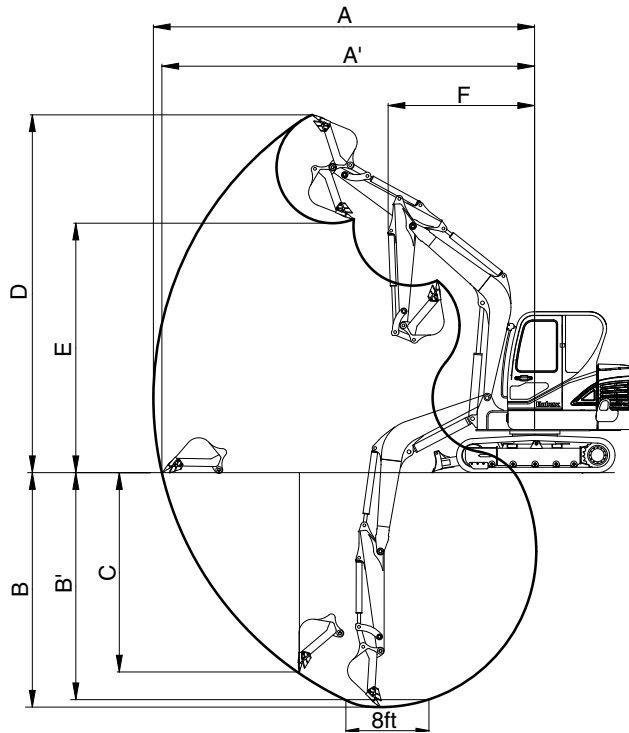

559A2SP03

Description		1.6 m (5' 3") Arm
Max digging reach	A	6150 mm (20' 2")
Max digging reach on ground	A'	6010 mm (19' 9")
Max digging depth	B	3820 mm (12' 6")
Max digging depth (8ft level)	B'	3420 mm (11' 3")
Max vertical wall digging depth	C	3200 mm (10' 6")
Max digging height	D	5780 mm (19' 0")
Max dumping height	E	4050 mm (13' 3")
Min swing radius	F	2350 mm ( 7' 9")
Boom swing radius (left/right)		80°/50°
Bucket digging force	SAE	37.7 kN
		3850 kgf
		8490 lbf
	ISO	42.4 kN
		4330 kgf
		9550 lbf
Arm crowd force	SAE	28.4 kN
		2900 kgf
		6390 lbf
	ISO	31.9 kN
		3260 kgf
		7190 lbf

#### 4. WEIGHT











Item	kg	lb
Upperstructure assembly	2710	5970
Main frame weld assembly	600	1320
Engine assembly	270	595
Main pump assembly	30	70
Main control valve assembly	45	100
Swing motor assembly	75	165
Hydraulic oil tank assembly	90	200
Fuel tank assembly	60	130
Boom swing post	110	240
Counterweight	235	520
Cab assembly	350	770
Lower chassis assembly	2150	4740
Track frame weld assembly	700	1540
Swing bearing	90	200
Travel motor assembly	80	180
Turning joint	30	70
Track recoil spring	20	45
Idler & tension body	60	130
Carrier roller	12	26
Track roller	12	26
Sprocket	20	40
Track-chain assembly (380 mm standard triple grouser shoe)	320	710
Dozer blade assembly	210	460
Front attachment assembly (3.0 m boom, 1.6 m arm, 0.18 m <sup>3</sup> SAE heaped bucket)	790	1740
3.0 m boom assembly	240	530
1.6 m arm assembly	114	251
0.18 m <sup>3</sup> SAE heaped bucket	170	370
Boom cylinder assembly	78	172
Arm cylinder assembly	65	143
Bucket cylinder assembly	37	82
Bucket control link assembly	40	90
Dozer cylinder assembly	40	90
Boom swing cylinder assembly	40	90

## 5. LIFTING CAPACITIES

Type	Boom	Arm	Counterweight	Shoe	Wheel	Dozer		Outrigger	
MONO BOOM	Length [mm]	Length [mm]	weight [kg]	width [mm]	width [mm]	Front	Rear	Front	Rear
	3000	1600	235	380	-	Down	-	-	-

·  : Rating over-front

·  : Rating over-side or 360 degree

Load point height		Load radius								At max. reach		
		2.0 m (7 ft)		3.0 m (10 ft)		4.0 m (13 ft)		5.0 m (16 ft)		Capacity		Reach
												m (ft)
5.0 m (16 ft)	kg									*950	*950	4.12
	lb									*2090	*2090	(13.5)
4.0 m (13 ft)	kg					*1020	*1020			*980	780	5.08
	lb					*2250	*2250			*2160	1720	(16.7)
3.0 m (10 ft)	kg					*1090	*1090			*1010	650	5.60
	lb					*2400	*2400			*2230	1430	(18.4)
2.0 m (7 ft)	kg	*3050	*3050	*1690	*1690	*1320	1100	*1170	760	*1050	590	5.84
	lb	*6720	*6720	*3730	*3730	*2910	2430	*2580	1680	*2310	1300	(19.2)
1.0 m (3 ft)	kg			*2360	1610	*1600	1040	*1280	740	*1100	580	5.85
	lb			*5200	3550	*3530	2290	*2820	1630	*2430	1280	(19.2)
Ground Line	kg	*2350	*2350	*2700	1540	*1790	1000	*1350	720	*1140	610	5.63
	lb	*5180	*5180	*5950	3400	*3950	2200	*2980	1590	*2510	1340	(18.5)
-1.0 m (-3 ft)	kg	*3600	3020	*2670	1530	*1800	990			*1180	700	5.13
	lb	*7940	6660	*5890	3370	*3970	2180			*2600	1540	(16.8)
-2.0 m (-7 ft)	kg	*3770	3060	*2300	1540					*1140	960	4.23
	lb	*8310	6750	*5070	3400					*2510	2120	(13.9)
-3.0 m (-10 ft)	kg	*2040	*2040									
	lb	*4500	*4500									

### ※ Note

1. Lifting capacity are based on SAE J1097 and ISO 10567.
2. Lifting capacity of the ROBEX series does not exceed 75% of tipping load with the machine on firm, level ground or 87% of full hydraulic capacity.
3. The lift-point is bucket pivot mounting pin on the arm (without bucket mass).
4. \*indicates load limited by hydraulic capacity.

### ※ Lifting capacities are based upon a standard machine conditions.

Lifting capacities will vary with different work tools, ground conditions and attachments.

The difference between the weight of a work tool attachment must be subtracted.

Consult your Hyundai dealer regarding the lifting capacities for specific work tools and attachments.











### ▲ Failure to comply to the rated load can cause possible personal injury or property damage.

Make adjustments to the rated load as necessary for non-standard configurations.

Type	Boom	Arm	Counterweight	Shoe	Wheel	Dozer		Outtriger	
MONO BOOM	Length [mm]	Length [mm]	weight [kg]	width [mm]	width [mm]	Front	Rear	Front	Rear
	3000	1600	235	380	-	Up	-	-	-

·  : Rating over-front











·  : Rating over-side or 360 degree

Load point height		Load radius								At max. reach		
		2.0 m (7 ft)		3.0 m (10 ft)		4.0 m (13 ft)		5.0 m (16 ft)		Capacity		Reach
												m (ft)
5.0 m (16 ft)	kg lb									*950 *2090	*950 *2090	4.12 (13.5)
4.0 m (13 ft)	kg lb					*1020 *2250	*1020 *2250			*980 *2160	740 1630	5.08 (16.7)
3.0 m (10 ft)	kg lb					*1090 *2400	*1080 *2380			890 1960	610 1340	5.60 (18.4)
2.0 m (7 ft)	kg lb	*3050 *6720	*3050 *6720	*1690 *3730	1630 3590	*1320 *2910	1030 2270	1040 2290	710 1570	810 1790	550 1210	5.84 (19.2)
1.0 m (3 ft)	kg lb			2250 4960	1510 3330	1430 3150	980 2160	1010 2230	690 1520	800 1760	540 1190	5.85 (19.2)
Ground Line	kg lb	*2350 *5180	*2350 *5180	2170 4780	1440 3170	1390 3060	940 2070	990 3180	670 1480	840 1850	570 1260	5.63 (18.5)
-1.0 m (-3 ft)	kg lb	*3600 *7940	2780 6130	2150 4740	1420 3130	1370 3020	930 2050			970 2140	600 1460	5.13 (16.8)
-2.0 m (-7 ft)	kg lb	*3770 *8310	2830 6240	2170 4780	1440 3170					*1140 *2510	900 1980	4.23 (13.9)
-3.0 m (-10 ft)	kg lb	*2040 *4500	*2040 *4500									

Type		Boom	Arm	Counterweight	Shoe	Wheel	Dozer		Outrigger	
MONO BOOM	ANGLE DOZER BLADE	Length [mm]	Length [mm]	weight [kg]	width [mm]	width [mm]	Front	Rear	Front	Rear
		3000	1600	235	380	-	Down	-	-	-

·  : Rating over-front

·  : Rating over-side or 360 degree











Load point height		Load radius								At max. reach		
		2.0 m (6.6 ft)		3.0 m (9.8 ft)		4.0 m (13.1 ft)		5.0 m (16.4 ft)		Capacity		Reach
												m (ft)
5.0 m (16 ft)	kg lb											
4.0 m (13 ft)	kg lb					*1240 *2730	1140 2510			*1290 *2840	1020 2250	4.26 (14.0)
3.0 m (10 ft)	kg lb					*1290 *2840	1120 2470			*1260 *2780	810 1790	4.87 (16.0)
2.0 m (7 ft)	kg lb			*1980 *4370	1660 3660	*1510 *3330	1080 2380	*1340 *2950	770 1700	*1270 *2800	720 1590	5.17 (17.0)
1.0 m (3 ft)	kg lb			*2620 *5780	1550 3420	*1780 *3920	1030 2270	*1430 *3150	750 1650	*1360 *3000	700 1540	5.24 (17.2)
Ground Line	kg lb			*2880 *6350	1490 3280	*1940 *4280	1000 2200	*1470 *3240	730 1610	*1440 *3170	720 1590	5.08 (16.7)
-1.0 m (-3 ft)	kg lb	*3100 *6830	2880 6350	*2780 *6130	1480 3260	*1910 *4210	990 2180			*1500 *3310	800 1760	4.66 (15.3)
-2.0 m (-7 ft)	kg lb	*3640 *8020	2940 6480	*2310 *5090	1510 3330					*1550 *3420	1050 2310	3.89 (12.8)
-3.0 m (-10 ft)	kg lb											



Type		Boom	Arm	Counterweight	Shoe	Wheel	Dozer		Outrigger	
MONO BOOM	ANGLE DOZER BLADE	Length [mm]	Length [mm]	weight [kg]	width [mm]	width [mm]	Front	Rear	Front	Rear
		3000	1600	235	380	-	Up	-	-	-

·  : Rating over-front

·  : Rating over-side or 360 degree









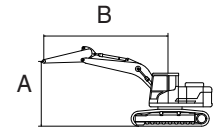

Load point height		Load radius								At max. reach		
		2.0 m (6.6 ft)		3.0 m (9.8 ft)		4.0 m (13.1 ft)		5.0 m (16.4 ft)		Capacity		Reach
												m (ft)
5.0 m (16 ft)	kg lb											
4.0 m (13 ft)	kg lb					1210 2670	1050 2310			1080 2380	940 2070	4.26 (14.0)
3.0 m (10 ft)	kg lb					1190 2620	1030 2270			860 1900	750 1650	4.87 (16.0)
2.0 m (7 ft)	kg lb			1800 3970	1520 3350	1150 2540	990 2180	810 1790	700 1540	760 1680	660 1460	5.17 (17.0)
1.0 m (3 ft)	kg lb			1680 3700	1410 3110	1100 2430	940 2070	790 1740	680 1500	730 1610	640 1410	5.24 (17.2)
Ground Line	kg lb			1620 3570	1350 2980	1060 2340	910 2010	770 1700	670 1480	760 1680	650 1430	5.08 (16.7)
-1.0 m (-3 ft)	kg lb	*3100 *6830	2570 5670	1610 3550	1340 2950	1050 2310	900 1980			850 1870	730 1610	4.66 (15.3)
-2.0 m (-7 ft)	kg lb	3350 7390	2620 5780	1630 3590	1370 3020					1120 2470	960 2120	3.89 (12.8)
-3.0 m (-10 ft)	kg lb											

Type	Boom	Arm	Counterweight	Shoe	Wheel	Dozer		Outrigger	
MONO BOOM	Length [mm]	Length [mm]	weight [kg]	width [mm]	width [mm]	Front	Rear	Front	Rear
	3000	1600	285	400	-	Down	-	-	-

•  : Rating over-front

•  : Rating over-side or 360 degree











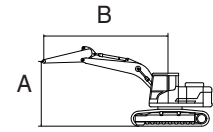

Load point height		Load radius								At max. reach		
		2.0 m (6.6 ft)		3.0 m (9.8 ft)		4.0 m (13.1 ft)		5.0 m (16.4 ft)		Capacity		Reach
												m (ft)
4.0 m (13.1 ft)	kg					*1240	1130			*1290	1010	4.26
	lb					*2730	2490			*2840	2230	(14.0)
3.0 m (9.8 ft)	kg					*1290	1110			*1260	810	4.87
	lb					*2840	2450			*2780	1790	(16.0)
2.0 m (6.6 ft)	kg			*1980	1650	*1510	1070	*1340	760	*1270	720	5.17
	lb			*4370	3640	*3330	2360	*2950	1680	*2800	1590	(17.0)
1.0 m (3.3 ft)	kg			*2620	1530	*1780	1020	*1430	740	*1360	690	5.24
	lb			*5780	3370	*3920	2250	*3150	1630	*3000	1520	(17.2)
Ground Line	kg			*2880	1480	*1940	990	*1470	730	*1440	710	5.08
	lb			*6350	3260	*4280	2180	*3240	1610	*3170	1570	(16.7)
-1.0 m (-3.3 ft)	kg	*3100	2860	*2780	1470	*1910	980			*1500	800	4.66
	lb	*6830	6310	*6130	3240	*4210	2160			*3310	1760	(15.3)
-2.0 m (-6.6 ft)	kg	*3640	2920	*2310	1490					*1550	1040	3.89
	lb	*8020	6440	*5090	3280					*3420	2290	(12.8)
-3.0 m (-9.8 ft)	kg											
	lb											

Type	Boom	Arm	Counterweight	Shoe	Wheel	Dozer		Outrigger	
MONO BOOM	Length [mm]	Length [mm]	weight [kg]	width [mm]	width [mm]	Front	Rear	Front	Rear
	3000	1600	285	400	-	Up	-	-	-

•  : Rating over-front

•  : Rating over-side or 360 degree











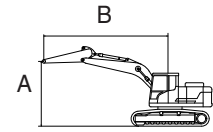

Load point height		Load radius								At max. reach		
		2.0 m (6.6 ft)		3.0 m (9.8 ft)		4.0 m (13.1 ft)		5.0 m (16.4 ft)		Capacity		Reach
												m (ft)
4.0 m (13.1 ft)	kg					*1240	1030			1140	930	4.26
	lb					*2730	2270			2510	2050	(14.0)
3.0 m (9.8 ft)	kg					1260	1020			910	740	4.87
	lb					2780	2250			2010	1630	(16.0)
2.0 m (6.6 ft)	kg			1910	1500	1220	980	860	690	810	650	5.17
	lb			4210	3310	2690	2160	1900	1520	1790	1430	(17.0)
1.0 m (3.3 ft)	kg			1780	1380	1170	930	840	670	780	630	5.24
	lb			3920	3040	2580	2050	1850	1480	1720	1390	(17.2)
Ground Line	kg			1730	1330	1130	890	820	660	810	640	5.08
	lb			3810	2930	2490	1960	1810	1460	1790	1410	(16.7)
-1.0 m (-3.3 ft)	kg	*3100	2530	1720	1320	1120	880			910	720	4.66
	lb	*6830	5580	3790	2910	2470	1940			2010	1590	(15.3)
-2.0 m (-6.6 ft)	kg	3600	2580	1740	1350					1190	940	3.89
	lb	7940	5690	3840	2980					2620	2070	(12.8)
-3.0 m (-9.8 ft)	kg											
	lb											

Type	Boom	Arm	Counterweight	Shoe	Wheel	Dozer		Outrigger	
MONO BOOM	Length [mm]	Length [mm]	weight [kg]	width [mm]	width [mm]	Front	Rear	Front	Rear
	3000	1900	285	400	-	Down	-	-	-

·  : Rating over-front

·  : Rating over-side or 360 degree











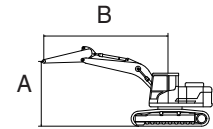

Load point height		Load radius										At max. reach		
		1.0 m (3.3 ft)		2.0 m (6.6 ft)		3.0 m (9.8 ft)		4.0 m (13.1 ft)		5.0 m (16.4 ft)		Capacity		Reach
														m (ft)
5.0 m (16.4 ft)	kg											*1210	*1210	3.64 (11.9)
	lb											*2670	*2670	
4.0 m (13.1 ft)	kg							*1070	*1070			*1090	890	4.63 (15.2)
	lb							*2360	*2360			*2400	1960	
3.0 m (9.8 ft)	kg							*1150	1130	*1180	780	*1030	730	5.19 (17.0)
	lb							*2540	2490	*2600	1720	*2270	1610	
2.0 m (6.6 ft)	kg					*1750	1680	*1400	1080	*1250	770	*1040	660	5.47 (18.0)
	lb					*3860	3700	*3090	2380	*2760	1700	*2290	1460	
1.0 m (3.3 ft)	kg					*2460	1560	*1690	1030	*1380	740	*1100	640	5.53 (18.2)
	lb					*5420	3440	*3730	2270	*3040	1630	*2430	1410	
Ground Line	kg			*1490	*1490	*2840	1490	*1910	990	*1460	720	*1230	650	5.38 (17.7)
	lb			*3280	*3280	*6260	3280	*4210	2180	*3220	1590	*2710	1430	
-1.0 m (-3.3 ft)	kg	*1930	*1930	*2720	*2720	*2850	1470	*1940	970			*1400	720	5.00 (16.4)
	lb	*4250	*4250	*6000	*6000	*6280	3240	*4280	2140			*3090	1590	
-2.0 m (-6.6 ft)	kg	*3150	*3150	*4120	*2890	*2510	1480	*1690	980			*1460	900	4.30 (14.1)
	lb	*6940	*6940	*9080	*6370	*5530	3260	*3730	2160			*3220	1980	
-3.0 m (-9.8 ft)	kg			*2480	*2480	*1440	*1440					*1430	*1430	3.01 (9.9)
	lb			*5470	*5470	*3170	*3170					*3150	*3150	

Type	Boom	Arm	Counterweight	Shoe	Wheel	Dozer		Outrigger	
MONO BOOM	Length [mm]	Length [mm]	weight [kg]	width [mm]	width [mm]	Front	Rear	Front	Rear
	3000	1900	285	400	-	Up	-	-	-

·  : Rating over-front

·  : Rating over-side or 360 degree











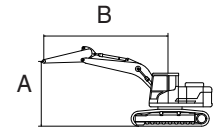

Load point height		Load radius										At max. reach		
		1.0 m (3.3 ft)		2.0 m (6.6 ft)		3.0 m (9.8 ft)		4.0 m (13.1 ft)		5.0 m (16.4 ft)		Capacity		Reach
														m (ft)
5.0 m (16.4 ft)	kg lb											*1210 *2670	1200 2650	3.64 (11.9)
4.0 m (13.1 ft)	kg lb							*1070 *2360	1050 2310			1010 2230	820 1810	4.63 (15.2)
3.0 m (9.8 ft)	kg lb							*1150 *2540	1030 2270	880 1940	720 1590	830 1830	670 1480	5.19 (17.0)
2.0 m (6.6 ft)	kg lb					*1750 *3860	1530 3370	1230 2710	990 2180	870 1920	700 1540	750 1650	600 1320	5.47 (18.0)
1.0 m (3.3 ft)	kg lb					1820 4010	1410 3110	1180 2600	940 2070	840 1850	680 1500	720 1590	580 1280	5.53 (18.2)
Ground Line	kg lb			*1490 *3280	*1490 *3280	1740 3840	1340 2950	1140 2510	900 1980	820 1810	660 1460	740 1630	590 1300	5.38 (17.7)
-1.0 m (-3.3 ft)	kg lb	*1930 *4250	*1930 *4250	*2720 *6000	2520 5560	1720 3790	1320 2910	1120 2470	880 1940			820 1810	650 1430	5.00 (16.4)
-2.0 m (-6.6 ft)	kg lb	*3150 *6940	*3150 *6940	3580 7890	2560 5640	1730 3810	1340 2950	1130 2490	890 1960			1020 2250	810 1790	4.30 (14.1)
-3.0 m (-9.8 ft)	kg lb			*2480 *5470	*2480 *5470	*1440 *3170	1400 3090					*1430 *3150	1400 3090	3.01 (9.9)

Type	Boom	Arm	Counterweight	Shoe	Wheel	Dozer		Outrigger	
MONO BOOM	Length [mm]	Length [mm]	weight [kg]	width [mm]	width [mm]	Front	Rear	Front	Rear
	3000	1600	335	400	-	Down	-	-	-

·  : Rating over-front

·  : Rating over-side or 360 degree











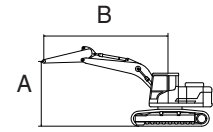

Load point height		Load radius								At max. reach		
		2.0 m (6.6 ft)		3.0 m (9.8 ft)		4.0 m (13.1 ft)		5.0 m (16.4 ft)		Capacity		Reach
												m (ft)
4.0 m (13.1 ft)	kg					*1240	1160			*1290	1040	4.26
	lb					*2730	2560			*2840	2290	(14.0)
3.0 m (9.8 ft)	kg					*1290	1140			*1260	830	4.87
	lb					*2840	2510			*2780	1830	(16.0)
2.0 m (6.6 ft)	kg			*1980	1690	*1510	1100	*1340	780	*1270	740	5.17
	lb			*4370	3730	*3330	2430	*2950	1720	*2800	1630	(17.0)
1.0 m (3.3 ft)	kg			*2620	1570	*1780	1050	*1430	760	*1360	710	5.24
	lb			*5780	3460	*3920	2310	*3150	1680	*3000	1570	(17.2)
Ground Line	kg			*2880	1520	*1940	1010	*1470	750	*1440	730	5.08
	lb			*6350	3350	*4280	2230	*3240	1650	*3170	1610	(16.7)
-1.0 m (-3.3 ft)	kg	*3100	2940	*2780	1510	*1910	1000			*1500	820	4.66
	lb	*6830	6480	*6130	3330	*4210	2200			*3310	1810	(15.3)
-2.0 m (-6.6 ft)	kg	*3640	2990	*2310	1540					*1550	1070	3.89
	lb	*8020	6590	*5090	3400					*3420	2360	(12.8)
-3.0 m (-9.8 ft)	kg											
	lb											

Type	Boom	Arm	Counterweight	Shoe	Wheel	Dozer		Outrigger	
MONO BOOM	Length [mm]	Length [mm]	weight [kg]	width [mm]	width [mm]	Front	Rear	Front	Rear
	3000	1600	335	400	-	Up	-	-	-

·  : Rating over-front

·  : Rating over-side or 360 degree











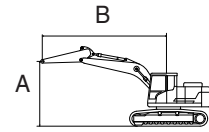



Load point height		Load radius								At max. reach		
		2.0 m (6.6 ft)		3.0 m (9.8 ft)		4.0 m (13.1 ft)		5.0 m (16.4 ft)		Capacity		Reach
												m (ft)
4.0 m (13.1 ft)	kg					*1240	1060			1170	950	4.26
	lb					*2730	2340			2580	2090	(14.0)
3.0 m (9.8 ft)	kg					*1290	1050			940	760	4.87
	lb					*2840	2310			2070	1680	(16.0)
2.0 m (6.6 ft)	kg			1950	1540	1250	1000	880	710	840	670	5.17
	lb			4300	3400	2760	2200	1940	1570	1850	1480	(17.0)
1.0 m (3.3 ft)	kg			1830	1420	1200	960	860	690	800	650	5.24
	lb			4030	3130	2650	2120	1900	1520	1760	1430	(17.2)
Ground Line	kg			1770	1370	1160	920	850	680	830	660	5.08
	lb			3900	3020	2560	2030	1870	1500	1830	1460	(16.7)
-1.0 m (-3.3 ft)	kg	*3100	2600	1760	1360	1150	910			930	750	4.66
	lb	*6830	5730	3880	3000	2540	2010			2050	1650	(15.3)
-2.0 m (-6.6 ft)	kg	*3640	2650	1790	1390					1220	970	3.89
	lb	*8020	5840	3950	3060					2690	2140	(12.8)
-3.0 m (-9.8 ft)	kg											
	lb											

Type	Boom	Arm	Counterweight	Shoe	Wheel	Dozer		Outrigger	
MONO BOOM	Length [mm]	Length [mm]	weight [kg]	width [mm]	width [mm]	Front	Rear	Front	Rear
	3000	1900	335	400	-	Down	-	-	-

•  : Rating over-front

•  : Rating over-side or 360 degree



Load point height		Load radius										At max. reach				
		1.0 m (3.3 ft)		2.0 m (6.6 ft)		3.0 m (9.8 ft)		4.0 m (13.1 ft)		5.0 m (16.4 ft)		Capacity		Reach		
															m (ft)	
5.0 m (16.4 ft)	kg lb												*1210 *2670	*1210 *2670	3.64 (11.9)	
4.0 m (13.1 ft)	kg lb							*1070 *2360	*1070 *2360					*1090 *2400	920 2030	4.63 (15.2)
3.0 m (9.8 ft)	kg lb							*1150 *2540	*1150 *2540	*1180 *2600	800 1760			*1030 *2270	750 1650	5.19 (17.0)
2.0 m (6.6 ft)	kg lb					*1750 *3860	1730 3810	*1400 *3090	1110 2450	*1250 *2760	790 1740			*1040 *2290	680 1500	5.47 (18.0)
1.0 m (3.3 ft)	kg lb					*2460 *5420	1600 3530	*1690 *3730	1060 2340	*1380 *3040	770 1700			*1100 *2430	660 1460	5.53 (18.2)
Ground Line	kg lb			*1490 *3280	*1490 *3280	*2840 *6260	1530 3370	*1910 *4210	1020 2250	*1460 *3220	750 1650			*1230 *2710	670 1480	5.38 (17.7)
-1.0 m (-3.3 ft)	kg lb	*1930 *4250	*1930 *4250	*2720 *6000	*2720 *6000	*2850 *6280	1510 3330	*1940 *4280	1000 2200					*1400 *3090	740 1630	5.00 (16.4)
-2.0 m (-6.6 ft)	kg lb	*3150 *6940	*3150 *6940	*4120 *9080	2970 6550	*2510 *5530	1530 3370	*1690 *3730	1010 2230					*1460 *3220	920 2030	4.30 (14.1)
-3.0 m (-9.8 ft)	kg lb			*2480 *5470	*2480 *5470	*1440 *3170	*1440 *3170							*1430 *3150	*1430 *3150	3.01 (9.9)









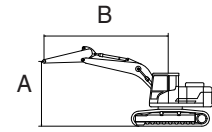





Type	Boom	Arm	Counterweight	Shoe	Wheel	Dozer		Outrigger	
MONO BOOM	Length [mm]	Length [mm]	weight [kg]	width [mm]	width [mm]	Front	Rear	Front	Rear
	3000	1900	335	400	-	Up	-	-	-

•  : Rating over-front

•  : Rating over-side or 360 degree



Load point height		Load radius										At max. reach			
		1.0 m (3.3 ft)		2.0 m (6.6 ft)		3.0 m (9.8 ft)		4.0 m (13.1 ft)		5.0 m (16.4 ft)		Capacity		Reach	
															m (ft)
5.0 m (16.4 ft)	kg lb												*1210 *2670	*1210 *2670	3.64 (11.9)
4.0 m (13.1 ft)	kg lb							*1070 *2360	*1070 *2360				1030 2270	840 1850	4.63 (15.2)
3.0 m (9.8 ft)	kg lb							*1150 *2540	1060 2340	910 2010	740 1630	850 1870	690 1520	5.19 (17.0)	
2.0 m (6.6 ft)	kg lb					*1750 *3860	1570 3460	1260 2780	1020 2250	890 1960	720 1590	770 1700	620 1370	5.47 (18.0)	
1.0 m (3.3 ft)	kg lb					1860 4100	1450 3200	1210 2670	970 2140	870 1920	700 1540	740 1630	600 1320	5.53 (18.2)	
Ground Line	kg lb			*1490 *3280	*1490 *3280	1790 3950	1380 3040	1170 2580	930 2050	850 1870	680 1500	760 1680	610 1340	5.38 (17.7)	
-1.0 m (-3.3 ft)	kg lb	*1930 *4250	*1930 *4250	*2720 *6000	2590 5710	1760 3880	1360 3000	1150 2540	910 2010			840 1850	670 1480	5.00 (16.4)	
-2.0 m (-6.6 ft)	kg lb	*3150 *6940	*3150 *6940	3670 8090	2630 5800	1780 3920	1380 3040	1160 2560	920 2030			1050 2310	840 1850	4.30 (14.1)	
-3.0 m (-9.8 ft)	kg lb			*2480 *5470	*2480 *5470	*1440 *3170	*1440 *3170					*1430 *3150	*1430 *3150	3.01 (9.9)	

## 6. BUCKET SELECTION GUIDE

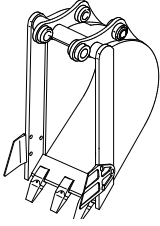
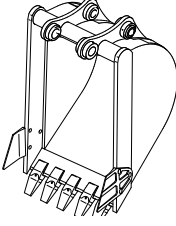
	
<p>0.07m<sup>3</sup> SAE heaped bucket</p>	<p>0.18 m<sup>3</sup> SAE heaped bucket</p>

Capacity		Width		Weight	Recommendation
					3.0 m (9' 10") boom
SAE heaped	CECE heaped	Without side cutter	With side cutter		1.6 m (5' 3") arm
0.07 m <sup>3</sup> (0.09 yd <sup>3</sup> )	0.06 m <sup>3</sup> (0.08 yd <sup>3</sup> )	315 mm (12.4")	360 mm (14.2")	115 kg (255 lb)	Applicable for materials with density of 1600 kgf/m <sup>3</sup> (2700 lb/yd <sup>3</sup> ) or less
0.18 m <sup>3</sup> (0.24 yd <sup>3</sup> )	0.15 m <sup>3</sup> (0.20 yd <sup>3</sup> )	670 mm (26.4")	740 mm (29.1")	170 kg (375 lb)	

## 7. UNDERCARRIAGE

### 1) TRACKS

X-leg type center frame is integrally welded with reinforced box-section track frames. The design includes dry tracks, lubricated rollers, idlers, sprockets, hydraulic track adjusters with shock absorbing springs and assembled track-type tractor shoes with triple grousers.

### 2) TYPES OF SHOES

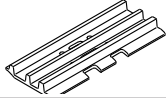
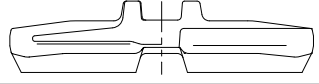
Model	Shapes		Triple grouser	Rubber shoe
				
R55-9A	Shoe width	mm (in)	380 (15)	400 (16)
	Operating weight	kg (lb)	5650 (12460)	5670 (12500)
	Ground pressure	kgf/cm <sup>2</sup> (psi)	0.34 (4.83)	0.33 (4.69)
	Overall width	mm (ft-in)	1880 (6' 2")	1900 (6' 3")

### 3) NUMBER OF ROLLERS AND SHOES ON EACH SIDE

Item	Quantity
Carrier rollers	1 EA
Track rollers	5 EA
Track shoes (steel)	40 EA

## 8. SPECIFICATIONS FOR MAJOR COMPONENTS

### 1) ENGINE

Item	Specification
Model	Yanmar 4TNV98C
Type	4-cycle diesel engine, low emission
Cooling method	Water cooling
Number of cylinders and arrangement	4 cylinders, in-line
Firing order	1-3-4-2
Combustion chamber type	Direct injection type
Cylinder borexstroke	98 × 110 mm (3.85" × 4.33")
Piston displacement	3319 cc (203 cu in)
Compression ratio	18.5 : 1
Rated gross horse power (SAE J1995)	66.9 Hp at 2400 rpm (49.9 kW at 2400 rpm)
Maximum torque at 1550 rpm	24 kgf · m (173.6 lbf · ft)
Engine oil quantity	11.6 ℓ (3.1 U.S. gal)
Dry weight	270 kg (595 lb)
High idling speed	2300+50 rpm
Low idling speed	1000 ± 100 rpm
Rated fuel consumption	176 g/Hp · hr at 2400 rpm
Starting motor	12 V-3.0 kW
Alternator	12 V-60 A
Battery	1 × 12 V × 100 Ah

### 2) MAIN PUMP

Item	Specification
Type	Variable displacement tandem axis piston pumps
Capacity	2 × 27.5 cc/rev
Maximum pressure	220 kgf/cm <sup>2</sup> (3130 psi)
Rated oil flow	2 × 57.8 ℓ /min (15.3 U.S. gpm / 12.7 U.K. gpm)
Rated speed	2100 rpm

### 3) GEAR PUMP

Item	Specification
Type	Fixed displacement gear pump single stage
Capacity	18.3 + 4.5 cc/rev
Maximum pressure	220/30 kgf/cm <sup>2</sup> (3130/430 psi)
Rated oil flow	38.4/9.5 ℓ /min (10.1/2.5 U.S. gpm / 8.4/2.1 U.K. gpm)

### 4) MAIN CONTROL VALVE

Item	Specification
Type	Sectional, 9 spools
Operating method	Hydraulic pilot system
Main relief valve pressure	220 kgf/cm <sup>2</sup> (3130 psi)
Overload relief valve pressure	240 kgf/cm <sup>2</sup> (3410 psi)

### 5) SWING MOTOR

Item	Specification
Type	Fixed displacement axial piston motor
Capacity	32.3 cc/rev
Relief pressure	220 kgf/cm <sup>2</sup> (3130 psi)
Braking system	Automatic, spring applied hydraulic released
Braking torque	14 kgf · m (101 lbf · ft)
Brake release pressure	20~40 kgf/cm <sup>2</sup> (284~570 psi)
Reduction gear type	2 - stage planetary

### 6) TRAVEL MOTOR

Item	Specification
Type	Variable displacement axial piston motor
Relief pressure	220 kgf/cm <sup>2</sup> (3130 psi)
Reduction gear type	2-stage planetary
Braking system	Automatic, spring applied hydraulic released
Brake release pressure	9 kgf/cm <sup>2</sup> (128 psi)
Braking torque	8.4 kgf · m (61 lbf · ft)

## 7) CYLINDER

Item		Specification
Boom cylinder	Bore dia × Rod dia × Stroke	Ø 110 × Ø 65 × 715 mm
	Cushion	Extend only
Arm cylinder	Bore dia × Rod dia × Stroke	Ø 90 × Ø 55 × 850 mm
	Cushion	Extend and retract
Bucket cylinder	Bore dia × Rod dia × Stroke	Ø 80 × Ø 50 × 660 mm
	Cushion	Extend only
Dozer blade	Bore dia × Rod dia × Stroke	Ø 110 × Ø 60 × 219 mm
	Cushion	Extend only

※ Discoloration of cylinder rod can occur when the friction reduction additive of lubrication oil spreads on the rod surface.

※ Discoloration does not cause any harmful effect on the cylinder performance.

## 8) SHOE

Item		Width	Ground pressure	Link quantity	Overall width
R55-9A	Steel	380 mm (15")	0.34 kgf/cm <sup>2</sup> (4.83 psi)	40	1880 mm (6' 2")
	Rubber	400 mm (16")	0.33 kgf/cm <sup>2</sup> (4.69 psi)	-	1900 mm (6' 3")

## 9) BUCKET

Item		Capacity		Tooth quantity	Width	
		SAE heaped	CECE heaped		Without side cutter	With side cutter
R55-9A	STD	0.18 m <sup>3</sup> (0.24 yd <sup>3</sup> )	0.15 m <sup>3</sup> (0.20 yd <sup>3</sup> )	5	670 mm (26.4")	740 mm (29.1")
	OPT	0.07 m <sup>3</sup> (0.09 yd <sup>3</sup> )	0.06 m <sup>3</sup> (0.08 yd <sup>3</sup> )	3	315 mm (12.4")	360 mm (14.2")

## 9. RECOMMENDED OILS

HYUNDAI genuine lubricating oils have been developed to offer the best performance and service life for your equipment. These oils have been tested according to the specifications of HYUNDAI and, therefore, will meet the highest safety and quality requirements.

We recommend that you use only HYUNDAI genuine lubricating oils and grease officially approved by HYUNDAI.

Service point	Kind of fluid	Capacity ℓ (U.S. gal)	Ambient temperature °C (°F)						
			-50 (-58)	-30 (-22)	-20 (-4)	-10 (14)	0 (32)	10 (50)	20 (68)
Engine oil pan	Engine oil	11.6 (3.1)	★SAE 5W-40						
			SAE 30						
			SAE 10W						
			SAE 10W-30						
			SAE 15W-40						
Swing drive	Grease	0.2 (0.1)	★NLGI NO.1						
			NLGI NO.2						
Final drive	Gear oil	1.5 (0.4)	★SAE 75W-90						
		1.2×2 (0.3×2)	SAE 80W-90						
Hydraulic tank	Hydraulic oil	Tank; 70 (18.5)	★ISO VG 15						
			ISO VG 32						
		System; 120 (31.7)	ISO VG 46, HBHO VG 46★ <sup>3</sup>						
			ISO VG 68						
Fuel tank	Diesel fuel★ <sup>1</sup>	120 (31.7)	★ASTM D975 NO.1						
			ASTM D975 NO.2						
Fitting (grease nipple)	Grease	As required	★NLGI NO.1						
			NLGI NO.2						
Radiator (reservoir tank)	Mixture of antifreeze and water 50 : 50★ <sup>2</sup>	9.5 (2.5)	Ethylene glycol base permanent type						
			★Ethylene glycol base permanent type (60 : 40)						

**SAE** : Society of Automotive Engineers

**API** : American Petroleum Institute

**ISO** : International Organization for Standardization

**NLGI** : National Lubricating Grease Institute

**ASTM** : American Society of Testing and Material

**UTTO** : Universal Tractor Transmission Oil

★ : Cold region

Russia, CIS, Mongolia

★<sup>1</sup> : Ultra low sulfur diesel

- sulfur content ≤ 15 ppm

★<sup>2</sup> : Soft water

City water or distilled water

★<sup>3</sup> : Hyundai Bio Hydraulic Oil

- For more information, contact HYUNDAI dealers.

※ Using any lubricating oils other than HYUNDAI genuine products may lead to a deterioration of performance and cause damage to major components.

※ Do not mix HYUNDAI genuine oil with any other lubricating oil as it may result in damage to the systems of major components.

※ Do not use any engine oil other than that specified above, as it may clog the diesel particulate filter(DPF).

※ For HYUNDAI genuine lubricating oils and grease for use in regions with extremely low temperatures, please contact HYUNDAI dealers.