

GROUP 3 TRACK AND WORK EQUIPMENT

1. TRACK SHOE

1) STEEL SHOE SPEC

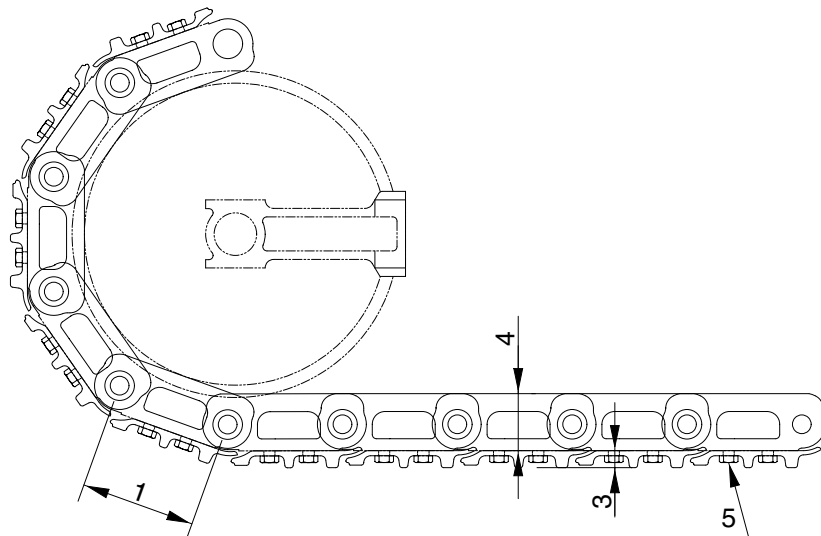
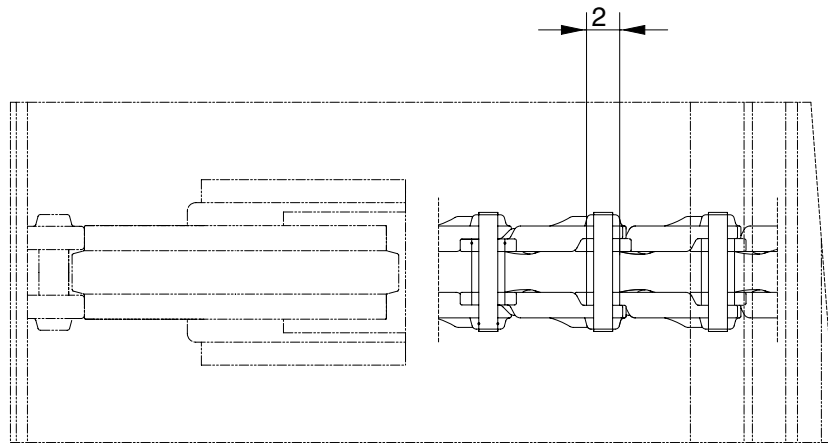

R5576MC16

Unit : mm

No	Check item	Criteria		Remedy
		Standard size	Repair limit	
1	Link pitch	135	138.6	Replace bushing and pin and link assembly
2	Outside diameter of bushing	35	31.4	
3	Height of grouser	14	11	Lug welding, rebuild or replace
4	Height of link	67	61.5	
5	Tightening torque	Initial tightening torque : $19 \pm 1.0 \text{kgf} \cdot \text{m}$		Retighten

2) RUBBER SHOE SPEC

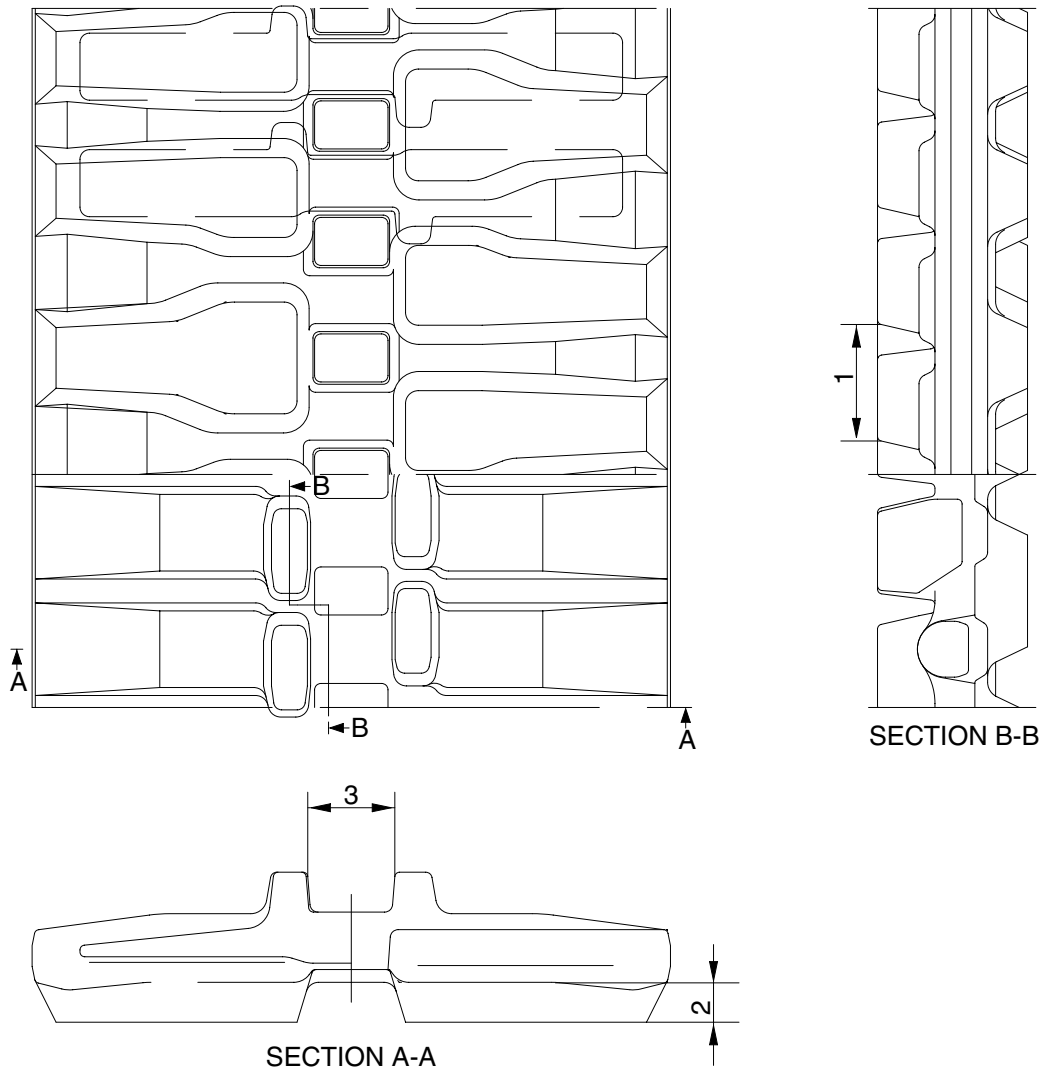

R5576MC17

Unit : mm

No	Check item	Criteria			Remedy
		Standard size	Tolerance	Repair limit	
1	Link pitch	73	± 1.0	76	Replace
2	Height of grouser	25	-	5	
3	Width of link	55	-	70	

2. IDLER

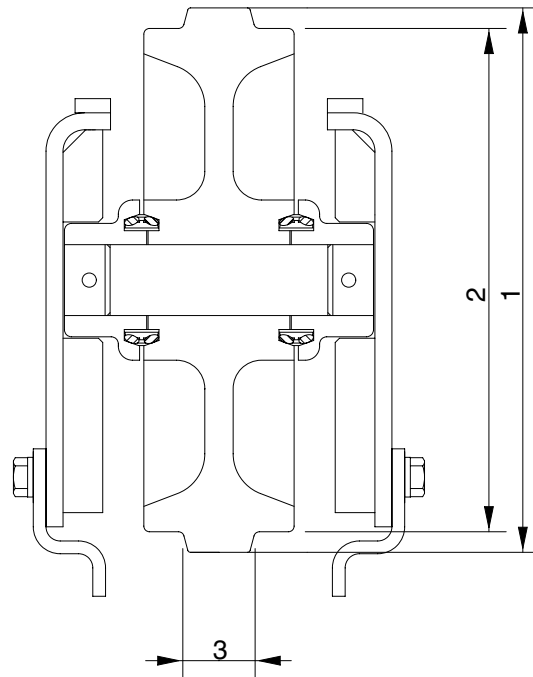

R5576MC18

Unit : mm

No	Check item		Criteria		Remedy
			Standard size	Repair limit	
1	Outside diameter of flange	Steel	384	-	Rebuild or replace
		Rubber	398	-	
2	Outside diameter of thread		355	345	
3	Width of flange		51	-	

3. TRACK/CARRIER ROLLER

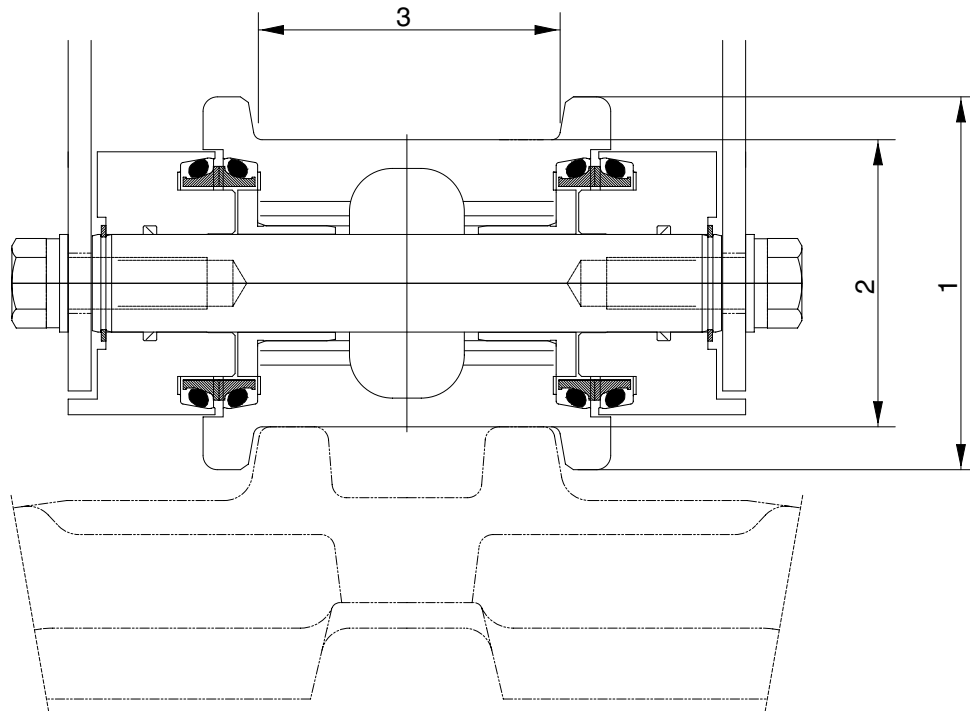

R5576MC15

Unit : mm

No	Check item		Criteria		Remedy
			Standard size	Repair limit	
1	Outside diameter of flange	Steel	130	-	Rebuild or replace
		Rubber	135	-	
2	Outside diameter of thread		105	95	
3	Width of flange		108	114	

4. TENSION CYLINDER

1) STEEL SHOE SPEC

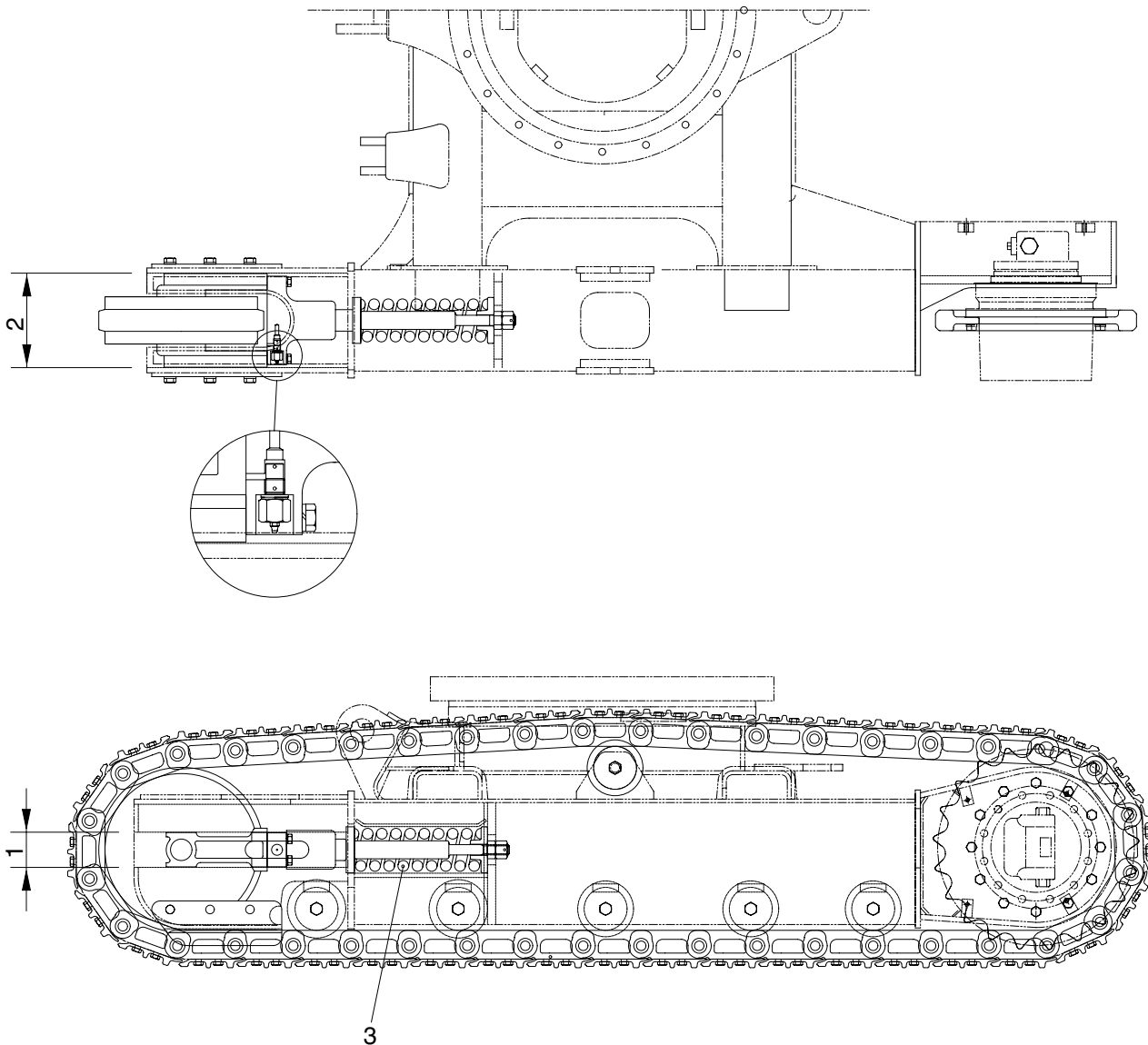

R5576MC19

Unit : mm

No	Check item	Criteria			Remedy		
			Standard size	Repair limit			
1	Vertical width of idler guide	Track frame	82	86	Rebuild		
		Idler support	80	78	Rebuild or replace		
2	Horizontal width of idler guide	Track frame	220	222	Rebuild		
		Idler guide	218	214	Rebuild or replace		
3	Recoil spring	Standard size		Repair limit		Replace	
		Free length	Installed length	Installed load	Free length		Installed load
		∅ 100 × 330	292	3,900 kg	-		3,120 kg

2) RUBBER SHOE SPEC

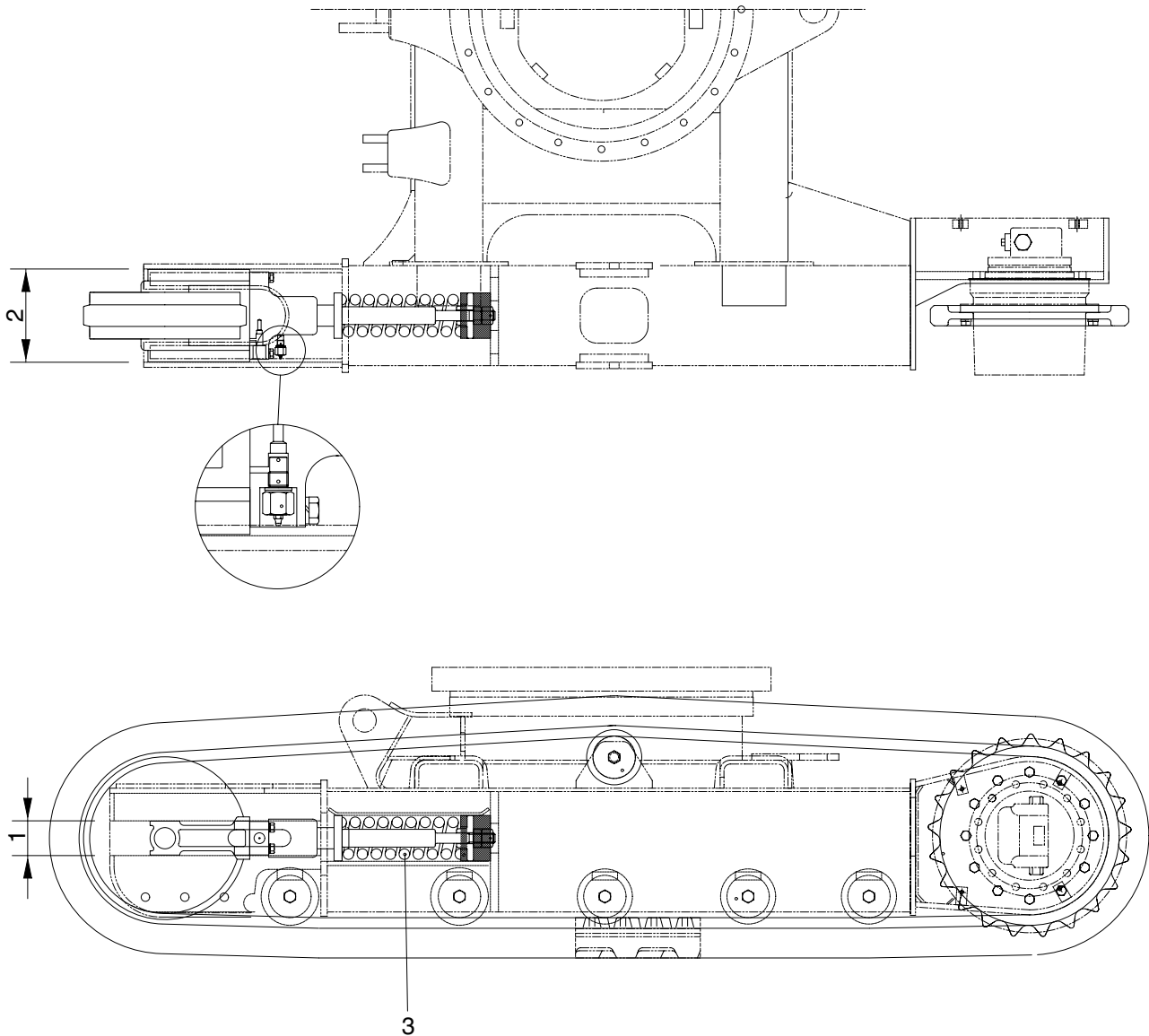

R5576MC20

Unit : mm

No	Check item	Criteria				Remedy	
			Standard size	Repair limit			
1	Vertical width of idler guide	Track frame	82	86		Rebuild	
		Idler support	80	76			
2	Horizontal width of idler guide	Track frame	220	222		Rebuild or replace	
		Idler guide	218	214		Rebuild	
3	Recoil spring	Standard size			Repair limit		Rebuild or replace
		Free length	Installed length	Installed load	Free length	Installed load	
		330	280	5,140 kg	-	4,110 kg	Replace

5. SPROCKET

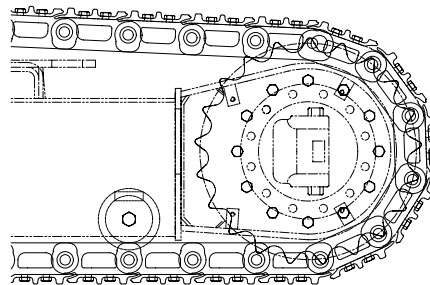
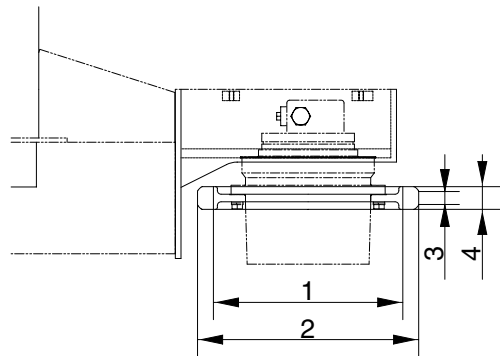

R5576MC21

Unit : mm

No	Check item	Criteria		Remedy
		Standard size	Repair limit	
1	Wear out of sprocket tooth lower side diameter	418.6	412	Repair or Replace
2	Wear out of sprocket tooth upper side diameter	476	-	
3	Wear out of sprocket tooth upper side width	33.5	-	
4	Wear out of sprocket tooth lower side width	42.5	36.5	

6. WORK EQUIPMENT

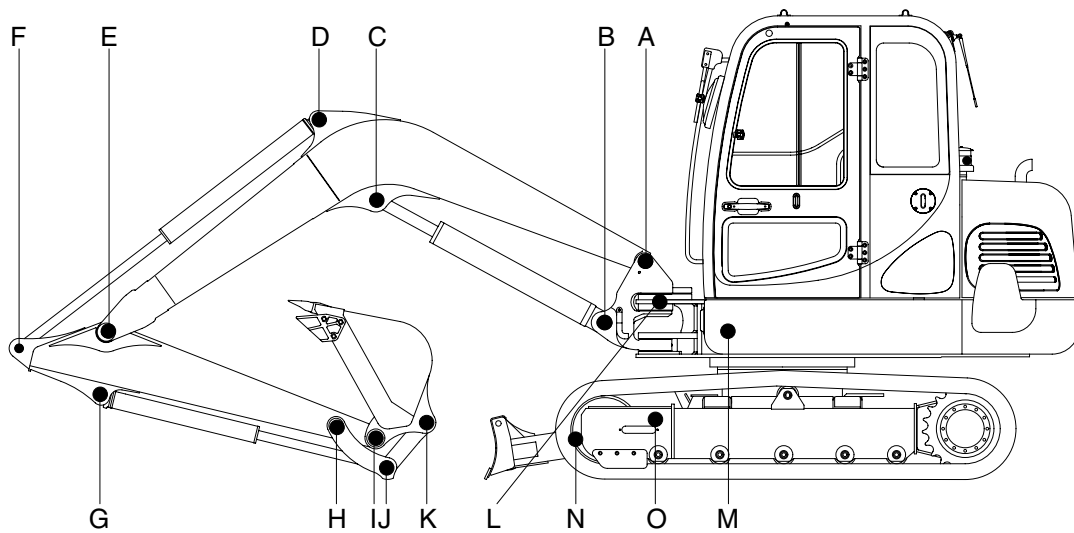

R5576MC30

Unit : mm

Mark	Measuring point (Pin and Bushing)	Normal value	Pin		Bushing		Remedy & Remark
			Recomm. service limit	Limit of use	Recomm. service limit	Limit of use	
A	Boom Rear	50	49	48.5	50.5	51	Replace
B	Boom Cylinder Head	60	59	58.5	60.5	61	"
C	Boom Cylinder Rod	60	59	58.5	60.5	61	"
D	Arm Cylinder Head	50	49	48.5	50.5	51	"
E	Boom Front	50	49	48.5	50.5	51	"
F	Arm Cylinder Rod	50	49	48.5	50.5	51	"
G	Bucket Cylinder Head	45	44	43.5	45.5	46	"
H	Arm Link	45	44	43.5	45.5	46	"
I	Bucket and Arm Link	45	44	43.5	45.5	46	"
J	Bucket Cylinder Rod	45	44	43.5	45.5	46	"
K	Bucket Link	45	44	43.5	45.5	46	"
L	Boom swing post	110	109	108.5	110.5	111	"
M	Boom swing cylinder	50	49	48.5	50.5	51	"
N	Blade cylinder	55	54	53.5	55.5	56	"
O	Blade and frame link	35	34	33.5	35.5	36	"