

GROUP 9 BOOM, ARM AND BUCKET CYLINDERS

1. REMOVAL AND INSTALL

1) BUCKET CYLINDER

(1) Removal

- ※ Expand the arm and bucket fully, lower the work equipment to the ground and stop the engine.
- ※ Operate the control levers and pedals several times to release the remaining pressure in the hydraulic piping.

▲ Loosen the breather slowly to release the pressure inside the hydraulic tank. Escaping fluid under pressure can penetrate the skin causing serious injury.

- ※ Fit blind plugs in the hoses after disconnecting them, to prevent dirt or dust from entering.

① Set block between bucket cylinder and arm.

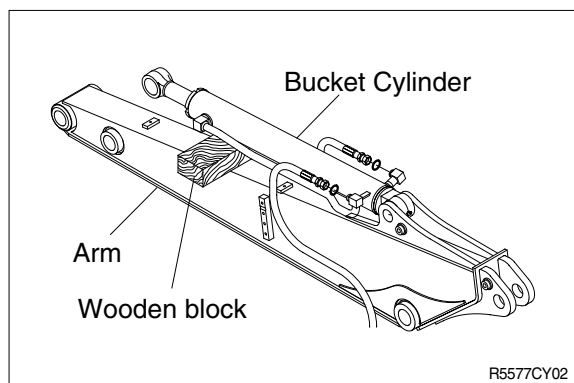

② Remove bolt(2), nut(3) and pull out pin (1).

- ※ Tie the rod with wire to prevent it from coming out.

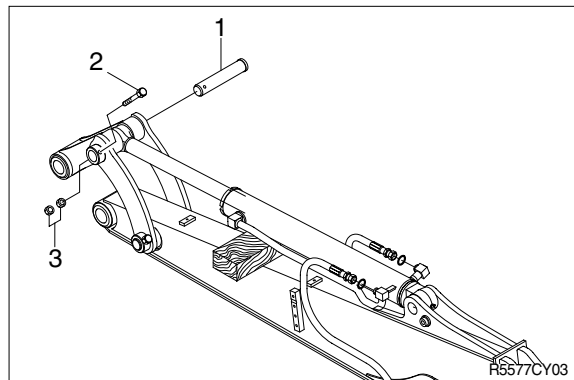

③ Disconnect bucket cylinder hoses(4) and put plugs(5) on cylinder pipe.

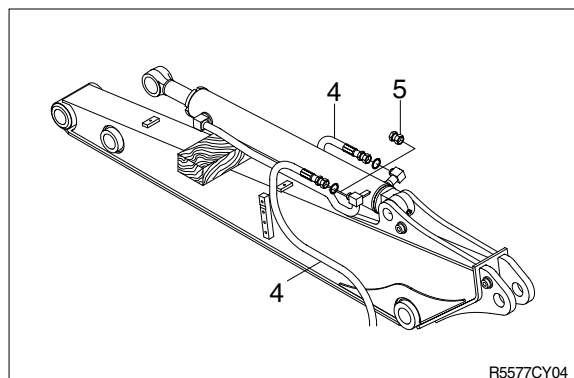

- ④ Sling bucket cylinder assembly(8) and remove bolt(6) then pull out pin (5).
- ⑤ Remove bucket cylinder assembly(8).
 - Weight : 30kg(70lb)

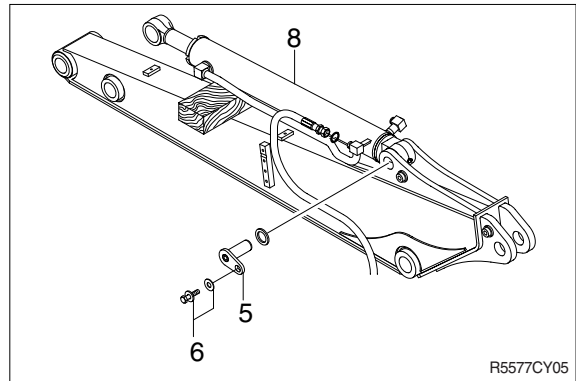

(2) Install

- ① Carry out installation in the reverse order to removal.
- ▲ When aligning the mounting position of the pin, do not insert your fingers in the pin hole.**
- ※ Bleed the air from the bucket cylinder.
 - ※ Confirm the hydraulic oil level and check the hydraulic oil leak or not.

2) ARM CYLINDER

(1) Removal

- ※ Expand the arm and bucket fully, lower the work equipment to the ground and stop the engine.
- ※ Operate the control levers and pedals several times to release the remaining pressure in the hydraulic piping.

▲ Loosen the breather slowly to release the pressure inside the hydraulic tank.

▲ Escaping fluid under pressure can penetrate the skin causing serious injury.

- ※ Fit blind plugs in the hoses after disconnecting them, to prevent dirt or dust from entering.

① Set block between arm cylinder and boom.

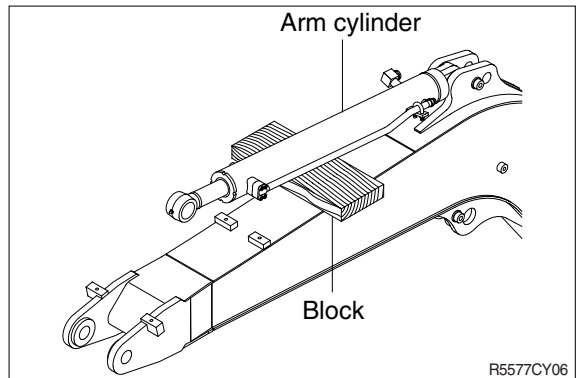

② Remove bolt(2) and pull out pin(1).

- ※ Tie the rod with wire to prevent it from coming out.

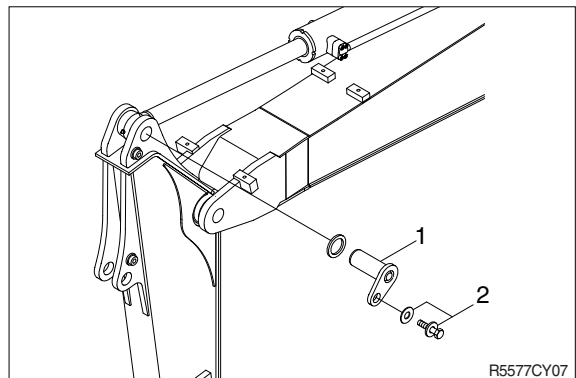

③ Disconnect arm cylinder hoses(4) and put plugs on cylinder pipe.

④ Disconnect greasing pipings(5).

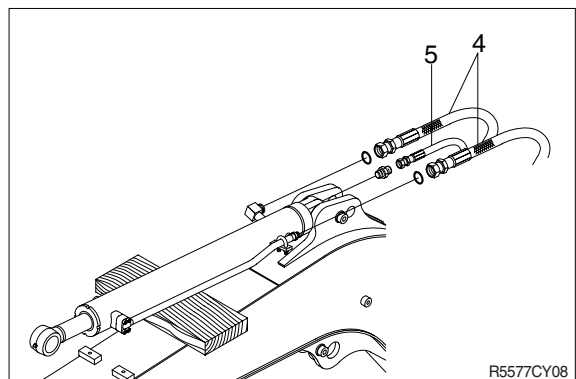

- ⑤ Sling arm assembly(8) and remove bolt (7) then pull out pin(6).
- ⑥ Remove arm cylinder assembly(8).
 - Weight : 50kg(110lb)

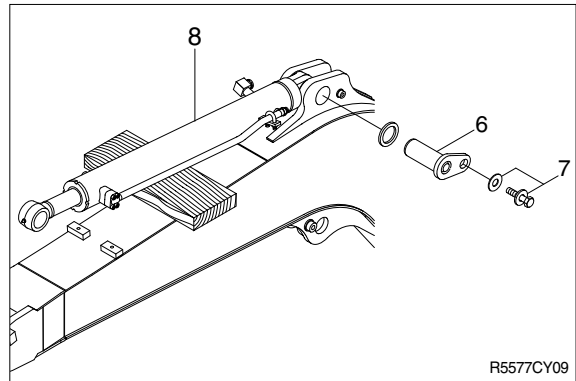

(2) Install

- ① Carry out installation in the reverse order to removal.
- ▲ When aligning the mounting position of the pin, do not insert your fingers in the pin hole.**
- ※ Bleed the air from the arm cylinder.
 - ※ Confirm the hydraulic oil level and check the hydraulic oil leak or not.

3) BOOM CYLINDER

(1) Removal

- ※ Expand the arm and bucket fully, lower the work equipment to the ground and stop the engine.
- ※ Operate the control levers and pedals several times to release the remaining pressure in the hydraulic piping.

▲ Loosen the breather slowly to release the pressure inside the hydraulic tank.

▲ Escaping fluid under pressure can penetrate the skin causing serious injury.

- ※ Fit blind plugs in the hoses after disconnecting them, to prevent dirt or dust from entering.

① Sling boom cylinder assembly.

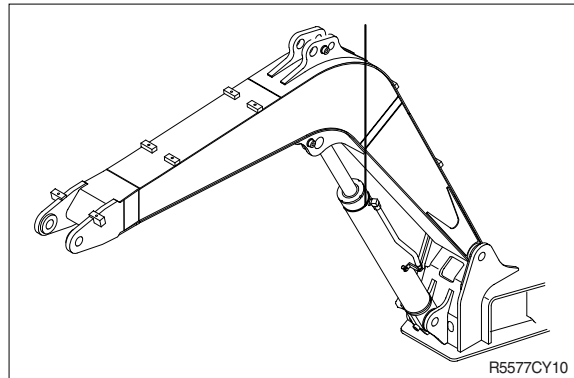

③ Remove bolt(2) and pull out pin(1).

- ※ Tie the rod with wire to prevent it from coming out.

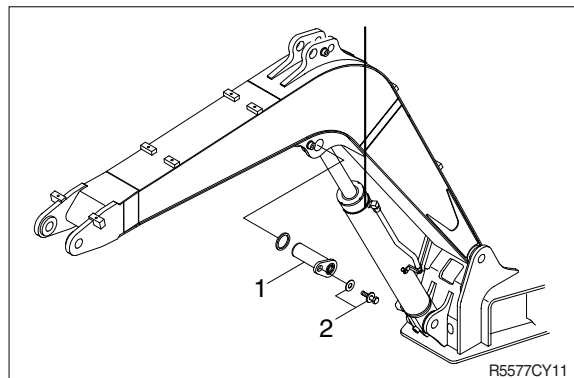

④ Lower the boom cylinder assembly(3) on a stand.

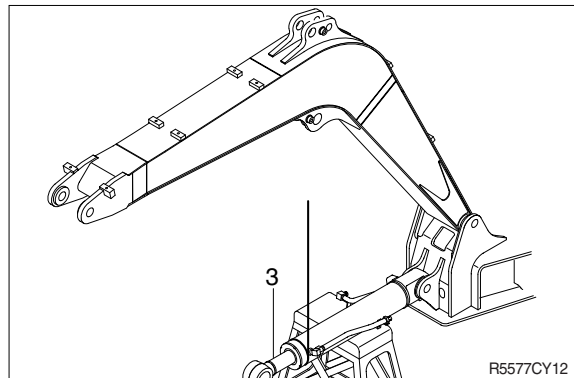

- ⑤ Disconnect boom cylinder hoses(4) and put plugs on cylinder pipe.

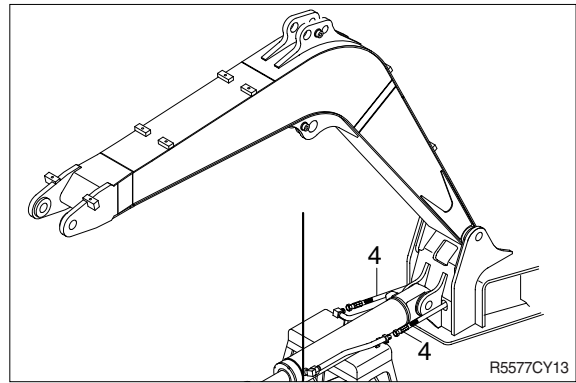

- ⑥ Remove bolt(6) and pull out pin(5).
⑦ Remove boom cylinder assembly(3).
· Weight : 60kg(130lb)

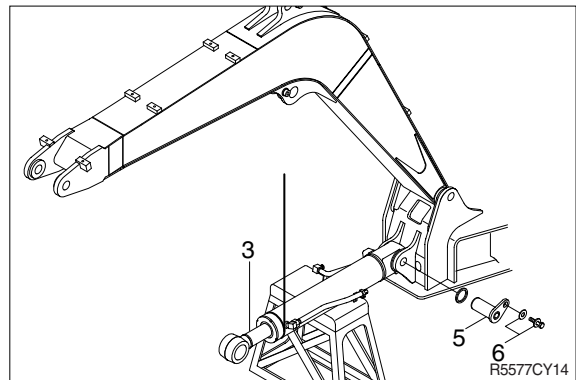

(2) Install

- ① Carry out installation in the reverse order to removal.

▲ When aligning the mounting position of the pin, do not insert your fingers in the pin hole.

- ※ Bleed the air from the boom cylinder.
- ※ Confirmed the hydraulic oil level and check the hydraulic oil leak or not.

2. DISASSEMBLY AND ASSEMBLY

1) STRUCTURE

(1) Bucket cylinder

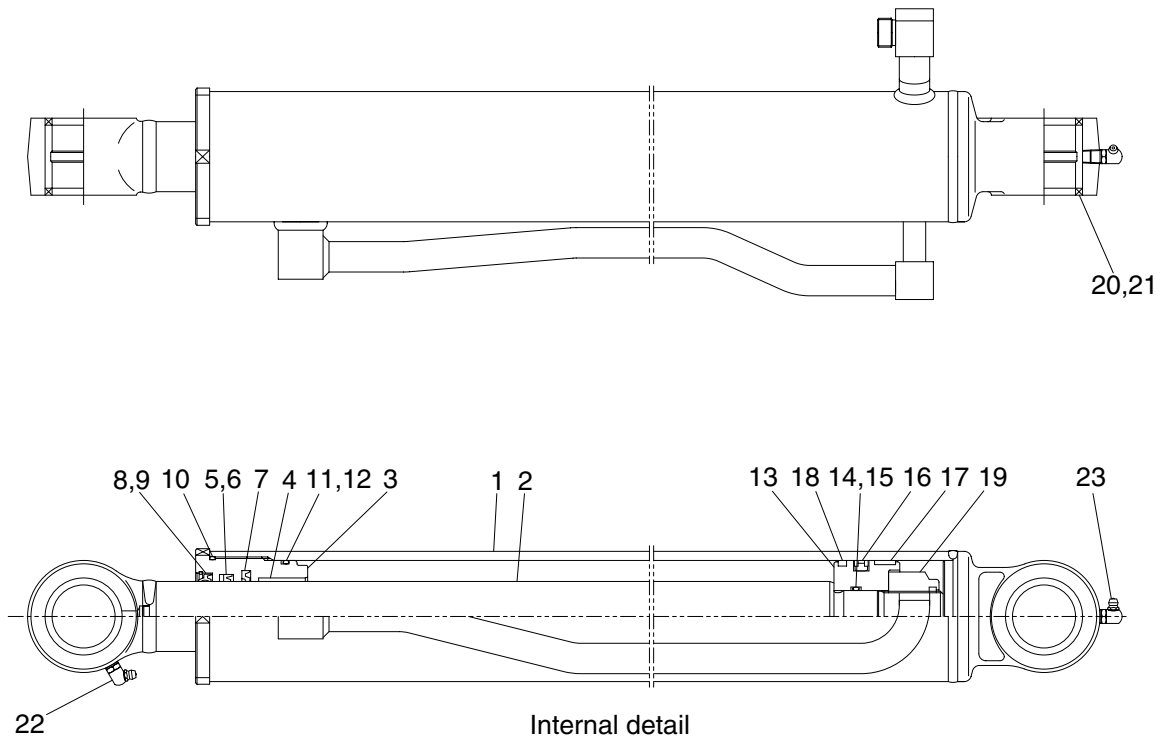

R5577CY22

1	Tube assembly	9	Snap ring	17	Wear ring
2	Rod assembly	10	O-ring	18	Dust ring
3	Gland	11	O-ring	19	Lock nut
4	Du bushing	12	Back-up ring	20	Pin bushing
5	Rod seal	13	Piston	21	Dust seal
6	Back-up ring	14	O-ring	22	Grease nipple
7	Buffer ring	15	Back-up ring	23	Grease nipple
8	Dust wiper	16	Piston seal		

(2) Arm cylinder

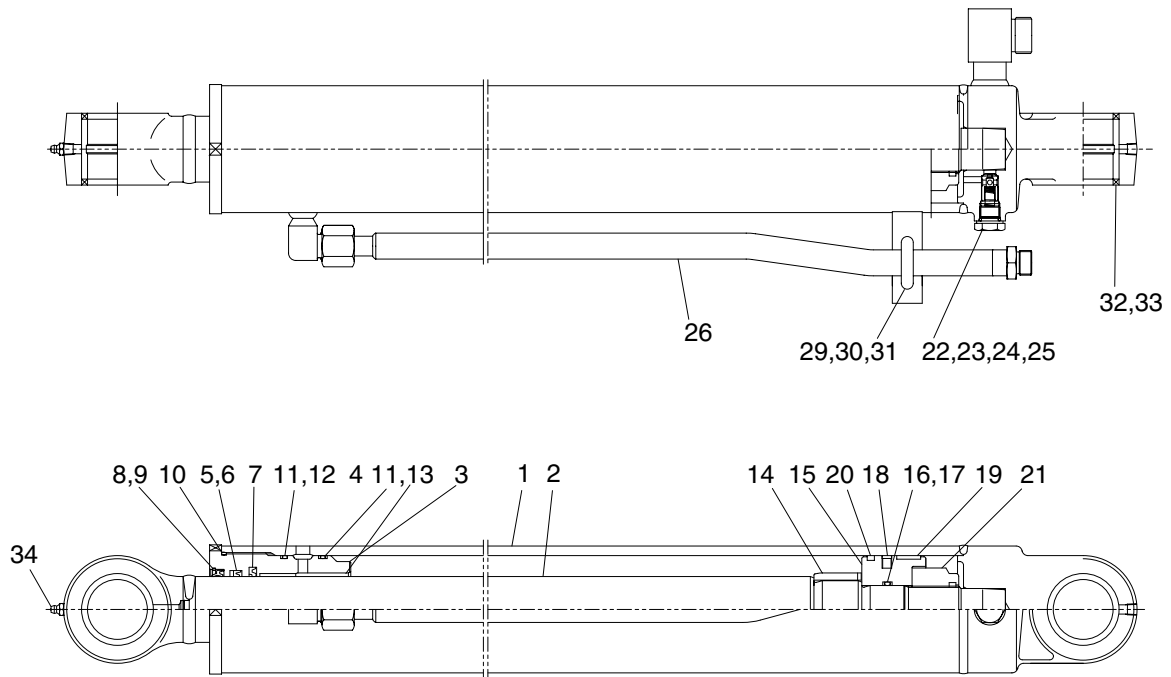

Internal detail

R5577CY24

1	Tube assembly	12	Back-up ring	23	Coil spring
2	Rod assembly	13	Back-up ring	24	O-ring
3	Gland	14	Cushion ring	25	Plug
4	DD2 bushing	15	Piston	26	Pipe assembly(R)
5	Rod seal	16	O-ring	29	U-bolt
6	Back-up ring	17	Back-up ring	30	Hexagon head nut
7	Buffer ring	18	Piston seal	31	Spring washer
8	Dust wiper	19	Wear ring	32	Pin bushing
9	Snap ring	20	Dust ring	33	Dust seal
10	O-ring	21	Lock nut	34	Grease nipple
11	O-ring	22	Check valve		

(3) Boom cylinder

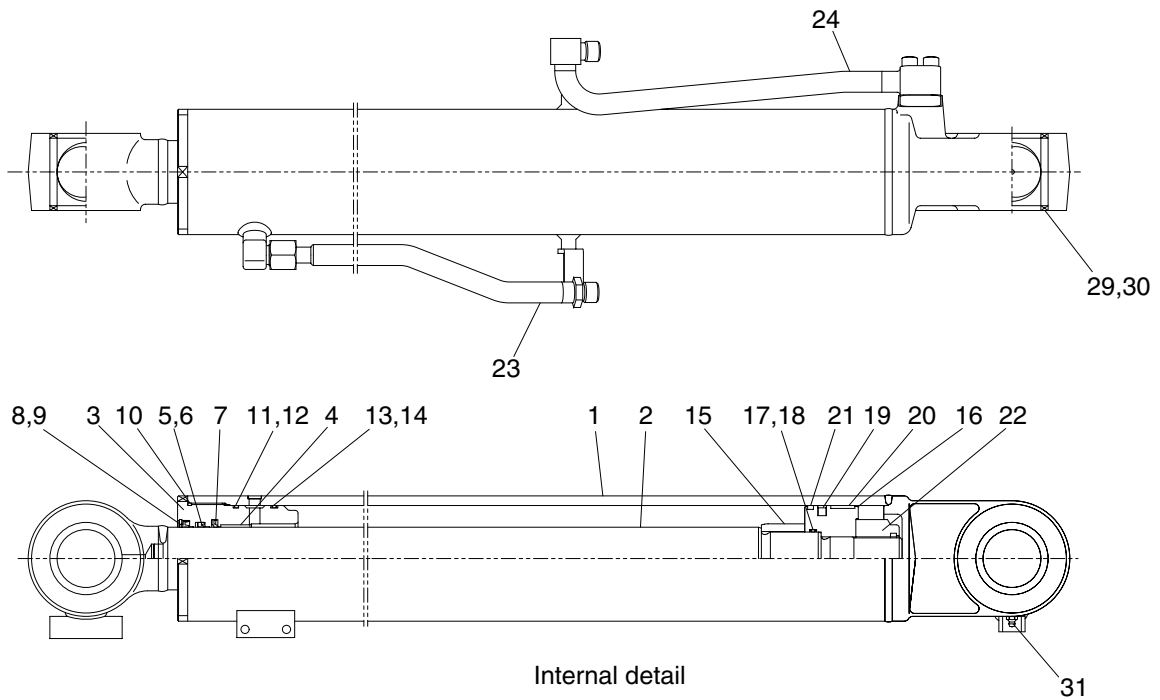

R5577CY21

1	Tube assembly	12	Buck-up ring	22	Lock nut
2	Rod assembly	13	O-ring	23	Pipe assembly(R)
3	Gland	14	Buck-up ring	24	Pipe assembly(B)
4	Du bushing	15	Cushion ring	25	O-ring
5	Rod seal	16	Piston	26	Socket head bolt
6	Buck-up ring	17	O-ring	27	Hexagon head bolt
7	Buffer ring	18	Buck-up ring	28	Plain washer
8	Dust wiper	19	Piston seal	29	Pin bushing
9	Snap ring	20	Wear ring	30	Dust seal
10	O-ring	21	Dust ring	31	Grease nipple
11	O-ring				

(4) Dozer cylinder

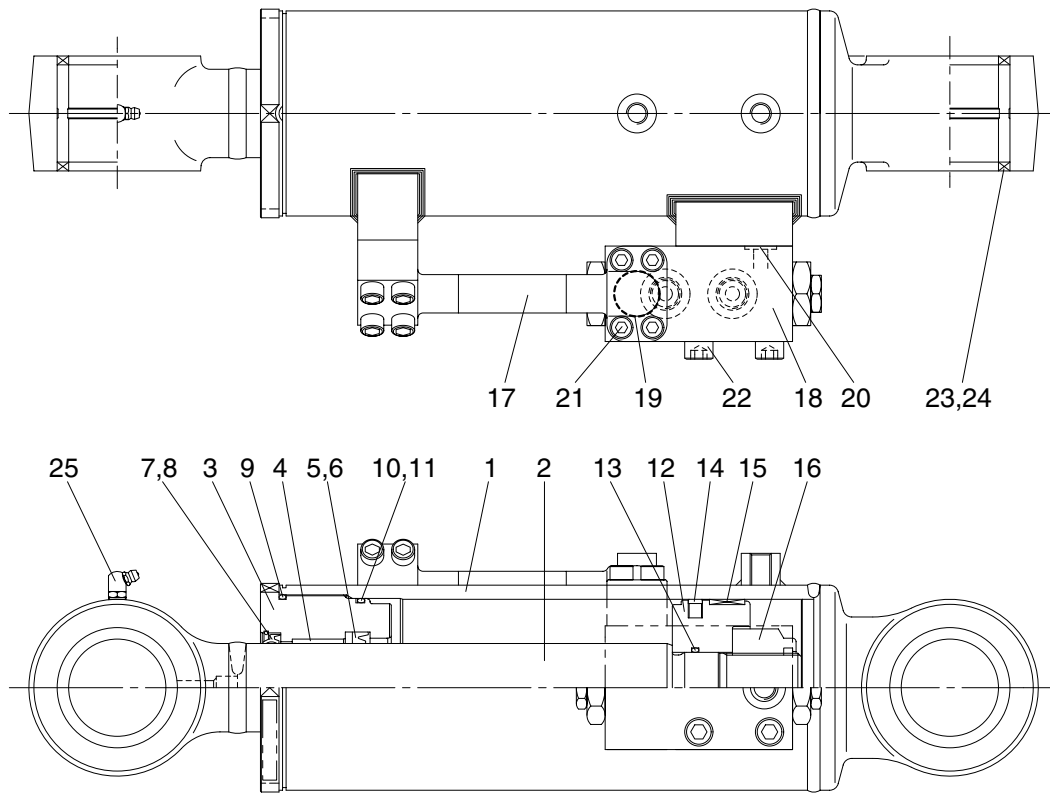

Internal detail

55W77CY23

- | | | | | | |
|---|---------------|----|------------------|----|--------------------|
| 1 | Tube assembly | 10 | O-ring | 18 | Double check valve |
| 2 | Rod assembly | 11 | Buck-up ring | 19 | O-ring |
| 3 | Gland | 12 | Piston | 20 | O-ring |
| 4 | Du bushing | 13 | O-ring | 21 | Socket head bolt |
| 5 | Rod seal | 14 | Piston seal | 22 | Socket head bolt |
| 6 | Buck-up ring | 15 | Wear ring | 23 | Pin bushing |
| 7 | Dust wiper | 16 | Lock nut | 24 | Dust seal |
| 8 | Snap ring | 17 | Pipe assembly(R) | 25 | Grease nipple |
| 9 | O-ring | | | | |

(5) Boom swing cylinder

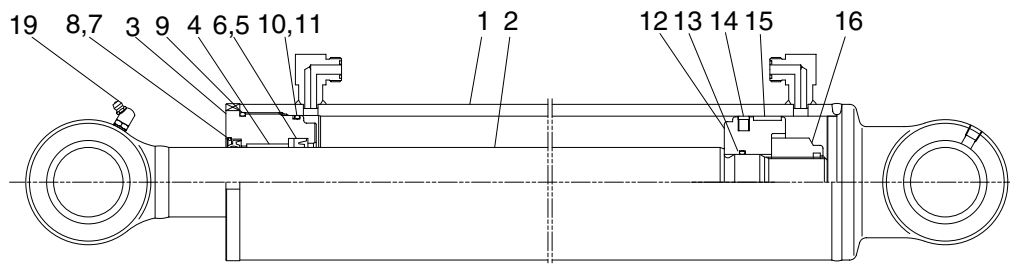
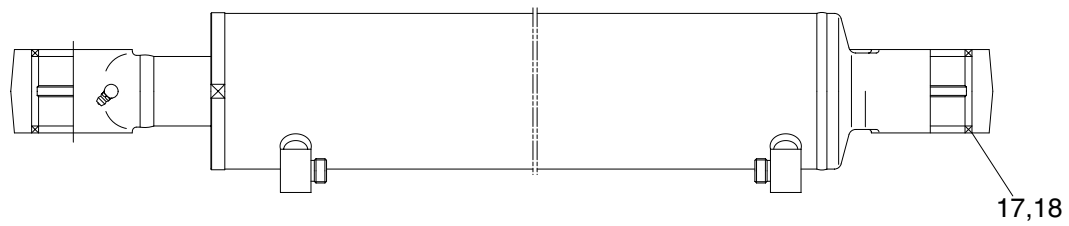

Internal details

R5577CY20

- | | | | | | |
|---|---------------|----|--------------|----|---------------|
| 1 | Tube assembly | 8 | Snap ring | 14 | Piston seal |
| 2 | Rod assembly | 9 | O-ring | 15 | Wear ring |
| 3 | Gland | 10 | O-ring | 16 | Lock nut |
| 4 | Du bushing | 11 | Buck-up ring | 17 | Pin bushing |
| 5 | Rod seal | 12 | Piston | 18 | Dust seal |
| 6 | Buck-up ring | 13 | O-ring | 19 | Grease nipple |
| 7 | Dust wiper | | | | |

2) TOOLS AND TIGHTENING TORQUE

(1) Tools

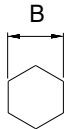
Name	Specification	
Allen wrench	8	
	10	
Spanner	M22	
Hook spanner	Suitable size	
(-) Driver	Small and large sizes	
Torque wrench	Capable of tightening with the specified torques	

(2) Tightening torque

Part name		Item	Size	Torque	
				kgf · m	lbf · ft
Gland	Boom cylinder	3	M115	95 ± 9.5	690 ± 69
	Arm cylinder	3	M95	80 ± 8.0	580 ± 58
	Bucket cylinder	3	M85	70 ± 7.0	510 ± 51
	Dozer cylinder	3	M105	75 ± 8.0	545 ± 58
	Boom swing cylinder	3	M105	75 ± 8.0	545 ± 58
Lock nut	Boom cylinder	22	M45	292 ± 29	2110 ± 211
	Arm cylinder	21	M39	190 ± 19	1375 ± 138
	Bucket cylinder	19	M36	150 ± 15	1085 ± 109
	Dozer cylinder	16	M39	190 ± 19	1375 ± 211
	Boom swing cylinder	16	M39	190 ± 19	1375 ± 138

3) DISASSEMBLY

(1) Remove cylinder head and piston rod

- ① Hold the clevis section of the tube in a vise.
- ※ Use mouth pieces so as not to damage the machined surface of the cylinder tube. Do not make use of the outside piping as a locking means.

- ② Pull out rod assembly(2) about 200mm (7.1in). Because the rod assembly is rather heavy, finish extending it with air pressure after the oil draining operation.

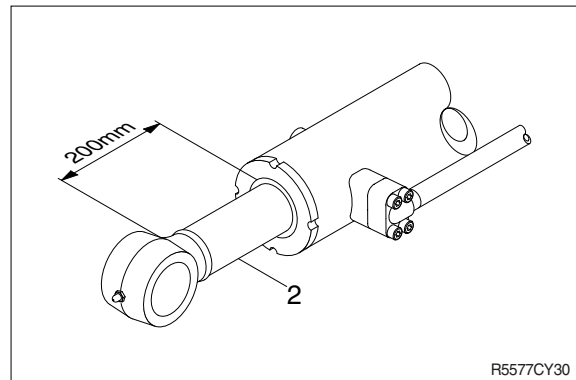

- ③ Loosen and remove socket bolts(22) of the gland(3) by hook spanner.
- ※ Cover the extracted rod assembly(2) with rag to prevent it from being accidentally damaged during operation.

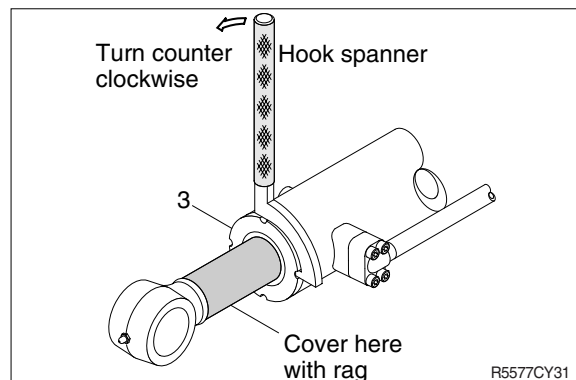

- ④ Draw out cylinder head and rod assembly together from tube assembly(1).
- ※ Since the rod assembly is heavy in this case, lift the tip of the rod assembly(2) with a crane or some means and draw it out. However, when rod assembly(2) has been drawn out to approximately two thirds of its length, lift it in its center to draw it completely.

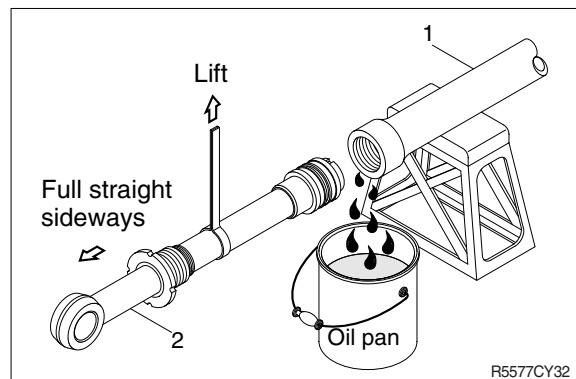

Note that the plated surface of rod assembly(2) is to be lifted. For this reason, do not use a wire sling and others that may damage it, but use a strong cloth belt or a rope.

- ⑤ Place the removed rod assembly on a wooden V-block that is set level.
- ※ Cover a V-block with soft rag.

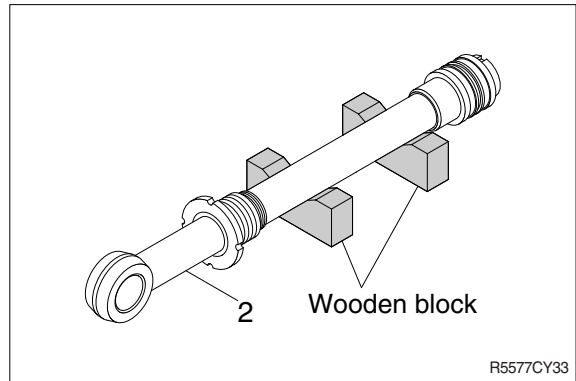

(2) Remove piston and gland

- ① Remove lock nut(22).
- ※ Since lock nut(22) is tightened to a high torque, use a hydraulic and power wrench that utilizes a hydraulic cylinder, to remove the lock nut(22).
- ② Remove piston assembly(16), back up ring(18), and O-ring(17).

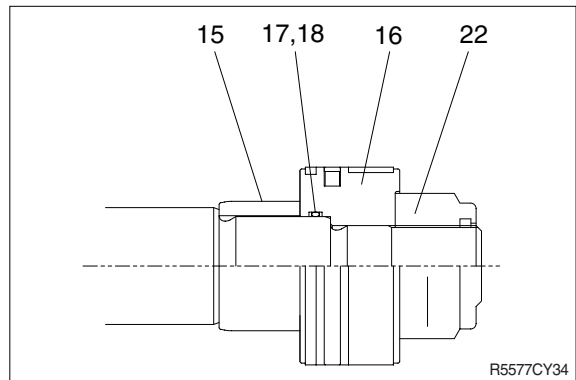

- ③ Remove the gland assembly from rod assembly(2).
 - ※ If it is too heavy to move, move it by striking the flanged part of gland with a plastic hammer.
 - ※ Pull it straight with gland assembly lifted with a crane.
- Exercise care so as not to damage the lip of Du bushing(4) and packing (5,6,7,8,9,10) by the threads of rod assembly(2).

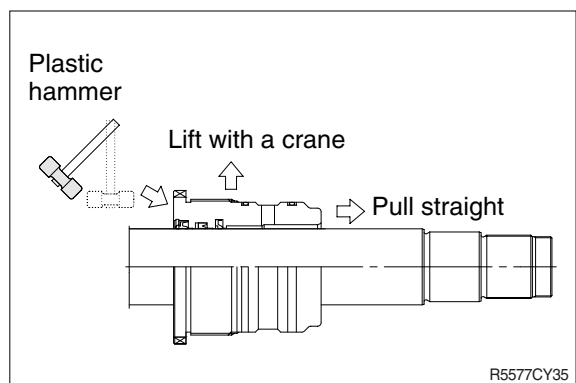

(3) Disassemble the piston assembly

- ① Remove wear ring(20).
 - ② Remove dust ring(21) and piston seal (19).
- ※ Exercise care in this operation not to damage the grooves.

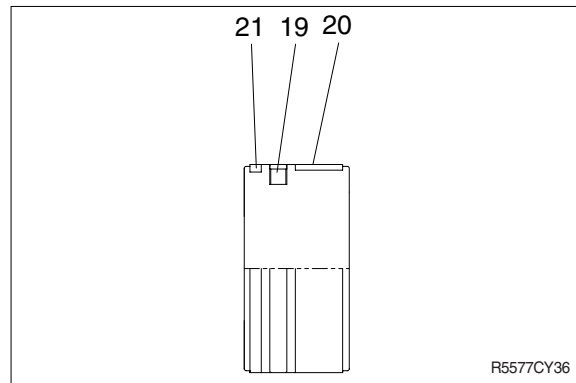

(4) Disassemble gland assembly

- ① Remove back up ring(12,14) and O-ring (11,13).
 - ② Remove snap ring(9), dust wiper(8).
 - ③ Remove back up ring(6), rod seal(5) and buffer ring(7).
- ※ Exercise care in this operation not to damage the grooves.
- ※ Do not remove seal and ring, if does not damaged.

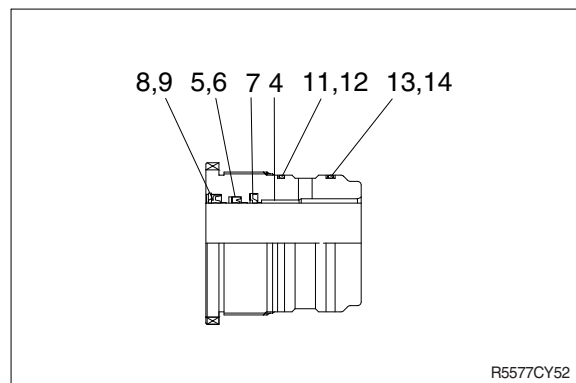

4) ASSEMBLY

(1) Assemble cylinder head assembly

- ※ Check for scratches or rough surfaces if found smooth with an oil stone.
- ① Coat the inner face of gland(3) with hydraulic oil.

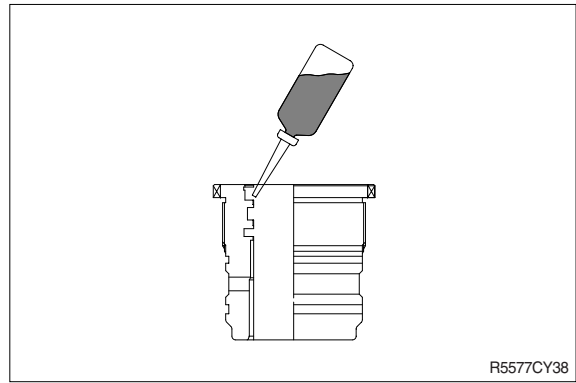

- ② Coat dust wiper(8) with grease and fit dust wiper(8) to the bottom of the hole of dust seal.

At this time, press a pad metal to the metal ring of dust seal.

- ③ Fit snap ring(9) to the stop face.

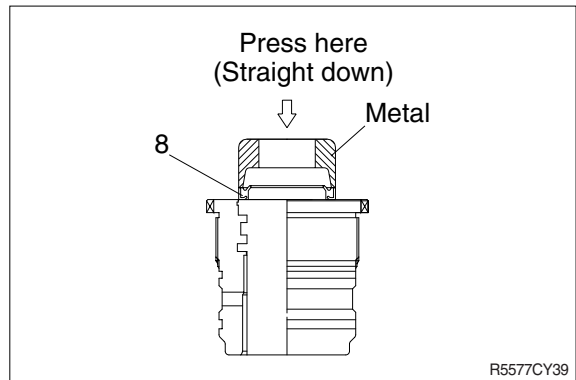

- ④ Fit back up ring(6), rod seal(5) and buffer ring(7) to corresponding grooves, in that order.

- ※ Coat each packing with hydraulic oil before fitting it.
- ※ Insert the backup ring until one side of it is inserted into groove.

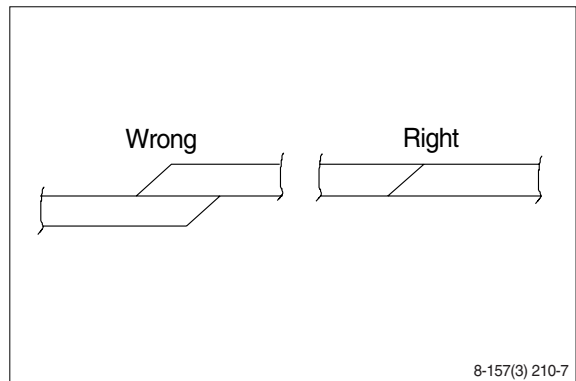

- ※ Rod seal(5) has its own fitting direction. Therefore, confirm it before fitting them.
- ※ Fitting rod seal(5) upside down may damage its lip. Therefore check the correct direction that is shown in fig.

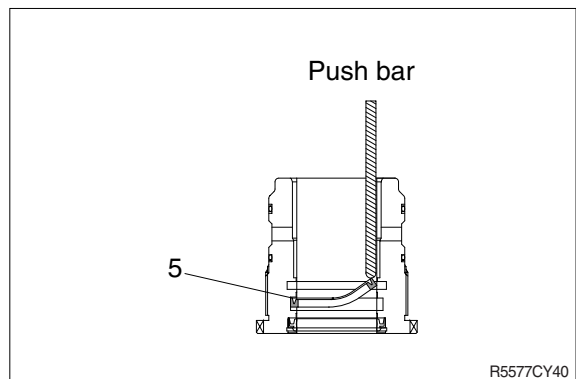

- ⑤ Fit back up ring(12,14) to gland(3).
- ※ Put the backup ring in the warm water of 30~50° C .
- ⑥ Fit O-ring(11,13) to gland(3).

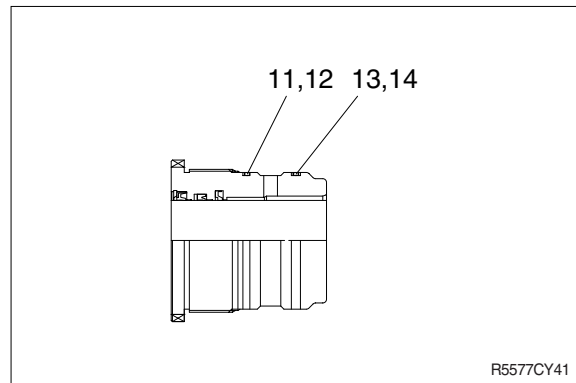

(2) Assemble piston assembly

- ※ Check for scratches or rough surfaces.
If found smooth with an oil stone.
- ① Coat the outer face of piston(14) with hydraulic oil.

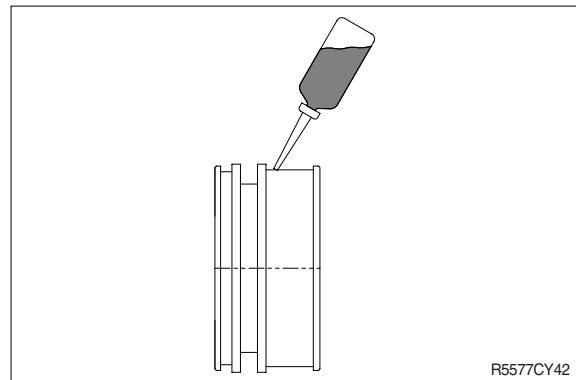

- ② Fit piston seal(19) to piston.
- ※ Put the piston seal in the warm water of 60~100° C for more than 5 minutes.
- ※ After assembling the piston seal, press its outer diameter to fit in.

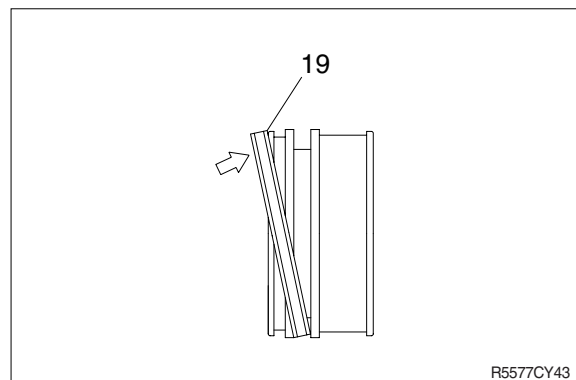

- ③ Fit wear ring(20) and dust ring(21) to piston(16).

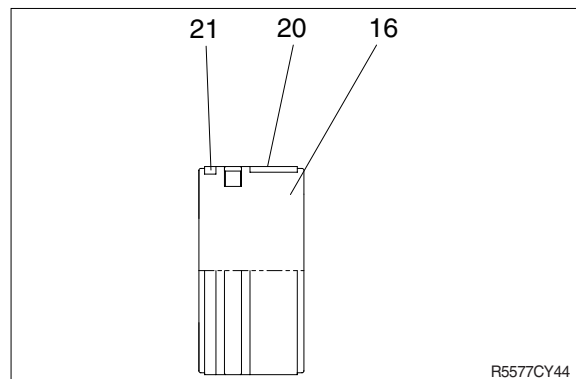

(3) Install piston and cylinder head

- ① Fix the rod assembly to the work bench.
- ② Apply hydraulic oil to the outer surface of rod assembly(2), the inner surface of piston and gland.
- ③ Insert gland assembly to rod assembly.

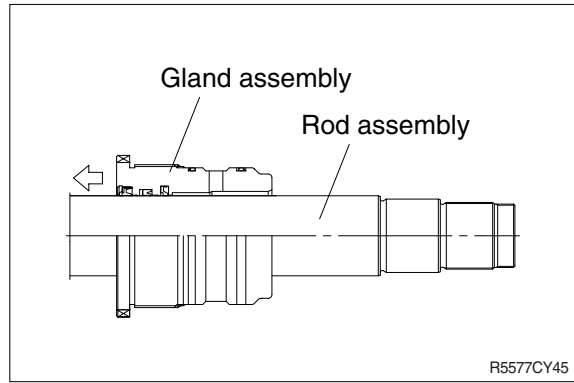

- ④ Insert cushion ring(15) to rod assembly.
- ※ Note that cushion ring(15) has a direction in which it should be fitted.

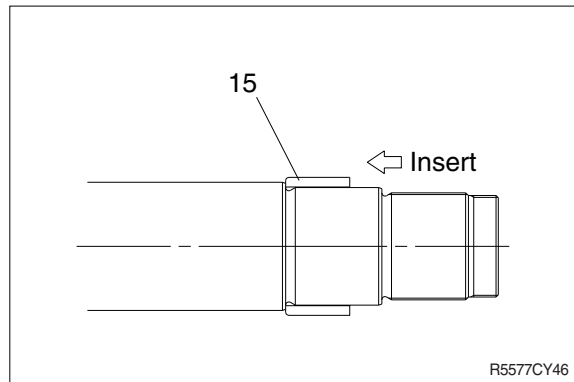

- ⑤ Fit piston assembly to rod assembly.

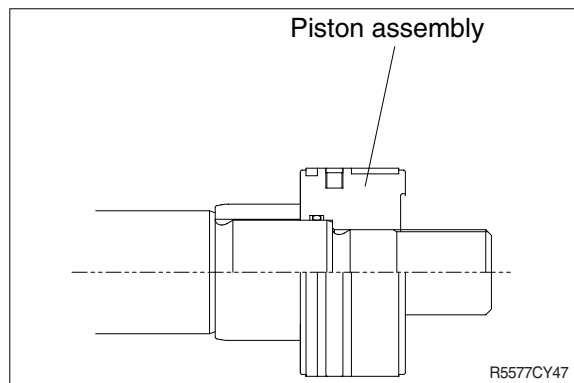

- ⑥ Fit lock nut to piston(22).
- Tightening torque :

Item		kgf · m	lbf · ft
Boom	22	292 ± 29	2110 ± 211
Arm	21	190 ± 19	1375 ± 138
Bucket	19	150 ± 15	1085 ± 109
Dozer	16	190 ± 19	1375 ± 138
Boom swing	16	190 ± 19	1375 ± 138

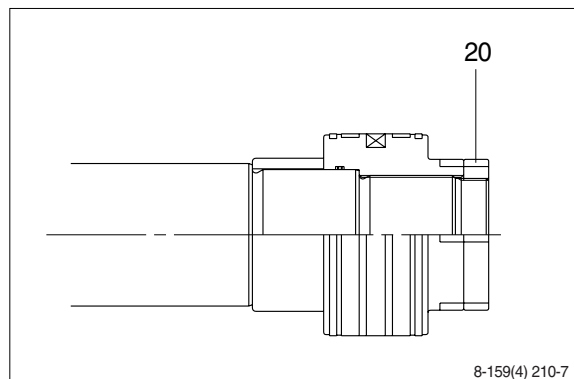

(3) Overall assemble

- ① Place a V-block on a rigid work bench.
Mount the tube assembly(1) on it and fix the assembly by passing a bar through the clevis pin hole to lock the assembly.
- ② Insert the rod assembly in to the tube assembly, while lifting and moving the rod assembly with a crane.
 - ※ Be careful not to damage piston seal by thread of tube assembly.
- ③ Match the bolt holes in the cylinder head flange to the tapped holes in the tube assembly and tighten socket bolts to a specified torque.
 - ※ Refer to the table of tightening torque.

