

GROUP 6 TRAVEL DEVICE

1. REMOVAL AND INSTALL

1) REMOVAL

- (1) Swing the work equipment 90° and lower it completely to the ground.
- (2) Operate the control levers and pedals several times to release the remaining pressure in the hydraulic piping.
- (3) Loosen the breather slowly to release the pressure inside the hydraulic tank.
- ▲ Escaping fluid under pressure can penetrate the skin causing serious injury.
 - ※ When pipes and hoses are disconnected, the oil inside the piping will flow out, so catch it in oil pan.
- (4) Remove the track shoe assembly.
For details, see **removal of track shoe assembly**.
- (5) Remove the cover.
- (6) Remove the hose.
 - ※ Fit blind plugs to the disconnected hoses.
- (7) Remove the bolts and the sprocket.
- (8) Sling travel device assembly(1).
- (9) Remove the mounting bolts(2), then remove the travel device assembly.
 - Weight : 80kg(180lb)

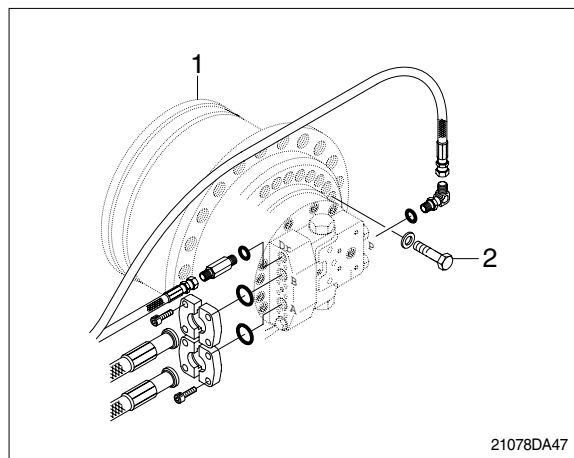

2) INSTALL

- (1) Carry out installation in the reverse order to removal.
- (2) Bleed the air from the travel motor.
 - ① Remove the air vent plug.
 - ② Pour in hydraulic oil until it overflows from the port.
 - ③ Tighten plug lightly.
 - ④ Start the engine, run at low idling, and check oil come out from plug.
 - ⑤ Tighten plug fully.
- (3) Confirm the hydraulic oil level and check the hydraulic oil leak or not.

2) STRUCTURE

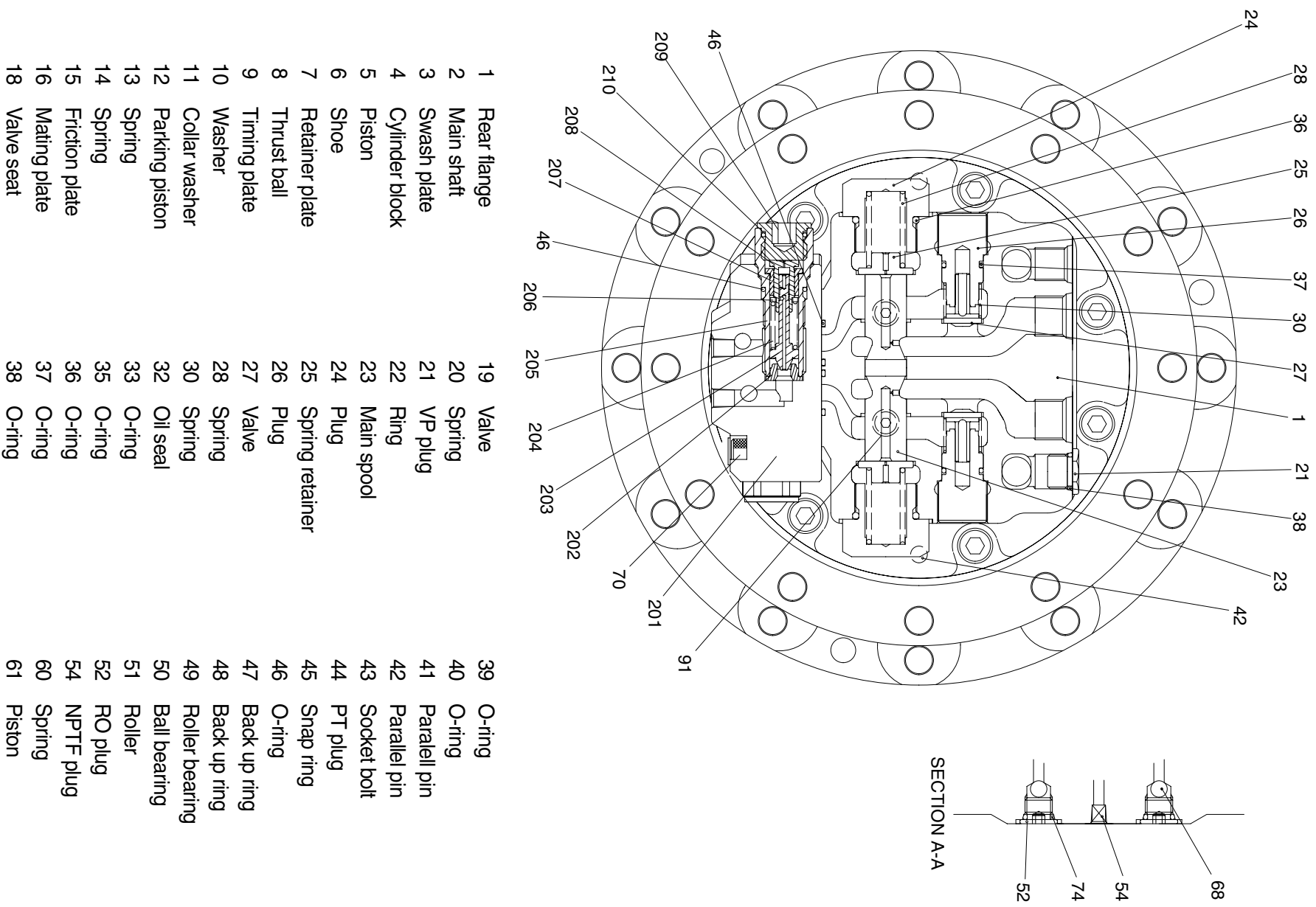

- | | | | | | |
|----|----------------|----|-----------------|----|----------------|
| 1 | Rear flange | 19 | Valve | 39 | O-ring |
| 2 | Main shaft | 20 | Spring | 40 | O-ring |
| 3 | Swash plate | 21 | VP plug | 41 | Paralell pin |
| 4 | Cylinder block | 22 | Ring | 42 | Paralell pin |
| 5 | Piston | 23 | Main spool | 43 | Socket bolt |
| 6 | Shoe | 24 | Plug | 44 | PT plug |
| 7 | Retainer plate | 25 | Spring retainer | 45 | Snap ring |
| 8 | Thrust ball | 26 | Plug | 46 | O-ring |
| 9 | Timing plate | 27 | Valve | 47 | Back up ring |
| 10 | Washer | 28 | Spring | 48 | Back up ring |
| 11 | Collar washer | 30 | Spring | 49 | Roller bearing |
| 12 | Parking piston | 32 | Oil seal | 50 | Ball bearing |
| 13 | Spring | 33 | O-ring | 51 | Roller |
| 14 | Spring | 35 | O-ring | 52 | RO plug |
| 15 | Friction plate | 36 | O-ring | 54 | NPTF plug |
| 16 | Mating plate | 37 | O-ring | 60 | Spring |
| 18 | Valve seat | 38 | O-ring | 61 | Piston |

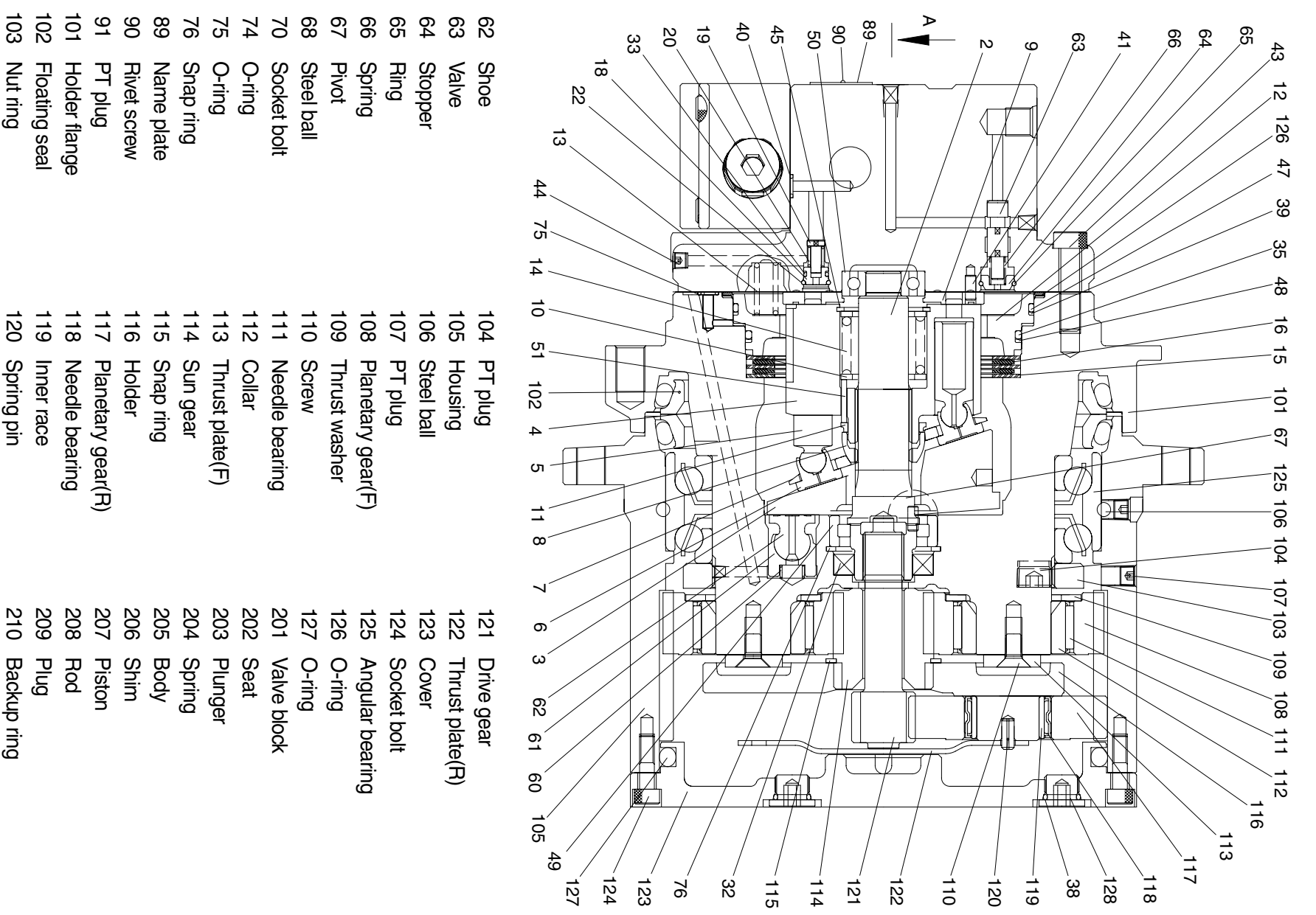

- | | | | | | | | |
|----|----------------|-----|---------------|-----|-------------------|-----|-----------------|
| 39 | O-ring | 62 | Shoe | 104 | PT plug | 121 | Drive gear |
| 40 | O-ring | 63 | Valve | 105 | Housing | 122 | Thrust plate(R) |
| 41 | Paralell pin | 64 | Stopper | 106 | Steel ball | 123 | Cover |
| 42 | Paralell pin | 65 | Ring | 107 | PT plug | 124 | Socket bolt |
| 43 | Socket bolt | 66 | Spring | 108 | Planetary gear(F) | 125 | Angular bearing |
| 44 | PT plug | 67 | Pivot | 109 | Thrust washer | 126 | O-ring |
| 45 | Snap ring | 68 | Steel ball | 110 | Screw | 127 | O-ring |
| 46 | O-ring | 70 | Socket bolt | 111 | Needle bearing | 201 | Valve block |
| 47 | Back up ring | 74 | O-ring | 112 | Collar | 202 | Seat |
| 48 | Back up ring | 75 | O-ring | 113 | Thrust plate(F) | 203 | Plunger |
| 49 | Roller bearing | 76 | Snap ring | 114 | Sun gear | 204 | Spring |
| 50 | Ball bearing | 76 | Snap ring | 115 | Snap ring | 205 | Body |
| 51 | Roller | 89 | Name plate | 116 | Holder | 206 | Shim |
| 52 | RO plug | 90 | Rivet screw | 117 | Planetary gear(R) | 207 | Piston |
| 60 | Spring | 91 | PT plug | 118 | Needle bearing | 208 | Rod |
| 61 | Piston | 101 | Holder flange | 119 | Inner race | 209 | Plug |
| | | 102 | Floating seal | 120 | Spring pin | 210 | Backup ring |
| | | 103 | Nut ring | | | | |

R5572TM10

2. DISASSEMBLY

1) GENERAL PRECAUTIONS

- (1) Before disassembling the TM motors, check the items to be inspected and, for remedy against trouble, closely examine the nature of the trouble, so that the motor can be disassembled effectively.
- (2) To disassemble the motor, use the disassembling procedures described in section 2-2, and select a clean place.
- (3) Place a rubber or vinyl sheet or other such protective materials on your working bench to protect the surface of the motor to be serviced.
- (4) During disassembly, give a match mark to the mating surfaces of each part.
- (5) Arrange removed parts in order so that they will not become damaged or missing during disassembly.
- (6) Once seals have been disassembled, they should be replaced even if damage is not observed. Have replacement seals ready on hand before starting your disassembling job.

2) SPECIAL TOOLS

(1) Inversion working bench.

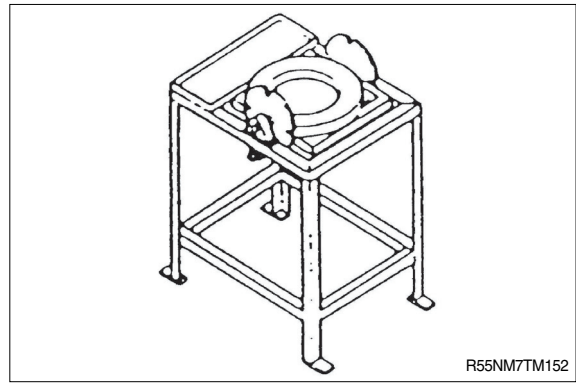

(2) Retainer (I).

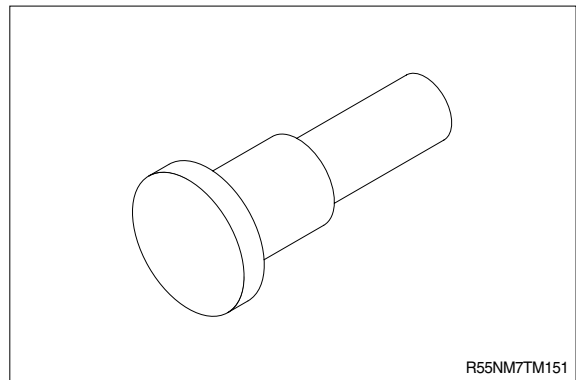

(3) Retainer (II).

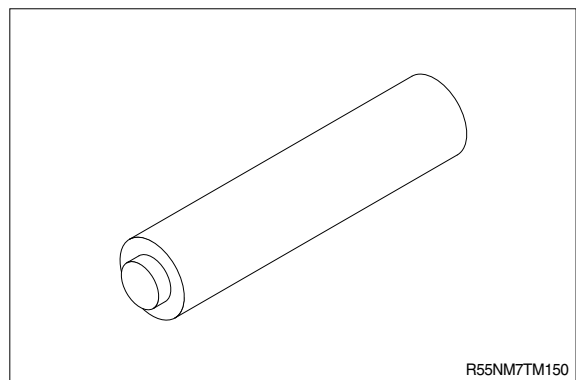

(4) Aluminum rod.

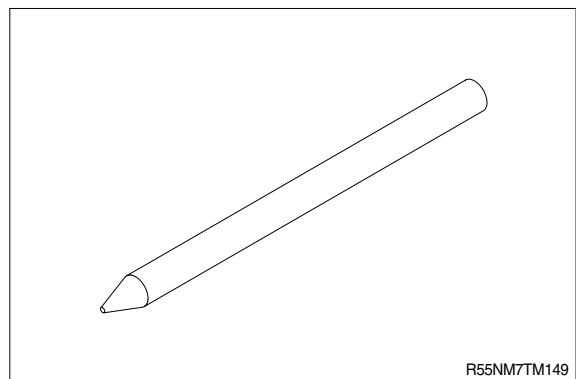

(5) Retainer (I).

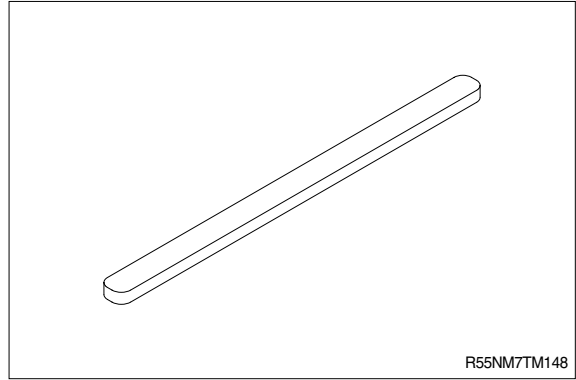

(6) Retainer (II).

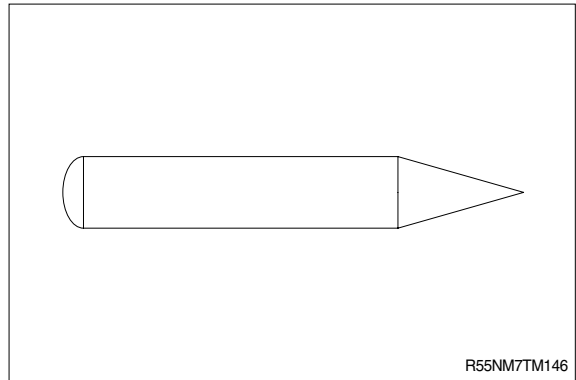

(7) Aluminum rod.

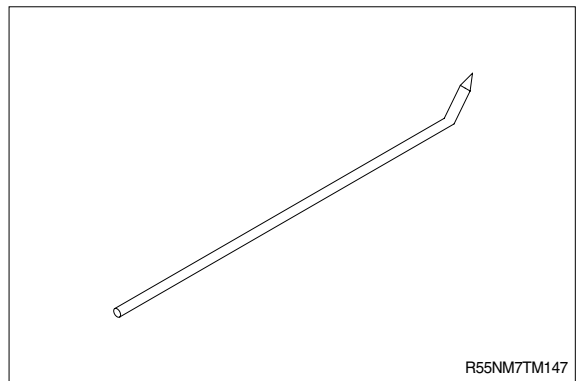

3) REAR FLANGE

- (1) Loosen the four hex.(hexagon) socket head bolts(70) and remove the relief valve block(201) from the rear flange(1).
- (2) Remove the two O-rings(40), (46) from the rear flange(1).

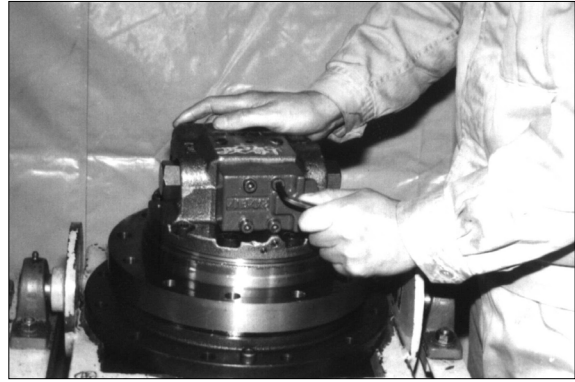

R55NM7TM120

- (3) Remove the hex. socket head bolts(43).
(Hexagon socket head bolt : 8EA)



R55NM7TM119

- (4) Remove the rear flange(1) from the holder flange(101).

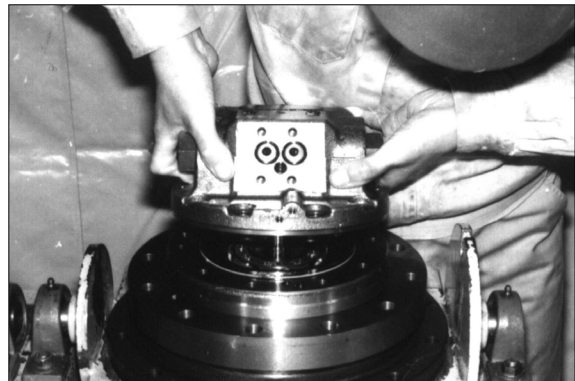

R55NM7TM121

- (5) Remove the timing plate(9), the two pins(41), the eight springs(13), the ball bearing(50), and O-ring(126) from the rear flange(1) and holder flange(101).

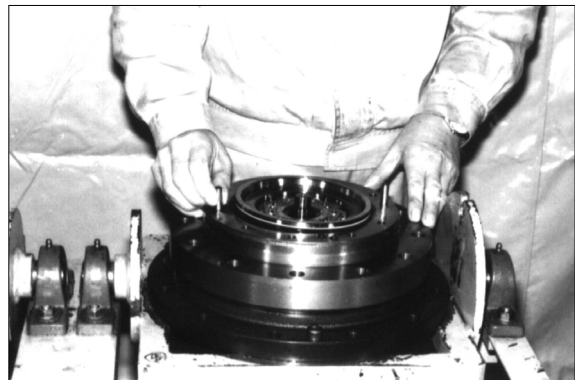

R55NM7TM122

4) BRAKE VALVE

(1) To remove the spool

- ① Remove the two plugs(24) from the rear flange(1).
Remove the O-ring(36) from the plug(24).

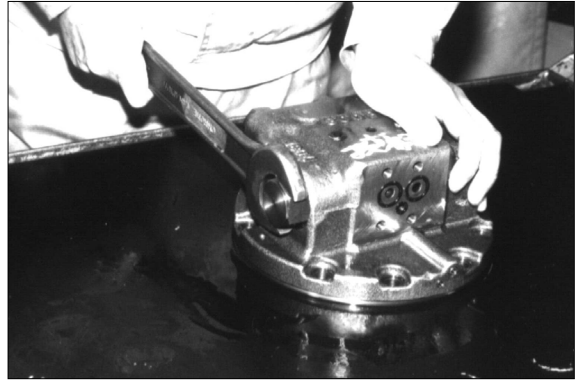

R55NM7TM110

- ② Remove the two springs(28), the two spring retainers(25), and the spool(23) from the rear flange(1).
※ Be careful not to damage the outer surface of the rear flange(1).



R55NM7TM108

(2) To remove the check valves

- ① Remove the two plugs(26) from the rear flange(1).

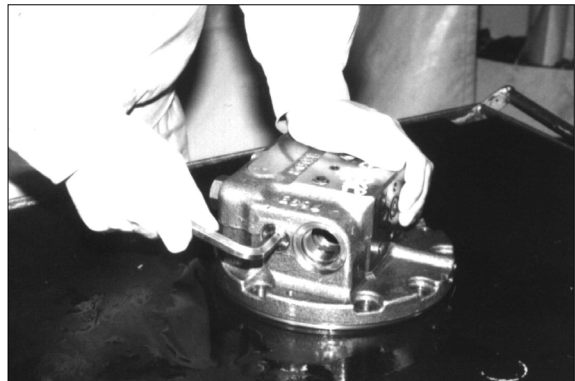

R55NM7TM101

- ② Remove the two springs(30) and the two valves(27) from the rear flange(1).
※ Be careful not to damage the seat section of valves(27) or rear flange(1).
- ③ Remove the O-ring(34) from the plug(26).

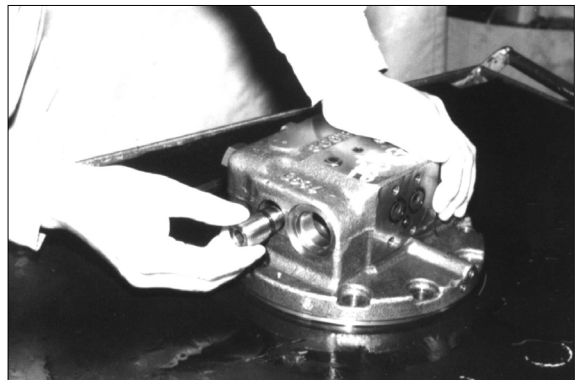

R55NM7TM136

(3) To remove the T-valve(19) from the rear flange(1)

- ① Press and hold down the valve seat(18) using a steel bar, and in that state, as shown in the diagram at right, press the notch in the ring(22) using a sharp pointed steel bar. This deforms the ring(22), disengaging it from the ring groove in the rear flange(1). The ring(22) can now be removed from the rear flange(1).

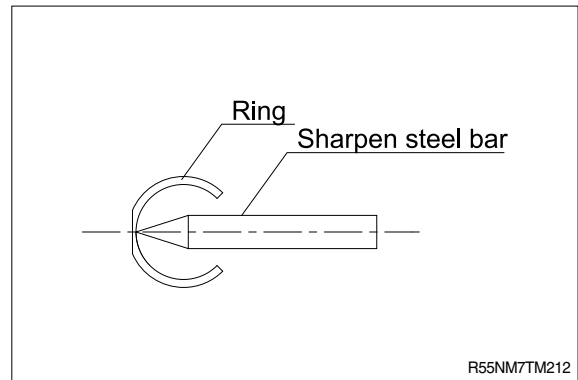
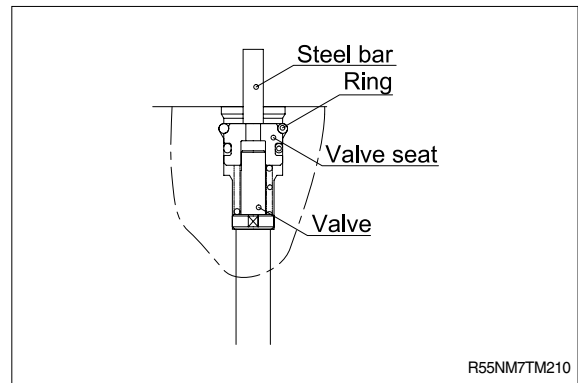

- ② After filling up the hole section of the valve seat(18), inject compressed air from the parking brake access hole and remove the valve seat(18).
- ③ Holding the rear flange(1) by hand and lightly shaking it with its hole section facing downward allows the T-valve(19) and the spring(20) to be removed or using tweezers or any other such tool, remove the T-valve(19) and the spring(20) from the rear flange(1)
- ④ Remove the O-ring(33) from the valve seat(18).

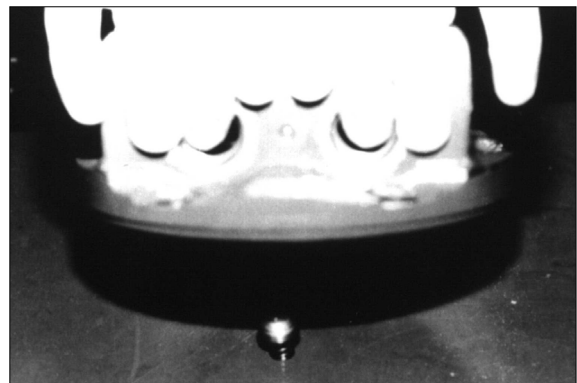

(4) To remove the valve(63) from the rear flange(1)

- ① Press and hold down the stopper(64) using a steel bar, and in that state, as shown in the diagram at right, press the notch in the ring(65) using a sharp pointed steel bar. This deforms the ring(65), disengaging it from the ring groove in the rear flange(1). The ring(65) can now be removed from the rear flange(1)

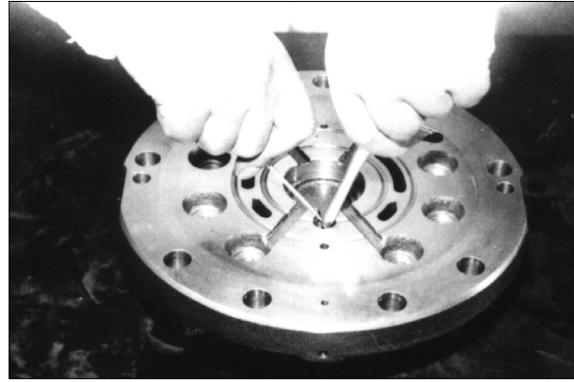

R55NM7TM104

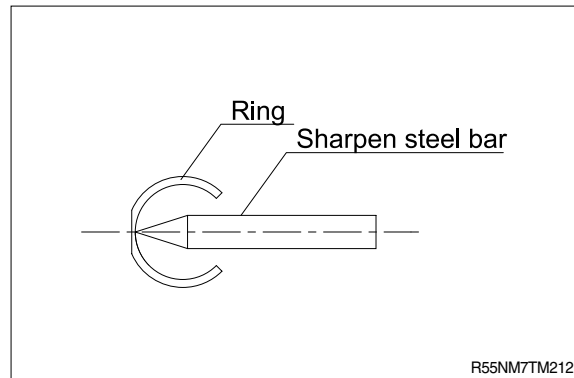

R55NM7TM212

- ② Make the hole section of the removed ring(65) face downward, and lift the rear flange(1). This allows the stopper(64), the spring(166) and the valve(63) from the rear flange(1).

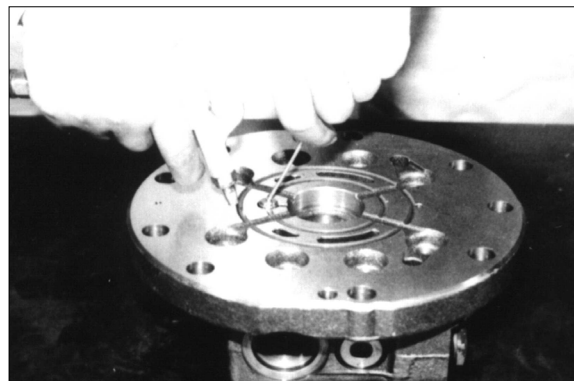

R55NM7TM106

5) HYDRAULIC MOTOR

(1) To remove the parking brake parts

- ① Remove the piston(12) by injecting compressed air from the parking brake access hole in the holder flange(101).
※ Take care that abrupt injection of compressed air may cause the piston(12) to pop out.

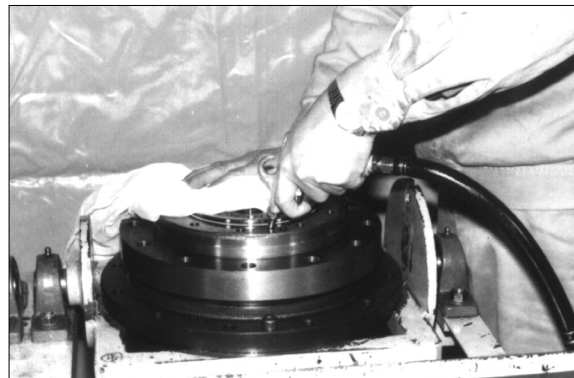

R55NM7TM127

- ② Remove the O-rings(35), (39) from the piston(12).



R55NM7TM129

(2) To remove the internal parts of the motor

- ① Lay the TM motor body on the side.
- ② Drain out the oil from the TM motor.
- ③ Hold the cylinder block(4) with both hands, and remove it from the holder flange(101)
- ※ Before removal, hold the cylinder block(4) with both hands and turn it two to three times in a clockwise and a counterclockwise direction alternately to detach the shoe(6) from the swash plate(3).
- ※ Be careful that if an attempt is made to remove the cylinder block(4) without detaching the shoe(6) from the swash plate(3), then the piston, shoe and other parts that are connected to the cylinder block may come loose and fall into the spindle.

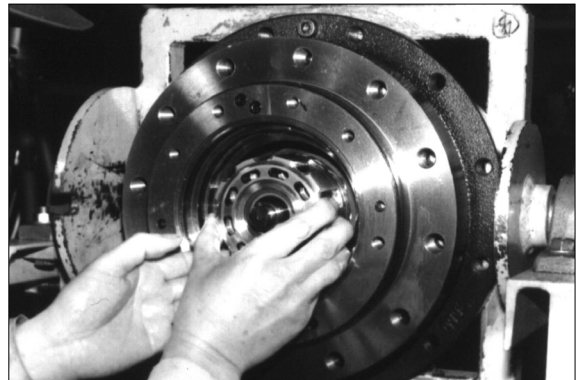

R55NM7TM131

- ④ Remove the four mating plates(16) and three friction plates(15) that are mounted on the outer surface of the removed cylinder block(4).
- ⑤ Remove the piston assy piston(5), shoe(6), retainer plate(7), thrust ball(8), and three rollers(51) from the removed cylinder block(4).

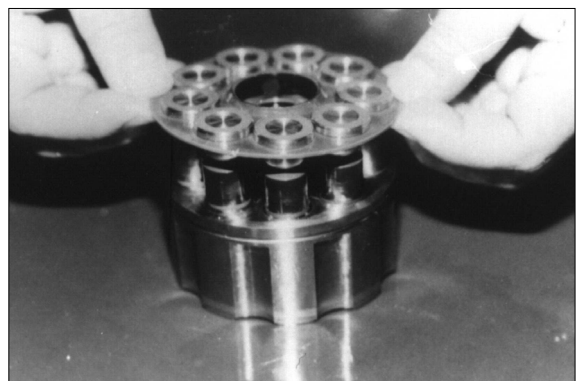

R55NM7TM132

- ⑥ Remove the swash plate(3) from the holder flange(101).
- ⑦ Remove the two steel balls(67) from the holder flange(101).
- ⑧ Remove the speed selector piston assy piston(61) and shoe(62) from the holder flange(101) by feeding compressed air(3 to 5kgf/cm²) from the access hole in holder flange(101).



(3) To disassembly the inside of the cylinder block(4)

- ① Place the cylinder block(4) on a press working bench, and then while pressing and holding down a retainer(I) against the washer(10), remove the snap ring(45) using snap ring pliers.
- ※ Press load : 120 kgf or more.
- ※ Protect the sliding surface of the cylinder block with a vinyl sheet.



R55NM7TM133

- ② Remove the snap ring(45) the washer(10), the spring(14), and the washer(10), in that order, from the cylinder block(4).



R55NM7TM137

(4) To remove the shaft(2) and the roller bearing(49)

- ① Remove the shaft(2) from the holder flange(101).
- At this time, the roller bearing(49) can also be removed in conjunction with the shaft(2).
- The oil seal(32), however, cannot be removed.



R55NM7TM118

6) REDUCTION GEAR

- (1) Remove the plugs(10) from the cover(123).
- (2) Loosen the socket bolts(124) and remove the cover(123) from the housing(105).

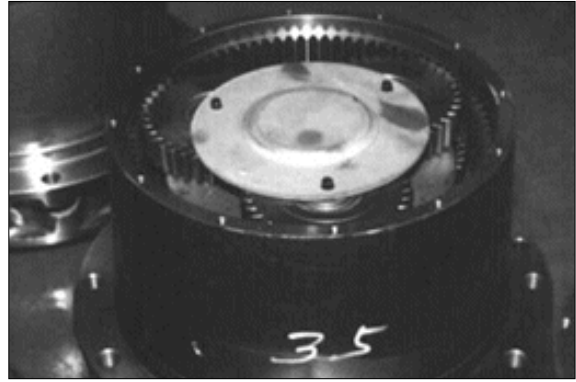

- (3) Remove the thrust plate(R)(122) and the drive gear(121).



- (4) Remove the planetary gear(R)(117), the needle bearing(118), the inner race(119) and the holder(116).



- (5) Remove the sun gear(114), the screw(110), the thrust plate(F)(113) and the needle bearing(111).

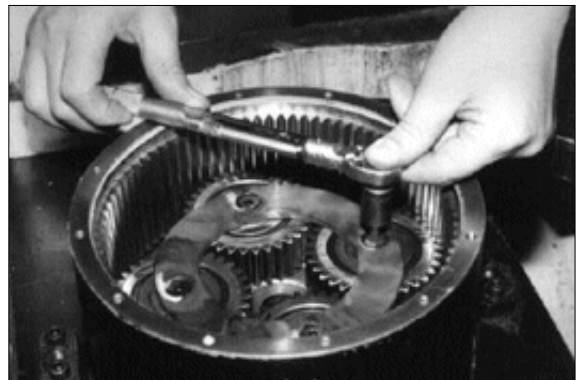

(6) Remove the collar(112) and the thrust washer(109).

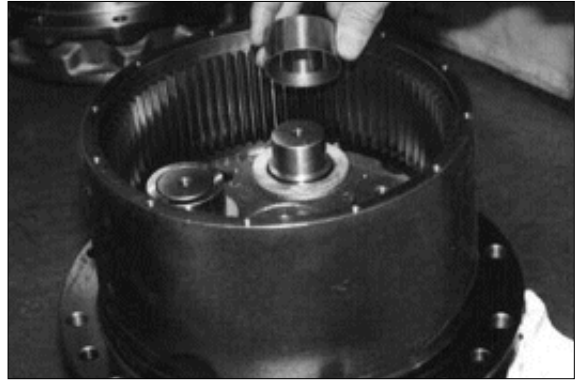

R55NM7TM126

(7) Remove the plugs(124).

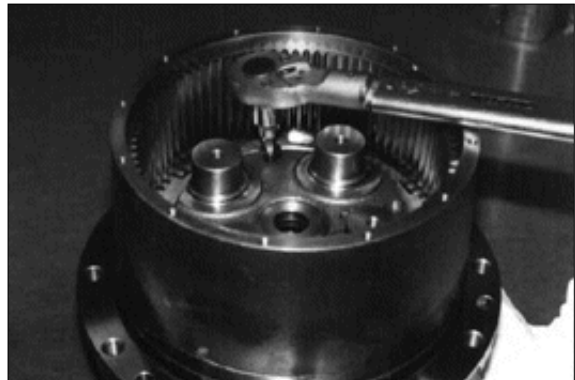

R55NM7TM128

(8) Remove the nut ring(103).



R55NM7TM130

(9) Remove the holder flange(101) from the housing(105).



R55NM7TM116

(10) Remove the plug(104) and steel ball(106)
(104ea).

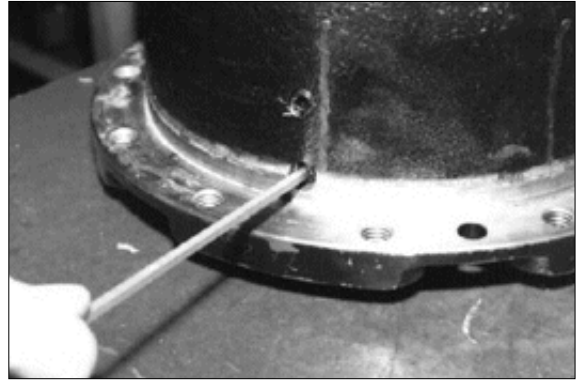

R55NM7TM113

(11) Remove the floating seal(102) and
angular bearing(125).

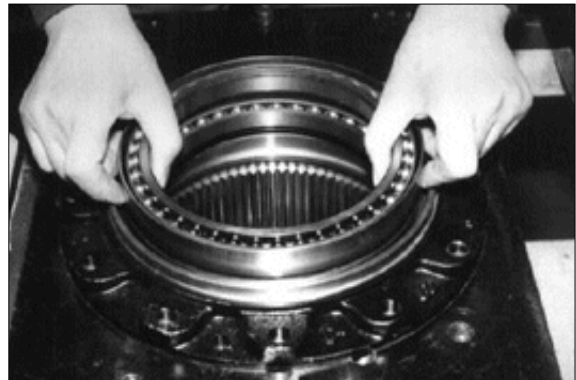

R55NM7TM109

(12) Remove the floating seal(102) from the
holder flange(1).



R55NM7TM134

(13) Remove the snap ring(76).

(14) Remove the oil seal(32).



R55NM7TM135

3. REASSEMBLY

1) GENERAL PRECAUTIONS

- (1) Reassemble in a work area that is clean and free from dust and grit.
- (2) Handle parts with bare hands to keep them free of lumpy contaminants.
- (3) Repair or replace the damaged parts.
Each part must be free of burrs at its corners.
- (4) Do not reuse O-rings, oil seal and floating seal that were removed in disassembly.
Provide the new parts.
- (5) Wash all parts thoroughly in a suitable solvent.
Dry thoroughly with compressed air
Do not use the cloths.
- (6) When reassembling oil motor components of TM motor, be sure to coat the sliding parts of the motor and valve with fresh hydraulic oil.(NAS class 9 or above).
- (7) Use a torque wrench to tighten bolts and plugs, to the torque specified as follows.

2) TIGHTENING TORQUE TABLE

Item No	Parts name	Size	Tightening torque		
			kgf · cm	lbf · in	
21	Plug	PF 3/8	600	520.8	
24	Plug	M30 P1.5	3600	3125	
26	Plug	M24 P1.5	1300	1128	
43	Hex. socket bolt	M10 P1.5	590	512	
44, 107	Hex. socket plug	PT 1/8	125	108.5	
52	Hex. socket plug	PF 1/4	300	260	
54	Hex. socket plug	NPTF 1/16	100	86.8	
63	Hex. socket plug	PF 1/2	1000	868	
69	Hex. socket bolt	M3	100	86.8	
70	Hex. socket bolt	M8	300	260	
71	Hex. socket bolt	M4	125	108.5	
91	Hex. socket plug	PT 1/4	300	260	
103	Nut ring	DOOSAN	M165 × P2	1800	1562
		JEIL		4300	3732
104	Hex. socket plug	PT 3/8	350	304	
110	Screw	M6	83	72	
124	Hex. socket bolt	M8	300	260	

3) REDUCTION GEAR

- (1) Mount end of the floating seal(102) in the holder flange(101).

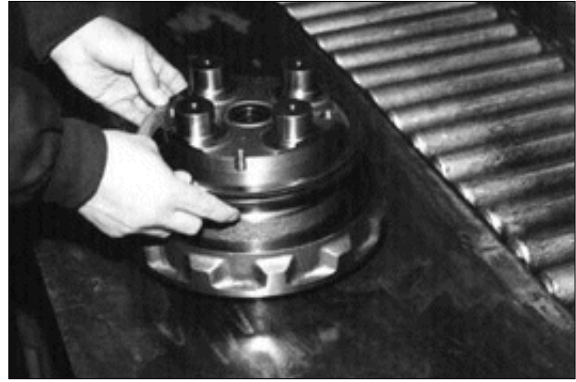

R55NM7TM107

- (2) Press angular bearing(125) into the housing(105).

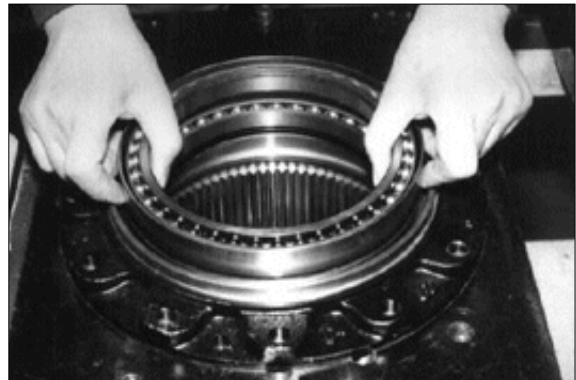

R55NM7TM109

- (3) Insert the steel balls(106)(104ea) into the housing(105).



R55NM7TM111

- (4) Place seal taper around plug(104) and tighten it up.

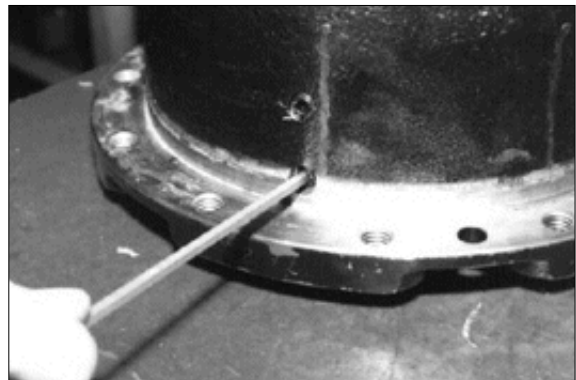

R55NM7TM113

(5) Mount another end of floating seal(102) into the housing(105).

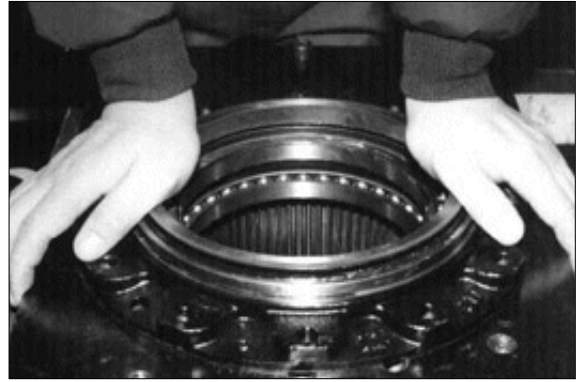

R55NM7TM115

(6) Fit the holder flange(101) into the housing(105).

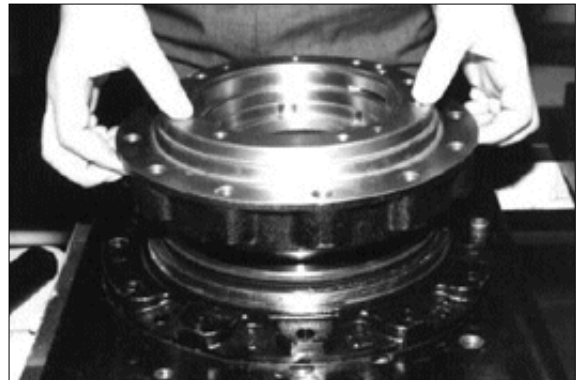

R55NM7TM116

(7) Tighten the nut ring(103) and the plugs(104) to the required torque using a torque wrench.

※ Tightening torque :

DOOSAN	1800 kgf · cm (1562 lbf · ft)
JEIL	4300 kgf · cm (3732 lbf · ft)



R55NM7TM130

(8) Mount the thrust washer(109) and the collar(112).

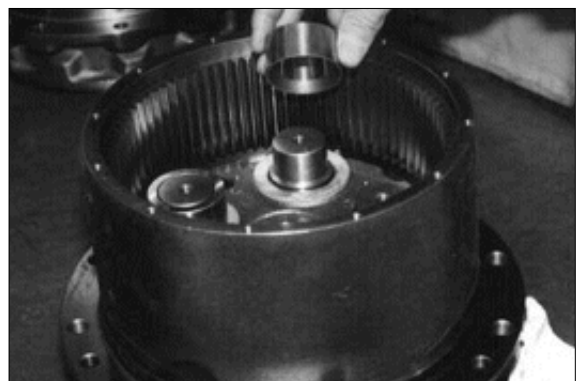

R55NM7TM126

- (9) Fit the needle bearing(111) and place the thrust plate(F)(113). Tighten the screw (110) to required torque using torque wrench.

※ Tightening torque : 83kgf · cm(72lbf · in)

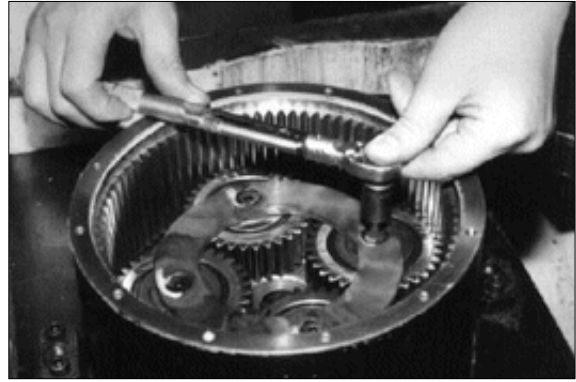

R55NM7TM125

- (10) Fit holder ass'y sun gear(114), needle bearing(118) and planetary gear(R)(117).



R55NM7TM138

- (11) Attach the drive gear(121) and place thrust plate(R)(122).

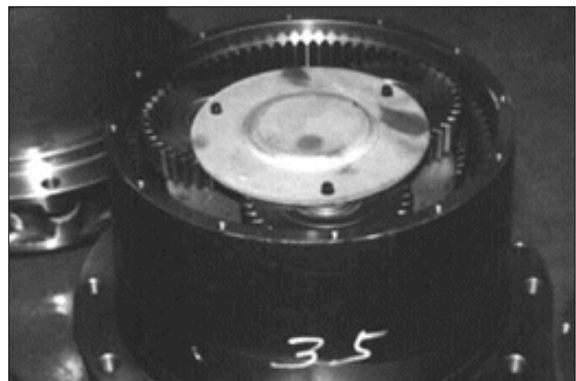

R55NM7TM103

- (12) Fit the cover(123) to the housing(105).
(13) Tighten socket bolts(124) to the required torque using a torque wrench.
※ Tightening torque : 125kgf · m(904lbf · ft)

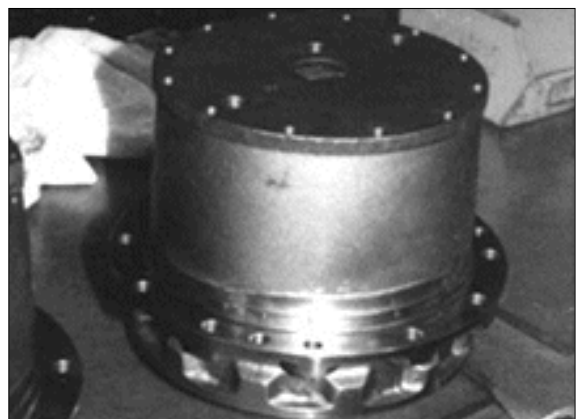

R55NM7TM140

4) BRAKE VALVE

(1) To remount the check valve

- ① Fit the O-ring(37) on the plug(26).
 - ② Insert the spring(30) and the valve(27) into the plug(26), and then grease the spring(30) and the valve(30) and hand-lock the former.
- ※ Tightening torque : $26 \pm 4 \text{kgf} \cdot \text{m}$
($188 \pm 28.9 \text{lbf} \cdot \text{ft}$)
- ③ Insert the plug(26) in conjunction with the spring(30) and the valve(30) into the rear flange(1), and tighten the plug to the required torque.
- ※ Tightening torque : $26 \pm 4 \text{kgf} \cdot \text{m}$
($188 \pm 28.9 \text{lbf} \cdot \text{ft}$)

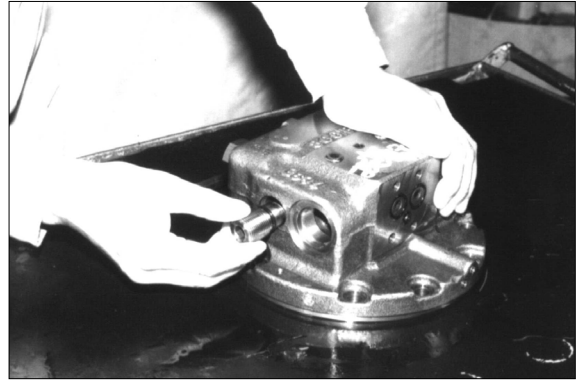

R55NM7TM136

(2) To remount the spool

- ① Insert the spool(23) into the rear flange(1).



R55NM7TM108

- ② Attach the O-ring(36) to the plug(24).
 - ③ Install spring retainer(25) and the spring(28) into both plugs(24), and tighten the plugs(24) into the rear flange(1) at the required torque.
- ※ Required torque : $45 \pm 9 \text{kgf} \cdot \text{m}$
($32.5 \pm 65 \text{lbf} \cdot \text{ft}$)



R55NM7TM110

(3) To remount the parking brake valve

- ① Mount the O-ring(33) on the valve seat(18).
- ② Insert the valve(19), the spring(20), and the valve seat(18), in that order, into the rear flange(1).



- ③ Slightly bend a new ring and place it in the new ring into the ring groove of the rear flange.

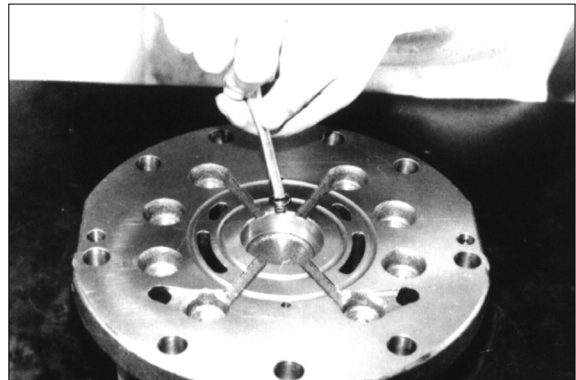

R55NM7TM117

(4) To remount the valve(63)

- ① Holding the rear flange(1) with its surface contacting the holder flange(101) upward, place the rear flange on a working bench.
- ② Insert the valve(63) into the rear flange(1).
- ③ Fit the spring(66) into the valve(63), and mount the stopper(64) on it.



R55NM7TM143

- ④ Slightly bench a new ring(65) and insert it into the rear flange(1) from the top of the stopper(64).
Then, fit the new ring into the ring groove of the rear flange.

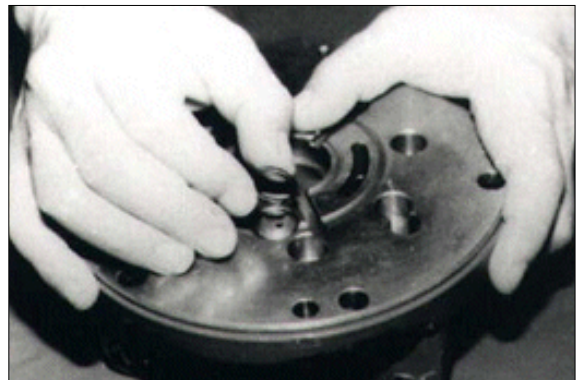

R55NM7TM142

5) HYDRAULIC MOTOR

(1) To remount the shaft(2)

- ① Fit the oil seal(32), the snap ring(45) and roller bearing(49) in that order, into the holder flange(101).
- ② Insert the shaft(2) into the roller bearing(49).

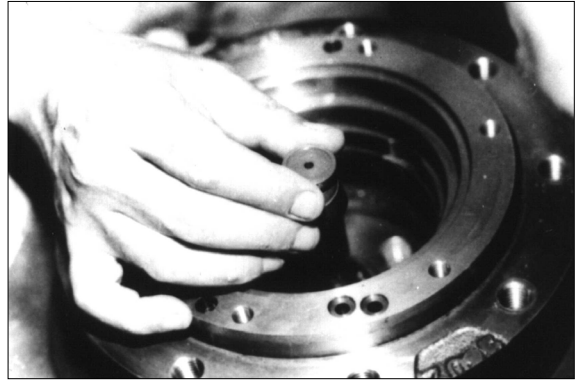

R55NM7TM118

(2) To reassemble the piston ass'y(61), (62)

- ① Mount the piston ass'y(61), (62) in the piston hole of the holder flange(101).

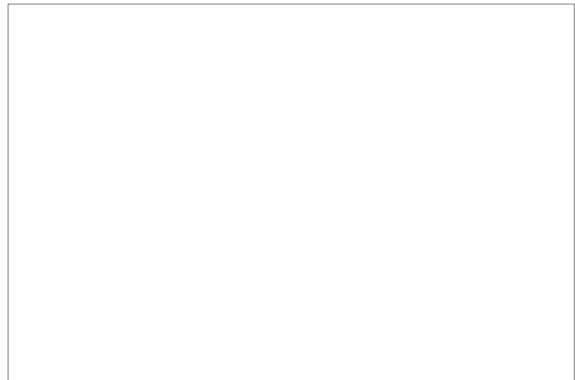

(3) To reassemble cylinder block section

- ① Insert washer(10), spring(14), washer(10) and the snap ring(45) in that order, into the shaft bore of cylinder block(4).



R55NM7TM137

- ② Set cylinder block in the press in order to compress the spring(14). Place retainer(I) on the washer(10) and push down this tool with the press until the snap ring groove becomes cleared. Fit snap ring(45) into the groove.



R55NM7TM133

(4) Piston motor sub-assembly

- ① Fit 3-rollers(51) into the pin holes of cylinder block(4), and then, put thrust ball(8) on it.
- ② Insert piston assembly into retainer plate(7).
- ③ Mount the piston assembly into the cylinder block(4). After mounting, immerse the entire them in a working fluid.

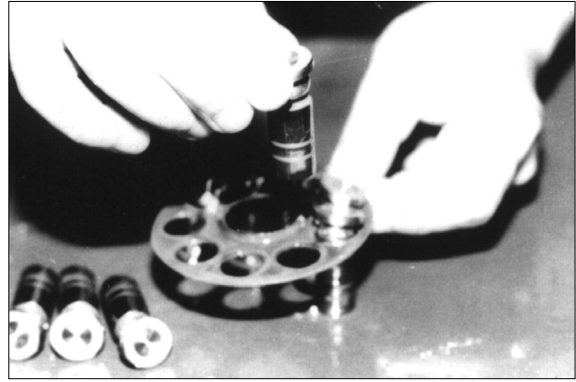

R55NM7TM144

- ④ Fit the spring(60) into the piston(62).
- ⑤ Insert the piston(62) and steel balls(68) into the hole of the holder flange(101).



R55NM7TM139

- ⑥ Mount the swash plate(3) on the steel balls(68).

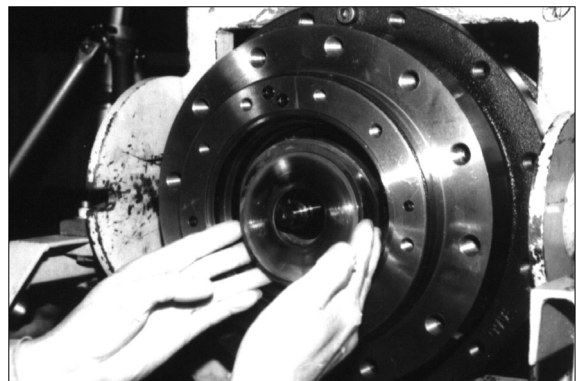

R55NM7TM145

- ⑦ Fit the cylinder block & piston into the shaft(5).

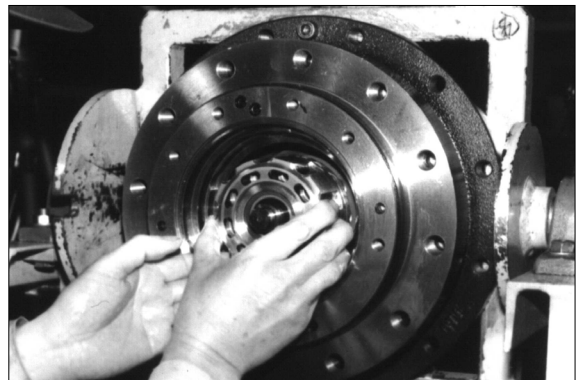

R55NM7TM131

(5) To reassemble the parking brake section

- ① Fit the mating plate(16) first and then the friction plate(15), one by one, into the grooves of the outer surface of the cylinder block(4).

※ This order of fitting must be strictly observed.

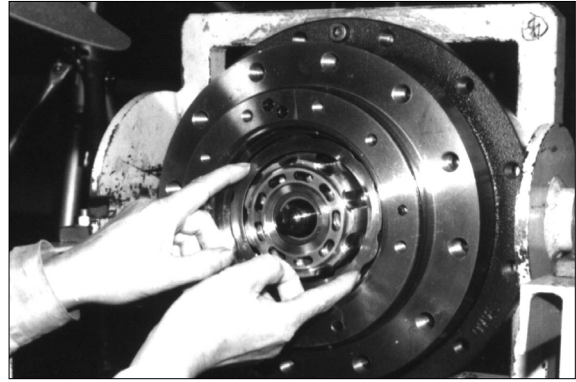

R55NM7TM141

- ② Fit the O-rings(39), (35) in the O-ring grooves of the piston(12).
- ③ Mount the piston(12) in the holder flange(101).



R55NM7TM129

- ④ Fit the O-ring(75) and the O-ring(126) in the O-ring groove of the holder flange(101).
- ⑤ Fill the holder flange(101) with a working fluid quantity required : 1.2 liters

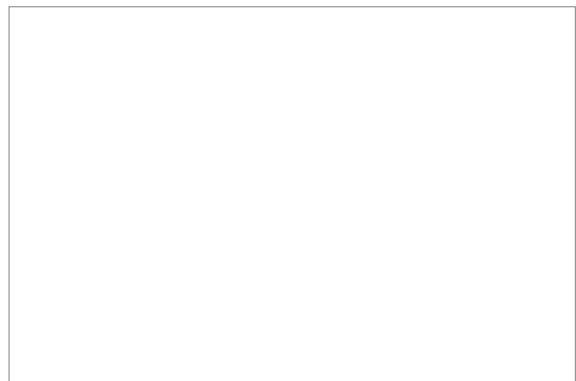

(6) To mount the rear flange(1) back in the holder flange(101)

- ① Mount the ball bearing(50) in the rear flange(1).
- ② Fit the two dowel pins(41) into the pin holes of the rear flange(1).
- ③ Using the dowel pins(41) as a guide, mount the timing plate(9) in the rear flange(1).

At this time, apply grease to the contact surface of the timing plate(9) and the rear flange(1).

- ④ Arrange the eight springs(113) correctly in the spring mounting hole of the rear flange(1).
- ⑤ Fit the two dowel pins(42) into the holder flange(101).

⑥ Mount the rear flange(1) on the holder flange(101).

At this time, the two dowel pins that have been fitted into the holder flange(101) must be aligned with the pin holes.

⑦ Tighten the eight hex. socket head bolts into the holder flange(101) at the required torque.

- Tightening torque : $25.7 \pm 4 \text{kgf} \cdot \text{m}$
($185.9 \pm 29 \text{lbf} \cdot \text{ft}$)

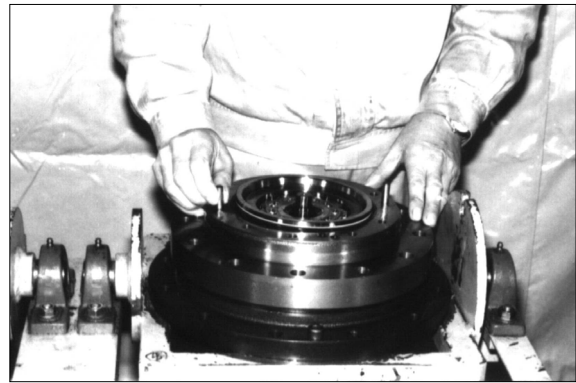

R55NM7TM122

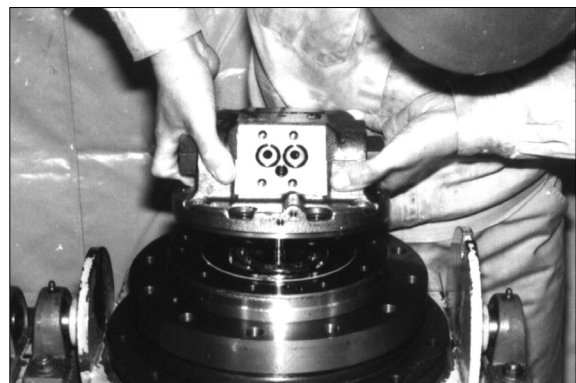

R55NM7TM121



R55NM7TM119

4. TESTING

The motor case must be filled up with a working fluid before starting performance verification tests. After completion of TM motor servicing, the performance verification tests listed below must be performed.

1) WHEN A TESTING APPARATUS IS AVAILABLE :

※ If internal parts have been replaced, carry out running in operation, followed by performance tests.

(1) Conditions for running-in operation

- ① 10 rpm, no-load pressure, one minute, clockwise/counterclockwise rotation.
- ② 20 rpm, no-load pressure, one minute, clockwise/counterclockwise rotation.
- ③ 20 rpm, 100kgf/cm², two minutes, clockwise/counterclockwise rotation.

(2) Condition for performance tests

- ① Working fluid : ISO VG #46 wear-resistant type.
- ② Lubricating oil : Gear oil.
- ③ Temperatures : Ambient temperature ---- Room temperature.
 Working fluid temperature ---- 50±5 °C
 Casing temperature of ---- 40 to 80 °C
 reducer section
 Drainage pressure : 0.8kgf/cm² or less

(3) Efficiency tests (for the first speed)

Volume efficiency	Machine efficiency	External drainage amount (Referential data)	Remarks
90% or more	83% or more	83% or more	

(4) Second speed volume efficiency verification tests

Second speed selection	Volume efficiency
Differential pressure : 100kgf/cm ² Revolutions : 20 rpm	96% or more

(5) Second speed operation tests

During the no-load tests under the running-in operating conditions for (3) and (4) above, make sure that the motor will change from the low speed over to the high speed when fluid pressures of 20kgf/cm² or more are applied from the second-speed selector pilot port (D-port).

Also, ensure that the motor changes over to the low speed at fluid pressures of 10kgf/cm² or less.

2) WHEN FIELD PERFORMANCE VERIFICATION TESTS ARE TO BE CONDUCTED WITHOUT USING A TESTING APPARATUS

※ Install the TM motor in the vehicle and provide piping, and then without mounting a crawler, carry out running-in operation, followed by performance tests.

(1) Condition for running-in operation

- ① 10 rpm, no-load pressure, one minute, clockwise/counterclockwise rotation.
- ② 20 rpm, no-load pressure, one minute, clockwise/counterclockwise rotation.

(2) Condition for performance tests

- ① Temperature : Working fluid temperature ---- 50 ± 5 °C
 Casing temperature of the ---- 40 to 80 °C
 reducer section

(3) No load driving pressure (Differential pressure)

First speed	10 rpm	20kgf/cm ²
Second speed	20 rpm	30kgf/cm ²

(4) Motor drainage amount measurement

Both first and second speeds	10 rpm	0.8 l /min below
------------------------------	--------	------------------