

**GROUP 2 SPECIFICATIONS**

**1. MAJOR COMPONENT**

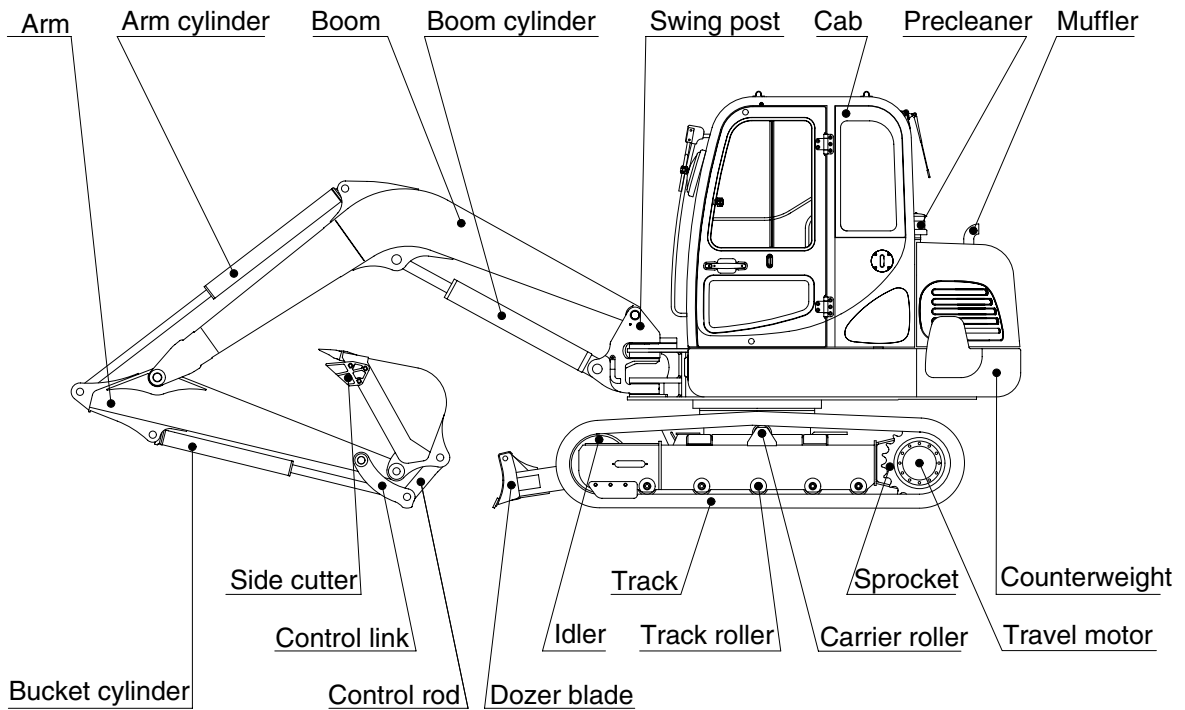
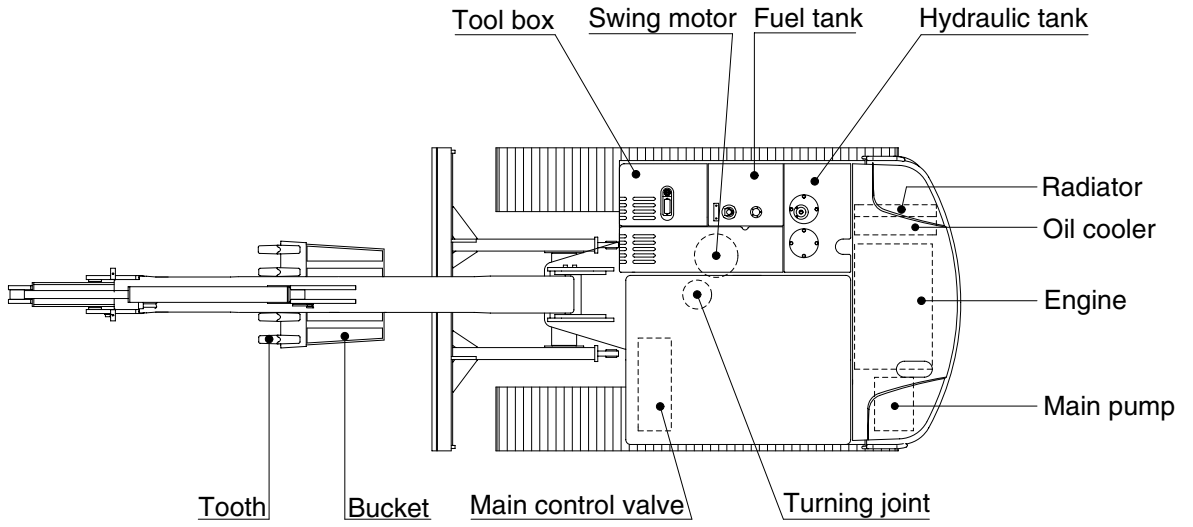

R5572SP01

## 2. SPECIFICATIONS

### 1) 3.0m( 9'10") MONO BOOM, 1.6m( 5' 3") ARM, WITH BOOM SWING POST

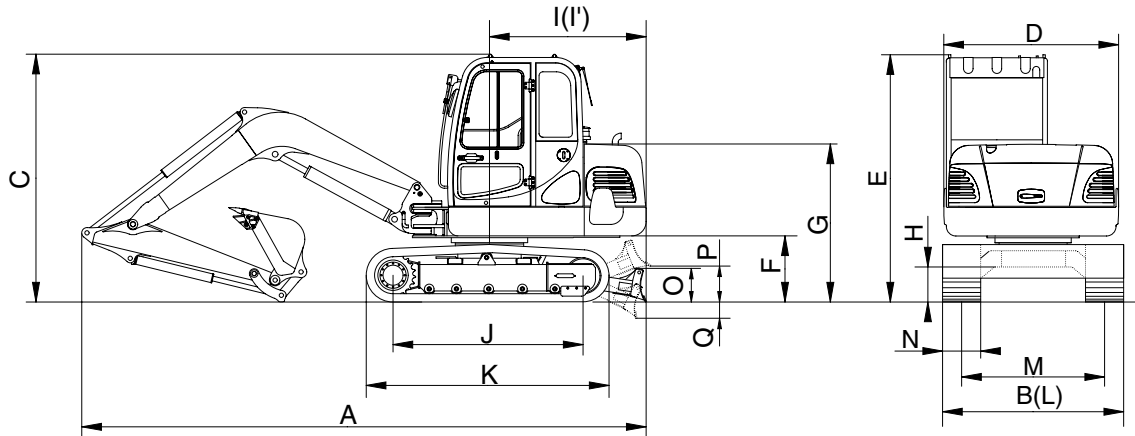

R5572SP02

Description		Unit	Specification
Operating weight		kg(lb)	5700(12570)
Bucket capacity(SAE heaped), standard		m <sup>3</sup> (yd <sup>3</sup> )	0.18(0.24)
Overall length	A	mm(ft-in)	5900(19' 4")
Overall width, with 400mm shoe	B		1920( 6' 4")
Overall height	C		2550( 8' 4")
Superstructure width	D		1830( 6' 0")
Overall height of cab	E		2550( 8' 4")
Ground clearance of counterweight	F		690( 2' 3")
Engine cover height	G		1650( 5' 5")
Minimum ground clearance	H		380( 1' 3")
Rear-end distance	I		1640( 5' 5")
Rear-end swing radius	I'		1650( 5' 5")
Distance between tumblers	J		1990( 6' 6")
Undercarriage length	K		2530( 8' 4")
Undercarriage width	L		1900( 6' 3")
Track gauge	M		1500( 4'11")
Track shoe width, standard	N		400(16")
Height of blade	O		350( 1' 2")
Ground clearance of blade up	P		420( 1' 5")
Depth of blade down	Q		440( 1' 5")
Travel speed(Low/high)			km/hr(mph)
Swing speed		rpm	9.6
Gradeability		Degree(%)	35(70)
Ground pressure(400mm shoe)		kgf/cm <sup>2</sup> (psi)	0.33(4.69)

### 3. WORKING RANGE

#### 1) 3.0m(9' 10") MONO BOOM WITH BOOM SWING POST

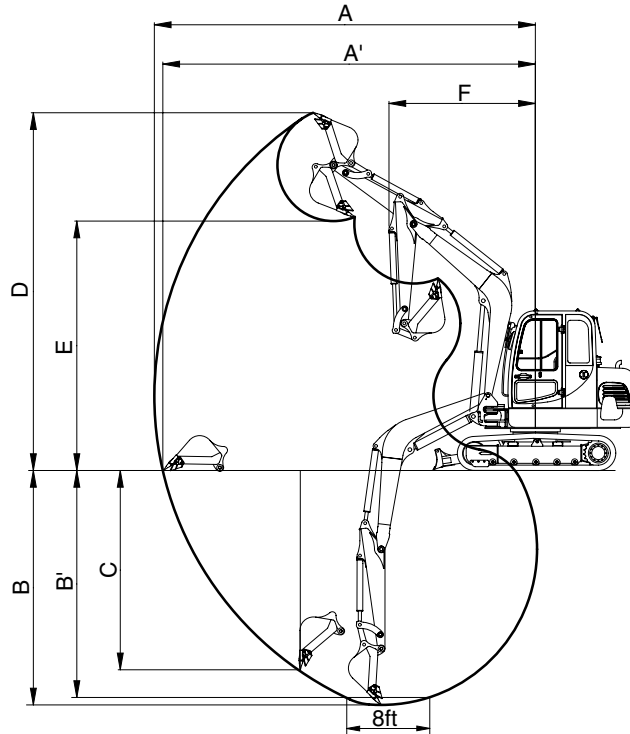

R5572SP03

Description		1.6m(5' 3") Arm
Max digging reach	A	6150mm (20' 2")
Max digging reach on ground	A'	6010mm (19' 9")
Max digging depth	B	3820mm (12' 6")
Max digging depth (8ft level)	B'	3420mm (11' 3")
Max vertical wall digging depth	C	3200mm (10' 6")
Max digging height	D	5780mm (18'12")
Max dumping height	E	4050mm (13' 3")
Min swing radius	F	2350mm ( 7' 9")
Boom swing radius(left/right)		80°/50°
Bucket digging force	SAE	33.5 kN
		3420 kgf
		7540 lbf
	ISO	37.7 kN
		3850 kgf
		8490 lbf
Arm digging force	SAE	25.3 kN
		2580 kgf
		5690 lbf
	ISO	28.4 kN
		2900 kgf
		6390 lbf

[ ] : Power boost

#### 4. WEIGHT











Item	kg	lb
Upperstructure assembly	2650	5840
Main frame weld assembly	680	1500
Engine assembly	280	620
Main pump assembly	30	70
Main control valve assembly	40	90
Swing motor assembly	70	160
Hydraulic oil tank assembly	80	180
Fuel tank assembly	60	130
Boom swing post	110	240
Counterweight	210	460
Cab assembly	280	620
Lower chassis assembly	2160	4750
Track frame weld assembly	720	1590
Swing bearing	100	220
Travel motor assembly	80	180
Turning joint	30	70
Track recoil spring	30	70
Idler	70	150
Carrier roller	10	20
Track roller	10	20
Sprocket	20	40
Track-chain assembly(400mm standard triple grouser shoe)	330	730
Dozer blade assembly	210	460
Front attachment assembly(3.0m boom,1.6m arm, 0.18m <sup>3</sup> SAE heaped bucket)	740	1630
3.0m boom assembly	260	570
1.6m arm assembly	140	310
0.18m <sup>3</sup> SAE heaped bucket	170	370
Boom cylinder assembly	60	130
Arm cylinder assembly	50	110
Bucket cylinder assembly	30	70
Bucket control link assembly	40	90
Dozer cylinder assembly	50	110
Boom swing cylinder assembly	40	90

## 5. LIFTING CAPACITIES

### 1) R55-7











(1) 3.0m( 9'10") boom, 1.6m( 5' 3") arm equipped with 0.18m<sup>3</sup>(SAE heaped) bucket and 400mm(16") triple grouser shoe, the dozer blade up with 210kg(460lb) counterweight.

-  : Rating over-front
-  : Rating over-side or 360 degree

Load point height		Load radius								At max. reach		
		2.0m(5ft)		3.0m(10ft)		4.0m(15ft)		5.0m(15ft)		Capacity		Reach
												m(ft)
5.0m (15ft)	kg lb									*950 *2090	*950 *2090	4.08 (13.4)
4.0m (15ft)	kg lb					*990 *2180	*990 *2180			*970 *2140	770 1700	5.04 (16.5)
3.0m (10ft)	kg lb					*1070 *2360	*1070 *2360			*1000 *2200	630 1390	5.57 (18.3)
2.0m (5ft)	kg lb	*2950 *6500	*2950 *6500	*1660 *3660	*1660 *3660	*1300 *2870	1070 2360	*1150 *2540	740 1630	*1050 *2310	570 1260	5.81 (19.1)
1.0m (5ft)	kg lb			*2320 *5110	1580 3480	*1580 *3480	1020 2250	*1260 *2780	710 1570	*1090 *2400	560 1230	5.82 (19.1)
Ground Line	kg lb	*2330 *5140	*2330 *5140	*2670 *5890	1510 3330	*1770 *3900	980 2160	*1340 *2950	690 1520	*1140 *2510	590 1300	5.60 (18.4)
-1.0m (-5ft)	kg lb	*3560 *7850	2980 6570	*2660 *5860	1490 3280	*1790 *3950	960 2120			*1170 *2580	680 1500	5.11 (16.8)
-2.0m (-5ft)	kg lb	*3780 *8330	3020 6660	*2300 *5070	1510 3330					*1140 *2510	940 2070	4.21 (13.8)
-3.0m (-10ft)	kg lb	*2100 *4630	*2100 *4630									

- Note
1. Lifting capacity are based on SAE J1097 and ISO 10567.
  2. Lifting capacity of the ROBEX series does not exceed 75% of tipping load with the machine on firm, level ground or 87% of full hydraulic capacity.
  3. The load point is a hook located on the back of the bucket.
  4. \*indicates load limited by hydraulic capacity.

2) 3.0m( 9'10") boom, 1.6m( 5' 3") arm equipped with 0.18m<sup>3</sup>(SAE heaped) bucket and 400mm(16") triple grouser shoe, the dozer blade down with 210kg(460lb) counterweight.

Load point height		Load radius								At max. reach		
		2.0m(5ft)		3.0m(10ft)		4.0m(15ft)		5.0m(15ft)		Capacity		Reach
												m(ft)
5.0m (15ft)	kg lb									*950 *2090	*950 *2090	4.08 (13.4)
4.0m (15ft)	kg lb					*990 *2180	*990 *2180			*970 *2140	770 1700	5.04 (16.5)
3.0m (10ft)	kg lb					*1070 *2360	*1070 *2360			*1000 *2200	630 1390	5.57 (18.3)
2.0m (5ft)	kg lb	*2950 *6500	*2950 *6500	*1660 *3660	*1660 *3660	*1300 *2870	1070 2360	*1150 *2540	740 1630	*1050 *2310	570 1260	5.81 (19.1)
1.0m (5ft)	kg lb			*2320 *5110	1580 3480	*1580 *3480	1020 2250	*1260 *2780	710 1570	*1090 *2400	560 1230	5.82 (19.1)
Ground Line	kg lb	*2330 *5140	*2330 *5140	*2670 *5890	1510 3330	*1770 *3900	980 2160	*1340 *2950	690 1520	*1140 *2510	590 1300	5.60 (18.4)
-1.0m (-5ft)	kg lb	*3560 *7850	2980 6570	*2660 *5860	1490 3280	*1790 *3950	960 2120			*1170 *2580	680 1500	5.11 (16.8)
-2.0m (-5ft)	kg lb	*3780 *8330	3020 6660	*2300 *5070	1510 3330					*1140 *2510	940 2070	4.21 (13.8)
-3.0m (-10ft)	kg lb	*2100 *4630	*2100 *4630									

## 6. BUCKET SELECTION GUIDE

### 1) GENERAL BUCKET

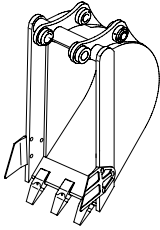
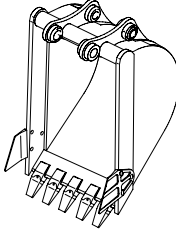
	
<p>0.07m<sup>3</sup> SAE heaped bucket</p>	<p>0.18m<sup>3</sup> SAE heaped bucket</p>

Capacity		Width		Weight	Recommendation
					3.0m ( 9'10" ) boom
SAE heaped	CECE heaped	Without side cutter	With side cutter		1.6m ( 5' 3" ) arm
0.07m <sup>3</sup> (0.09yd <sup>3</sup> )	0.06m <sup>3</sup> (0.08yd <sup>3</sup> )	315mm (12.4")	360mm (14.2")	84kg (185lb)	Applicable for materials with density of 1600kgf/m <sup>3</sup> (2700ib/yd <sup>3</sup> ) or less
0.18m <sup>3</sup> (0.24yd <sup>3</sup> )	0.15m <sup>3</sup> (0.20yd <sup>3</sup> )	705mm (27.8")	770mm (30.3")	137kg (300lb)	

## 7. UNDERCARRIAGE

### 1) TRACKS

X-leg type center frame is integrally welded with reinforced box-section track frames. The design includes dry tracks, lubricated rollers, idlers, sprockets, hydraulic track adjusters with shock absorbing springs and assembled track-type tractor shoes with triple grousers.

### 2) TYPES OF SHOES

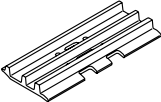
Model	Shapes		Triple grouser
			
R55-7	Shoe width	mm(in)	400(16)
	Operating weight	kg(lb)	5700(12570)
	Ground pressure	kgf/cm <sup>2</sup> (psi)	0.33(4.69)
	Overall width	mm(ft-in)	1900( 6' 3")

### 3) NUMBER OF ROLLERS AND SHOES ON EACH SIDE

Item	Quantity
Carrier rollers	1EA
Track rollers	5EA
Track shoes	40EA



## 8. SPECIFICATIONS FOR MAJOR COMPONENTS

### 1) ENGINE

Item	Specification
Model	Yanmar 4TNV94L
Type	4-cycle diesel engine, low emission
Cooling method	Water cooling
Number of cylinders and arrangement	4 cylinders, in-line
Firing order	1-3-4-2
Combustion chamber type	Direct injection type
Cylinder bore × stroke	94 × 110mm(3.70" × 4.33")
Piston displacement	3054cc(186cu in)
Compression ratio	19 : 1
Rated gross horse power(SAE J1995)	53Hp at 2200rpm(40kW at 2200rpm)
Maximum torque at 1400rpm	20.6kgf · m(149lbf · ft)
Engine oil quantity	9.2 l (2.4U.S. gal)
Dry weight	260kg(573lb)
High idling speed	2400+ 50rpm
Low idling speed	1050 ± 100rpm
Rated fuel consumption	167.7g/Hp · hr at 2200rpm
Starting motor	12V-3.0kW
Alternator	12V-55A
Battery	1 × 12V × 100Ah

### 2) MAIN PUMP

Item	Specification
Type	Variable displacement tandem axis piston pumps
Capacity	2 × 25cc/rev
Maximum pressure	220kgf/cm <sup>2</sup> (3130psi)
Rated oil flow	2 × 55 l /min (14.5U.S. gpm/ 12U.K. gpm)
Rated speed	2200rpm

### 3) GEAR PUMP

Item	Specification
Type	Fixed displacement gear pump single stage
Capacity	16.2/4.5cc/rev
Maximum pressure	220/30kgf/cm <sup>2</sup> (3130/430psi)
Rated oil flow	35.6/9.9 l /min(9.4/2.6U.S. gpm/7.8/2.2U.K. gpm)

### 4) MAIN CONTROL VALVE

Item	Specification
Type	Sectional, 10 spools+1 option
Operating method	Hydraulic pilot system+Mechanical control system
Main relief valve pressure	220kgf/cm <sup>2</sup> (3130psi)
Overload relief valve pressure	240kgf/cm <sup>2</sup> (3410psi)

### 5) SWING MOTOR

Item	Specification
Type	Fixed displacement axial piston motor
Capacity	28.87cc/rev
Relief pressure	200kgf/cm <sup>2</sup> (2840psi)
Braking system	Automatic, spring applied hydraulic released
Braking torque	14kgf · m(101lb · ft)
Brake release pressure	20~40kgf/cm <sup>2</sup> (284~570psi)
Reduction gear type	2 - stage planetary
Swing speed	9.6rpm

### 6) TRAVEL MOTOR

Item	Specification
Type	Variable displacement axial piston motor
Relief pressure	220kgf/cm <sup>2</sup> (3130psi)
Reduction gear type	2-stage planetary
Braking system	Automatic, spring applied hydraulic released
Brake release pressure	9kgf/cm <sup>2</sup> (128psi)
Braking torque	8.4kgf · m(61lb · ft)

## 7) REMOTE CONTROL VALVE

Item		Specification
Type		Pressure reducing type
Operating pressure	Minimum	5kgf/cm <sup>2</sup> (71psi)
	Maximum	20kgf/cm <sup>2</sup> (284psi)
Single operation stroke	Lever	6.5/8.5mm(0.26/0.33in)

## 8) CYLINDER

Item		Specification
Boom cylinder	Bore dia × Rod dia × Stroke	∅ 110 × ∅ 65 × 715mm
	Cushion	Extend only
Arm cylinder	Bore dia × Rod dia × Stroke	∅ 90 × ∅ 55 × 850mm
	Cushion	Extend and retract
Bucket cylinder	Bore dia × Rod dia × Stroke	∅ 80 × ∅ 50 × 660mm
	Cushion	-

※ Discoloration of cylinder rod can occur when the friction reduction additive of lubrication oil spreads on the rod surface.

※ Discoloration does not cause any harmful effect on the cylinder performance.

## 9) SHOE

Item	Width	Ground pressure	Link quantity	Overall width
R55-7	400mm(16")	0.33kgf/cm <sup>2</sup> (4.69psi)	40	1900mm( 6' 3")

## 10) BUCKET

Item		Capacity		Tooth quantity	Width	
		SAE heaped	CECE heaped		Without side cutter	With side cutter
R55-7	STD	0.18m <sup>3</sup> (0.24yd <sup>3</sup> )	0.15m <sup>3</sup> (0.20yd <sup>3</sup> )	5	705mm(27.8")	770mm(30.3")
	OPT	0.07m <sup>3</sup> (0.09yd <sup>3</sup> )	0.06m <sup>3</sup> (0.08yd <sup>3</sup> )	3	315mm(12.4")	360mm(14.2")

## 9. RECOMMENDED OILS

Use only oils listed below or equivalent.

Do not mix different brand oil.

Service point	Kind of fluid	Capacity l (U.S. gal)	Ambient temperature °C (°F)						
			-20 (-4)	-10 (14)	0 (32)	10 (50)	20 (68)	30 (86)	40 (104)
Engine oil pan	Engine oil	9.2(2.4)	SAE 30						
			SAE 10W						
			SAE 10W-30						
			SAE 15W-40						
Swing drive	Gear oil	1.5(0.4)	SAE 85W-140						
Final drive		1.2 × 2 (0.3 × 2)							
Hydraulic tank	Hydraulic oil	Tank: 70(18.5) System: 120(31.7)	ISO VG 32						
			ISO VG 46						
			ISO VG 68						
Fuel tank	Diesel fuel	120(31.7)	ASTM D975 NO.1						
			ASTM D975 NO.2						
Fitting (Grease nipple)	Grease	As required	NLGI NO.1						
			NLGI NO.2						
Radiator (Reservoir tank)	Mixture of antifreeze and water 50 : 50	10(2.6)	Ethylene glycol base permanent type						

**SAE** : Society of Automotive Engineers

**API** : American Petroleum Institute

**ISO** : International Organization for Standardization

**NLGI** : National Lubricating Grease Institute

**ASTM** : American Society of Testing and Material