

SECTION 3 HYDRAULIC SYSTEM

Group 1 Hydraulic Circuit	3-1
Group 2 Main Circuit	3-2
Group 3 Pilot Circuit	3-5
Group 4 Single Operation	3-10
Group 5 Combined Operation	3-22

SECTION 3 HYDRAULIC SYSTEM

GROUP 1 HYDRAULIC CIRCUIT

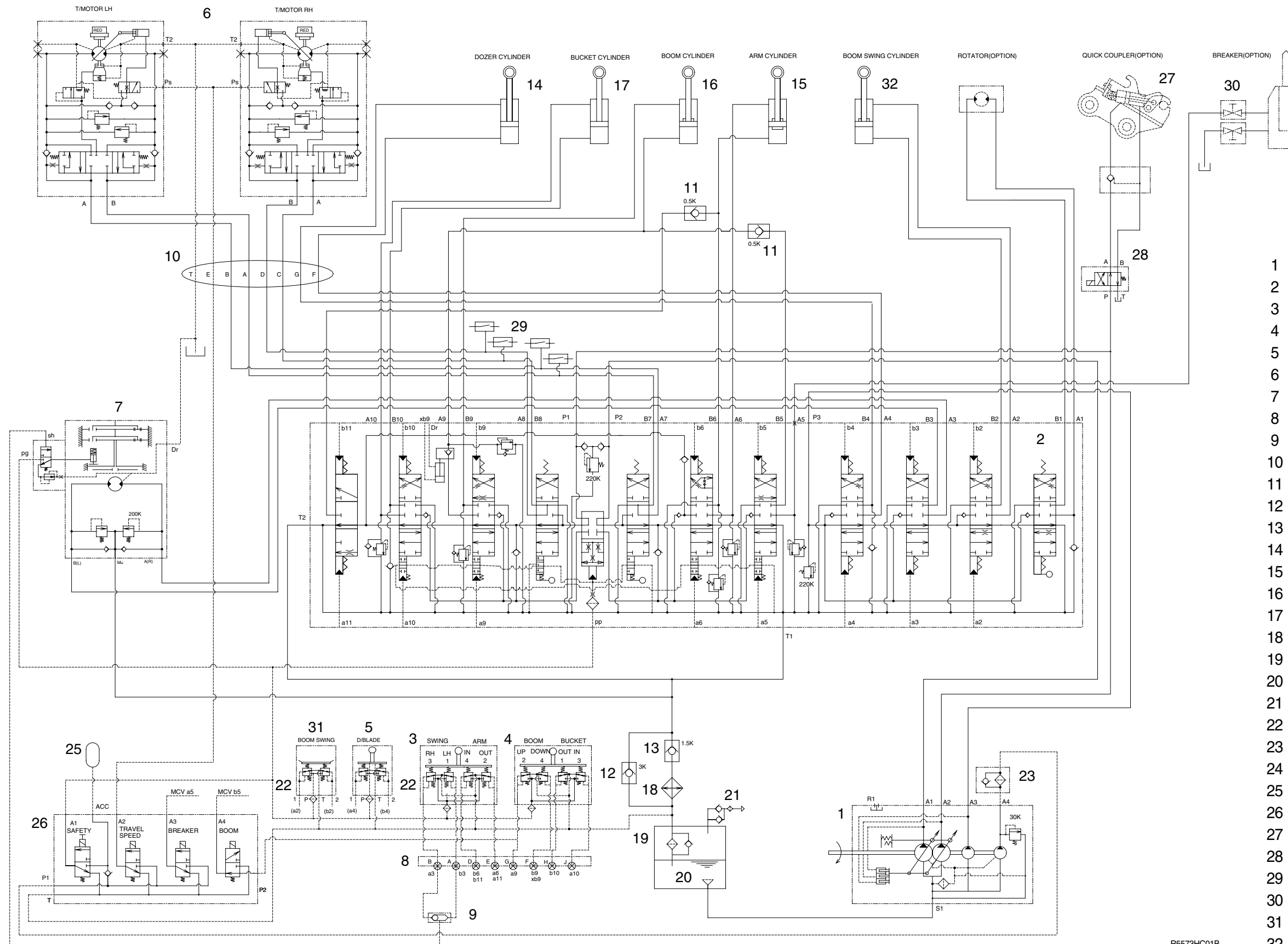

- 1 Main pump
- 2 Main control valve
- 3 RCV lever(LH)
- 4 RCV lever(RH)
- 5 RCV dozer
- 6 Travel motor
- 7 Swing motor
- 8 Terminal
- 9 Shuttle valve
- 10 Turning joint
- 11 Check valve
- 12 Check valve
- 13 Check valve
- 14 Dozer cylinder
- 15 Arm cylinder
- 16 Boom cylinder
- 17 Bucket cylinder
- 18 Hydraulic oil cooler
- 19 Return element
- 20 Suction strainer
- 21 Air breather
- 22 Last guard filter
- 23 Line filter
- 24 Solenoid valve
- 25 Accumulator
- 26 Solenoid valve
- 27 Coupler assy
- 28 Solenoid valve
- 29 Pressure switch
- 30 Stop valve assy
- 31 RCV pedal
- 32 Boom swing cylinder

R5573HC01B