



**YANMAR**  
M9961-02E050

---

# **YANMAR**

---

# **SERVICE MANUAL**

---

**INDUSTRIAL DIESEL ENGINE**

---

**MODEL 3TNV · 4TNV series**  
**(Direct Injection System)**

---

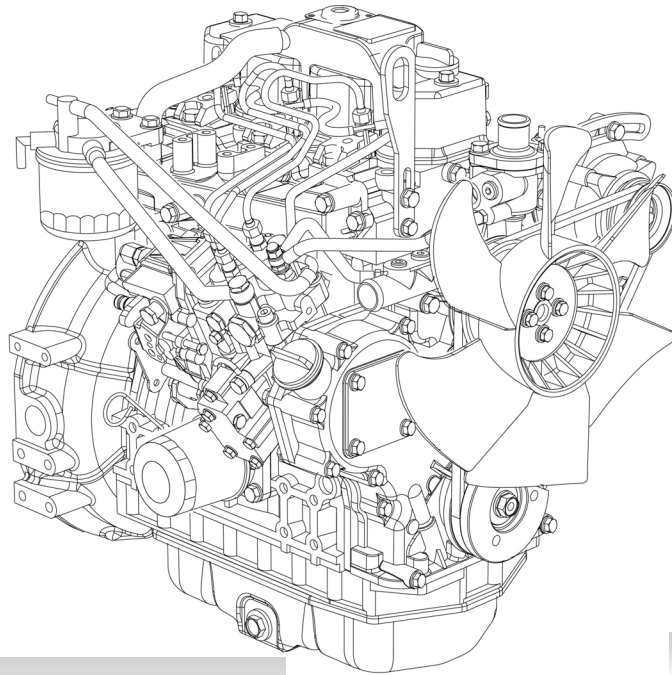

**4TNV94L**  
**4TNV98**  
**4TNV98T**

**3TNV82A**  
**3TNV84(T) · 4TNV84(T)**  
**3TNV88 · 4TNV88**

**4TNV106**  
**4TNV106T**



**YANMAR CO., LTD.**

# PREFACE

This manual describes the service procedures for the TNV series engines of indirect injection system that have been certified by the US EPA, California ARB and/or the 97/68/EC Directive for industrial use.

Please use this manual for accurate, quick and safe servicing of the said engine. Since the explanation in this manual assumes the standard type engine, the specifications and components may partially be different from the engine installed on individual work equipment (power generator, pump, compressor, etc.). Please also refer to the service manual for each work equipment for details.

The specifications and components may be subject to change for improvement of the engine quality without notice. If any modification of the contents described herein becomes necessary, it will be notified in the form of correction information each time.

## SAFETY LABELS

- Most accidents are caused by negligence of basic safety rules and precautions. For accident prevention, it is important to avoid such causes before development to accidents. Please read this manual carefully before starting repair or maintenance to fully understand safety precautions and appropriate inspection and maintenance procedures.  
Attempting at a repair or maintenance job without sufficient knowledge may cause an unexpected accident.
- It is impossible to cover every possible danger in repair or maintenance in the manual. Sufficient consideration for safety is required in addition to the matters marked . Especially for safety precautions in a repair or maintenance job not described in this manual, receive instructions from a knowledgeable leader.
- Safety marks used in this manual and their meanings are as follows:



**DANGER**

**DANGER**-indicates an imminently hazardous situation, which, if not avoided, **WILL** result in death or serious injury.



**WARNING**

**WARNING**-indicates a potentially hazardous situation, which, if not avoided, **COULD** result in death or serious injury.



**CAUTION**

**CAUTION**-indicates a potentially hazardous situation, which, if not avoided, **MAY** result in minor or moderate injury.

- **NOTICE**-indicates that if not observed, the product performance or quality may not be guaranteed.

# Safety Precautions

## (1) SERVICE AREA



- **Sufficient Ventilation**

Inhalation of exhaust fumes and dust particles may be hazardous to one's health. Running engines, welding, sanding, painting, and polishing tasks should be only done in well-ventilated areas.



- **Safe / Adequate Work Area**

The service area should be clean, spacious, level and free from holes in the floor, to prevent "slip" or "trip and fall" type accidents.



- **Bright, Safely Illuminated Area**

The work area should be well lit or illuminated in a safe manner. For work in enclosed or dark areas, a "drop cord" should be utilized. The drop cord must have a wire cage to prevent bulb breakage and possible ignition of flammable substances.



- **Safety Equipment**

Fire extinguisher(s), first aid kit and eye wash / shower station should be close at hand (or easily accessible) in case of an emergency.



## (2) WORK – WEAR (GARMENTS)

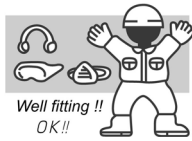

### ● Safe Work Clothing

Appropriate safety wear (gloves, special shoes/boots, eye/ear protection, head gear, harness', clothing, etc.) should be used/worn to match the task at hand. Avoid wearing jewelry, unbuttoned cuffs, ties or loose fitting clothes around moving machinery. A serious accident may occur if caught in moving/rotating machinery.

## (3) TOOLS



### ● Appropriate Lifting / Holding

When lifting an engine, use only a lifting device (crane, jack, etc.) with sufficient lifting capacity. Do not overload the device. Use only a chain, cable, or lifting strap as an attaching device. Do not use rope, serious injury may result.

To hold or support an engine, secure the engine to a support stand, test bed or test cart designed to carry the weight of the engine. Do not overload this device, serious injury may result.

Never run an engine without being properly secured to an engine support stand, test bed or test cart, serious injury may result.

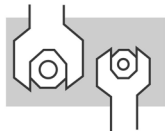

### ● Appropriate Tools

Always use tools that are designed for the task at hand. Incorrect usage of tools may result in damage to the engine and or serious personal injury.

## (4) GENUINE PARTS and MATERIALS



### ● Genuine Parts

Always use genuine YANMAR parts or YANMAR recommended parts and goods. Damage to the engine, shortened engine life and or personal injury may result.

## (5) FASTENER TORQUE

### WARNING

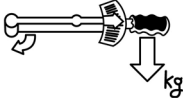

#### ● Torqueing Fasteners

Always follow the torque values and procedures as designated in the service manual. Incorrect values, procedures and or tools may cause damage to the engine and or personal injury.

## (6) Electrical

### WARNING

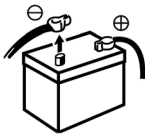

#### ● Short Circuits

Always disconnect the (-) Negative battery cable before working on the electrical system. An accidental "short circuit" may cause damage, fire and or personal injury. Remember to connect the (-) Negative battery cable (back onto the battery) last. Fasten the terminals tightly.

### WARNING



#### ● Charging Batteries

Charging wet celled batteries produces hydrogen gas. Hydrogen gas is extremely explosive. Keep sparks, open flame and any other form of ignition away. Explosion may occur causing severe personal injury.

### WARNING



#### ● Battery Electrolyte

Batteries contain sulfuric acid. Do NOT allow it to come in contact with clothing, skin and or eyes, severe burns will result.

## (7) WASTE MANAGEMENT

### CAUTION

Observe the following instructions with regard to hazardous waste disposal. Negligence of these will have a serious impact on environmental pollution concerns.

- 1) Waste fluids such as lube oil, fuel and coolant shall be carefully put into separate sealed containers and disposed of properly.
- 2) Do NOT dispose of waste materials irresponsibly by dumping them into the sewer, overland or into natural waterways.
- 3) Waste materials such as oil, fuel, coolant, solvents, filter elements and batteries, must be disposed of properly according to local ordinances. Consult the local authorities or reclamation facility.

## (8) FURTHER PRECAUTIONS

### WARNING



#### ● Fueling / Refueling

Keep sparks, open flames or any other form of ignition (match, cigarette, etc.) away when fueling/refueling the unit. *Fire and or an explosion may result.*

### WARNING



#### ● Hot Surfaces.

Do NOT touch the engine (or any of its components) during running or shortly after shutting it down. *Scalding / serious burns may result.* Allow the engine to cool down before attempting to approach the unit.

### WARNING



#### ● Rotating Parts

Be careful around moving/rotating parts. Loose clothing, jewelry, ties or tools may become entangled causing damage to the engine and or severe personal injury.

### WARNING



#### ● Preventing burns from scalding

- 1) Never open the radiator filler cap shortly after shutting the engine down.  
Steam and hot water will spurt out and seriously burn you. Allow the engine to cool down before attempt to open the filler cap.
- 2) Securely tighten the filler cap after checking the radiator.  
Steam can spurt out during engine running, if tightening loose.

## Precautions for Service Work

### (1) Precautions for Safety

Read the safety precautions given at the beginning of this manual carefully and always mind safety in work.

### (2) Preparation for Service Work

Preparation is necessary for accurate, efficient service work. Check the customer ledger file for the history of the engine.

- Preceding service date
- Period/operation hours after preceding service
- Problems and actions in preceding service
- Replacement parts expected to be required for service
- Recording form/check sheet required for service

### (3) Preparation before Disassembly

- Prepare general tools, special service tools, measuring instruments, oil, grease, non-reusable parts, and parts expected to be required for replacement.
- When disassembling complicated portions, put match-marks and other marks at places not adversely affecting the function for easy reassembly.

### (4) Precautions in Disassembly

- Each time a parts is removed, check the part installed state, deformation, damage, roughening, surface defect, etc.
- Arrange the removed parts orderly with clear distinction between those to be replaced and those to be used again.
- Parts to be used again shall be washed and cleaned sufficiently.
- Select especially clean locations and use clean tools for disassembly of hydraulic units such as the fuel injection pump.

### (5) Precautions for Inspection and Measurement

Inspect and measure parts to be used again as required to determine whether they are reusable or not.

### (6) Precautions for Reassembly

- Reassemble correct parts in correct order according to the specified standards (tightening torques, and adjustment standards). Apply oil important bolts and nuts before tightening when specified.
- Always use genuine parts for replacement.
- Always use new oil seals, O-rings, packing and cotter pins.
- Apply sealant to packing depending on the place where they are used. Apply of grease to sliding contact portions, and apply grease to oil seal lips.

### (7) Precautions for Adjustment and Check

Use measuring instruments for adjustment to the specified service standards.

## How to Read this Manual

### (1) Range of Operation Explanation

This manual explains the troubleshooting, installation/removal, replacement, disassemble/reassembly, inspection, adjustment and adjusting operation procedures for the TNV series engines with direct injection system.

Refer to the manufacturer's manual for each of the fuel injection pump, governor, starting motor and alternator except for their installation.

## (2) How to Read the Explanations

- An exploded view, sectional views, a system diagram, etc. are shown at the beginning of each section as required for easy understanding of the mounted states of the components.
- For the removal/installation of each part, the procedure is shown with the procedural step No. in the illustration.
- Precautions and key points for disassembly and reassembly of parts are described as **points**. In the explanation for each point, detailed operation method, information, standard and precautions are described.

### Description Example

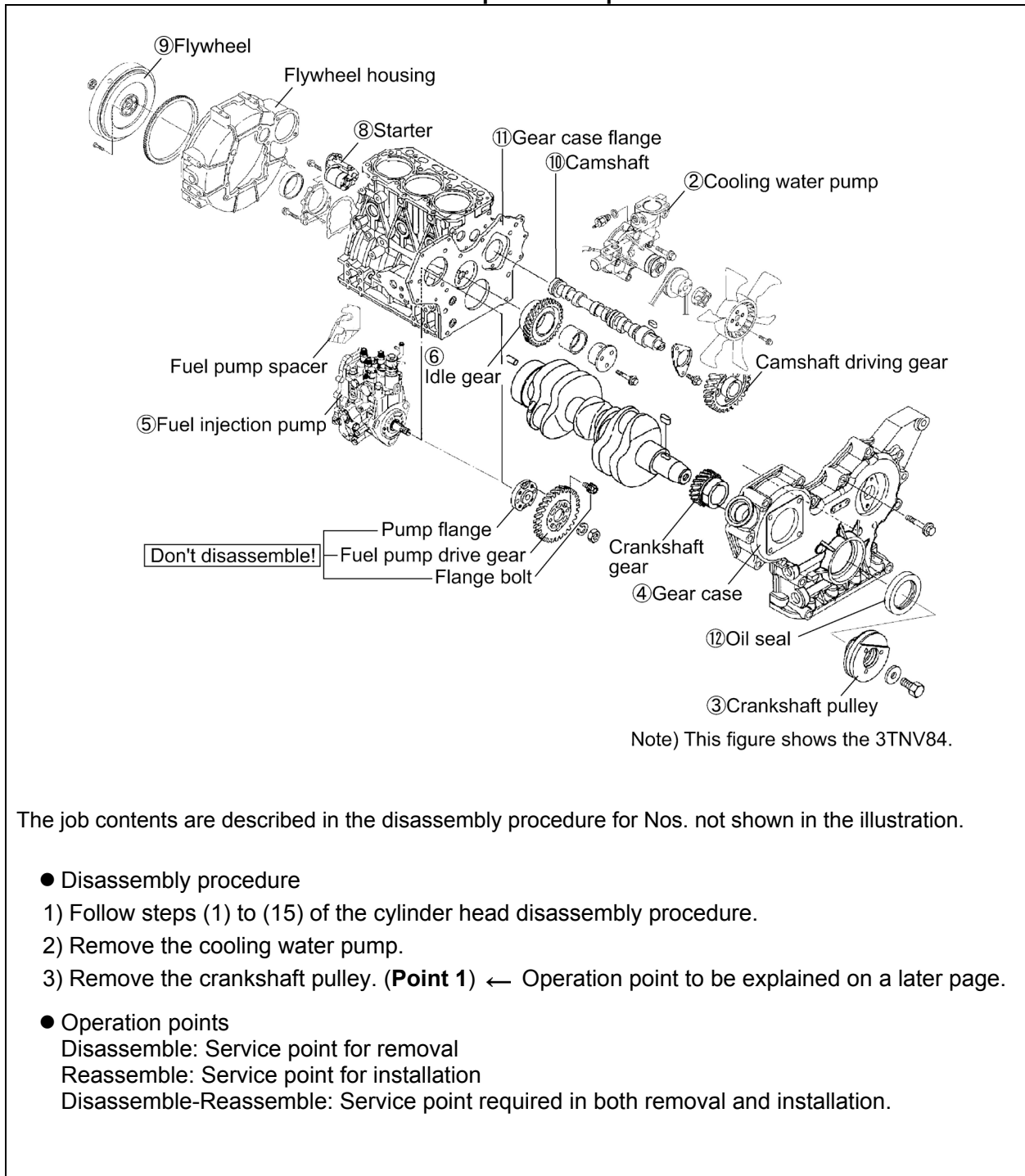

The job contents are described in the disassembly procedure for Nos. not shown in the illustration.

#### ● Disassembly procedure

- 1) Follow steps (1) to (15) of the cylinder head disassembly procedure.
- 2) Remove the cooling water pump.
- 3) Remove the crankshaft pulley. (**Point 1**) ← Operation point to be explained on a later page.

#### ● Operation points

Disassemble: Service point for removal

Reassemble: Service point for installation

Disassemble-Reassemble: Service point required in both removal and installation.

- Contents omitted in this manual

Though the following jobs are omitted in the explanation in this manual, they should be conducted in actual work:

- 3) Jacking up and lifting
- 4) Cleaning and washing of removed parts as required
- 5) Visual inspection

### (3) Definition of Terms

[NOTICE]: Instruction whose negligence is very likely to cause an accident. Always observe it.

Standard: Allowable range for inspection and adjustment.

Limit: The maximum or minimum value that must be satisfied during inspection or adjustment.

### (4) Abbreviations

Abbreviation	Meaning	Abbreviation	Meaning
Assy	assembly	T.D.C.	top dead center
Sub-Assy	sub-assembly	B.D.C.	bottom dead center
a.T.D.C	after top dead center	OS	oversize
b.T.D.C	before top dead center	US	undersize
STD	Standard	Min <sup>-1</sup>	revolutions per minute
IN	Intake	PS	Output (metric horsepower)
EX	Exhaust	T	Bolt/nut tightening torque

# CONTENTS

<b>1. General</b> .....	<b>1</b>
1.1 Engine Nomenclature .....	1
1.2 Specifications.....	1
1.3 Fuel Oil, Lubricating Oil and Cooling Water.....	14
1.3.1 Fuel oil.....	14
1.3.2 Lubricating oil .....	15
1.3.3 Cooling water .....	15
1.4 Engine External Views.....	16
1.5 Structural Description .....	17
1.6 Exhaust gas emission regulation.....	18
1.6.1 The Emission Standard in USA .....	18
1.6.2 Engine identification .....	19
1.6.3 Guarantee Conditions for the EPA Emission Standard .....	20
<b>2. Inspection and Adjustment</b> .....	<b>22</b>
2.1 Periodic Maintenance Schedule .....	22
2.2 Periodic Inspection and Maintenance Procedure .....	23
2.2.1 Check before Daily Operation .....	23
2.2.2 inspection after initial 50 hours operation .....	25
2.2.3 Inspection every 50 hours .....	28
2.2.4 Inspection every 250 hours or 3 months .....	32
2.2.5 Inspection every 500 hours or 6 months .....	35
2.2.6 Inspection every 1,000 hours or one year .....	37
2.2.7 Inspection every 2000 hours or 2 years .....	46
2.3 Adjusting the no-load maximum or minimum speed.....	49
2.4 Sensor Inspection .....	50
2.4.1 Oil pressure switch .....	50
2.4.2 Thermo switch .....	50
2.5 Water leak check in cooling water system.....	50
2.6 Radiator cap inspection .....	51
2.7 Thermostat Inspection .....	51
2.8 Adjusting Operation .....	52
2.9 Long storage.....	52
<b>3. TROUBLESHOOTING</b> .....	<b>53</b>
3.1 Preparation before troubleshooting .....	53
3.2 Quick Reference Table for Troubleshooting .....	54
3.3 Troubleshooting by measuring Compression Pressure.....	57

4. Disassembly, Inspection and Reassembly of Engines .....	59
4.1 Complete disassembly and reassembly .....	59
4.1.1 Introduction .....	59
4.1.2 Special service tools .....	60
4.1.3 Complete disassembly .....	65
4.1.4 Precautions before and during reassembly .....	69
4.1.5 Adjusting operation .....	69
4.2 Cylinder Head: Disassembly, Inspection and Reassembly.....	70
4.2.1 Components (2-valve cylinder head).....	70
4.2.2 Disassembly procedure: .....	70
4.2.3 Reassembly procedure: .....	71
4.2.4 Servicing points .....	72
4.2.5 Parts Inspection and measurement.....	76
4.2.6 Valve seat correction .....	80
4.2.7 Valve guide replacement .....	81
4.2.8 Valve stem seal replacement.....	82
4.3 Gear Train and Camshaft .....	83
4.3.1 Components .....	83
4.3.2 Disassembly procedure: .....	83
4.3.3 Reassembly procedure: .....	83
4.3.4 Servicing points .....	84
4.3.5 Parts inspection and measurement .....	87
4.3.6 Oil seal replacement (Gear case side) .....	89
4.3.7 Camshaft bushing replacement.....	89
4.4 Cylinder Block.....	90
4.4.1 Components .....	90
4.4.2 Disassembly procedure: .....	90
4.4.3 Reassembly procedure: .....	90
4.4.4 Servicing points .....	91
4.4.5 Parts inspection and measurement .....	95
4.4.6 Cylinder bore correction .....	106
4.4.7 Piston pin bushing replacement .....	107
4.4.8 Oil seal replacement (Flywheel housing side) .....	107



<b>5. LUBRICATION SYSTEM .....</b>	<b>108</b>
5.1 Lubrication System Diagram .....	108
5.2 Trochoid Pump Components .....	109
5.3 Disassembly(Reverse the procedure below for assembly) .....	109
5.4 Servicing Points .....	109
5.5 Parts Inspection and Measurement.....	110
5.5.1 Trochoid pump inspection and measurement.....	110
<b>6. COOLING SYSTEM.....</b>	<b>112</b>
6.1 Cooling Water System .....	112
6.2 Cooling Water Pump Components .....	112
6.3 Disassembly (Reverse the procedure below for assembly) .....	113
6.4 Servicing Points .....	113
<b>7. FUEL INJECTION PUMP/GOVERNOR.....</b>	<b>114</b>
7.1 Introduction .....	114
7.2 Fuel Injection Pump.....	114
7.2.1 Fuel system diagram .....	114
7.2.2 External view and components.....	115
7.2.3 Disassembly procedure: .....	115
7.2.4 Assembly procedure.....	116
7.2.5 Servicing points .....	116
<b>8. TURBOCHARGER: Disassembly, inspection and reassembly.....</b>	<b>118</b>
8.1 Structure and Functions.....	118
8.1.1 Main specifications .....	118
8.1.2 Construction .....	118
8.1.3 Structural and functional outline .....	119
8.1.4 Components .....	120
8.2 Service Standards and Tightening Torque .....	121
8.2.1 Service standards.....	121
8.2.2 Tightening torque.....	122
8.3 Periodic Inspection Procedure.....	123
8.3.1 Periodic inspection intervals .....	123
8.3.2 Inspection procedure.....	124
8.3.3 Waste gate valve adjustment procedure .....	125
8.4 Disassembly Procedure.....	127
8.4.1 Preparation for disassembly .....	127
8.4.2 Inspection before disassembly .....	128
8.4.3 Disassembly .....	128

8.5 Washing and Inspection procedure .....	130
8.5.1 Washing .....	130
8.5.2 Inspection procedure.....	131
8.6 Reassembly Procedure .....	134
8.6.1 Preparation for reassembly.....	134
8.6.2 Reassembly .....	134
8.7 Handling after Disassembly and Reassembly .....	137
8.7.1 Instructions for turbocharger installation.....	137
8.8 Troubleshooting .....	138
8.8.1 Excessively exhaust smoke .....	138
8.8.2 White smoke generation.....	138
8.8.3 Sudden oil decrease.....	139
8.8.4 Decrease in output .....	139
8.8.5 Poor (slow) response (starting) of turbocharger .....	139
8.8.6 Abnormal sound or vibration.....	139
<b>9. STARTING MOTOR.....</b>	<b>140</b>
9.1 For 4TNV94L/ 98 .....	140
9.1.1 Specifications .....	140
9.1.2 Components .....	141
9.1.3 Troubleshooting.....	142
9.1.4 Names of parts and disassembly procedure .....	143
9.1.5 Inspection and Maintenance .....	147
9.1.6 Service standards.....	152
9.1.7 Assembly.....	153
9.1.8 Characteristic test.....	155
9.2 For 4TNV106(T) .....	156
9.2.1 Specifications .....	156
9.2.2 Congiguration drawing .....	156
9.2.3 Troubleshooting .....	157
9.2.4 Component names and disassembly procedure .....	158
9.2.5 Disassembly procedure.....	159
9.2.6 Inspection and maintenance .....	167
9.2.7 Assembly.....	173
9.2.8 Adjustment .....	174
9.2.9 Service standards.....	175

<b>10. ALTERNATOR</b> .....	<b>176</b>
10.1 The 40A Alternator for 3TNV84 and other models.....	176
10.1.1 Components.....	176
10.1.2 Specifications.....	177
10.1.3 Wiring diagram.....	177
10.1.4 Standard output characteristics.....	178
10.1.5 Inspection.....	178
10.2 Troubleshooting.....	179
<b>11. ELECTRIC WIRING</b> .....	<b>180</b>
11.1 Electric Wiring Diagram.....	180
11.2 PRECAUTION ON ELECTRIC WIRING.....	181
11.2.1 Alternator.....	181
11.2.2 Starter.....	182
11.2.3 Current limiter.....	183
11.2.4 Section area and resistance of electric wire.....	184
<b>12. SERVICE STANDARDS</b> .....	<b>185</b>
12.1 Engine Tuning.....	185
12.2 Engine Body.....	186
12.2.1 Cylinder head.....	186
12.2.2 Gear train and camshaft.....	189
12.2.3 Cylinder block.....	190
12.3 Lubricating Oil System (Trochoid Pump).....	195
12.3.1 Outside clearance of outer rotor.....	195
12.3.2 Side clearance of outer rotor.....	195
12.3.3 Inside clearance of inner rotor.....	195
12.3.4 Rotor shaft clearance.....	195
<b>13. TIGHTENING TORQUE for BOLTS and NUTS</b> .....	<b>196</b>
13.1 Tightening Torques for Main Bolts and Nuts.....	196
13.2 Tightening Torques for Standard Bolts and Nuts.....	197

# 1. General

## 1.1 Engine Nomenclature

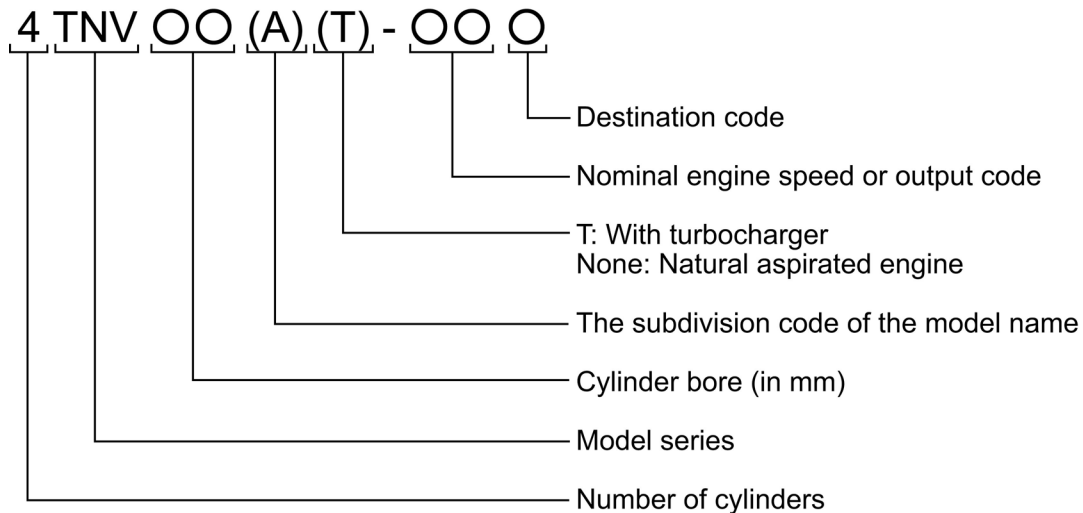

The engine specification class

Classification	Load	Engine speed	Available engine speed (min <sup>-1</sup> )
CL	Constant load	Constant speed	1500/1800
VM	Variable load	Variable speed	2000-3000

※ The engine specification class (CL or VM) is described in the specifications table.

## 1.2 Specifications

NOTE:

- 1) The information described in the engine specifications tables (the next page and after) is for "standard" engine. To obtain the information for the engine installed in each machine unit, refer to the manual provided by the equipment manufacturer.
- 2) Engine rating conditions are as follows (SAE J1349, ISO 3046/1)
  - Atmospheric condition: Room temp. 25°C, Atmospheric press. 100 kPa (750mm Hg), Relative humidity 30%
  - Fuel temp: 25°C (Fuel injection pump inlet)
  - With cooling fan, air cleaner, exhaust silencer (Yanmar standard parts)
  - After running-in hours. Output allowable deviation: ±3%

## (1) 3TNV82A

Engine name		Unit	3TNV82A								
Engine specification class		-	CL	VM							
Type		-	Vertical, in-line, 4-cycle, water-cooled diesel engine								
Combustion chamber		-	Direct injection								
Number of cylinders		-	3								
Cylinder bore×stroke		mm×mm	82×84								
Displacement		L	1.331								
Continuous rating	Revolving speed	Min <sup>-1</sup>	1500	1800	-						
	Output	kW (hp)	9.9 (13.5)	12.0 (16.3)	-						
Rated output	Revolving speed	Min <sup>-1</sup>	1500	1800	2000	2200	2400	2500	2600	2800	3000
	Output	kW (hp)	11.0 (14.9)	13.2 (17.9)	14.6 (19.9)	16.0 (21.8)	17.5 (23.8)	18.2 (24.8)	19.0 (25.8)	20.4 (27.8)	21.9 (29.8)
Max. no-load speed (±25)		min <sup>-1</sup>	1600	1895	2180	2375	2570	2675	2780	2995	3180
Ignition order		-	1-3-2-1(No.1 cylinder on flywheel side)								
Power take off		-	Flywheel								
Direction of rotation		-	Counterclockwise (viewed from flywheel)								
Cooling system		-	Radiator								
Lubrication system		-	Forced lubrication with trochoid pump								
Starting system		-	Electric								
Applicable fuel		-	Diesel oil-ISO 8217 DMA, BS 2869 A1 or A2 (Cetane No.45 min.)								
Applicable lubricant		-	API grade class CD or CF								
Lubricant capacity (oil pan) *	Total	L	3.6						5.5		
	Effective	L	1.2						2.2		
Coolant water capacity (engine only)		L	1.8								
Engine Dimensions ** (with flyw Crankshaft V pulley diameter & heel housing)	Overall length	mm	553			528					
	Overall width	mm	489								
	Overall height	mm	565								
Engine mass (dry) ** (with flywheel housing)		kg	138			128					
Cooling fan (std.)		mm	335 mm O/D, 6 blades pusher type								
Fun V pulley diameter (std.)		mm	120×90			110×110					

\* Engine oil capacity may differ from the above depending on an engine installed on a machine unit.

\*\* Engine mass and dimensions without radiator

## (2) 3TNV84

Engine name		Unit	3TNV84								
Engine specification class		-	CL	VM							
Type		-	Vertical, in-line, 4-cycle, water-cooled diesel engine								
Combustion chamber		-	Direct injection								
Number of cylinders		-	3								
Cylinder borexstroke		mmxmm	84x90								
Displacement		L	1.496								
Continuous rating	Revolving speed	Min <sup>-1</sup>	1500	1800	-						
	Output	kW (hp)	11.3 (15.3)	13.5 (18.3)	-						
Rated output	Revolving speed	Min <sup>-1</sup>	1500	1800	2000	2200	2400	2500	2600	2800	3000
	Output	kW (hp)	12.4 (16.8)	14.8 (20.1)	16.4 (22.3)	18.1 (24.6)	19.7 (26.8)	20.5 (27.9)	21.3 (29.0)	23.0 (31.3)	24.6 (33.5)
Max. no-load speed (±25)		min <sup>-1</sup>	1600	1895	2180	2400	2590	2690	2810	2995	3210
Ignition order		-	1-3-2-1(No.1 cylinder on flywheel side)								
Power take off		-	Flywheel								
Direction of rotation		-	Counterclockwise (viewed from flywheel)								
Cooling system		-	Radiator								
Lubrication system		-	Forced lubrication with trochoid pump								
Starting system		-	Electric								
Applicable fuel		-	Diesel oil-ISO 8217 DMA, BS 2869 A1 or A2 (Cetane No.45 min.)								
Applicable lubricant		-	API grade class CD								
Lubricant capacity (oil pan) *	Total	L	6.7								
	Effective	L	1.9								
Coolant water capacity (engine only)		L	1.8								
Engine dimensions ** (with flywheel housing)	Overall length	mm	589	564							
	Overall width	mm	486								
	Overall height	mm	622								
Engine mass (dry) ** (with flywheel housing)		kg	161	155							
Cooling fan (std.)		mm	335 mm O/D, 6 blades pusher type								
Crankshaft V pulley diameter & Fun V pulley diameter (std.)		mm	120x90	110x110							

\* Engine oil capacity may differ from the above depending on an engine installed on a machine unit.

\*\* Engine mass and dimensions without radiator

## (3) 3TNV84T

Engine name		Unit	3TNV84T								
Engine specification class		-	CL	VM							
Type		-	Vertical, in-line, 4-cycle, water-cooled diesel engine								
Combustion chamber		-	Direct injection								
Number of cylinders		-	3								
Cylinder borexstroke		mmxmm	84x90								
Displacement		L	1.496								
Continuous rating	Revolving speed	Min <sup>-1</sup>	1500	1800	-						
	Output	kW (hp)	14.0 (19.0)	16.5 (22.5)	-						
Rated output	Revolving speed	Min <sup>-1</sup>	1500	1800	2000	2200	2400	2500	2600	2800	3000
	Output	kW (hp)	15.8 (21.5)	18.8 (25.5)			25.0 (34.0)	25.9 (35.2)	26.8 (36.5)	29.1 (39.5)	30.9 (42.0)
Max. no-load speed (±25)		min <sup>-1</sup>	1600	1895			2590	2700	2810	2995	3210
Ignition order		-	1-3-2-1(No.1 cylinder on flywheel side)								
Power take off		-	Flywheel								
Direction of rotation		-	Counterclockwise (viewed from flywheel)								
Cooling system		-	Radiator								
Lubrication system		-	Forced lubrication with trochoid pump								
Starting system		-	Electric								
Applicable fuel		-	Diesel oil-ISO 8217 DMA, BS 2869 A1 or A2 (cetane No.45 min.)								
Applicable lubricant		-	API grade class CD or CF								
Lubricant capacity (oil pan) *	Total	L	6.7								
	Effective	L	1.9								
Coolant water capacity (engine only)		L	2.0								
Engine dimensions ** (with flywheel housing)	Overall length	mm	589	564							
	Overall width	mm	486								
	Overall height	mm	622								
Engine mass (dry) ** (with flywheel housing)		kg	161	155							
Cooling fan (std.)		mm	350 mm O/D, 6 blades pusher type								
Crankshaft V pulley diameter & Fun V pulley diameter (std.)		mm	120x90	110x110							

\* Engine oil capacity may differ from the above depending on an engine installed on a machine unit.

\*\* Engine mass and dimensions without radiator

## (4) 3TNV88

Engine name		Unit	3TNV88								
Engine specification class		-	CL	VM							
Type		-	Vertical, in-line, 4-cycle, water-cooled diesel engine								
Combustion chamber		-	Direct injection								
Number of cylinders		-	3								
Cylinder borexstroke		mm× mm	88×90								
Displacement		L	1.642								
Continuous rating	Revolving speed	Min <sup>-1</sup>	1500	1800	-						
	Output	kW (hp)	12.3 (16.7)	14.8 (20.1)	-						
Rated output	Revolving speed	Min <sup>-1</sup>	1500	1800	2000	2200	2400	2500	2600	2800	3000
	Output	kW (hp)	13.5 (18.4)	16.3 (22.1)	18.0 (24.5)	19.9 (27.0)	21.6 (29.4)	22.6 (30.7)	23.5 (31.9)	25.2 (34.2)	27.1 (36.8)
Max. no-load speed (±25)		min <sup>-1</sup>	1600	1895	2180	2400	2590	2700	2810	2995	3210
Ignition order		-	1-3-2-1(No.1 cylinder on flywheel side)								
Power take off		-	Flywheel								
Direction of rotation		-	Counterclockwise (viewed from flywheel)								
Cooling system		-	Radiator								
Lubrication system		-	Forced lubrication with trochoid pump								
Starting system		-	Electric								
Applicable fuel		-	Diesel oil-ISO 8217 DMA, BS 2869 A1 or A2 (Cetane No.45 min.)								
Applicable lubricant		-	API grade class CD or CF								
Lubricant capacity (oil pan) *	Total	L	4.7						7.2		
	Effective	L	1.8						3.5		
Coolant water capacity (engine only)		L	2.0								
Engine dimensions ** (with flywheel housing)	Overall length	mm	589			564					
	Overall width	mm	486								
	Overall height	mm	622								
Engine mass (dry) ** (with flywheel housing)		kg	155								
Cooling fan (std.)		Mm	350 mm O/D, 6 blades pusher type								
Crankshaft V pulley diameter & Fun V pulley diameter (std.)		Mm	120×90			120×90					

\* Engine oil capacity may differ from the above depending on an engine installed on a machine unit.

\*\* Engine mass and dimensions without radiator



## (5) 4TNV84

Engine name		Unit	4TNV84								
Engine specification class		-	CL	VM							
Type		-	Vertical, in-line, 4-cycle, water-cooled diesel engine								
Combustion chamber		-	Direct injection								
Number of cylinders		-	4								
Cylinder borexstroke		mm× mm	84×90								
Displacement		L	1.995								
Continuous Rating	Revolving speed	Min <sup>-1</sup>	1500	1800	-						
	Output	kW (hp)	14.9 (20.3)	17.7 (24.1)	-						
Rated output	Revolving speed	Min <sup>-1</sup>	1500	1800	2000	2200	2400	2500	2600	2800	3000
	Output	kW (hp)	16.4 (22.3)	19.5 (26.5)	21.9 (29.8)	24.1 (32.8)	26.3 (35.8)	27.4 (37.3)	28.5 (38.7)	30.7 (41.7)	32.9 (44.7)
Max. no-load speed (±25)		min <sup>-1</sup>	1600	1895	2180	2400	2590	2700	2810	2995	3210
Ignition order		-	1-3-4-2-1(No.1 cylinder on flywheel side)								
Power take off		-	Flywheel								
Direction of rotation		-	Counterclockwise (viewed from flywheel)								
Cooling system		-	Radiator								
Lubrication system		-	Forced lubrication with trochoid pump								
Starting system		-	Electric								
Applicable fuel		-	Diesel oil-ISO 8217 DMA, BS 2869 A1 or A2 (cetane No.45 min.)								
Applicable lubricant		-	API grade class CD or CF								
Lubricant capacity (oil pan) *	Total	L	7.4								
	Effective	L	2.3								
Coolant water capacity (engine only)		L	2.7								
Engine dimensions ** (with flywheel housing)	Overall length	mm	683	658							
	Overall width	mm	498.5								
	Overall height	mm	617								
Engine mass (dry) ** (with flywheel housing)		kg	183	170							
Cooling fan (std.)		mm	370 mm O/D, 6 blades pusher type								
Crankshaft V pulley diameter & Fun V pulley diameter (std.)		mm	120×90	110×110							

\* Engine oil capacity may differ from the above depending on an engine installed on a machine unit.

\*\* Engine mass and dimensions without radiator

## (6) 4TNV84T

Engine name		Unit	4TNV84T							
Engine specification class		-	CL	VM						
Type		-	Vertical, in-line, 4-cycle, water-cooled diesel engine							
Combustion chamber		-	Direct injection							
Number of cylinders		-	4							
Cylinder borexstroke		mmxmm	84x90							
Displacement		L	1.995							
Continuous rating	Revolving speed	Min <sup>-1</sup>	1500	1800	-					
	Output	KW (hp)	19.1 (26.0)	24.3 (33.0)	-					
Rated output	Revolving speed	Min <sup>-1</sup>	1500	1800	2000	2200	2400	2600	2800	3000
	Output	KW (hp)	21.3 (29.0)	26.9 (36.5)	27.9 (38.0)	30.5 (41.5)	33.5 (45.5)	35.7 (48.5)	38.6 (52.5)	41.2 (56.0)
Max. no-load speed (±25)		min <sup>-1</sup>	1600	1895	2180	2400	2590	2810	2995	3210
Ignition order		-	1-3-4-2-1(No.1 cylinder on flywheel side)							
Power take off		-	Flywheel							
Direction of rotation		-	Counterclockwise (viewed from flywheel)							
Cooling system		-	Radiator							
Lubrication system		-	Forced lubrication with trochoid pump							
Starting system		-	Electric							
Applicable fuel		-	Diesel oil-ISO 8217 DMA, BS 2869 A1 or A2 (Cetane No.45 min.)							
Applicable lubricant		-	API grade class CD or CF							
Lubricant capacity (oil pan) *	Total	L	7.4							
	Effective	L	3.4							
Coolant water capacity (engine only)		L	2.7							
Engine dimensions **	Overall length	mm	683	649						
	Overall width	mm	498.5							
	Overall height	mm	713							
Engine mass (dry) ** (with flywheel housing)		kg	183	170						
Cooling fan (std.)		mm	370 mm O/D, 6 blades pusher type							
Crankshaft V pulley diameter & Fun V pulley diameter (std.)		mm	120x90	110x110						

\* Engine oil capacity may differ from the above depending on an engine installed on a machine unit.

\*\* Engine mass and dimensions without radiator

## (7) 4TNV88

Engine name		Unit	4TNV88								
Engine specification class		-	CL	VM							
Type		-	Vertical, in-line, 4-cycle, water-cooled diesel engine								
Combustion chamber		-	Direct injection								
Number of cylinders		-	4								
Cylinder borexstroke		mmxmm	88x90								
Displacement		L	2.190								
Continuous rating	Revolving speed	Min <sup>-1</sup>	1500	1800	-						
	Output	kW (hp)	16.4 (22.3)	19.6 (26.7)	-						
Rated output	Revolving speed	Min <sup>-1</sup>	1500	1800	2000	2200	2400	2500	2600	2800	3000
	Output	kW (hp)	18.0 (24.5)	21.6 (29.4)	24.1 (32.7)	26.5 (36.0)	28.8 (39.2)	30.1 (40.9)	31.3 (42.5)	33.7 (45.8)	35.4 (48.1)
Max. no-load speed (±25)		min <sup>-1</sup>	1600	1895	2180	2400	2590	2700	2810	2995	3210
Ignition order		-	1-3-4-2-1(No.1 cylinder on flywheel side)								
Power take off		-	Flywheel								
Direction of rotation		-	Counterclockwise (viewed from flywheel)								
Cooling system		-	Radiator								
Lubrication system		-	Forced lubrication with trochoid pump								
Starting system		-	Electric								
Applicable fuel		-	Diesel oil-ISO 8217 DMA, BS 2869 A1 or A2 (cetane No.45 min.)								
Applicable lubricant		-	API grade class CD or CF								
Lubricant capacity (oil pan) *	Total	L	5.8						8.6		
	Effective	L	2.3						4.2		
Coolant water capacity (engine only)		L	2.7								
Engine dimensions ** (with wheel housing)	Overall length	mm	683	658							
	Overall width	mm	498.5								
	Overall height	mm	618								
Engine mass (dry) ** (with flywheel housing)		kg	183	170							
Cooling fan (std.)		mm	370 mm O/D, 6 blades pusher type								
Crankshaft V pulley diameter & Fun V pulley diameter (std.)		mm	120x90	110x110							

\* Engine oil capacity may differ from the above depending on an engine installed on a machine unit.

\*\* Engine mass and dimensions without radiator

## (8) 4TNV94L

Engine name		Unit	4TNV94L					
Engine specification class		-	CL			VM		
Type		-	Vertical, in-line, 4-cycle, water-cooled diesel engine					
Combustion chamber		-	Direct injection					
Number of cylinders		-	4					
Cylinder bore×stroke		mm×mm	94×110					
Displacement		L	3.053					
Continuous rating	Revolving speed	Min <sup>-1</sup>	1500	1800	-			
	Output	kW (hp)	26.1 (35.5)	31.3 (42.5)	-			
Rated output	Revolving speed	Min <sup>-1</sup>	1500	1800	2000	2200	2400	2500
	Output	kW (hp)	29.1 (39.5)	34.6 (47.0)	35.3 (48.0)	38.2 (52.0)	41.6 (56.5)	43.0 (58.5)
Max. no-load speed (±25)		min <sup>-1</sup>	1600	1895	2180	2400	2590	2700
Ignition order		-	1-3-4-2-1(No.1 cylinder on flywheel side)					
Power take off		-	Flywheel					
Direction of rotation		-	Counterclockwise (viewed from flywheel)					
Cooling system		-	Radiator					
Lubrication system		-	Forced lubrication with trochoid pump					
Starting system		-	Electric					
Applicable fuel		-	Diesel oil-ISO 8217 DMA, BS 2869 A1 or A2 (Cetane No.45 min.)					
Applicable lubricant		-	API grade class CD or CF					
Lubricant capacity (oil pan) *	Total	L	10.2					
	Effective	L	4.5					
Coolant water capacity (engine only)		L	4.2					
Engine dimensions ** (with flywheel housing)	Overall length	mm	719					
	Overall width	mm	498					
	Overall height	mm	717					
Engine mass (dry) ** (with flywheel housing)		kg	245 (equivalent to SAE#3)			235 (equivalent to SAE#4)		
Cooling fan (std.)		mm	410 mm O/D, 6 blades pusher type					
Crankshaft V pulley diameter & Fun V pulley diameter (std.)		mm	130×130					

\* Engine oil capacity may differ from the above depending on an engine installed on a machine unit.

\*\* Engine mass and dimensions without radiator

## (9) 4TNV98

Engine name		Unit	4TNV98					
Engine specification class		-	CL			VM		
Type		-	Vertical, in-line, 4-cycle, water-cooled diesel engine					
Combustion chamber		-	Direct injection					
Number of cylinders		-	4					
Cylinder bore×stroke		mm×mm	98×110					
Displacement		L	3.318					
Continuous rating	Revolving speed	Min <sup>-1</sup>	1500	1800	-			
	Output	kW (hp)	30.9 (42.0)	36.8 (50.0)	-			
Rated output	Revolving speed	Min <sup>-1</sup>	1500	1800	2000	2200	2400	2500
	Output	kW (hp)	34.6 (47.0)	41.2 (56.0)	41.9 (57.0)	45.6 (62.0)	49.3 (67.0)	51.1 (69.5)
Max. no-load speed (±25)		min <sup>-1</sup>	1600	1895	2180	2400	2590	2700
Ignition order		-	1-3-4-2-1(No.1 cylinder on flywheel side)					
Power take off		-	Flywheel					
Direction of rotation		-	Counterclockwise (viewed from flywheel)					
Cooling system		-	Radiator					
Lubrication system		-	Forced lubrication with trochoid pump					
Starting system		-	Electric					
Applicable fuel		-	Diesel oil-ISO 8217 DMA, BS 2869 A1 or A2 (Cetane No.45 min.)					
Applicable lubricant		-	API grade class CD or CF					
Lubricant capacity (oil pan) *	Total	L	10.2					
	Effective	L	4.5					
Coolant water capacity (engine only)		L	4.2					
Engine dimensions ** (with flywheel housing)	Overall length	mm	719					
	Overall width	mm	498					
	Overall height	mm	717					
Engine mass (dry) ** (with flywheel housing)		kg	248 (equivalent to SAE#3)			235 (equivalent to SAE#4)		
Cooling fan (std.)		mm	410 mm O/D, 6 blades pusher type					
Crankshaft V pulley diameter & Fun V pulley diameter (std.)		mm	130×130					

\* Engine oil capacity may differ from the above depending on an engine installed on a machine unit.

\*\* Engine mass and dimensions without radiator

## (10) 4TNV98T

Engine name		Unit	4TNV98T						
Engine specification class		-	CL		VM				
Type		-	Vertical, in-line, 4-cycle, water-cooled diesel engine						
Combustion chamber		-	Direct injection						
Number of cylinders		-	4						
Cylinder borexstroke		mmxmm	88x110						
Displacement		L	3.318						
Continuous rating	Revolving speed	Min <sup>-1</sup>	1500	1800	-				
	Output	kW (hp)	37.9 (51.5)	45.6 (62.0)	-				
Rated output	Revolving speed	Min <sup>-1</sup>	1500	1800	2000	2200	2400	2500	2600
	Output	kW (hp)	41.9 (57.0)	50.4 (68.5)	50.7 (69.0)	55.5 (75.5)	60.3 (82.0)	62.5 (85.0)	64.0 (87.0)
Max. no-load speed (±25)		min <sup>-1</sup>	1600	1895	2180	2400	2590	2700	2810
Ignition order		-	1-3-4-2-1(No.1 cylinder on flywheel side)						
Power take off		-	Flywheel						
Direction of rotation		-	Counterclockwise (viewed from flywheel)						
Cooling system		-	Radiator						
Lubrication system		-	Forced lubrication with trochoid pump						
Starting system		-	Electric						
Applicable fuel		-	Diesel oil-ISO 8217 DMA, BS 2869 A1 or A2 (cetane No.45 min.)						
Applicable lubricant		-	API grade class CD or CF						
Lubricant capacity (oil pan) *	Total	L	10.2						
	Effective	L	4.5						
Coolant water capacity (engine only)		L	4.2						
Engine dimensions ** (with flywheel housing)	Overall length	mm	715						
	Overall width	mm	575						
	Overall height	mm	779						
Engine mass (dry) ** (with flywheel housing)		kg	258 (equivalent to SAE#3)		245 (equivalent to SAE#4)				
Cooling fan (std.)		mm	430 mm O/D, 8 blades suction type						
Crankshaft V pulley diameter & Fun V pulley diameter (std.)		mm	130x130						

\* Engine oil capacity may differ from the above depending on an engine installed on a machine unit.

\*\* Engine mass and dimensions without radiator

## (11) 4TNV106

Engine name		Unit	4TNV106					
Engine specification class		-	CL			VM		
Type		-	Vertical, in-line, 4-cycle, water-cooled diesel engine					
Combustion chamber		-	Direct injection					
Number of cylinders		-	4					
Cylinder bore×stroke		mm×mm	106×125					
Displacement		L	4.412					
Continuous rating	Revolving speed	Min <sup>-1</sup>	1500	1800	-			
	Output	kW (hp)	41.2 (56.0)	49.3 (67.0)	-			
Rated output	Revolving speed	Min <sup>-1</sup>	1500	1800	2000	2200	2400	2500
	Output	kW (hp)	45.6 (62.0)	54.4 (74.0)	56.6 (77.0)	61.4 (83.5)	65.5 (89.0)	67.7 (92.0)
Max. no-load speed (±25)		min <sup>-1</sup>	1600	1895	2180	2400	2590	2700
Ignition order		-	1-3-4-2-1(No.1 cylinder on flywheel side)					
Power take off		-	Flywheel					
Direction of rotation		-	Counterclockwise (viewed from flywheel)					
Cooling system		-	Radiator					
Lubrication system		-	Forced lubrication with trochoid pump					
Starting system		-	Electric					
Applicable fuel		-	Diesel oil-ISO 8217 DMA, BS 2869 A1 or A2 (Cetane No.45 min.)					
Applicable lubricant		-	API grade class CD or CF					
Lubricant capacity (oil pan) *	Total	L	14.0					
	Effective	L	9.0			7.5		
Coolant water capacity (engine only)		L	6.0					
Engine dimensions ** (with flywheel housing)	Overall length	mm	808			776		
	Overall width	mm	629			629		
	Overall height	mm	803			803		
Engine mass (dry) ** (with flywheel housing)		kg	345 (equivalent to SAE#3)			330 (equivalent to SAE#3)		
Cooling fan (std.)		mm	500 mm O/D, 7 blades pusher type			500 mm O/D, 7 blades suction type		
Crankshaft V pulley diameter & Fun V pulley diameter (std.)		mm	150×150					

\* Engine oil capacity may differ from the above depending on an engine installed on a machine unit.

\*\* Engine mass and dimensions without radiator

## (12) 4TNV106T

Engine name		Unit	4TNV106T			
Engine specification class		-	CL		VM	
Type		-	Vertical, in-line, 4-cycle, water-cooled diesel engine			
Combustion chamber		-	Direct injection			
Number of cylinders		-	4			
Cylinder bore×stroke		mm×mm	106×125			
Displacement		L	4.412			
Continuous rating	Revolving speed	Min <sup>-1</sup>	1500	1800	-	
	Output	kW (hp)	51.5 (70.0)	61.8 (84.0)	-	
Rated output	Revolving speed	Min <sup>-1</sup>	1500	1800	2000	2200
	Output	kW (hp)	56.8 (77.2)	68.0 (92.5)	69.9 (95.0)	72.0 (97.9)
Max. no-load speed (±25)		min <sup>-1</sup>	1600	1895	2180	2400
Ignition order		-	1-3-4-2-1(No.1 cylinder on flywheel side)			
Power take off		-	Flywheel			
Direction of rotation		-	Counterclockwise (viewed from flywheel)			
Cooling system		-	Radiator			
Lubrication system		-	Forced lubrication with trochoid pump			
Starting system		-	Electric			
Applicable fuel		-	Diesel oil-ISO 8217 DMA, BS 2869 A1 or A2 (Cetane No.45 min.)			
Applicable lubricant		-	API grade class CD or CF			
Lubricant capacity (oil pan) *	Total	L	14.0			
	Effective	L	9.0		7.5	
Coolant water capacity (engine only)		L	6.0			
Engine dimensions ** (with flywheel housing)	Overall length	mm	808		776	
	Overall width	mm	629		628.6	
	Overall height	mm	866		866	
Engine mass (dry) ** (with flywheel housing)		kg	355 (equivalent to SAE#3)		340 (equivalent to SAE#3)	
Cooling fan (std.)		mm	500 mm O/D, 7 blades pusher type		500 mm O/D, 7 blades suction type	
Crankshaft V pulley diameter & Fun V pulley diameter (std.)		mm	150×150			

\* Engine oil capacity may differ from the above depending on an engine installed on a machine unit.

\*\* Engine mass and dimensions without radiator



## 1.3 Fuel Oil, Lubricating Oil and Coolant Water

### 1.3.1 Fuel oil

**IMPORTANT:**

Only use the recommended fuel to obtain the best engine performance and prevent damage of parts, also prevent air pollution.

#### (1) Selection of fuel oil

Use the following diesel fuels for best engine performance:

BS 2869 A1 or A2

Fuels equivalent to Japanese Industrial Standard, JIS. No. K2204-2

Fuel cetane number should be 45 or greater

#### (2) Fuel handling

- Water and dust in the fuel oil can cause operation failure. Use containers which are clean inside to store fuel oil. Store the containers away from rain water and dust.
- Before supplying fuel, let the fuel container rest for several hours so that water and dust in the fuel are deposited on the bottom. Pump up only the clean fuel.

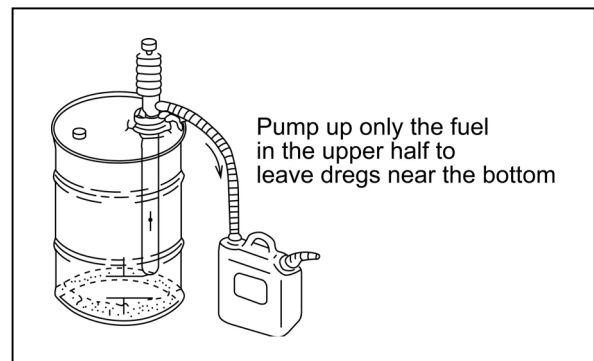

#### (3) Fuel tank

Be sure to attach a drain cock, precipitation trap and primary strainer to the fuel tank as shown illustration right.

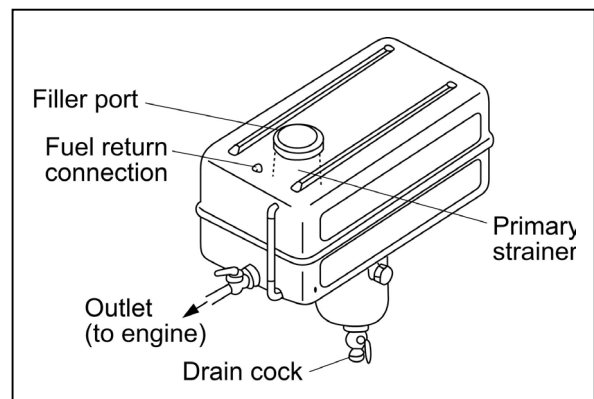

### 1.3.2 Lubricating oil

#### IMPORTANT:

Use of other than the specified engine oil may cause inner parts seizure or early wear, leading to shorten the engine service life.

#### (1) Selection of engine lube oil

Use the following engine oil

- API classification ..... CD or CF  
(Standards of America Petroleum Institute)
- SAE viscosity ..... 10W-30 or 15W-40  
(Standard of Society of Automotive Engineering)

Engine oil with 10W30 or 15W40 can be used throughout the year.

(Refer to the right figure.)

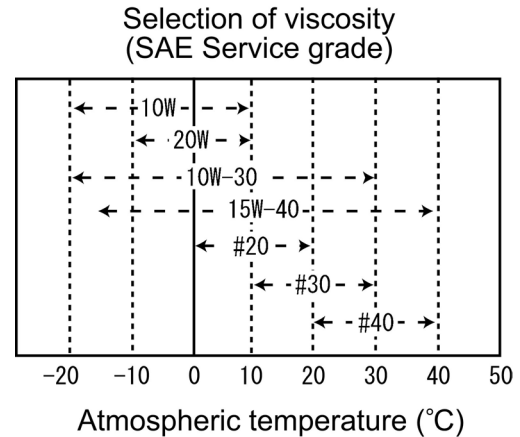

15W-40/10W-30 can be used almost throughout the year.

#### (2) Handling of engine oil

- Carefully store and handle the oil so as to prevent dust or dirt entrance. When supplying the oil, pay attention and clean around the filler port.
- Do not mix different types of oil as it may adversely affect the lubricating performance.



When touching engine oil by hand, the skin of the hand may become rough. Be careful not to touch oil with your hands without protective gloves. If touch, wash your hands with soap and water thoroughly.

### 1.3.3 Coolant water

Use clean soft water and be sure to add the Long Life Coolant Antifreeze (LLC) in order to prevent rust built up and freezing. If there is any doubt over the water quality, distilled water or pre-mixed coolant should be used.

The coolants / antifreezes, which are good performance for example, are shown below.

- TEXACO LONG LIFE COOLANT ANTIFREEZE, both standard and pre-mixed.  
Product codes 7997 and 7998
- HAVOLINE EXTENDED LIFE ANTIFREEZE / COOLANT  
Product code 7994

#### IMPORTANT:

- Be sure to add Long Life Coolant Antifreeze(LLC) to soft water. In cold season, the LLC is especially important. Without LLC, cooling performance will decrease due to scale and rust in the coolant water line. Without LLC, coolant water will freeze and expand to break the cooling line.
- Be sure to use the mixing ratios specified by the LLC manufacturer for your temperature range.
- Do not mix different types (brand) of LLC, chemical reactions may make the LLC useless and engine trouble could result.
- Replace the coolant water every once a year.



When handling Long Life Coolant Antifreeze, wear protective rubber gloves not to touch it. If LLC gets eyes or skin, wash with clean water at once.

## 1.4 Engine External Views

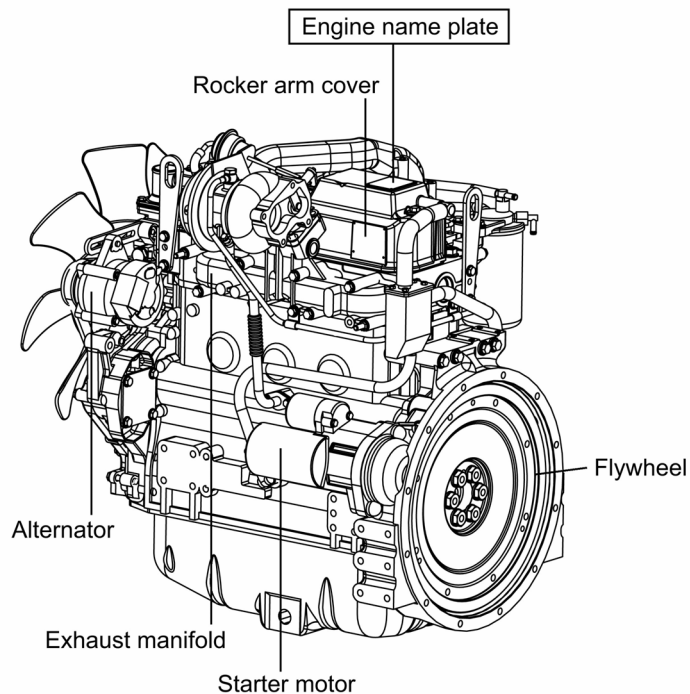
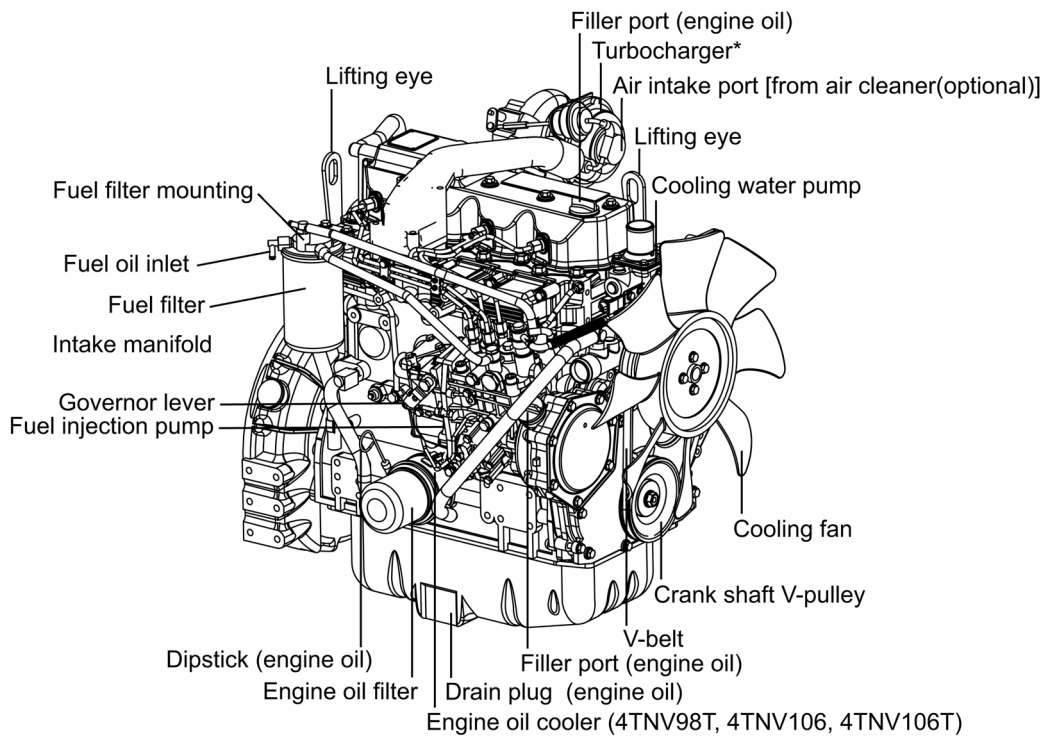

- Note) • This illustration shows the 4TNV98T engine (with turbocharger).  
 • The drain plug (engine oil) location depends on the engine installed on the machine unit to be on the fuel injection pump side (above illustration) or starter motor side.

## 1.5 Structural Description

### 2-valve cylinder head

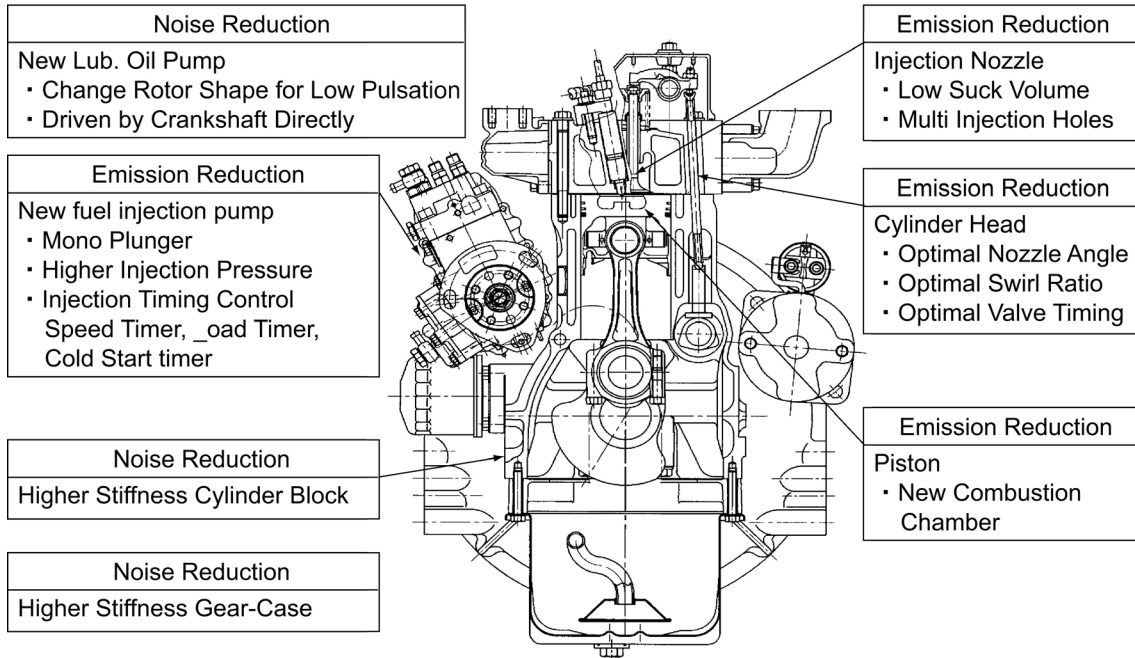

### 4-valve cylinder head

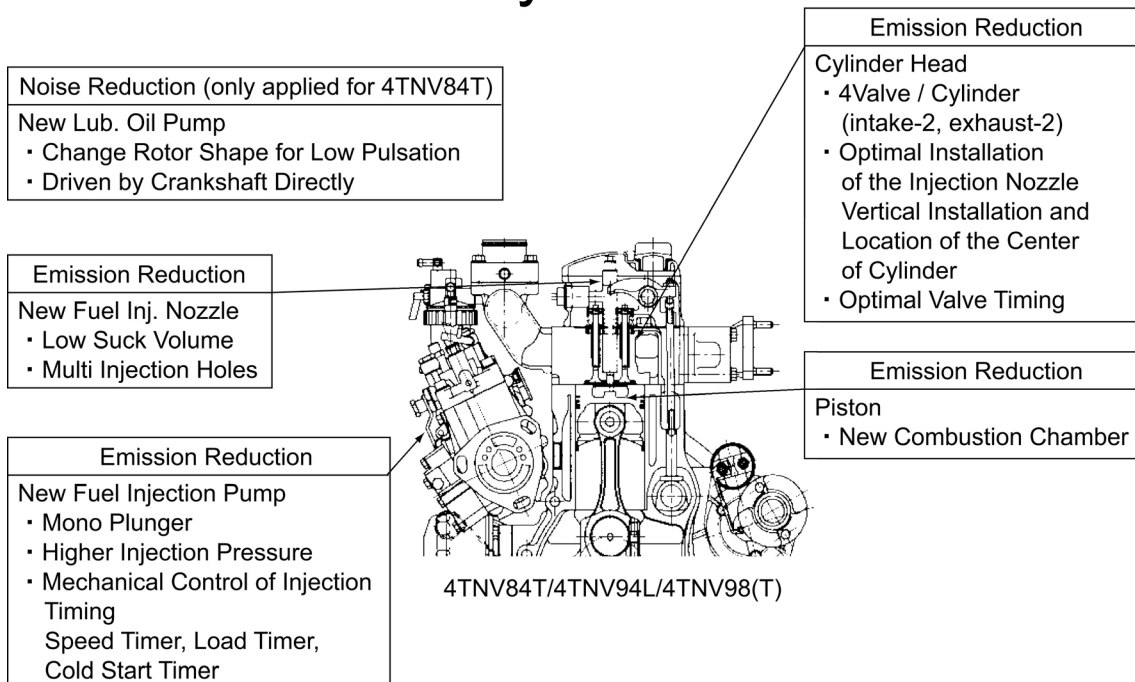

## 1.6 Exhaust gas emission regulation

The engines in this manual have been certified by the US EPA, California ARB and/or the 97/68/EC Directive.

### California

#### Proposition 65 Warning

Diesel engine exhaust and some of its constituents are known to the State of California to cause cancer, birth defects, and other reproductive harm.

### California

#### Proposition 65 Warning

Battery posts, terminals, and related accessories contain lead and lead compounds, chemicals known to the State of California to cause cancer and reproductive harm.

### 1.6.1 The Emission Standard in USA

#### (1) EPA Nonroad Diesel Engine Emission Standards

g/kW-hr(g/bhp-hr)							
Engine Power	Tier	Model Year	NOx	HC	NMHC+NOx	CO	PM
kW < 8 (hp < 11)	Tier 1	2000	-	-	10.5 (7.8)	8.0 (6.0)	1.0 (0.75)
	Tier 2	2005	-	-	7.5 (5.6)	8.0 (6.0)	0.80 (0.60)
8 ≤ kW < 19 (11 ≤ hp < 25)	Tier 1	2000	-	-	9.5 (7.1)	6.6 (4.9)	0.80 (0.60)
	Tier 2	2005	-	-	7.5 (5.6)	6.6 (4.9)	0.80 (0.60)
19 ≤ kW < 37 (25 ≤ hp < 50)	Tier 1	1999	-	-	9.5 (7.1)	5.5 (4.1)	0.80 (0.60)
	Tier 2	2004	-	-	7.5 (5.6)	5.5 (4.1)	0.60 (0.45)
37 ≤ kW < 75 (50 ≤ hp < 100)	Tier 1	1998	9.2 (6.9)	-	-	-	-
	Tier 2	2004	-	-	7.5 (5.6)	5.0 (3.7)	0.40 (0.30)
	Tier 3	2008	-	-	4.7 (3.5)	5.0 (3.7)	
75 ≤ kW < 130 (100 ≤ hp < 175)	Tier 1	1997	9.2 (6.9)	-	-	-	-
	Tier 2	2003	-	-	6.6 (4.9)	5.0 (3.7)	0.30 (0.22)
	Tier 3	2007	-	-	4.0 (3.0)	5.0 (3.7)	

Note1) The EPA emission regulation under 130kW is mentioned below.

Note2) As for Model year, the year which a regulation is applicable to is shown.

Engine classification	Transient smoke standards % opacity (acceleration/lug/peak modes)
Constant speed engine	Not regulated
Variable speed engine	20/15/50 or less

#### (2) California ARB Emission Regulation

The ARB emission standard is based on that of the EPA.

## 1.6.2 Engine identification

### (1) Emission control labels of US EPA

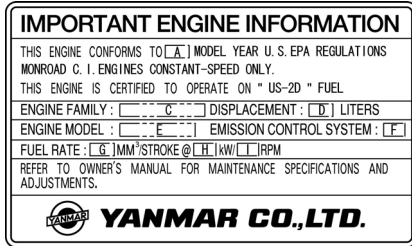

EPA label for constant speed engines

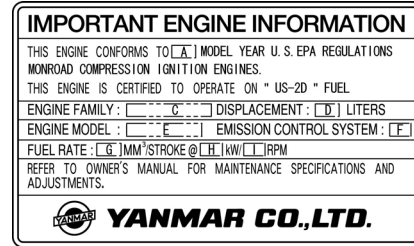

EPA label for variable speed engines

### (2) Emission control label for both EPA and ARB

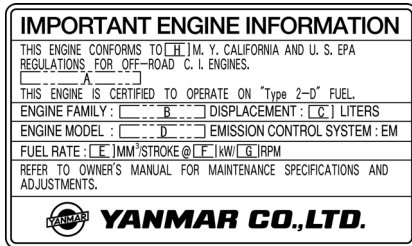

### (3) 97/68EC Directive label

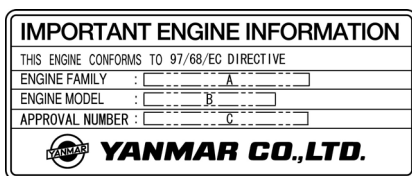

### 1.6.3 Guarantee Conditions for the EPA Emission Standard

The following guarantee conditions are set down in the operation manual. In addition to making sure that these conditions are met, check for any deterioration that may occur before the required periodic maintenance times.

(1) Requirement on engine installation condition

(a) Intake air depression

kPa(mmAq)	
Initial	Permissible
≤ 2.9(300)	≤ 6.23 (635)

(b) Exhaust gas back pressure

kPa (mmAq)		
Engine type	Initial	Permissible
Naturally aspirated engines	≤ 12.7(1300)	≤ 15.3(1560)
4TNV98T, 4TNV106T	≤ 9.8(1000)	≤ 11.7(1200)
3,4TNV84T	≤ 4.9(500)	≤ 5.9(600)

(2) Fuel oil and lubricating oil

(a) Fuel: The diesel fuel oil US No.2 diesel fuel oil.

(b) Lube oil: API grade, class CD or CF

(3) Do not remove the seals restricting injection quantity and engine speed.

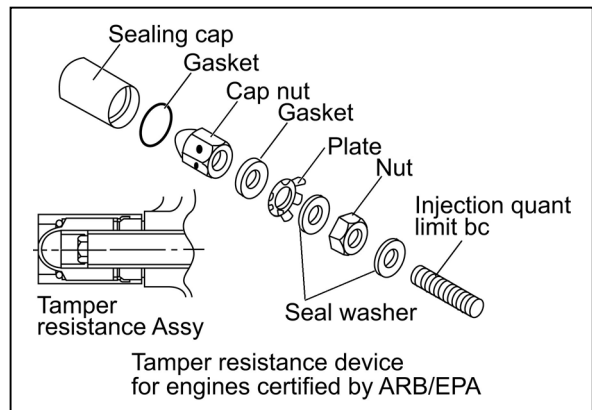

**(4) Perform maintenance without fail.**

Note: Inspections to be carried out by the user and by the maker are divided and set down in the “List of Periodic Inspections” and should be checked carefully.

**(5) Maintenance period and Quality guarantee period for exhaust emission related parts**

The maintenance of the parts related to the exhaust emission must be carried out in the maintenance period as shown in the below table.

A guarantee period is that either the operation hours or years shown in the table come first in the condition that the maintenance inspection was carried out based on the “List of Periodic Inspections”.

Parts Power Rating	Maintenance period		Quality Guarantee Period
		● Fuel nozzle cleaning	Adjustment, cleaning, repairs for fuel nozzle, fuel pump, turbocharger, electronic control unit etc.
37 ≤ kW < 130	Every 1500 hours (applied from Tier 2)	Every 3000 hours (applied from Tier 2)	3000 hours / 5 years
19 ≤ kW < 37 except constant speed engines ≥ 3000min <sup>-1</sup>	Every 1500 hours	Every 3000 hours	3000 hours / 5 years
KW < 19 And constant speed engines beyond 3000min <sup>-1</sup> under 37kW	Every 1500 hours	Every 3000 hours	1500 hours / 2 years



## 2. Inspection and Adjustment

### 2.1 Periodic Maintenance Schedule

The engine periodic inspection timing is hard to determine as it varies with the application, load status, qualities of the fuel and lubricating oils used and handling status. General rules are described here.

○: User-maintenance ◎: Parts replacement ●: Shop-inspection

Classification	Item	Daily	Maintenance period				
			Every 50 hours	Every 250 hours or 3 months	Every 500 hours or 6 months	Every 1000 hours or one year	Every 2000 hours or two years
Whole	Visual check around engine	○					
Fuel oil system	Fuel tank level check and fuel supply	○					
	Fuel tank draining		○				
	Water separator (Option) draining		○				
	Bleeding the fuel system		○				
	Water separator cleaning				○		
	Fuel filter element replacement				◎		
Lubricating oil system	Lube oil level check and replenishment	○					
	Lube oil replacement						
	Lube oil filter replacement		◎ 1 <sup>st</sup> time	◎ 2 <sup>nd</sup> time and thereafter			
Cooling water system	Coolant water level check and replenishment	○					
	Radiator fin cleaning			○			
	V-belt tension check		○ 1 <sup>st</sup> time	○ 2 <sup>nd</sup> time and thereafter			
	Coolant water replacement				◎		
	Coolant/water path flushing and maintenance						●
Rubber house	Fuel pipe and coolant water pipe inspection and maintenance	○					●
Governor	Inspection and adjustment of governor lever and accelerator	○		○			
Air intake system	Air cleaner cleaning and element replacement			○	◎		
	Diaphragm assy inspection					● (2 years)	
	Turbocharger blower cleaning*					●*	
Electrical system	Warning lamp & instruments function check	○					
	Battery electrolyte level check and battery recharging		○				
Cylinder head	Intake/exhaust valve head clearance adjustment					●	
	Intake/exhaust valve seat lapping						●
Fuel injection pump and nozzle	Fuel injection nozzle pressure inspection					●*	
	Fuel injection timing adjustment Fuel injection pump inspection and adjustment						●*

\*) EPA allows to maintain the emission related parts every 1,500 or 3,000 hours as shown in 1.6.3 of chapter1.

## 2.2 Periodic Inspection and Maintenance Procedure

### 2.2.1 Check before Daily Operation

Be sure to check the following points before starting an engine every day.

No.	Inspection Item
(1)	Visual check around engine
(2)	Fuel tank level check and fuel supply
(3)	Lube oil level check and replenishment
(4)	Coolant water level check and replenishment
(5)	Fuel pipe and coolant water pipe inspection and maintenance
(6)	Inspection and adjustment of governor lever and accelerator
(7)	Warning lamp & instruments function check

#### (1) Visual check around engine

If any problem is found, do not use before the engine repairs have been completed.

- Oil leak from the lubrication system
- Fuel leak from the fuel system
- Coolant water leak from the cooling water system
- Damaged parts
- Loosened or lost bolts
- Fuel, radiator rubber hoses, V belt cracked, loosened clamp

#### (2) Fuel tank level check and fuel supply

Check the remaining fuel oil level in the fuel tank and refuel the recommended fuel if necessary. (Refer to 1.3.(1) )

#### (3) Lube oil level check and replenishment

##### (a) Checking oil level

Check the lube oil level with the dipstick, after adjusting the posture of the machine unit so that an engine may become a horizontality. Insert the dipstick fully and check the oil level. The oil shall not be contaminated heavily and have appropriate viscosity. No coolant water or diesel fuel shall be mixed. When lube oil is supplied after the engine running, check the lube oil level after about 10 minutes pass after the engine shutdown so that the lube oil inside may be returned the oil pan.

##### Standard

The level shall be between the upper and lower limit lines on the dipstick.

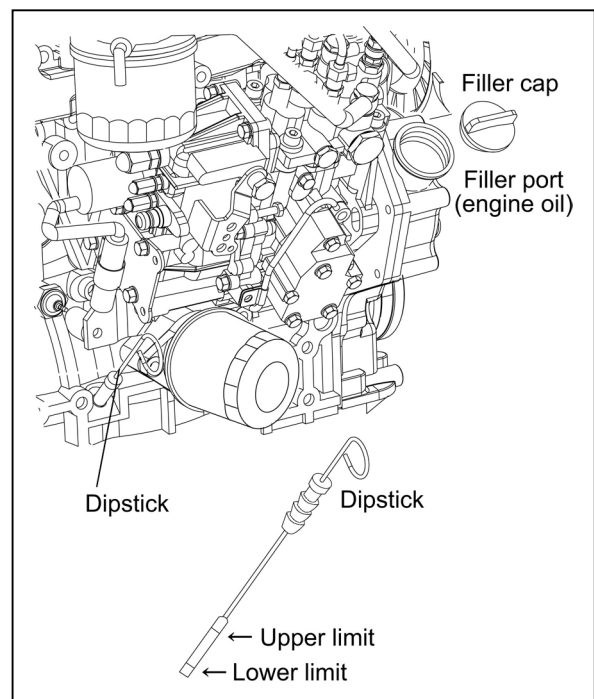

(Unit: liter)

Model	Total volume (L)	Effective volume (L)
3TNV82A	5.5	1.9
3TNV84(T)·88	6.7	2.8
4TNV84(T)·88	7.4	3.4
4TNV94L·98(T)	10.5	4.5
4TNV106(T) (CL class)	14.0	9.0
4TNV106(T) (VM class)	14.0	7.5

Lube oil capacity may differ from the above volume depending on an engine installed on a machine unit.

(b) Replenishing oil pan with lube oil

If the remaining engine oil level is low, fill the oil pan with the specified engine oil to the specified level through the filler port.

[NOTICE]

The oil should not be overfilled to exceed the upper limit line. Otherwise a naturally-aspirated engine may intake lube oil in the combustion chamber during the operation, then white smoke, oil hummer or urgent rotation may occur, because the blowby gas is reduced in the suction air flow. In case of turbo-charged engine oil may jet out from the breather or the engine may become faulty.

(4) Coolant water Inspection

Daily inspection of coolant water should be done only by Coolant recovery tank.



- Never open the radiator filler cap while the engine and radiator are still hot. Steam and hot water will spurt out and seriously burn you. Wait until the radiator is cooled down after the engine has stopped, wrap the filler cap with a rag piece and turn the cap slowly to gently release the pressure inside the radiator.
- Securely tighten the filler cap after checking the radiator. Steam can spurt out during operation, if the cap is tightened loosely.

(a) Checking coolant water volume

Check the coolant water level in the Coolant recovery tank. If the water level is close to the LOW mark, open the Coolant recovery tank cap and replenish the Coolant recovery tank with clean soft water to the FULL mark.

**Standard**

The water level of the Coolant recovery tank shall be between the upper and lower limit lines.

(b) Replenishing engine with water

If the Coolant recovery tank water level is lower than the LOW mark, open the radiator cap and check the coolant water level in the radiator. Replenish the radiator with the coolant water, if the level is low.

- Check the coolant water level while the engine is cool. Checking when the engine is hot is dangerous. And the water volume is expanded due to the heat.
- Daily coolant water level check and replenishing shall be done only at the Coolant recovery tank. Usually do not open the radiator cap to check or replenish.

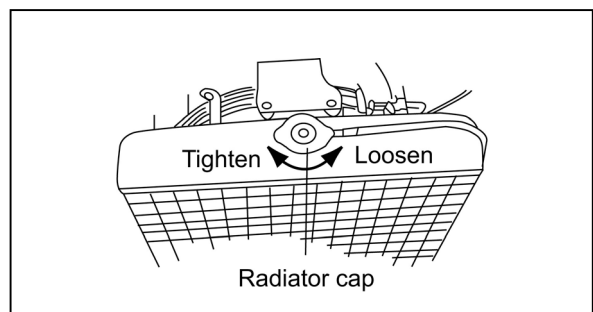

**IMPORTANT:**

If the coolant water runs short quickly or when the radiator runs short of water with the Coolant recovery tank level unchanged, water may be leaking or the air tightness may be lost. Increase in the Coolant recovery tank water level during operation is not abnormal.

The increased water in the Coolant recovery tank returns to the radiator when the engine is cooled down.

If the water level is normal in the Coolant recovery tank but low in the radiator, check loosened clamping of the rubber hose between the radiator and Coolant recovery tank or tear in the hose.

**Standard**

Engine: The radiator shall be filled up.

(Unit: liter)

Model	Coolant water volume In an engine
3TNV82A	1.8
3TNV84(T) 3TNV88	2.0
4TNV84(T) 4TNV88	2.7
4TNV94L 4TNV98(T)	4.2
4TNV106(T)	6.0

Engine coolant water capacity may differ from the above volume depending on an engine installed on a machine unit.

**(5) Fuel pipe and coolant water pipe inspection and maintenance**

Check the rubber hoses for fuel and coolant water pipes cracked. If the cracked hose is found, replace it with new one. Check the loosened clamp. If found, tighten it.

**(6) Inspection and adjustment of governor lever and accelerator**

Make sure the accelerator of the machine unit can be operated smoothly before starting the engine. If it feels heavy to manipulate, lubricate the accelerator cable joints and pivots. Adjust the accelerator cable if there is a dislocation or excessive play between the accelerator and the governor lever. Refer to 3.2.3.

**(7) Warning lamp & instruments function check**

Before and after starting the engine, check to see that the alarm function normally. Failure of alarm cannot warn the lack of the engine oil or the coolant water. Make it a rule to check the alarm operation before and after starting engine every day. Refer to each manual for machine units in details.

**2.2.2 inspection after initial 50 hours operation**

Be sure to check the following points after initial 50 hours operation, thereafter every 250 hours or 3 months operation.

No.	Inspection Item
(1)	Lube oil and filter replacement
(2)	V-belt tension check

**(1) Lube oil and filter replacement (1st time)**

When an engine is still hot, be careful with a splash of engine oil which may cause burns. Replace engine oil after the engine oil becomes warm. It is most effective to drain the engine oil while the engine is still warm.

In early period of use, the engine oil gets dirty rapidly because of the initial wear of internal parts. Replace the engine oil earlier.

Lube oil filter should also be replaced when the engine oil is replaced.

The procedure of lube oil and lube oil filter replacement is as follows.

(a) Drain engine oil

- Prepare a waste oil container collecting waste oil.
- Remove the oil filler cap to drain easily while draining the lube oil.
- Loosen the drain plug using a wrench (customer procured) to drain the lube oil.
- Securely tighten the drain plug after draining the lube oil.

[NOTICE]

Use a socket wrench or a closed wrench when removing or tightening a drain plug.

Don't use a spanner because it has the possibility that the spanner will slip and it will get hurt.

(b) Replacing oil filter

- Turn the lube oil filter counter-clockwise using a filter wrench (customer procured) to remove it.
- Clean the mounting face of the oil filter.
- Moisten the new oil filter gasket with the engine oil and install the new engine oil filter manually turning it clockwise until it comes into contact with the mounting surface, and tighten it further to 3/4 of a turn with the filter wrench.

Tightening torque: 20~24N·m (2.0~2.4kgf·m)

Model	Applicable oil filter Part No.
3TNV82A~4TNV98(T)	129150-35151
4TNV106(T)	119005-35100

(c) Filling oil and inspection

- Fill with new engine oil until it reaches the specified level.

IMPORTANT:

Do not overfill the oil pan with engine oil.

Be sure to keep the specified level between upper and lower limit on the dipstick.

- Warm up the engine by running for 5 minutes while checking any oil leakage
- Stop the engine after warming up and leave it stopping for about 10 minute to recheck the engine oil level with dipstick and replenish the engine oil. If any oil is spilled, wipe it away with a clean cloth.

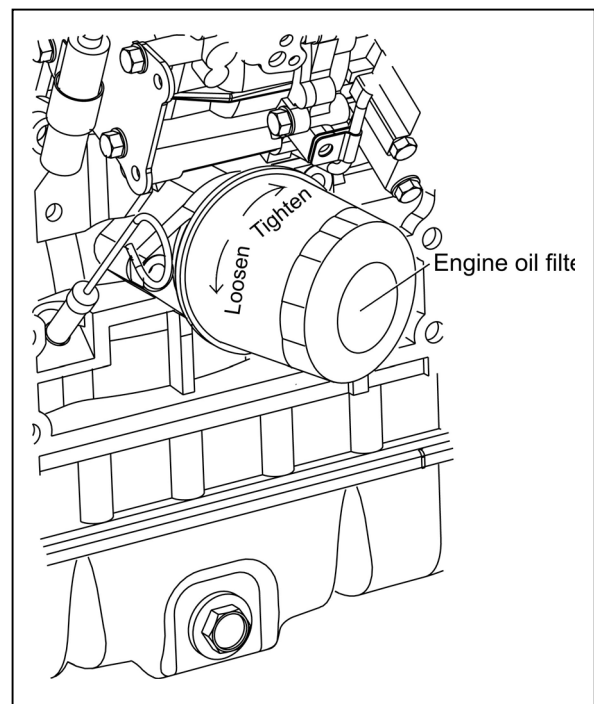
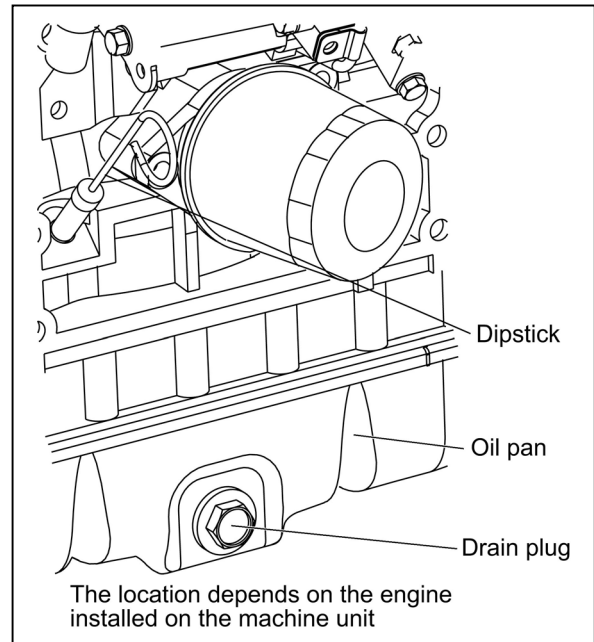

(2) V-belt tension check

When there is not enough tension in the V-belt, the V-belt will slip making it impossible for the alternator to generate power and cooling water pump and cooling fan will not work causing the engine to overheat.

Check and adjust the V-belt tension (deflection) in the following manner.

[NOTICE]

Be especially careful not to splash engine oil on the V-belt, because it will cause slipping, stretching and aging of the belt.

- 1) Press the V-belt with your thumb [approx. 98N(10kgf)] at the middle of the V-belt span to check the tension (deflection).  
Available positions to check and adjust the V-belt tension (deflection) are at the A, B or C direction as shown in the illustration right.  
You may choose a position whichever you can easily carry out the check and adjustment on the machine unit.

- "New V-belt" refers to a V-belt, which has been used less than 5 minutes on a running engine.
- "Used V-belt" refers to a V-belt, which has been used on a running engine for 5 minutes or more.

The specified deflection to be measured at each position should be as follows.

(Unit: mm)

Direction	A	B	C
For used V-belt	10~14	7~10	9~13
For new V-belt	8~12	5~8	7~11

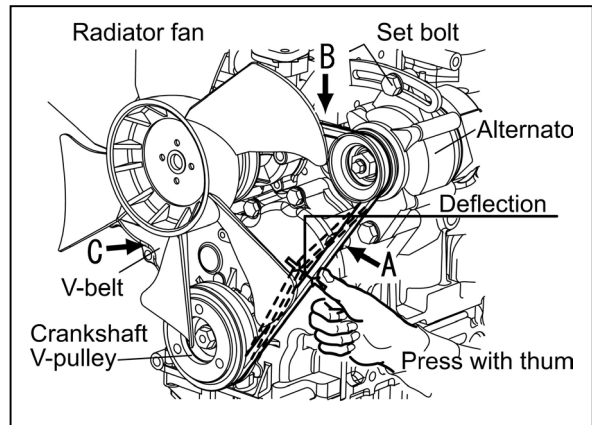

- 2) If necessary, adjust the V-belt tension (deflection).

To adjust the V-belt tension, loosen the set bolt and move the alternator to tighten the V-belt. After replacing with a new V-belt and adjusting it, run the engine for 5 minutes and readjust the deflection to the value in the table above.

- 3) After replacing with a new V-belt and adjusting it, run the engine for 5 minutes and readjust the deflection to the value in the table above.

- 4) Visually check the V-belt for cracks, oiliness or wear. If any, replace the V-belt with new one.

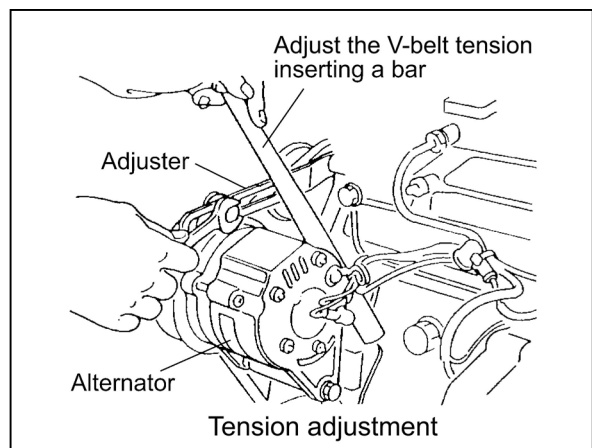

### 2.2.3 Inspection every 50 hours

Be sure to check the following points every 50 hours operation.

No.	Inspection Item
(1)	Fuel tank draining
(2)	Water separator draining
(3)	Bleeding the fuel system
(4)	Battery electrolyte level check and battery recharging

#### (1) Fuel tank draining

- 1) Prepare a waste oil container.
- 2) Remove the drain plug of the fuel tank to drain (water, dust, etc.) from the fuel tank bottom.
- 3) Drain until fuel with no water and dust flow out. Then tighten the drain plug firmly.

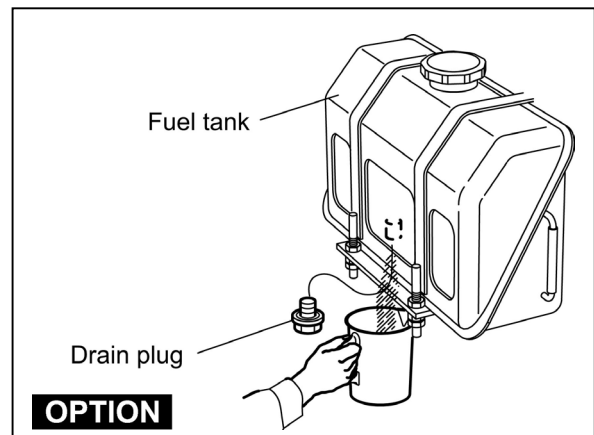

#### (2) Water separator draining

Drain off the water separator whenever there is a lot of drain collected in the water separator at the bottom of the cup even if not the time for periodic inspection hour. The cup of the water separator is made from semi-transparency material and in the cup, the red colored float ring which rises on the surface of the drain is installed to visualize the amount of drain. Also, the water separator with sensor to detect the drain for warning device on a control panel is provided as the optional.

Drain off the water separator in the following manner.

- 1) Prepare a waste oil container.
- 2) Close the fuel cock.
- 3) Loosen the drain cock at the bottom of the water separator, and drain off any water collected inside.
- 4) Tighten the drain cock with hand.
- 5) Be sure to bleed air in the fuel system.

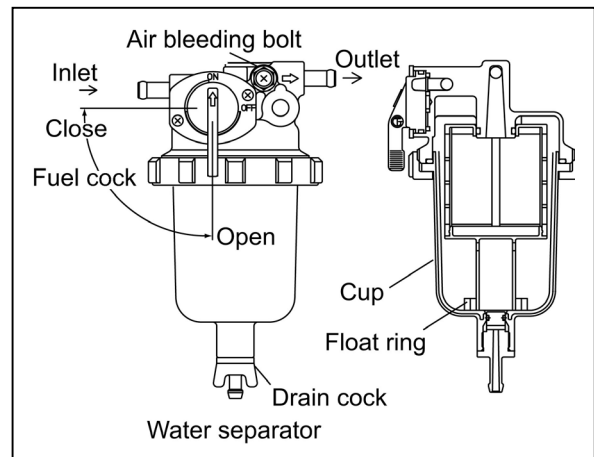

#### NOTE:

If no drain drips when the drain cock is opened, loosen the air bleeding bolt on the top of the water separator by turning counter-clockwise 2~3 times using screw driver.

(This may occur in case of the water separator position is higher than the fuel oil level in the fuel tank). After draining, be sure to tighten the air bleeding bolt.

### (3) Bleeding the fuel system

Bleed the fuel system according to the following procedures. When there is air in the fuel system, the fuel injection pump will not be able to function.

- 1) Check the fuel oil level in the fuel tank. Refuel if insufficient.
  - 2) Open the cock of the water separator.
  - 3) Loosen the air bleeding bolt on the water separator by turning 2~3 times to the counter-clockwise using screw driver or spanner.
  - 4) When the fuel coming out is clear and not mixed with any bubble, tighten the air bleeding bolt.
  - 5) Feed the fuel with the fuel priming pump or electro-magnetic fuel feed pump.
- In case of the engine using the electro-magnetic fuel feed pump.  
Turn the starter switch to the ON position and hold it in the position for 10~15 seconds to operate the fuel feed pump.
  - In case of the engine installed the fuel filter mounting with the fuel priming pump.  
The priming pump is on the top of the fuel filter mounting. Move the priming pump up and down to feed fuel until feel your hand slightly heavy.

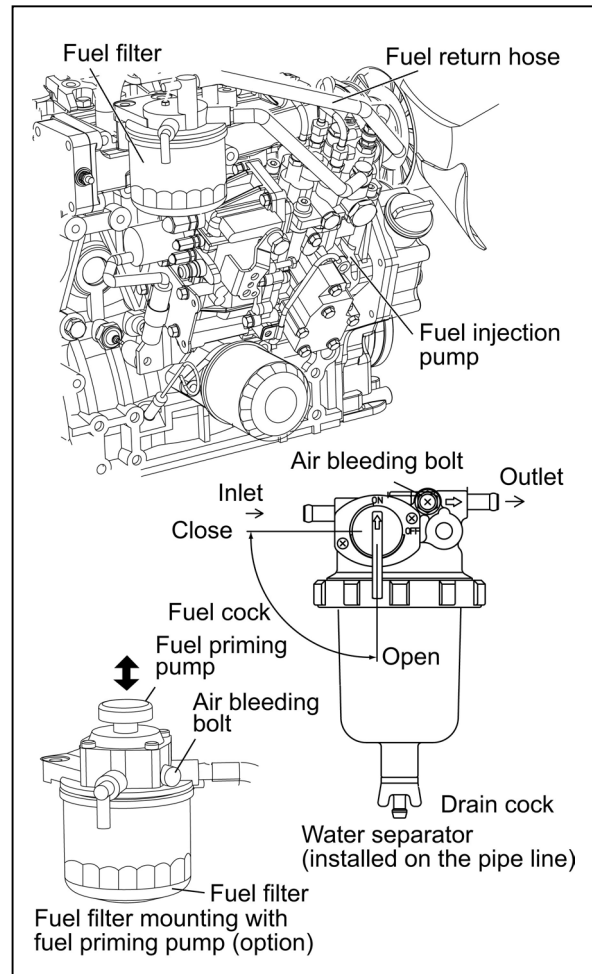

### (4) Battery electrolyte level check and battery recharging

#### **⚠ WARNING**



#### Fire due to electric short-circuit

- Make sure to turn off the battery switch or disconnect the negative cable (-) before inspecting the electrical system. Failure to do so could cause short-circuiting and fires.
- Always disconnect the (-) Negative battery cable first before disconnecting the battery cables from battery. An accidental "Short circuit" may cause damage, fire and or personal injury. And remember to connect the (-) Negative battery cable (back onto the battery) LAST.



#### Proper ventilation of the battery area

Keep the area around the battery well ventilated, paying attention to keep away any fire source. During operation or charging, hydrogen gas is generated from the battery and can be easily ignited.



#### Do not come in contact with battery electrolyte

Pay sufficient attention to avoid your eyes or skin from being in contact with the fluid. The battery electrolyte is dilute sulfuric acid and causes burns. Wash it off immediately with a large amount of fresh water if you get any on you.



**Battery structure**

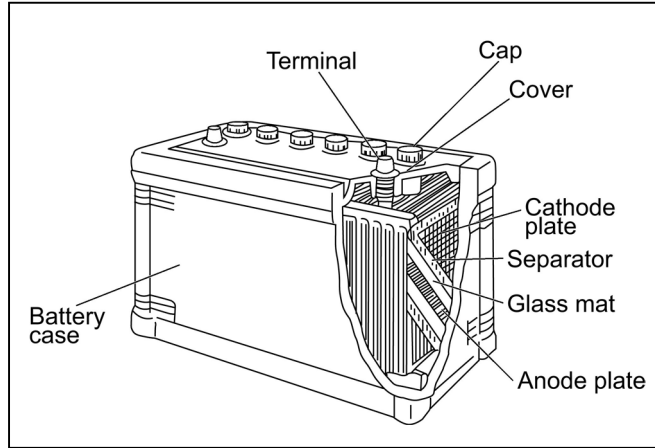

**(1) Electrolyte level**

- Check the level of fluid in the battery. When the amount of fluid nears the lower limit, fill with battery fluid (available in the market) to the upper limit. If operation continues with insufficient battery fluid, the battery life is shortened, and the battery may overheat and explode.
- Battery fluid tends to evaporate more quickly in the summer, and the fluid level should be checked earlier than the specified times.
- If the engine cranking speed is so slow that the engine does not start up, recharge the battery.
- If the engine still will not start after charging, replace the battery.
- Remove the battery from the battery mounting of the machine unit after daily use if letting the machine unit leave in the place that the ambient temperature could drop at  $-15^{\circ}\text{C}$  or less. And store the battery in a warm place until the next use the unit to start the engine easily at low ambient temperature.

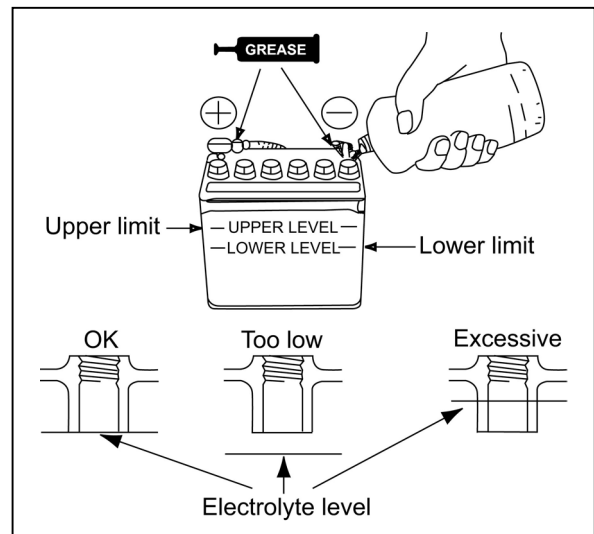

**(2) Battery charge**

Use a battery tester or hydrometer and check the battery condition. If the battery is discharged, recharge it.

**(a) Measurement with a battery tester**

When checking the battery with the batter tester, connect the red clip of the tester to the battery positive (+) terminal and black clip to the battery negative (-) terminal by pinching them securely, and judge the battery charge level from the indicator position.

Green zone: Normal

Yellow zone: Slightly discharged

Red zone: Defective or much discharged

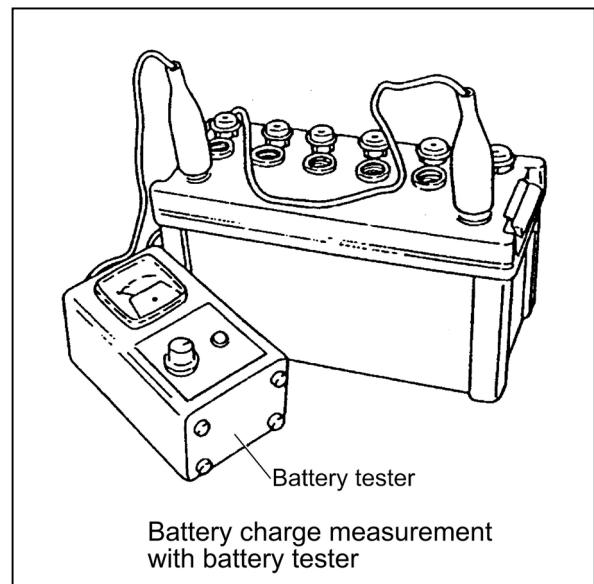

(b) Measurement with hydrometer

When using a hydrometer, the measured specific gravity must be corrected according to the temperature at the time of measurement. The specific gravity of battery electrolyte is defined with 20°C as the standard. Since the specific gravity increases or decreases by 0.0007 when the temperature varies by 1°C, correct the value according to the equation below.

$$S_{20} = S_t + 0.0007(t-20)$$

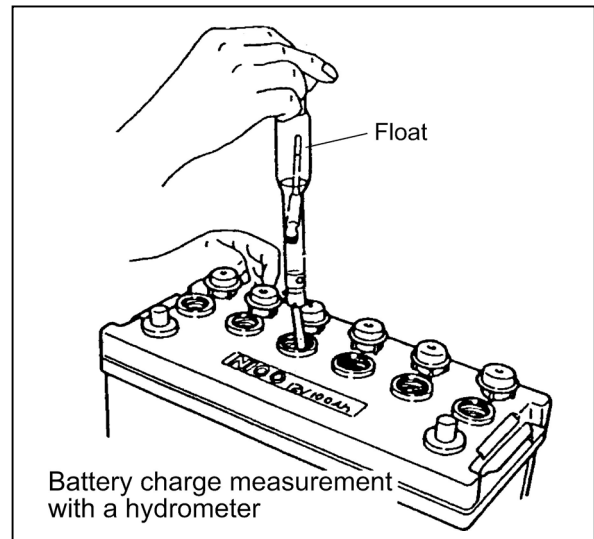
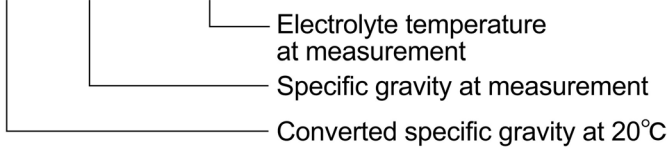

(c) Specific gravity and remaining battery charge

Specific gravity (20°C)	Discharged quantity of electricity (%)	Remaining charge (%)
1.28	0	100
1.26	10	90
1.24	20	80
1.23	25	75

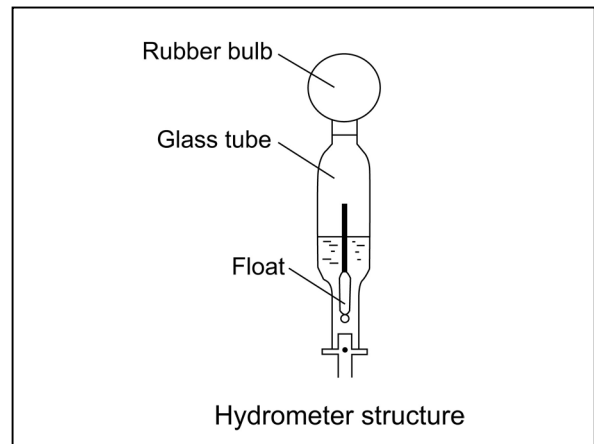

(3) Terminals

Clean if corroded or soiled.

(4) Mounting bracket

Repair or replace it if corroded.  
Retighten if loosened.

(5) Battery appearance

Replace the battery if cracked or deformed.  
Clean with fresh water if contaminated.

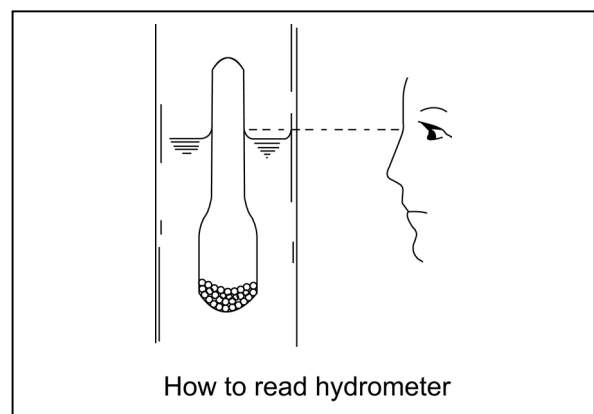

### 2.2.4 Inspection every 250 hours or 3 months

Be sure to check the following points every 250 hours or 3 months operation, whichever comes first.

No.	Inspection Item
(1)	Lube oil and filter replacement
(2)	Radiator fin cleaning
(3)	V-belt tension check
(4)	Inspection and adjustment of governor lever and accelerator
(5)	Air cleaner cleaning and element replacement

#### (1) Lube oil and filter replacement (The second replacement and after)

Replace the engine oil every 250 hours operation from 2nd time and on. Replace the engine oil filter at the same time. Refer to 2.2.1.(1).

#### (2) Radiator fin cleaning



#### Beware of dirt from air blowing

Wear protective equipment such as goggles to protect your eyes when blowing compressed air. Dust or flying debris can hurt eyes.

Dirt and dust adhering on the radiator fins reduce the cooling performance, causing overheating. Make it a rule to check the radiator fins daily and clean as needed.

- Blow off dirt and dust from fins and periphery with compressed air [0.19MPa (2kgf/cm<sup>2</sup>) or less] not to damage the fins with compressed air.
- If contaminated heavily, apply detergent, thoroughly clean and rinse with tap water shower.

#### IMPORTANT:

Never use high pressure water or air from close by fins or never attempt to clean using a wire brush. Radiator fins can be damaged.

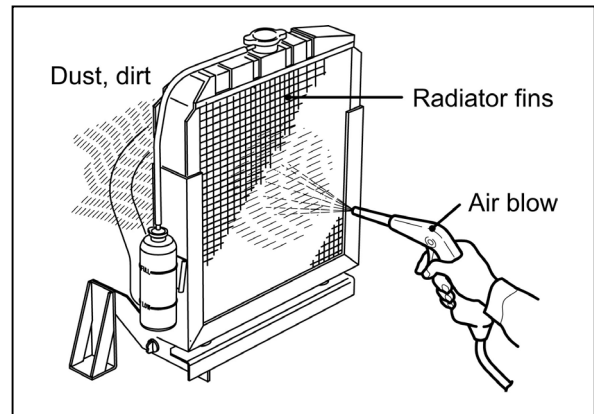

#### (3) V-belt tension check (The second time and after)

Check and adjust the V-belt tension. Refer to 2.2.2(2)

#### (4) Inspection and adjustment of governor lever and accelerator

The governor lever and accelerating devices (accelerating lever, pedal, etc.) of the machine unit are connected by an accelerating wire or rod. If the wire becomes stretched or the connections loose, the deviation in the position may result and make operation unsafe. Check the wire periodically and adjust if necessary.

Do not strongly move the accelerating wire or accelerating pedal. It may deform the governor lever or stretch the wire to cause irregular engine speed control.

Checking and adjusting procedure are as follows.

- 1) Check that the governor lever of the engine makes uniform contact with the high idling and low idling limiting bolt when the accelerating devices is in the high idling speed or low idling speed position.
- 2) If either the high or the low idling speed side does not make contact with the limiting bolt, adjust the accelerating wire.
 

Loosen the accelerating wire fixing nut and adjust the wire to contact with the limiting bolt.

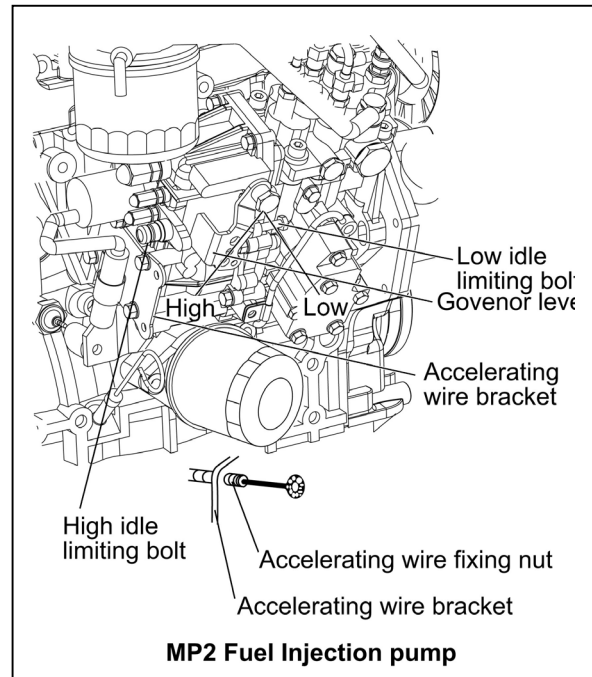

#### **CAUTION**

Never release the limiting bolts. It will impair the safety and performance of the product and functions and result in shorter engine life.

#### (5) Air cleaner cleaning and element replacement

#### **CAUTION**



#### Beware of dirt from air blowing

Wear protective equipment such as goggles to protect your eyes when blowing compressed air. Dust or flying debris can hurt eyes.

The engine performance is adversely affected when the air cleaner element is clogged by dust. So periodical cleaning after disassembly is needed.

- 1) Undo the clamps on the dust pan and remove the dust pan.
- 2) Loosen the wing bolt on the element and pull out the element.

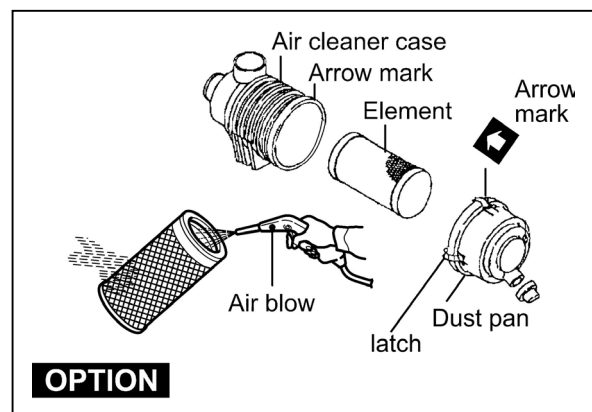

- 3) Blow air [0.29~0.49MPa (3.0~5.0kgf/cm<sup>2</sup>)] from inside the element to blow dust off as shown in the illustration right.  
Apply the air blowing pressure as low as possible so as not to damage the element.  
If having the air cleaner with double elements, never remove and clean the inner element.  
The aim of installing the inner element is for back up protecting from intaking dust during engine running when leaving the outer element to reinstall after removing it or when damaging the outer element unexpectedly during engine running.
- 4) Replace the element with new one, If the element is damaged, excessively dirty or oily.
- 5) Remove the inside dust cover of the dust pan, and clean inside of the dust pan.
- 6) Reinstall the element with the wing bolt. (do not leave the gasket.) Reattach the inside dust cover to the dust pan and install the dust pan to the air cleaner case placing the TOP mark upward.

**IMPORTANT:**

- When the engine is operated in dusty conditions, clean the element more frequently.
- Do not run the engine with removed air cleaner or element, as this may cause foreign material to enter and damage the engine.

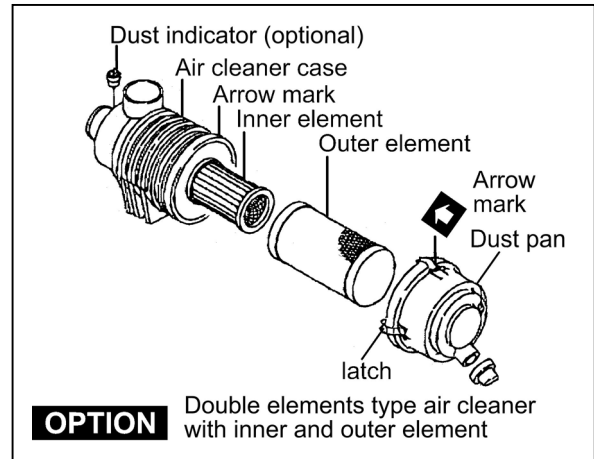

## 2.2.5 Inspection every 500 hours or 6 months

Be sure to check the following points every 500 hours or 6 months operation, whichever comes first.

No.	Inspection Item
(1)	Water separator cleaning
(2)	Fuel filter element replacement
(3)	Air cleaner cleaning and element replacement

### (1) Water separator cleaning

Periodically wash the water separator element and inside cup with clean fuel oil.

- 1) Prepare a waste oil container.
- 2) Close the fuel cock.
- 3) Loosen the drain cock and drain.  
Refer to 2.2.3.(2)
- 4) Turn the retaining ring counter-clockwise and remove the cup.  
(Disconnect the coupler of the lead wire for drain sensor before removing the cup if it is with drain sensor).
- 5) Wash the element and inside cup with clean fuel oil. Replace the element with new one if any damaged.

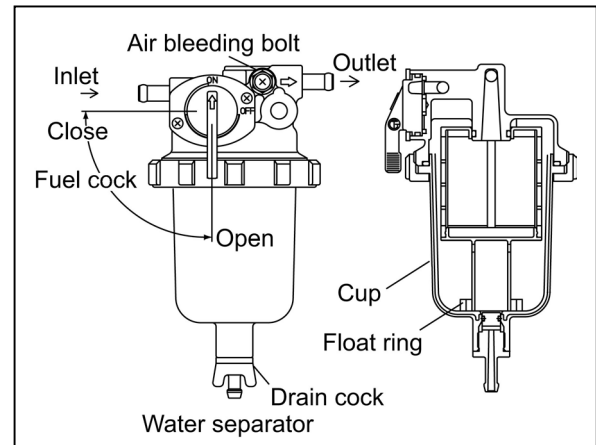

Model	Applicable element	Part No.
3TNV82A~ 4TNV106(T)		119802-55710

- 6) Insert the element to the bracket (O-ring) and after putting the float ring in the cup, install it to the bracket by tightening the retaining ring clockwise.  
Tightening torque: 15~20Nm (1.5~2.0kgf-m)
- 7) Close the drain cock (connect the coupler if with drain sensor).
- 8) Bleed the fuel system. Refer to 2.2.3.(3)

**(2) Fuel filter element replacement**

Replace the fuel filter at specified intervals, before it is clogged with dust to adversely affect the fuel flow. Also, replace the fuel filter after the engine has fully been cooled.

- 1) Close the fuel cock of the water separator.
- 2) Remove the fuel filter using a filter wrench(customer procured). When removing the fuel filter, hold the bottom of the fuel filter with a piece of rag to prevent the fuel oil from dropping. If you spill fuel, wipe such spillage carefully.
- 3) Clean the filter mounting surface and slightly apply fuel oil to the gasket of the new fuel filter.
- 4) Install the new fuel filter manually turning until it comes into contact with the mounting surface, and tighten it further to 1/2 of a turn using a filter wrench.

Tightening torque for 3TNV82A to 4TNV106(T):  
20~24N·m(2.0~2.4kgf·m)

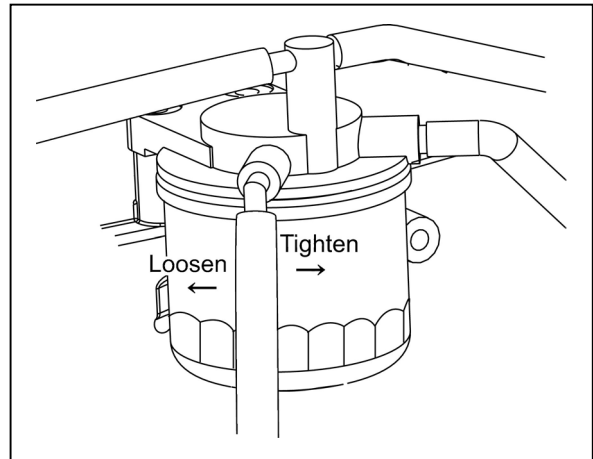

Model	Applicable fuel filter Part No.
3TNV82A~ 4TNV88	119802-55800
4TNV98(T)~ 4TNV106(T)	123907-55800

- 5) Bleed the fuel system. Refer to 2.2.3.(3)

**IMPORTANT:**

Be sure to use genuine Yanmar part (super fine mesh filter). Otherwise, it results in engine damage, uneven engine performance and shorten engine life.

**(3) Air cleaner cleaning and element replacement**

Replace the air cleaner element periodically even if it is not damaged or dirty.

When replacing the element, clean inside of the dust pan at the time.

If having the air cleaner with double elements, do not remove the inner element. If the engine output is still not recover (or the dust indicator still actuates if having the air cleaner with a dust indicator) even though the outer element has replaced with new one, replace the inner element with new one.

### 2.2.6 Inspection every 1,000 hours or one year

Be sure to check the following points every 1,000 hours or one year operation, whichever comes first.

No.	Inspection Item
(1)	Coolant water replacement
(2)	Diaphragm assy inspection
(3)	Turbocharger blower cleaning*
(4)	Intake/exhaust valve clearance adjustment
(5)	Fuel injection nozzle pressure inspection

#### (1) Coolant water replacement

Coolant water contaminated with rust or water scale reduces the cooling effect. Even when antifreeze agent (LLC) is mixed, the coolant water gets contaminated due to deteriorated ingredients. Replace the coolant water at least once a year.

- 1) Remove the radiator cap.
- 2) Loosen the drain plug at the lower portion of the radiator and drain the coolant water.
- 3) After draining the coolant water, tighten the drain plug.
- 4) Fill radiator and engine with coolant water. Refer to 3.4

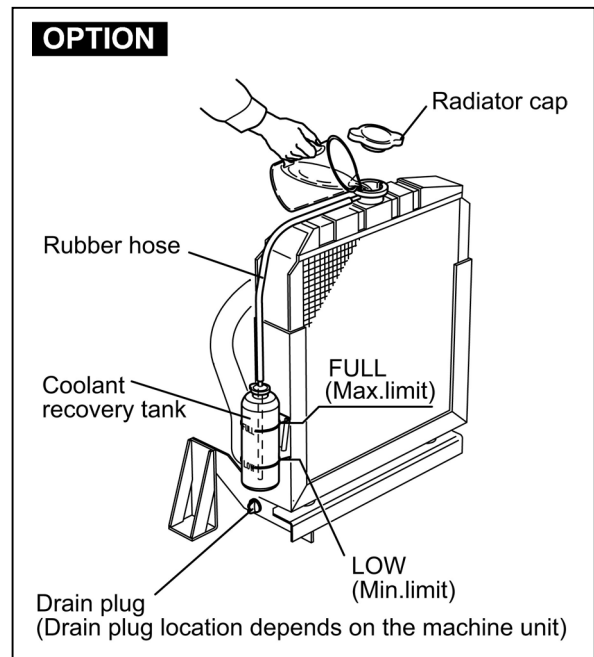

**CAUTION**



#### Beware of scalding by hot water

Wait until the temperature goes down before draining the coolant water. Otherwise, hot water may splash to cause scalding.

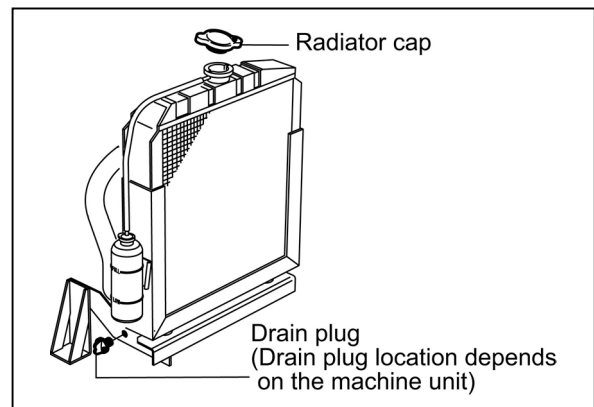



## (2) Diaphragm assy inspection

Inspect the diaphragm assy on the rocker arm cover every 1000 hours or **2 years**. Refer to 4.2.4 point 6 for the function of the diaphragm.

- 1) Loosen screws, and remove a diaphragm assy, and check whether oil and so on doesn't enter between the diaphragm and the cover. If oil and so on enters into the diaphragm assy, the diaphragm doesn't work well.
- 2) Check the damages of the diaphragm rubber and the spring. If necessary, replace with new ones.

### [NOTICE]

- When a diaphragm is damaged, pressure control inside the crankcase becomes insufficient, and troubles such as combustion defect and so on occur.
- At lubricating oil replacement or lubricating oil supply, the amount of lubricating oil isn't to be beyond the standard upper limit. If the lubricating oil quantity is beyond the upper limit or an engine is operated beyond the allowable maximum angle of an engine, the amount of oil mist may be inducted in the combustion chamber and the oil hammer sometimes may occur.

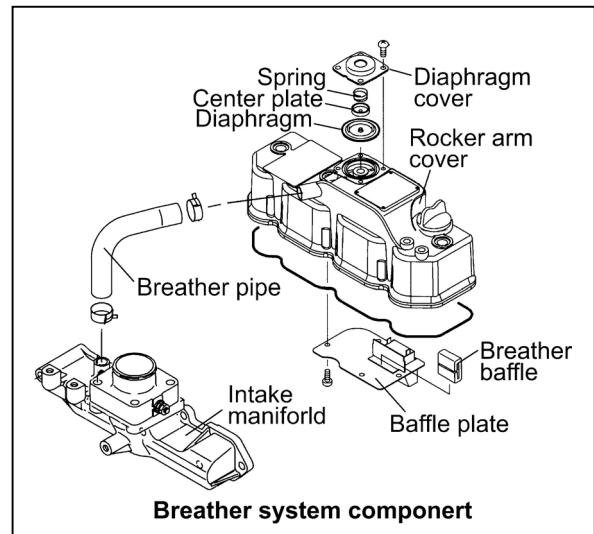

**(3) Turbocharger blower cleaning\***

When engine speed seems sluggish or the exhaust color looks poor, the blades of the turbocharger-blower may be dirty.

Wash the turbine blower in such a case.

**(a) General items**

- 1) As for washing, use washing liquid and clear water.
- 2) Washing time is the time when about 10% of the boost pressure decreases more than that of usual operation state as a standard.
- 3) Disassemble and clean a turbocharger periodically because the whole of the turbocharger can't be cleaned in this method.

**(b) Washing point**

- 1) A specified quantity of washing liquid/water is poured with a filler (ex. Oil sprayer) from the air inlet of the blower gradually (about then seconds) at the normal load (3/4-4/4) of an engine. And, perform this work at no-load after load running of the engine, if it is difficult to pour the liquid into the blower at load running.

Specified quantity of washing liquid/water

Turbocharger model	RHB31, RHB51
Injection amount, one time	20 cc

**⚠ CAUTION**

It causes an accident when large quantity of washing liquid is poured rapidly into a turbocharger.

- 2) Pour the same amount of clear water as washing liquid/water into the blower about 3-5 minutes later after the washing liquid/water injection and wash it.

**⚠ CAUTION**

It causes an accident when large quantity of water is poured rapidly into a turbocharger.

- 3) Repeat the washing after then minutes when there is no change with the boost pressure or the exhaust gas temperature after washing.  
When there is no change at all even if it repeats 3-4 times, disassemble and maintain the turbocharger because of the cruel dirt of the blower or other causes.
- 4) Operate the engine at load for at least 15 minutes after washing, and dry.

(4) Intake/exhaust valve clearance adjustment  
 Make measurement and adjustment while the engine is cold.

(a) Valve clearance measurement

- 1) Remove the rocker arm cover above cylinder head.
- 2) Set the No.1 cylinder in the compression TDC  
 Turn the crankshaft to bring the piston of the No.1 cylinder to its compression top dead center while watching the rocker arm motion, timing scale and the top mark position of the crankshaft pulley.  
 (Position where both the intake and exhaust valves are closed.)

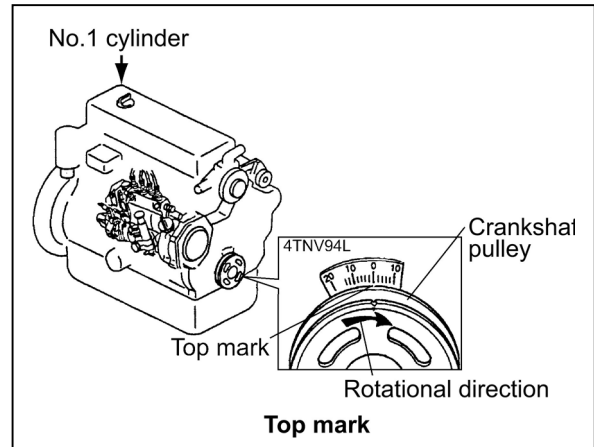

Notes:

- The crankshaft shall be turned clockwise as seen from the radiator side.
- The No.1 cylinder position is on the opposite side of the radiator and the ignition order shall be 1-3-4-2-1 at 180° intervals.
- Since the intake and exhaust valve rocker arms are operated the same and there is a clearance between the arm and valve generally at the top dead center, the position can be checked by means of the play when the arm head is held with a hand. Also see that the crankshaft pulley top mark is positioned at zero on the timing scale. If there is no valve clearance, inspection in the disassembled state is necessary since the valve seat may be worn abnormally.

3) Valve clearance measurement

In case of 2-valve cylinder head insert a thickness gage between the rocker arm and valve cap, and record the measured valve clearance.  
 In case of 4-valve head insert a thickness gage between the rocker arm and the valve bridge, and record the measured valve clearance.  
 (Use it as the data for estimating the wear state.)

4) Adjusting other cylinders

In case of 4-cylinder engines, turn the crankshaft 180° and make adjustment for the No.3 cylinder. Then adjust the No.4 and No.2 cylinders in this order.

The cylinder to be adjusted first does not have to be the No.1 cylinder. Select and adjust the cylinder where the piston is the nearest to the top dead center after turning, and make adjustment for other cylinders in the order of ignition by turning the crankshaft 180° each time.

In case of 3-cylinder engines, turn the crankshaft 240° and make adjustment for the No.3 cylinder. Then adjust the No.2 cylinder in this order.

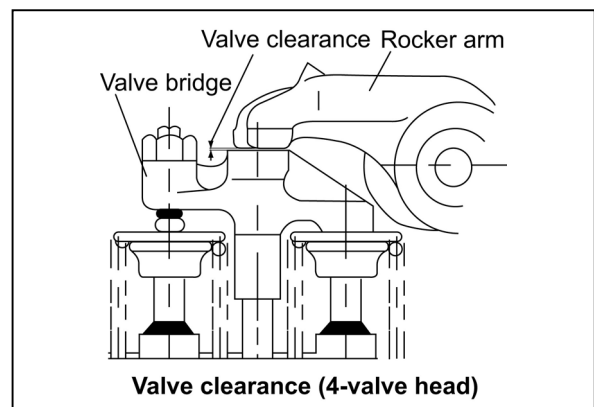
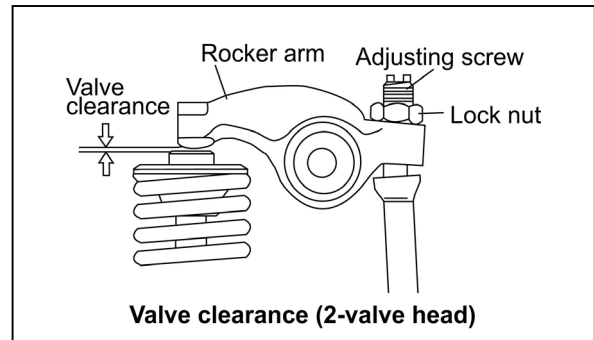

The cylinder to be adjusted first does not have to be the No.1 cylinder. Select and adjust the cylinder where the piston is the nearest to the top dead center after turning, and make adjustment for other cylinders in the order of ignition by turning the crankshaft 240° each time.

The adjustment method of reducing the flywheel turning numbers (for reference):

For 3 cylinder engines

Set No.1 cylinder to the compression T.D.C. and adjust the clearance of the ● mark of the below table. Next, turn the flywheel once (the suction / exhaust valve of No.1 cylinder is in the position of the overlap T.D.C. at this time), and adjust the clearance of the ○ mark.

Ignition order of 3 cylinder engines: 1→3→2

Cylinder No.	1		2		3	
	Suction	Exhaust	Suction	Exhaust	Suction	Exhaust
No.1 compression T.D.C	●	●	●			●
No.1 overlap T.D.C				○	○	

The first time

The second time

For 4 cylinder engines

Set No.1 cylinder to the compression T.D.C. and adjust the clearance of the ● mark of the bottom table. Next, turn the flywheel once, and adjust the clearance of the ○ mark.

Ignition order of 3 cylinder engines: 1→3→4→2

Cylinder No.	1		2		3		4	
	Suction	Exhaust	Suction	Exhaust	Suction	Exhaust	Suction	Exhaust
No.1 compression T.D.C	●	●	●			●		
No.4 compression T.D.C				○	○		○	○

The first time

The second time

(b) Valve clearance inspection and adjustment

1) Loosen adjusting bolts

In case of 2-valve cylinder head loosen the lock nut and adjusting screw, and check the valve for any inclination of valve cap, entrance of dirt or wear.

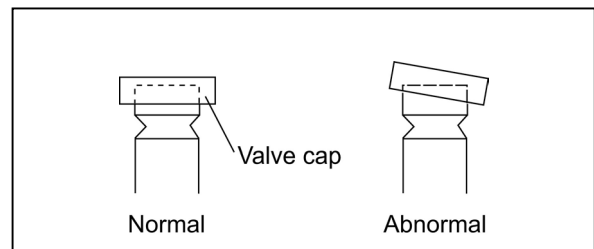

In case of 4-valve cylinder head loosen the lock nut and adjusting screw of rocker arm. Be careful that excessive tension isn't applied to the valve bridge, and loosen a locknut of valve bridge.

[NOTICE]

When loosening a locknut of a valve bridge, loosen the locknut while fixing the valve bridge with a wrench so that the valve may not lean.

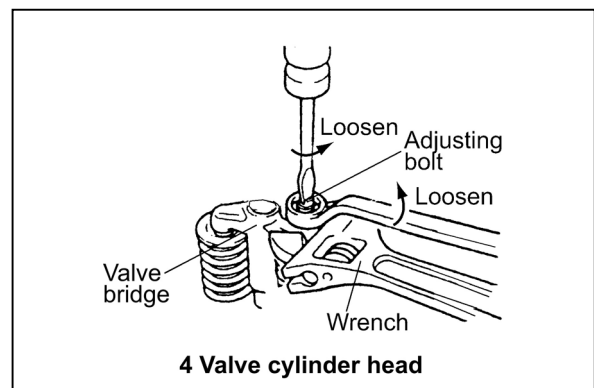

4 Valve cylinder head

Push the bridge head so that a valve bridge and two valve stem heads may contact each other uniformly, and adjust an adjusting bolt so that a gap of the valve stem head may become 0. Tighten a locknut after a valve bridge is fixed with a wrench.

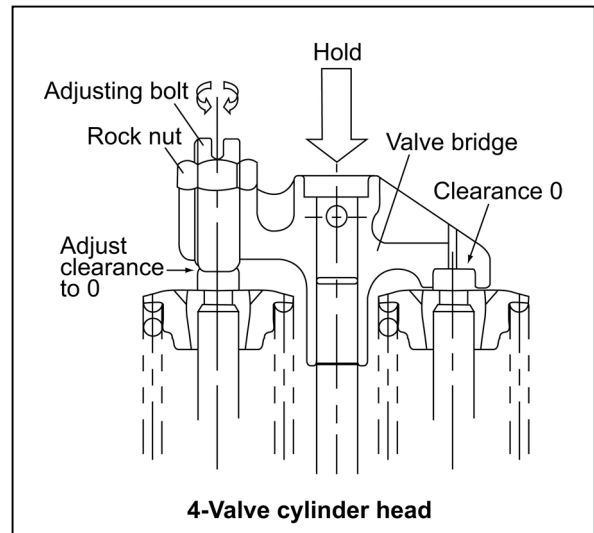

2) Measuring valve clearance

Insert a 0.2 or 0.3 mm thickness gage between the rocker arm and valve cap / valve bridge, and adjust the valve clearance. Tighten the adjusting screw.

Model	Standard valve clearance	mm
3TNV82A~98	0.15~0.25	
4TNV106(T)	0.25~0.35	

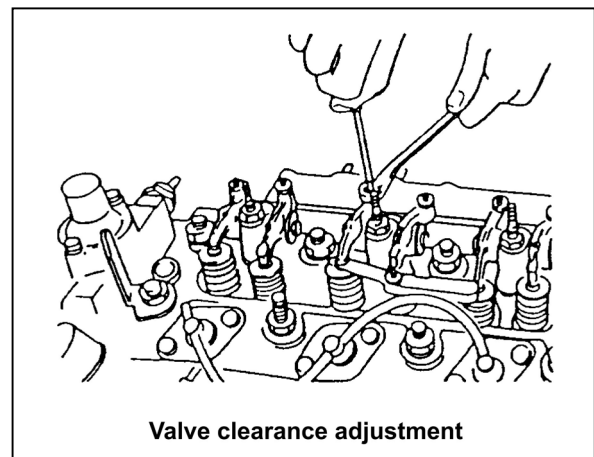

[NOTICE]

When tightening a valve bridge locknut of 4-valve head, tighten a locknut after fixing a valve bridge with a wrench so that a bridge may not rotate and a valve may not lean.

3) Apply oil to the contact surface between adjusting screw and push rod.

4) Adjusting other cylinders

In case of 4-cylinder engines turn the crankshaft 180° then and make adjustment for the No.3 cylinder. Then adjust the No.4 and No.2 cylinders in this order.

The cylinder to be adjusted first does not have to be the No.1 cylinder. Select and adjust the cylinder where the piston is the nearest to the top dead center after turning, and make adjustment for other cylinders in the order of ignition by turning the crankshaft 180° each time.

In case of 3-cylinder engines turn the crankshaft 240° then and make adjustment for the No.3 cylinder. Then adjust the No.2 cylinder in this order.

The cylinder to be adjusted first does not have to be the No.1 cylinder. Select and adjust the cylinder where the piston is the nearest to the top dead center after turning, and make adjustment for other cylinders in the order of ignition by turning the crankshaft 240° each time.

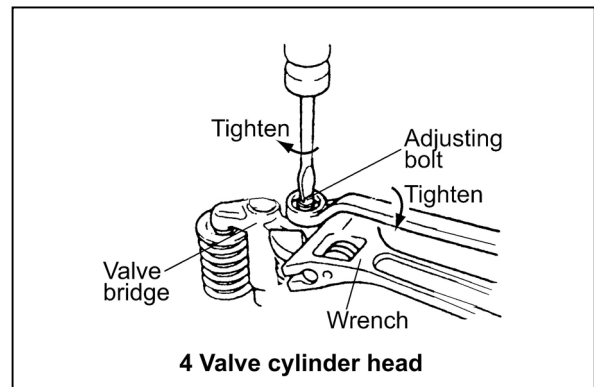

## (5) Fuel injection nozzle pressure inspection

**⚠ CAUTION**

Wear protective glasses when testing injection from the fuel injection valve. Never approach the injection nozzle portion with a hand. The oil jetting out from the nozzle is at a high pressure to cause loss of sight or injury if coming into careless contact with it.

## (a) Injection pressure measurement

Model	Standard MPa(kgf/cm <sup>2</sup> )
3TNV82A~TNV88 (CL )	19.6-20.6 (200-210)
3TNV82A~TNV88 (VM )	21.6-22.6 (220-230)
4TNV94L~4TNV106(T)	

**[NOTICE]**

As for the opening pressure of the brand-new fuel nozzle, about 0.5Mpa(5kgf/cm) declines by the engine operation for about 5 hours because of the initial wear-out of a spring etc. Therefore, adjust 0.5MPa(5kgf/cm) higher than the standard value of the above table when adjusting a new fuel nozzle of a spare part.

Remove carbon deposit at the nozzle hole thoroughly before measurement.

- 1) Connect the fuel injection valve to the high pressure pipe of the nozzle tester.
- 2) Operate the nozzle tester lever slowly and read the pressure at the moment when the fuel injection from the nozzle starts.
- 3) If the measured injection pressure is lower than the standard level, replace the pressure adjusting shim with a thicker one.

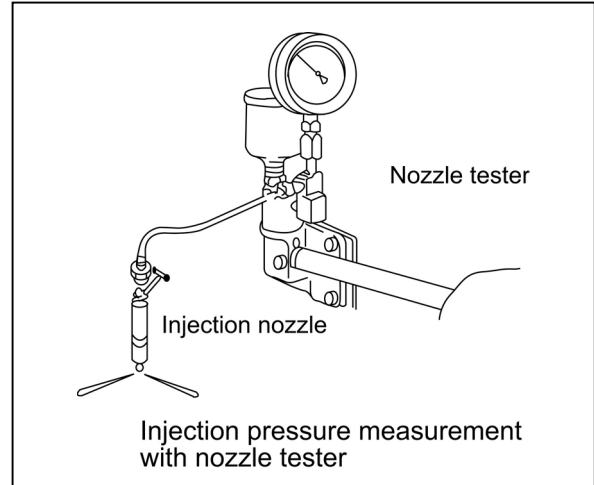

Thickness of pressure adjusting shims mm	Injection pressure adjustment
0.13, 0.15, 0.18, 0.4, 0.5, 0.8	The injection pressure is increased by approx. 1.9 MPa(19 kgf/cm <sup>2</sup> ), when the adjusting shim thickness is increased by 0.1 mm.

[Informative: Fuel injection valve structure]

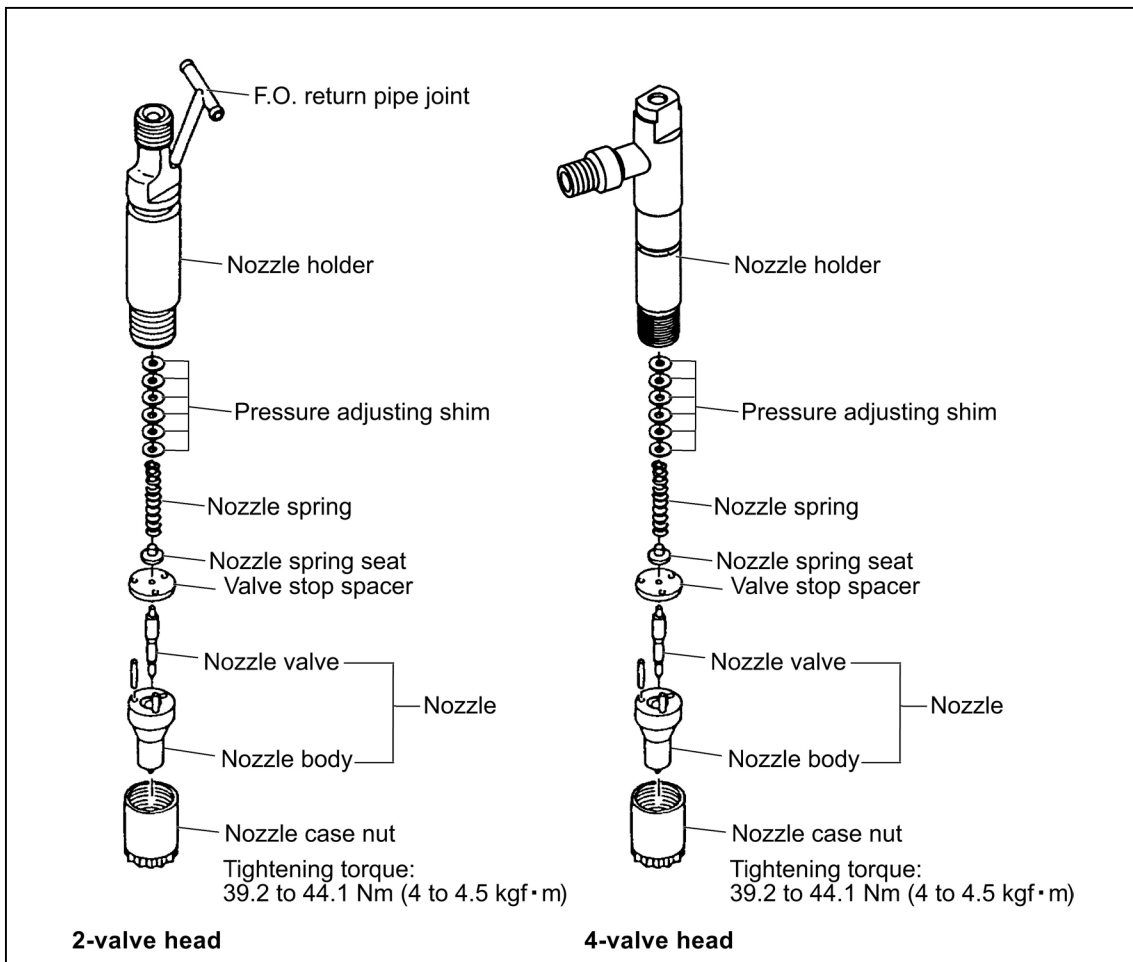

(b) Spray pattern inspection

After adjustment to the specified valve opening pressure, use a nozzle tester and check the spray pattern and seat oil-tightness.

**Seat oil tightness check**

- After injecting a few times, increase the pressure gradually. Hold the pressure for about 5 seconds at a little before the valve opening pressure of 1.96 MPa(20kgf/cm<sup>2</sup>), and check to see that oil does not drip from the tip end of the nozzle.
- If extreme oil leak from the overflow joint exists during injection by the nozzle tester, check after retightening. If much oil is leaking, replace the nozzle assembly.

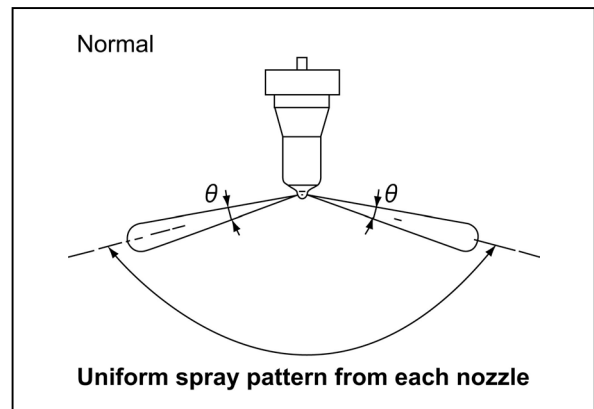

**Spray and injection states**

- Operate the nozzle tester lever at a rate of once or twice a second and check no abnormal injection.
- If normal injection as shown below cannot be obtained, replace the fuel injection valve.
- No extreme difference in angle( $\theta$ )
- No extreme injection angle difference( $\alpha$ )
- Finely atomized spray
- Excellent spray departure

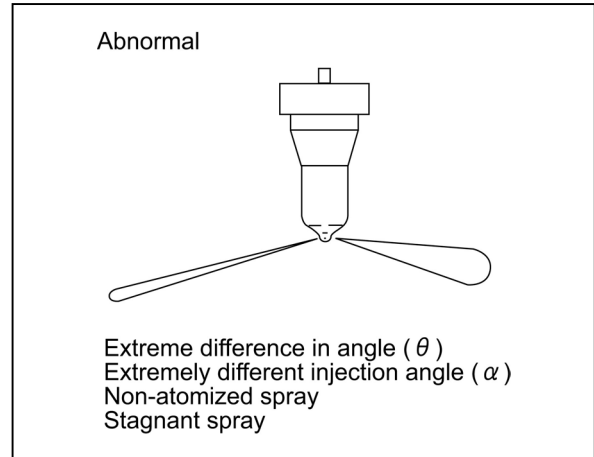

**(c) Nozzle valve sliding test**

Wash the nozzle valve in clean fuel oil. Place the nozzle body vertically and insert the nozzle into the body to about 1/3 of its length. The valve is normal if it smoothly falls by its own weight into the body. In case of a new nozzle, remove the seal peel, and immerse it in clean diesel oil or the like to clean the inner and outer surfaces and to thoroughly remove rust-preventive oil before using the nozzle. Note that a new nozzle is coated with rust-preventive oil and is pasted with the seal peel to shut off outer air.

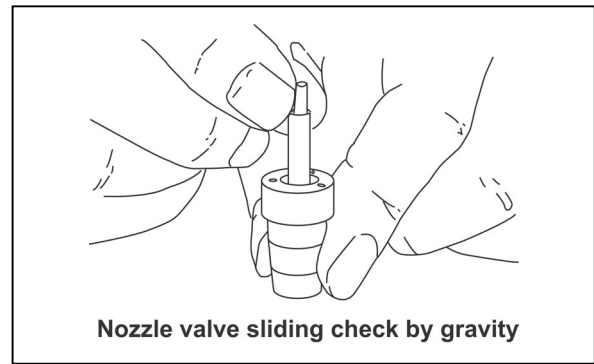

**(d) Nozzle punch mark**

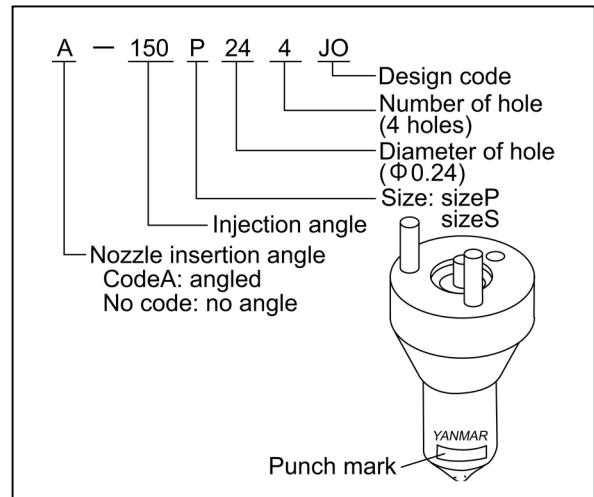



### 2.2.7 Inspection every 2000 hours or 2 years

Be sure to check the following points every 2,000 hours or two years operation, whichever comes first.

No.	Inspection Item
(1)	Coolant water path flushing and maintenance
(2)	Fuel pipe and coolant water pipe inspection and maintenance
(3)	Intake/exhaust valve seat lapping
(4)	Fuel injection timing adjustment Fuel injection pump inspection and adjustment

#### (1) Coolant water path flushing and maintenance

Rust and water scale will accumulate in the cooling system through many hours of operation. This lowers the engine cooling effect. Oil coolers (attached to turbocharged engines and some of naturally aspirated engines) quickly deteriorate the lube oil. The cleaning and maintenance of the following parts are necessary in accordance with the coolant water replacement.

Cooling system parts: radiator, cooling water pump, thermostat, cylinder block, cylinder head, oil cooler.

#### (2) Fuel pipe and coolant water pipe inspection and maintenance

Regularly check the rubber hoses of the fuel system and cooling water system. If cracked or degraded, replace them with new one. Replace the rubber hoses at least every 2 years even if 2,000 hours doesn't come.

#### (3) Intake/exhaust valve seat lapping

The adjustment is necessary to maintain proper contact of the valves and seats. Refer to 4.2.6 in Chapter 4.

#### (4) Fuel injection timing adjustment / Fuel injection pump inspection and adjustment

The fuel injection timing and the fuel injection pump are adjusted so that engine performance may become the best condition. As for the inspection and adjustment of the fuel pump, it is based on the service manual of the MP pump of the separate volume. The fuel injection timing is adjusted by the following procedure.

As for the engine, which adopts a MP type fuel injection pump, the fuel injection angle  $\theta_i$  (note) is adjusted for the fuel injection timing adjustment, because the adjusting method of fuel injection timing like an inline fuel pump can't be applied.

Note) The fuel injection angle  $\theta_i$  (cam angle) is the difference from the injection valve opening angle while the fuel injection pump being driven by a motor and the angle at the plunger lift 2.5mm of the fuel pump.

And, as for the actual fuel injection angle  $\theta_i$ , the measured value is recorded on the pump body by each every fuel pump.

#### The adjustment of fuel injection angle $\theta_i$

In case that a fuel pump cover, installed with a gear case cover and the fuel pump are removed, and reassembled, the procedure of fuel injection angle adjustment is as follows. (As for the disassembly of a fuel injection pump, refer to 7.2.3 in chapter 7.)

#### [NOTICE]

Never loosen four flange bolts, which fasten a pump flange and a fuel pump drive gear at the time of the removal of the fuel pump. When it is loosened, the adjustment of the fuel injection timing becomes very difficult.

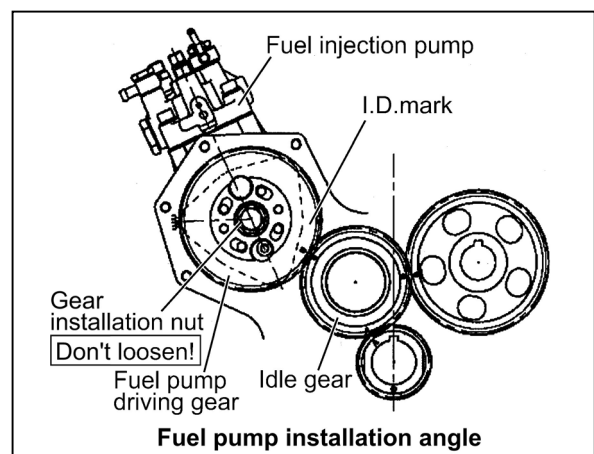
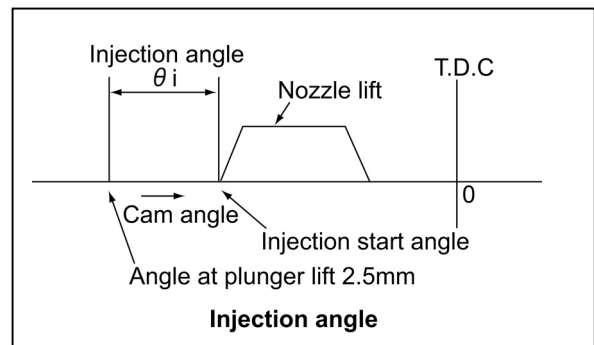

- 1) Before removing a fuel pump drive gear, make ID marks on the gearing part of the pump drive gear and the idle gear with paint and so on.
- 2) Make the mark-off line to the gear case precisely in accordance with the position of mark-off line of the fuel pump.
- 3) Before removing a fuel pump, put the standard mark of a sticker for fuel injection angle adjustment in accordance with the mark-off line of the fuel pump and paste it on the gear case.

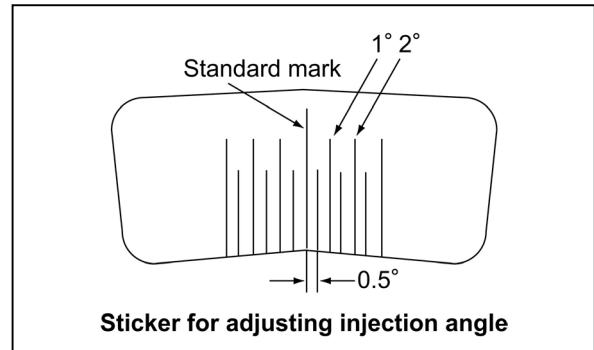
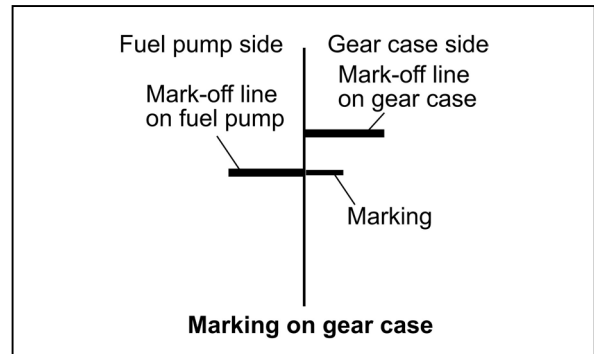

- 4) Remove a fuel pump, and read the fuel injection angle recorded in that fuel pump.

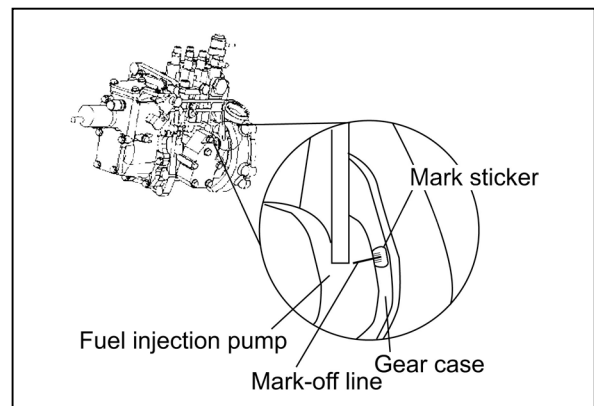

- 5) Read the injection angle recorded on a reassembled fuel pump and calculate the difference from the injection angle of the disassembled fuel pump. (When re-installation does the same fuel pump, the angular difference is zero.)

$$\text{Fuel injection angle difference (cam angle)} = (\text{the fuel injection angle of a reassembled fuel pump}) - (\text{the fuel injection angle of a disassembled previous fuel pump})$$

[NOTICE]

Tell the fuel pump number to Yanmar, and inquire the injection angle of the pump when it is hard to find out.

- 6) Put the fuel pump on the gear case temporarily and install the drive gear on the cam shaft with checking the ID marks, which were put on the fuel pump drive gear and the idle gear at the time of the disassembling.

Tighten the installation nut of a pump drive gear.

Model	Tightening torque Nm(kgf·m)	Lubricating oil application (thread portion, and seat surface)
3TNV82A~TNV88	78~88 (8~9)	Not applied
4TNV94L/98/106(T)	113~123 (11.5~12.5)	

7) Adjust the injection angle difference, calculated in the above 5), at  $0.25^\circ$  in the unit in the installation angle of the fuel pump while reading the mark (minimum  $0.5^\circ$  and cam angle) of the adjustment sticker.

[NOTICE]

Push down the fuel pump in the outside direction of the cylinder block at  $+1$  degree when a injection angle difference is  $+1$  degree. And, push it down to the cylinder block side when a difference is  $-1$  degree.

8) Tighten the fuel pump installation nuts.

**(Supplementary explanation 1)**

The installation angle of the fuel pump is as follows.

Model	Installation angle $\theta$ (deg.)
3TNV82A~TNV88	25
4TNV94L/98/106(T)	13
4TNV106(T)	11.5

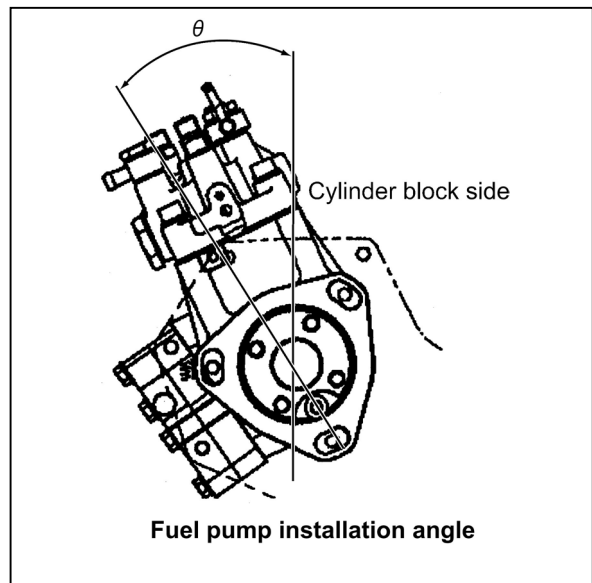
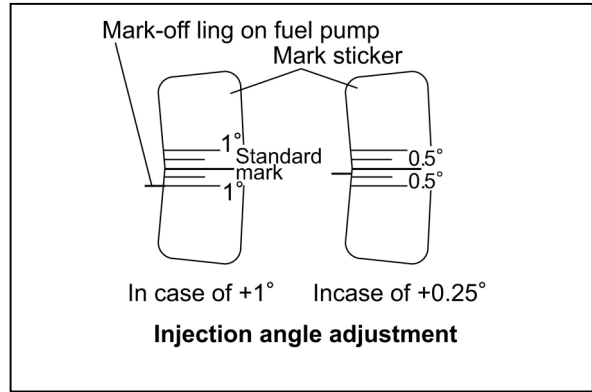

**(Supplementary explanation 2)**

When fuel injection timing is advanced or delayed, the installation angle of the fuel pump is adjusted. When fuel injection timing is advanced for example at 2 degrees, loosen the nuts, which fix the fuel pump on the gear case, and turn the fuel pump body in the outside direction of the cylinder block at 1 degree, and tighten the pump installation nuts. And, when fuel injection timing is delayed, a pump is turned in that reverse direction.

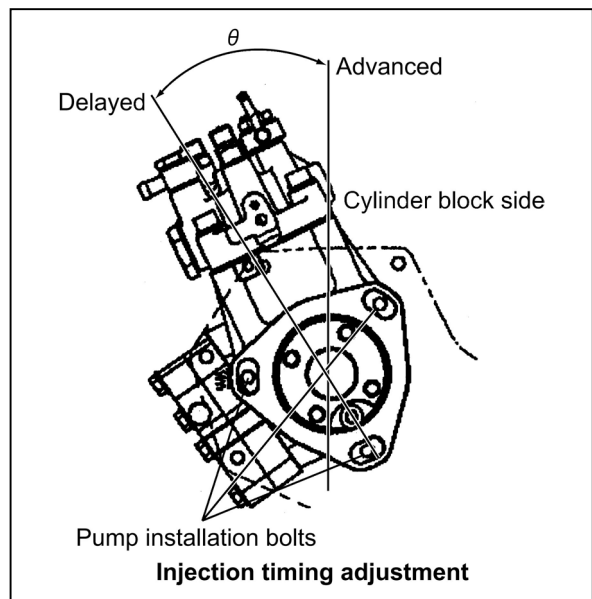

## 2.3 Adjusting the no-load maximum or minimum speed

- 1) After warming the engine up, gradually raise the speed and set it at the no-load maximum revolution.
- 2) If the no-load maximum revolution is out of the standard, adjust it by turning the high idle limiting bolt.
- 3) Then set the no-load minimum speed by adjusting the low idle limiting bolt.

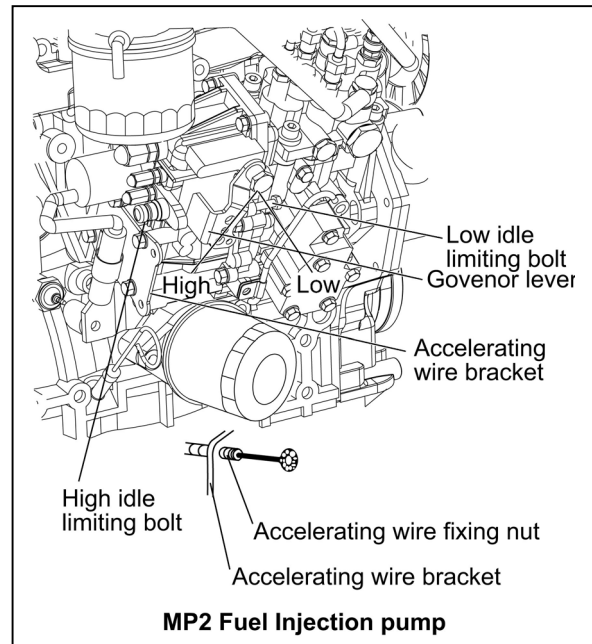

### Standards

(Unit: min<sup>-1</sup>)

Engine application class	Rating speed	No-load maximum	No-load minimum
CL	1500	1575-1625	1200 or more
	1800	1870-1920	
VM	2000	2180-2230	800 or more (1100 or more for 4TNV106(T) )
	2200	2395-2445	
	2400	2590-2640	
	2500	2700-2750	
	2600	2785-2835	
	2800	2970-3020	
	3000	3185-3235	

Note) The engine speed may differ from the above standard depending on an engine installed on a machine unit.

## 2.4 Sensor Inspection

### 2.4.1 Oil pressure switch

Disconnect the connector from the oil pressure switch. Keep the voltammeter probes in contact with the switch terminal and cylinder block while operating the engine. It is abnormal if circuit is closed.

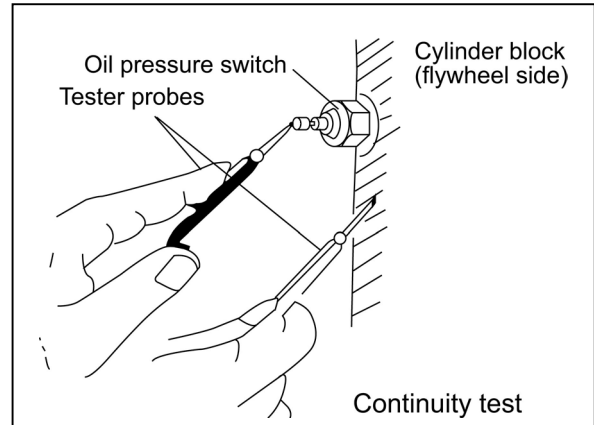

### 2.4.2 Thermo switch

Place the thermo switch in a container filled with antifreeze or oil. Heat it while measuring the fluid temperature. The switch is normal if the voltammeter shows continuity when the fluid temperature is 107~113 deg C.

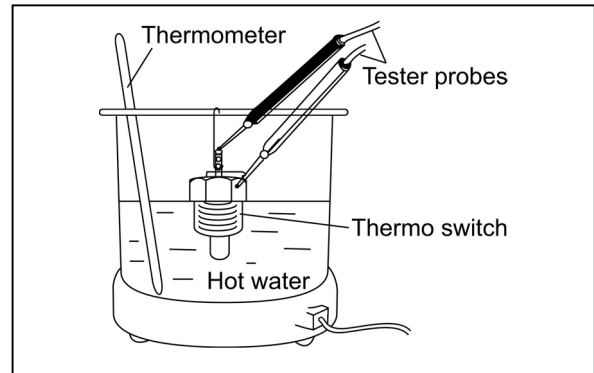

## 2.5 Water leak check in cooling water system

Check coolant water leakage from the cooling water system visually. If any problem is found, inspect as follows.

- 1) Fill coolant water to the normal level in the radiator, and install the cap tester on the radiator.
- 2) Operate the manual pump to set the pressure to  $0.09 \pm 0.015 \text{ MPa}$  ( $0.9 \pm 0.15 \text{ kgf/cm}^2$ ). If the cap tester pressure gage reading drops then, water is leaking from the cooling water system. Check the water leaking point.

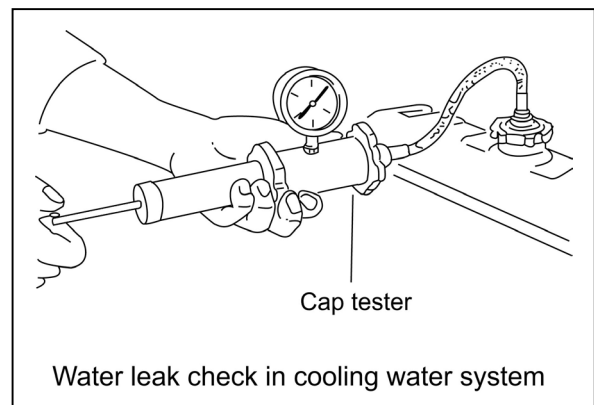

## 2.6 Radiator cap inspection

Install the radiator cap on the cap tester. Set the tester pressure to  $0.09 \pm 0.015 \text{MPa}$  ( $0.9 \pm 0.15 \text{kgf/cm}^2$ ) and see that the cap is opened. If the cap does not open, replace the cap since it is abnormal.

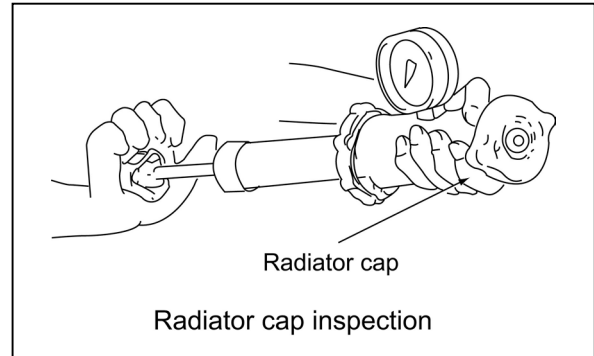

## 2.7 Thermostat Inspection

Place the thermostat in a container filled with water. Heat it while measuring the water temperature, and see that the thermostat is actuated at temperature of following table.

Model	Valve opening Temperature (deg C)*	Full open lift (Temperature) (mm)
All models	69.5~72.5	8 or more (85deg C)

\* Valve opening temperature is carved on the flange.

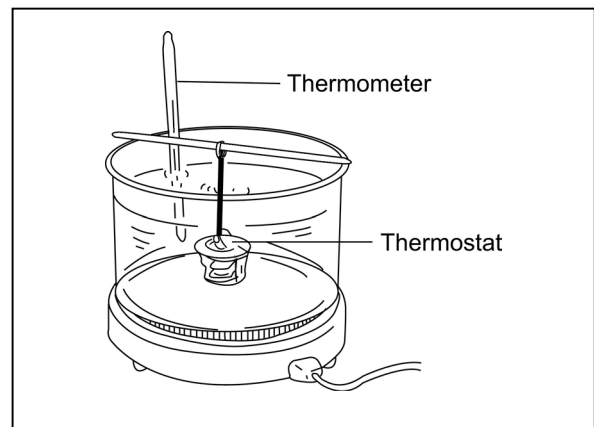
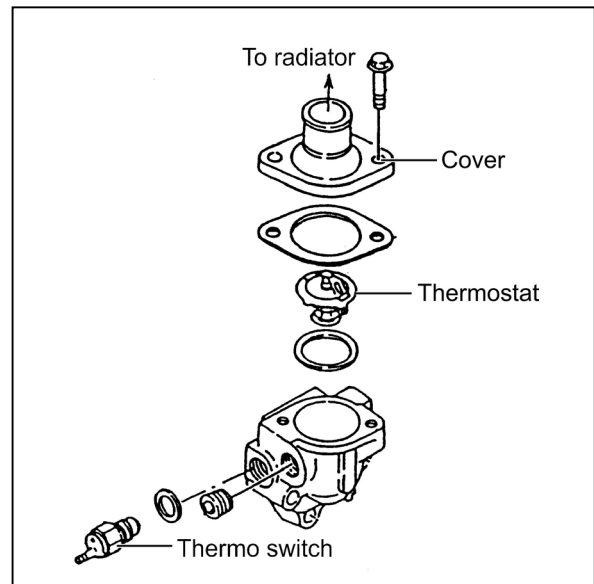

## 2.8 Adjusting Operation

Perform the adjusting operation of a engine as follows after the maintenance job:

- 1) Supply the fuel oil, lubricating oil and coolant water.

Note:

Check the levels of the lubricating oil and coolant water again after test running (for about 5 minutes) and add as required.

- 2) Start the engine, and carry out idling at a low revolution (700 to 900 rpm) for a few minutes.
- 3) Run in the engine for about five minutes at the rated revolution (no-load). Check any water, fuel or oil leak and existence of abnormal vibration or noise. Also check the oil pressure, coolant water temperature and exhaust gas color.
- 4) Adjust the no-load minimum and maximum revolutions according to the specifications.
- 5) Perform loaded operation as required.

## 2.9 Long storage

Observe the following instructions when the engine is to be stored for a long period without operation:

- 1) Always drain coolant water in a cold season or before a long storage.(This is unnecessary when antifreeze is used.)

[NOTICE]

Negligence of water draining will cause the coolant water remaining inside the engine to be frozen and expanded to damage the engine parts.

### Water draining procedure

- a) Remove the radiator cap.
  - b) Loosen the water draining cock under the radiator to drain water from the inside.
  - c) Loosen the drain cock on the side surface of the cylinder to drain water from the inside.
  - d) After draining water, tighten the radiator cap and drain plug and cocks.
- 2) Remove the mud, dust and oil deposit and clean the outside.
  - 3) Perform the nearest periodic inspection before the storage.
  - 4) Drain or fill the fuel oil fully to prevent condensation in the fuel tank.
  - 5) Disconnect the battery cable from the battery negative (-) terminal.
  - 6) Cover the silencer, air cleaner and electric parts with PVC cover to prevent water and dust from depositing or entrance.
  - 7) Select a well-ventilated location without moisture and dust for storage.
  - 8) Perform recharging once a month during storage to compensate for self-discharge.

## 3. TROUBLESHOOTING

### 3.1 Preparation before troubleshooting

If the signs of a trouble appear, it is important to lecture on the countermeasure and treatment before becoming a big accident not to shorten the engine life.

When the signs of a trouble appear in the engine or a trouble occurs, grasp the trouble conditions fully by the next point and find out the cause of sincerity according to the troubleshooting. Then repair the trouble, and prevent the recurrence of the trouble.

- 1) What's the occurrence phenomenon or the trouble situation? ..... (e.g. Poor exhaust color )
- 2) Investigation of the past records of the engine  
Check a client control ledger, and examine the history of the engine.
  - Investigate the engine model name and the engine number. (Mentioned in the engine label.)  
Examine the machine unit name and its number in the same way.
  - When was the engine maintained last time?
  - How much period and/or time has it been used after it was maintained last time?
  - What kind of problem was there on the engine last time, and what kind of maintenance was done?
- 3) Hear the occurrence phenomenon from the operator of the engine in detail.  
5W1H of the occurrence phenomenon : the investigation of when (when), where (where), who (who), what (what), why (why) and how (how)
  - When did the trouble happen at what kind of time?
  - Was there anything changed before the trouble?
  - Did the trouble occur suddenly, or was there what or a sign?
  - Was there any related phenomenon.  
.....(e.g. Poor exhaust color and starting failure at the same time)
- 4) After presuming a probable cause based on the above investigation, investigate a cause systematically by the next troubleshooting guide, and find out the cause of sincerity.



### 3.2 Quick Reference Table for Troubleshooting

The following table summarizes the general trouble symptoms and their causes. If any trouble symptom occurs, take corrective action before it becomes a serious problem so as not to shorten the engine service life.

Cause	Trouble symptom	Starting failure			Insufficient engine output			Poor exhaust color		High knocking sound during combustion	Abnormal engine sound	Uneven combustion sound	Hunting		Difficulty in returning to low speed	Excessive fuel consumption	Lubricating oil				Cooling water		Air intake		Corrective action	
		Engine does not start.	Engine starts but stops soon.		Exhaust color	Exhaust color	During work	During idling	During work				Large engine vibration	Excessive consumption			Dilution by fuel oil	Mixture with water	Low L.O. pressure	Much blow-by gas	Overheat	Low water temperature	Pressure drop	Pressure rise		Exhaust temperature rise
			None	Little																						
Engine system	Improper clearance of intake/exhaust valve	<input type="checkbox"/>	<input type="checkbox"/>		<input type="checkbox"/>					<input type="checkbox"/>													<input type="checkbox"/>	Adjust the valve clearance. (See 2.2.6 in Chapter2.)		
	Compression leakage from valve seat				<input type="checkbox"/>			<input type="checkbox"/>		<input type="checkbox"/>					<input type="checkbox"/>								<input type="checkbox"/>	<input type="checkbox"/>	Lap the valve seat. (See 4.2.6 in Chapter4.)	
	Seizure of intake/exhaust valve	<input type="checkbox"/>			<input type="checkbox"/>	<input type="checkbox"/>		<input type="checkbox"/>		<input type="checkbox"/>			<input type="checkbox"/>	<input type="checkbox"/>					<input type="checkbox"/>				<input type="checkbox"/>		Correct or replace.	
	Blowout from cylinder head gasket				<input type="checkbox"/>														<input type="checkbox"/>				<input type="checkbox"/>		Replace the gasket. (See 4.2.2-11) in Chapter4.)	
	Seized or broken piston ring	<input type="checkbox"/>			<input type="checkbox"/>	<input type="checkbox"/>		<input type="checkbox"/>		<input type="checkbox"/>		<input type="checkbox"/>	<input type="checkbox"/>				<input type="checkbox"/>	<input type="checkbox"/>					<input type="checkbox"/>	<input type="checkbox"/>	Replace the piston ring. (See 4.2.2-5)10) in Chapter4.)	
	Worn piston ring, piston or cylinder	<input type="checkbox"/>			<input type="checkbox"/>	<input type="checkbox"/>		<input type="checkbox"/>									<input type="checkbox"/>	<input type="checkbox"/>					<input type="checkbox"/>		Perform honing and use oversize parts. (See 4.4.5-1)4) and 4.4.6 in Chapter4.)	
	Seized crankpin metal or bearing	<input type="checkbox"/>	<input type="checkbox"/>							<input type="checkbox"/>		<input type="checkbox"/>	<input type="checkbox"/>	<input type="checkbox"/>									<input type="checkbox"/>		Repair or replace.	
	Improper arrangement of piston ring joints		<input type="checkbox"/>			<input type="checkbox"/>											<input type="checkbox"/>						<input type="checkbox"/>		Correct the ring joint positions. (See 4.4.4-6 in Chapter4.)	
	Reverse assembly of piston rings					<input type="checkbox"/>		<input type="checkbox"/>									<input type="checkbox"/>						<input type="checkbox"/>		Reassemble correctly. (See 4.4.4-6 in Chapter4.)	
	Worn crankpin and journal bearing					<input type="checkbox"/>				<input type="checkbox"/>		<input type="checkbox"/>	<input type="checkbox"/>	<input type="checkbox"/>									<input type="checkbox"/>		Measure and replace. (See 4.4.5-2) in Chapter4.)	
	Loosened connecting rod bolt									<input type="checkbox"/>				<input type="checkbox"/>									<input type="checkbox"/>		Tighten to the specified torque. (See 4.4.4-2 in Chapter4.)	
	Foreign matter trapped in combustion chamber	<input type="checkbox"/>								<input type="checkbox"/>						<input type="checkbox"/>							<input type="checkbox"/>		Disassemble and repair.	
	Excessive gear backlash									<input type="checkbox"/>													<input type="checkbox"/>		Adjust gear meshing. (See 4.3.4-2 in Chapter4.)	
	Worn intake/exhaust valve guide					<input type="checkbox"/>											<input type="checkbox"/>						<input type="checkbox"/>		Measure and replace. (See 4.2.5-2) and 4.2.7 in Chapter4.)	
	Defective governor		<input type="checkbox"/>									<input type="checkbox"/>	<input type="checkbox"/>	<input type="checkbox"/>	<input type="checkbox"/>										Make adjustment.	
Improper open/close timing of intake/exhaust valves	<input type="checkbox"/>				<input type="checkbox"/>	<input type="checkbox"/>	<input type="checkbox"/>	<input type="checkbox"/>		<input type="checkbox"/>														Adjust the valve clearance. (See 2.2.6-3) in Chapter2.)		
Turbocharger	Fouled blower							<input type="checkbox"/>	<input type="checkbox"/>															Wash the blower.		
	Waste gate malfunction							<input type="checkbox"/>	<input type="checkbox"/>															Disassemble and inspect.		
	Worn floating bearing					<input type="checkbox"/>		<input type="checkbox"/>																Disassemble and inspect.		

Cause	Trouble symptom	Starting failure			Insufficient engine output			Poor exhaust color		High knocking sound during combustion	Abnormal engine sound	Uneven combustion sound	Hunting		Difficulty in returning to low speed	Excessive fuel consumption	Lubricating oil				Cooling water		Air intake		Corrective action		
		Engine does not start.	Engine starts but stops soon.		Exhaust color			During work					Excessive consumption	Dilution by fuel oil			Mixture with water	Low L.O. pressure	Much blow-by gas	Overheat	Low water temperature	Pressure drop	Pressure rise	Exhaust temperature rise			
			None	Little	Much	Ordinary	White	Black	White																	Black	
Cooling Water System	Excessive cooling effect of radiator								○							○									Defective thermostat (kept closed) (See 2.2.7 in Chapter2.)		
	Insufficient cooling effect of radiator																					○			○	Defective thermostat (kept opened)(See 2.2.7 in Chapter2.) or slipping fan belt (See 2.2.2-2) in Chapter2.)	
	Insufficient coolant water level																								○	Check water leakage from cooling water system. (See 2.2.1-4) in Chapter2.)	
	Cracked water jacket																								○	Repair or replace.	
	Slackened fan belt																								○	Adjust the belt tension. (See 2.2.2-2) in Chapter2.)	
	Defective thermostat																								○	Check or replace. (See 2.2.7 in Chapter2.)	
Lubricating System	Improper properties of lubricating oil	○	○			○																				Use proper lubricating oil. (See 1.3.2 in Chapter1.)	
	Leakage from lubricating oil piping system																									Repair.	
	Insufficient delivery capacity of trochoid pump																									Check and repair. (See 5.5 in Chapter5.)	
	Clogged lubricating oil filter																									Clean or replace.	
	Defective pressure regulating valve																									Clean, adjust or replace.	
	Insufficient lubricating oil level		○																							Add proper lubricating oil. (See 2.2.1-3) in Chapter2.)	
Fuel system	Too early timing of fuel injection pump									○	○	○														Check and adjust. (See 2.2.7-4) in Chapter2.)	
	Too late timing of fuel injection pump								○	○	○	○													○	Check and adjust. (See 2.2.7-4) in Chapter2.)	
	Improper properties of fuel oil					○	○	○	○	○			○													Use proper fuel oil. (See 1.3.1 in Chapter1.)	
	Water entrance in fuel system	○			○								○	○												Perform draining from the fuel filter. (See 2.2.3 and 2.2.5 in Chapter2.)	
	Clogged fuel filter	○	○			○																				Clean or replace. (See 2.2.5 in Chapter2.)	
	Air entrance in fuel system	○	○			○																				Perform air bleeding. (See 2.2.3 in Chapter2.)	
	Clogged or cracked fuel pipe	○	○			○																				Clean or replace.	
	Insufficient fuel supply to fuel injection pump	○	○			○																				Check the fuel tank cock, fuel filter, fuel pipe, and fuel feed pump.	
	Uneven injection volume of fuel injection pump							○	○	○	○			○	○	○									○	Check and adjust.	
	Excessive fuel injection volume																									○	Check and adjust.
	Poor spray pattern from fuel injection nozzle							○	○	○	○															○	Check and adjust. (See 2.2.6 in Chapter2.)
	Priming failure	○																								Foreign matter trapped in the valve inside the priming pump. (Disassemble and clean.)	
	Clogged strainer at feed pump inlet							○																		Clean the strainer.	

Cause	Trouble symptom	Starting failure			Insufficient engine output			Poor exhaust color		High knocking sound during combustion	Abnormal engine sound	Uneven combustion sound	Hunting		Difficulty in returning to low speed	Excessive fuel consumption	Lubricating oil				Cooling water		Air intake		Corrective action			
		Engine does not start.	Engine starts but stops soon.		Exhaust color			During work					During idling	During work			Large engine vibration	Excessive consumption	Dilution by fuel oil	Mixture with water	Low L.O. pressure	Much blow-by gas	Overheat	Low water temperature		Pressure drop	Pressure rise	Exhaust temperature rise
			None	Little	Much	Ordinary	White	Black	White																			
Air/Exhaust Gas System	Clogged air filter			<input type="radio"/>			<input type="radio"/>	<input type="radio"/>			<input type="radio"/>													Clean. (See 2.2.4 in Chapter2.)				
	Engine used at high temperatures or at high altitude						<input type="radio"/>	<input type="radio"/>						<input type="radio"/>					<input type="radio"/>		<input type="radio"/>			Study output drop and load matching.				
	Clogged exhaust pipe						<input type="radio"/>	<input type="radio"/>			<input type="radio"/>												<input type="radio"/>	Clean.				
Electrical System	Starting motor defect	<input type="radio"/>																						Repair or replace. (See Chapter8.)				
	Alternator defect	<input type="radio"/>																						Repair or replace. (See Chapter9.)				
	Open-circuit in wiring	<input type="radio"/>																						Repair. (See Chapter10.)				
	Battery voltage drop	<input type="radio"/>																						Inspect and change the battery. (See 2.2.3 in Chapter2.)				

### 3.3 Troubleshooting by measuring Compression Pressure

Compression pressure drop is one of major causes of increasing blowby gas (lubricating oil contamination or increased lubricating oil consumption as a resultant phenomenon) or starting failure. The compression pressure is affected by the following factors:

- 1) Degree of clearance between piston and cylinder
- 2) Degree of clearance at intake/exhaust valve seat
- 3) Gas leak from nozzle gasket or cylinder head gasket

In other words, the pressure drops due to increased parts wear and reduced durability resulting from long use of the engine.

A pressure drop may also be caused by scratched cylinder or piston by dust entrance from the dirty air cleaner element or worn or broken piston ring. Measure the compression pressure to diagnose presence of any abnormality in the engine.

#### (1) Compression pressure measurement method

- 1) After warming up the engine, remove the fuel injection pipe and valves from the cylinder to be measured.
- 2) Crank the engine before installing the compression gage adapter.
  - \*1) Perform cranking with the stop handle at the stop position (no injection state).
  - \*2) See 12.2-18 in Chapter 12 for the compression gage and compression gage adapter.
- 3) Install the compression gage and compression gage adapter at the cylinder to be measured.
  - \*1) Never forget to install a gasket at the tip end of the adapter.
- 4) With the engine set to the same state as in 2)\*1), crank the engine by the starter motor until the compression gage reading is stabilized.

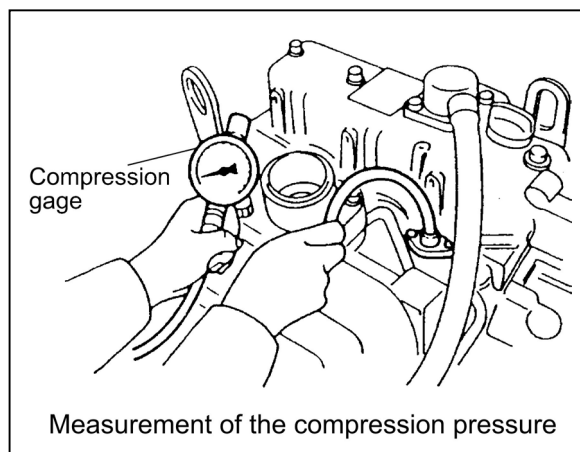

#### (2) Standard compression pressure

Engine compression pressure list (reference value)

Engine mode	Compression pressure at 250 min <sup>-1</sup> MPa (kgf/cm <sup>2</sup> )		Deviation among cylinders MPa (kgf/cm <sup>2</sup> )
	Standard	Limit	
3TNV82A	3.16±0.1 (31±1)	2.45±0.1 (25±1)	0.2~0.3 (2~3)
3/4TNV84	3.24±0.1 (33±1)	2.55±0.1 (26±1)	
3/4TNV84T	2.94±0.1 (30±1)	2.45±0.1 (25±1)	
TNV88~106(T)	3.43±0.1 (35±1)	2.75±0.1 (28±1)	

## (3) Engine speed and compression pressure (for reference)

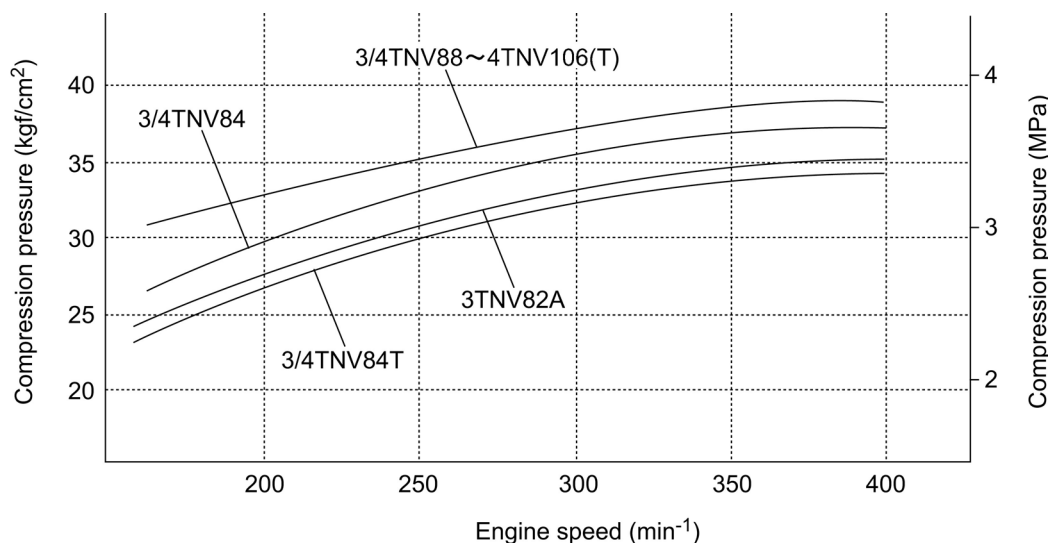

## (4) Measured value and troubleshooting

When the measured compression pressure is below the limit value, inspect each part by referring to the table below.

No.	Item	Cause	Corrective action
1	<ul style="list-style-type: none"> <li>● Air cleaner element</li> </ul>	<ul style="list-style-type: none"> <li>● Clogged element</li> <li>● Broken element</li> <li>● Defect at element seal portion</li> </ul>	<ul style="list-style-type: none"> <li>● Clean the element.</li> <li>● Replace the element.</li> </ul>
2	<ul style="list-style-type: none"> <li>● Valve clearance</li> </ul>	<ul style="list-style-type: none"> <li>● Excessive or no clearance</li> </ul>	<ul style="list-style-type: none"> <li>● Adjust the valve clearance. (See 3.5 in Chapter 3.)</li> </ul>
3	<ul style="list-style-type: none"> <li>● valve timing</li> </ul>	<ul style="list-style-type: none"> <li>● Incorrect valve clearance</li> </ul>	<ul style="list-style-type: none"> <li>● Adjust the valve clearance. (See 3.5 in Chapter 3.)</li> </ul>
4	<ul style="list-style-type: none"> <li>● Cylinder head gasket</li> </ul>	<ul style="list-style-type: none"> <li>● Gas leak from gasket</li> </ul>	<ul style="list-style-type: none"> <li>● Replace the gasket.</li> <li>● Retighten the cylinder head bolts to the specified torque. (See 4.2(2)12 in Chapter 4.)</li> </ul>
5	<ul style="list-style-type: none"> <li>● Intake/exhaust valve</li> <li>● Valve seat</li> </ul>	<ul style="list-style-type: none"> <li>● Gas leak due to worn valve seat or foreign matter trapping</li> <li>● Sticking valve</li> </ul>	<ul style="list-style-type: none"> <li>● Lap the valve seat. (See 4.2(6) in Chapter 4.)</li> <li>● Replace the intake/exhaust valve.</li> </ul>
6	<ul style="list-style-type: none"> <li>● Piston</li> <li>● Piston ring</li> <li>● Cylinder</li> </ul>	<ul style="list-style-type: none"> <li>● Gas leak due to scratching or wear</li> </ul>	<ul style="list-style-type: none"> <li>● Perform honing and use an oversized part. (See 4.4(5)-(5-1), (5-4) and (6) in Chapter 4.)</li> </ul>

## 4. Disassembly, Inspection and Reassembly of Engines

### 4.1 Complete disassembly and reassembly

#### 4.1.1 Introduction

Make preparation as follows before starting engine inspection and service:

- 1) Fix the engine on a horizontal base.

#### **⚠ CAUTION**

Be sure to fix the engine securely to prevent injury or damage to parts due to falling during the work.

- 2) Remove the coolant water hose, fuel oil pipe, wire harness, control wires etc. connecting the driven machine and engine, and drain coolant water, lubricating oil and fuel.
- 3) Clean soil, oil, dust, etc. from the engine by washing with solvent, air, steam, etc. Carefully operate so as to prevent any foreign matter from entering the engine.

#### **⚠ CAUTION**

Always wear glasses or other protectors when using compressed air or steam to prevent any foreign matter from getting in the eyes.

[NOTICE]

- Any part which is found defective as a result of inspection or any part whose measured value does not satisfy the standard or limit shall be replaced.
- Any part predicted to dissatisfy the standard or limit before the next service as estimated from the state of use should be replaced even when the measured value then satisfies the standard or limit.

### 4.1.2 Special service tools

#### (1) Special Tools

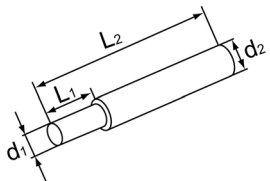
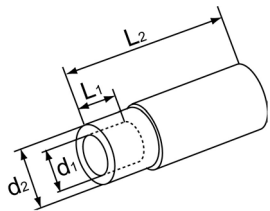
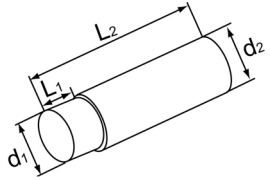
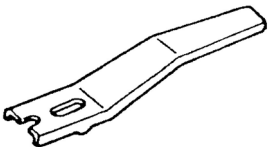
No.	Tool name	Applicable model and tool size	Illustration																																			
1	Valve guide tool (for extracting valve guide)	<table border="1"> <thead> <tr> <th colspan="5" style="text-align: right;">mm</th> </tr> <tr> <th>Model</th> <th>L1</th> <th>L2</th> <th>d1</th> <th>d2</th> </tr> </thead> <tbody> <tr> <td>3TNV82A 4TNV94L·98(T) 4TNV106(T)</td> <td>20</td> <td>75</td> <td>6.5</td> <td>10</td> </tr> <tr> <td>4TNV84 3TNV84(T) 3/4TNV88</td> <td>20</td> <td>75</td> <td>7.5</td> <td>11</td> </tr> <tr> <td>4TNV84T</td> <td>20</td> <td>75</td> <td>5.5</td> <td>9</td> </tr> </tbody> </table>	mm					Model	L1	L2	d1	d2	3TNV82A 4TNV94L·98(T) 4TNV106(T)	20	75	6.5	10	4TNV84 3TNV84(T) 3/4TNV88	20	75	7.5	11	4TNV84T	20	75	5.5	9											
		mm																																				
		Model	L1	L2	d1	d2																																
		3TNV82A 4TNV94L·98(T) 4TNV106(T)	20	75	6.5	10																																
4TNV84 3TNV84(T) 3/4TNV88	20	75	7.5	11																																		
4TNV84T	20	75	5.5	9																																		
※Locally manufactured																																						
2	Valve guide tool (for inserting valve guide)	<table border="1"> <thead> <tr> <th colspan="5" style="text-align: right;">mm</th> </tr> <tr> <th>Model</th> <th>L1</th> <th>L2</th> <th>d1</th> <th>d2</th> </tr> </thead> <tbody> <tr> <td>3TNV82A</td> <td>12</td> <td>60</td> <td>13</td> <td>19</td> </tr> <tr> <td>4TNV84 3TNV84(T) 3/4TNV88</td> <td>15</td> <td>65</td> <td>14</td> <td>20</td> </tr> <tr> <td>4TNV84T</td> <td>8.5</td> <td>60</td> <td>11</td> <td>17</td> </tr> <tr> <td>4TNV94L·98(T)</td> <td>7</td> <td>60</td> <td>13</td> <td>16</td> </tr> <tr> <td>4TNV106(T)</td> <td>13.6</td> <td>65</td> <td>13</td> <td>16</td> </tr> </tbody> </table>	mm					Model	L1	L2	d1	d2	3TNV82A	12	60	13	19	4TNV84 3TNV84(T) 3/4TNV88	15	65	14	20	4TNV84T	8.5	60	11	17	4TNV94L·98(T)	7	60	13	16	4TNV106(T)	13.6	65	13	16	
		mm																																				
		Model	L1	L2	d1	d2																																
		3TNV82A	12	60	13	19																																
		4TNV84 3TNV84(T) 3/4TNV88	15	65	14	20																																
		4TNV84T	8.5	60	11	17																																
4TNV94L·98(T)	7	60	13	16																																		
4TNV106(T)	13.6	65	13	16																																		
※Locally manufactured																																						
3	Connecting rod bushing replacer (for removal / installation of connecting rod bushing)	<table border="1"> <thead> <tr> <th colspan="5" style="text-align: right;">mm</th> </tr> <tr> <th>Model</th> <th>L1</th> <th>L2</th> <th>d1</th> <th>d2</th> </tr> </thead> <tbody> <tr> <td>3TNV82A</td> <td>25</td> <td>85</td> <td>23</td> <td>26</td> </tr> <tr> <td>TNV84~88</td> <td>20</td> <td>100</td> <td>26</td> <td>29</td> </tr> <tr> <td>4TNV94L·98</td> <td>20</td> <td>100</td> <td>30</td> <td>33</td> </tr> <tr> <td>4TNV106(T)</td> <td>20</td> <td>100</td> <td>37</td> <td>40</td> </tr> </tbody> </table>	mm					Model	L1	L2	d1	d2	3TNV82A	25	85	23	26	TNV84~88	20	100	26	29	4TNV94L·98	20	100	30	33	4TNV106(T)	20	100	37	40						
		mm																																				
		Model	L1	L2	d1	d2																																
		3TNV82A	25	85	23	26																																
		TNV84~88	20	100	26	29																																
4TNV94L·98	20	100	30	33																																		
4TNV106(T)	20	100	37	40																																		
Allowance: $d1_{-0.6}^{-0.3}$ $d2_{-0.6}^{-0.3}$																																						
※Locally manufactured																																						
4	Valve spring compressor (for removal / installation of valve spring)	yanmar code No. 129100-92630																																				



No.	Tool name	Applicable model and tool size	Illustration																																																								
5	Stem seal inserter (for inserting stem seal)	<table border="1"> <thead> <tr> <th colspan="8">mm</th> </tr> <tr> <th>Model</th> <th>d1</th> <th>d2</th> <th>d3</th> <th>L1</th> <th>L2</th> <th>L3</th> <th></th> </tr> </thead> <tbody> <tr> <td>3TNV82A</td> <td>15.2</td> <td>21</td> <td>12</td> <td>15.8</td> <td>65</td> <td>4</td> <td></td> </tr> <tr> <td>4TNV84 3TNV84(T) 4TNV88</td> <td>16.2</td> <td>22</td> <td>13.5</td> <td>18.8</td> <td>65</td> <td>4</td> <td></td> </tr> <tr> <td>4TNV84T</td> <td>12.9</td> <td>19</td> <td>11.5</td> <td>10.0</td> <td>65</td> <td>4</td> <td></td> </tr> <tr> <td>4TNE94L·98</td> <td>15.2</td> <td>21</td> <td>12</td> <td>11.8</td> <td>65</td> <td>4</td> <td></td> </tr> <tr> <td>4TNE106(T)</td> <td>15.2</td> <td>21</td> <td>12</td> <td>15.5</td> <td>65</td> <td>4</td> <td></td> </tr> </tbody> </table> <p>※Locally manufactured</p>	mm								Model	d1	d2	d3	L1	L2	L3		3TNV82A	15.2	21	12	15.8	65	4		4TNV84 3TNV84(T) 4TNV88	16.2	22	13.5	18.8	65	4		4TNV84T	12.9	19	11.5	10.0	65	4		4TNE94L·98	15.2	21	12	11.8	65	4		4TNE106(T)	15.2	21	12	15.5	65	4		
		mm																																																									
		Model	d1	d2	d3	L1	L2	L3																																																			
		3TNV82A	15.2	21	12	15.8	65	4																																																			
		4TNV84 3TNV84(T) 4TNV88	16.2	22	13.5	18.8	65	4																																																			
		4TNV84T	12.9	19	11.5	10.0	65	4																																																			
		4TNE94L·98	15.2	21	12	11.8	65	4																																																			
4TNE106(T)	15.2	21	12	15.5	65	4																																																					
6	Filter wrench (for removal / installation of L.O. filter)	Available on the market																																																									
7	Camshaft bushing tool (for extracting camshaft bushing)	<table border="1"> <thead> <tr> <th colspan="5">mm</th> </tr> <tr> <th>Model</th> <th>L1</th> <th>L2</th> <th>d1</th> <th>d2</th> </tr> </thead> <tbody> <tr> <td>TNV82A~88</td> <td>18</td> <td>70</td> <td>45</td> <td>48</td> </tr> <tr> <td>4TNV94L·98</td> <td>18</td> <td>70</td> <td>50</td> <td>53</td> </tr> <tr> <td>4TNV106(T)</td> <td>18</td> <td>70</td> <td>58</td> <td>61</td> </tr> </tbody> </table> <p>Allowance: <math>d1_{-0.3}^{-0.6}</math> <math>d2_{-0.3}^{-0.6}</math></p> <p>※Locally manufactured</p>	mm					Model	L1	L2	d1	d2	TNV82A~88	18	70	45	48	4TNV94L·98	18	70	50	53	4TNV106(T)	18	70	58	61																																
		mm																																																									
		Model	L1	L2	d1	d2																																																					
		TNV82A~88	18	70	45	48																																																					
4TNV94L·98	18	70	50	53																																																							
4TNV106(T)	18	70	58	61																																																							
8	Flex-Hone (For re-honing of cylinder liner)	<table border="1"> <thead> <tr> <th>Model</th> <th>Parts No.</th> <th>Cylinder bore (mm)</th> </tr> </thead> <tbody> <tr> <td>TNV82A~</td> <td>129400-92420</td> <td>78~84</td> </tr> <tr> <td>TNV88~4TNV94L</td> <td>129400-92430</td> <td>83~95</td> </tr> <tr> <td>4TNV98</td> <td>129400-92440</td> <td>89~101</td> </tr> <tr> <td>4TNV106(T)</td> <td>129400-92450</td> <td>95~108</td> </tr> </tbody> </table>	Model	Parts No.	Cylinder bore (mm)	TNV82A~	129400-92420	78~84	TNV88~4TNV94L	129400-92430	83~95	4TNV98	129400-92440	89~101	4TNV106(T)	129400-92450	95~108																																										
		Model	Parts No.	Cylinder bore (mm)																																																							
		TNV82A~	129400-92420	78~84																																																							
		TNV88~4TNV94L	129400-92430	83~95																																																							
		4TNV98	129400-92440	89~101																																																							
4TNV106(T)	129400-92450	95~108																																																									
9	Piston insertion tool (for inserting piston)	Yanmar code No. 95550-002476 ※The above piston insertion tool is applicable to 60-125 mm diameter pistons.																																																									
10	Piston ring replacer (for removal / installation of piston ring)	Available on the market																																																									
11	Crankshaft pulley installing tool	Locally manufactured (for 4TNV94L) (Refer to 4.3.6 in detail)																																																									

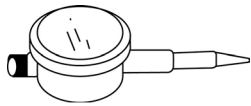
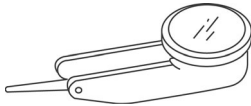
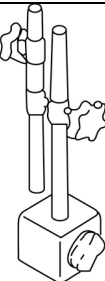
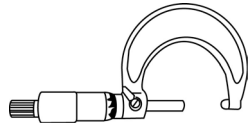
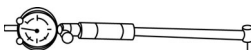
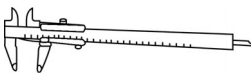
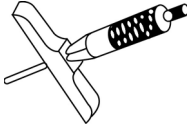
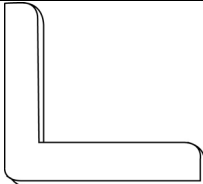

(2) Measuring instruments

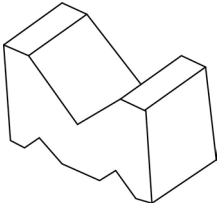
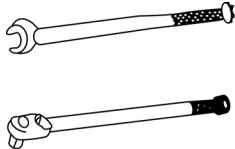
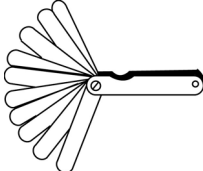
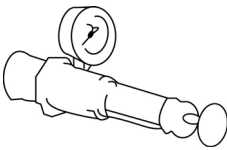
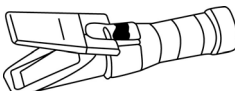
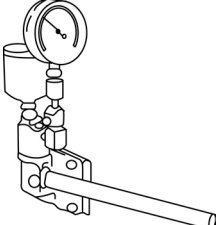
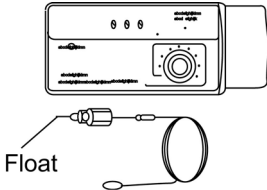
No.	Instrument name	Application	Illustration
1	Dial gage	Measurements of shaft bending, and strain and gap of surfaces	
2	Test indicator	Measurements of narrow or deep portions that cannot be measured by dial gage	
3	Magnetic stand	For holding the dial gage when measuring using a dial gage, standing angles adjustable	
4	Micrometer	For measuring the outside diameters of crankshaft, pistons, piston pins, etc.	
5	Cylinder gage	For measuring the inside diameters of cylinder liners, rod metal, etc.	
6	Calipers	For measuring outside diameters, depth, thickness and width	
7	Depth micrometer	For measuring of valve sink	
8	Square	For measuring valve spring inclination and straightness of parts	

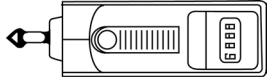
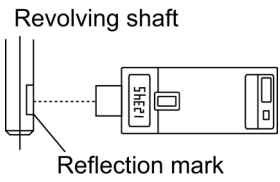
No.	Instrument name	Application	Illustration
9	V-block	For measuring shaft bend	
10	Torque wrench	For tightening nuts and bolts to the specified torque	
11	Thickness gage	For measuring gaps between ring and ring groove, and shaft joints during assembly	
12	Cap tester	For checking water leakage	
13	Battery coolant tester	For checking concentration of antifreeze and the battery electrolyte charge status	
14	Nozzle tester	For measuring injection spray pattern of fuel injection nozzle and injection pressure	
15	Digital thermometer	For measuring temperatures	

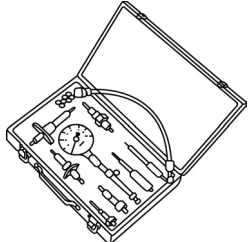
No.	Instrument name		Application	Illustration
16	Speedometer	Contact type	For measuring revolution by contacting the mortise in the revolving shaft	
		Photoelectric type	For measuring revolution by sensing the reflecting mark on the outer periphery of the revolving shaft	
17	Circuit tester		For measuring resistance, voltage and continuity of electrical circuits	
18	Compression gage kit		For measuring compression pressure Yanmar code No. TOL-97190080	

### 4.1.3 Complete disassembly

Peripheral parts such as air cleaner, muffler and radiator differ in installation and types for each application. Therefore, description in this Chapter is started with the steps to be taken just after the peripheral parts have been removed.

Step	Removal Parts	Remarks
1	<ol style="list-style-type: none"> <li>1) Thoroughly remove sand, dust, dirt and soil from the surface of the engine.</li> <li>2) Drain coolant water and lubricating oil from the engine.</li> </ol>	
2	<ol style="list-style-type: none"> <li>1) Remove turbocharger and exhaust manifold.</li> <li>2) Remove intake manifold and surge tank.</li> </ol>	
3	<ol style="list-style-type: none"> <li>1) Close the fuel cock valve of the fuel tank.</li> <li>2) Remove high-pressure fuel pipe.</li> <li>3) Remove fuel return pipe.</li> <li>4) Loosen the tightening nut on fuel injection nozzle retainer and extract the retainer and fuel injection nozzle.</li> </ol> <p>*) Fuel injection nozzle for Indirect injection system is screwed type.</p>	<ol style="list-style-type: none"> <li>1) If nozzle seat is left on the cylinder head, remove the cylinder head before extracting nozzle seat.</li> <li>2) To prevent dust from entering fuel injection nozzle, fuel injection pump and high-pressure fuel pipe, seal their respective threads with a tape or the like.</li> <li>3) Whenever extracting fuel injection nozzle, replace nozzle protector with a new one.</li> </ol>
4	<ol style="list-style-type: none"> <li>1) Remove rocker arm cover assembly.</li> </ol>	
5	<ol style="list-style-type: none"> <li>1) Remove valve rocker arm shaft assembly.</li> <li>2) Remove push rod.</li> </ol>	<ol style="list-style-type: none"> <li>1) Attach a tag to push rod for each cylinder No. to put the push rod in order.</li> <li>2) Remove valve cap from the intake/exhaust valve head.</li> <li>3) Note that tappet of the indirect injection system can be removed at the same time when push rod is extracted.</li> <li>4) Attach a tag to tappet for each cylinder No. to put the tappet in order.</li> </ol>
6	<ol style="list-style-type: none"> <li>1) Remove fan mounting bolt, and then remove fan.</li> <li>2) Loosen adjusting bolt for the V-belt adjuster, and then remove V-belt.</li> <li>3) Remove alternator.</li> <li>4) Remove the spacer for cooling fan and V-pulley.</li> </ol>	<ol style="list-style-type: none"> <li>1) Never turn down alternator vigorously toward the cylinder block. Otherwise, your finger may be nipped and alternator broken.</li> </ol>
7	<ol style="list-style-type: none"> <li>1) Remove lubricating oil filter assembly.</li> <li>2) Extract dipstick form the oil dip-stick hole.</li> </ol>	
8	<ol style="list-style-type: none"> <li>1) Disconnect fuel return pipes to.</li> <li>2) Remove fuel filter.</li> </ol>	

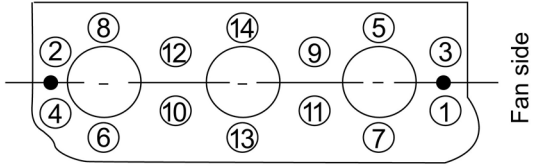
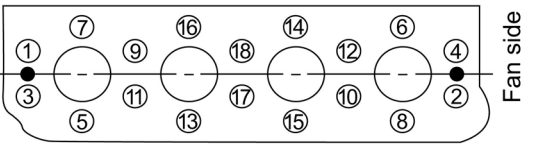
Step	Removal Parts	Remarks
9	1) Disconnect coolant water pipe from the cooling water pump. 2) Remove thermostat assembly. 3) Remove cooling water pump.	
10	1) Remove cylinder head tightening bolt. 2) Remove cylinder head assembly. 3) Remove cylinder head gasket.	1) Lay a cardboard or the like on the floor and place cylinder head assembly on it so as not to damage the combustion surface. 2) Order of loosening the cylinder head tightening bolts.  Disassembly Camshaft side  <p style="text-align: center;">Head bolt disassembly order 3 cylinder head</p> Disassembly Camshaft side  <p style="text-align: center;">Head bolt disassembly order 4 cylinder head</p> 3) To remove the intake/exhaust valves from cylinder head assembly, take the following steps. a) Using a valve spring compressor (see Chapter 5, 5-1), compress valve spring and remove valve cotter. b) Remove valve retainer and valve spring. c) Remove intake valve and exhaust valve.
11	1) Remove crankshaft V-pulley clamping bolt. 2) Using a puller, extract crankshaft V-pulley.	1) Extract crankshaft V-pulley by hitting the bolt of the puller using a plastic hammer or the like.
12	1) Remove oil pan mounting bolt under gear case. 2) Remove gear case mounting bolt. 3) Remove gear case.	1) Never fail to remove stiffener bolt at the center of the gear case. 2) When removing the gear case, carefully protect oil seal from damage.
13	1) Remove the nut from fuel injection pump drive gear. Extract fuel injection pump drive gear using a puller.	1) Before removing fuel injection pump, make sure of the position of the arrow of the pump body for adjusting fuel injection timing as well as the position of the scribed line of the gear case flange. (Applies only to direct injection system.)

Step	Removal Parts	Remarks
14	1) Remove lubricating oil pump.	
15	1) Remove starting motor from flywheel housing sing.	
16	1) Remove flywheel mounting bolt. 2) Remove flywheel.	1) Carefully protect the ring gear from damage mage.
17	1) Remove flywheel housing. 2) Remove oil seal case with a screwdriver or the like by utilizing grooves on both sides of oil seal case.	1) Carefully protect the oil seal from damage.
18	1) Remove oil pan and spacer.	1) Put the cylinder block with the attaching surface of the cylinder head facing down. 2) Carefully protect the combustion surface of the cylinder block from damage. 3) For indirect injection system, be careful to the possibility of the tapped to drop off when the cylinder block is turned upside down, because the tappet is cylindrical in shape.
19	1) Remove idle gear shaft, and then remove idle gear. 2) Remove mounting bolt of thrust bearing through the hole of the camshaft gear. Remove camshaft assembly.	1) Turn the cylinder block aside and carefully prevent tappet from jamming on the cam. 2) Preheat camshaft gear and camshaft assembly to 180°~200° which are shrink fitted, before removing them.
20	1) Remove gear case flange.	
21	1) Remove lubricating oil strainer.	
22	1) Remove crankpin side cap of the connecting rod. While turning crankshaft, place piston in the bottom dead center (BDC).	1) Before extracting piston, remove carbon deposits from the upper wall of the cylinder using fine sandpaper, while taking care not to damage the inner surface of the cylinder. 2) Make sure than cap No. of connecting rod agrees with cylinder No. 3) Take care not to let crankpin metal fall when removing connecting rod crankpin side cap.

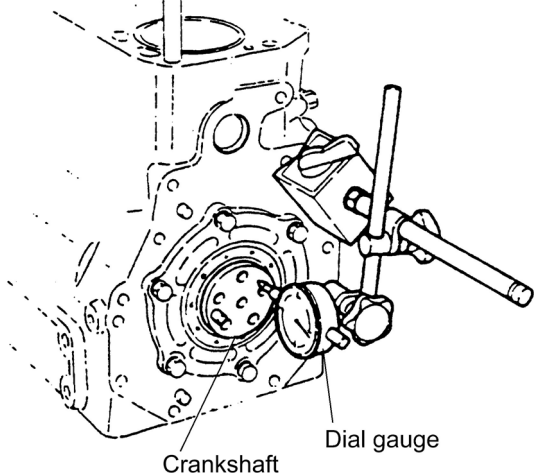
Step	Removal Parts	Remarks
23	<p>1) Remove main bearing cap bolt. While shaking main bearing cap, remove main bearing cap together with lower main bearing metal.</p> <p>2) Extract crankshaft, taking care not to damage it.</p> <p>3) Remove upper main bearing metal.</p>	<p>1) Before extracting crankshaft, measure the side gap around it.</p>  <p>Apply a dial gauge to the end of crankshaft. Force the crankshaft on both sides in the axial direction to measure the thrust gap. Alternatively, insert a thickness gauge directly between the base thrust metal and the thrust surface of the crankshaft to measure the gap. If the limit size is exceeded, replace the thrust metal with a new one.</p> <p>Thrust gap (All models)</p> <p>2) Notice on the removal of thrust metal.</p> <p>a) When removing thrust metal, ascertain the position and direction where thrust metal is installed in relation to the cap.</p> <p>b) Make sure that the thrust metal groove is outward in relation to the cap.</p>
24	<p>1) Remove piston and connecting rod assembly.</p>	<p>1) To selectively remove a desired piston and connecting rod assembly without extracting crankshaft, take the steps itemized below:</p> <p>a) Remove carbon deposits from the upper wall of the cylinder using fine sandpaper, taking care not to damage the inner surface of the cylinder.</p> <p>b) While turning the crankshaft, with the connecting rod cap removed, raise the piston up to the top dead center (TDC).</p> <p>c) Extract the piston/connecting rod assembly while tapping the connecting rod at the large end with the handle of a plastic hammer or the like.</p>
25	<p>2) Remove tappet.</p>	

#### **4.1.4 Precautions before and during reassembly**

To reassemble engine components, reverse the procedure of disassembly. However, follow the precautions below and the precautions from in chapter 4 to in chapter 7 particularly before and during reassembly.

##### **(1) Cleaning the component**

Use particular care to clean the cylinder block, cylinder head, crankshaft, and camshaft. Ensure that they are free from chips, dust, sand, and other foreign matter.

##### **(2) Parts to be replaced during reassembly**

Be sure to replace the following parts with new ones during assembly.

- Valve stem seal
- Head gasket packing
- Nozzle protector and nozzle seat of the fuel injection valve
- Various copper packing, O-rings and gasket packing.

#### **4.1.5 Adjusting operation**

Make sure to perform adjusting operation after completing reassembly. Refer to section 2.5 in chapter 2 for the operation procedure.



## 4.2 Cylinder Head: Disassembly, Inspection and Reassembly

### 4.2.1 Components (2-valve cylinder head)

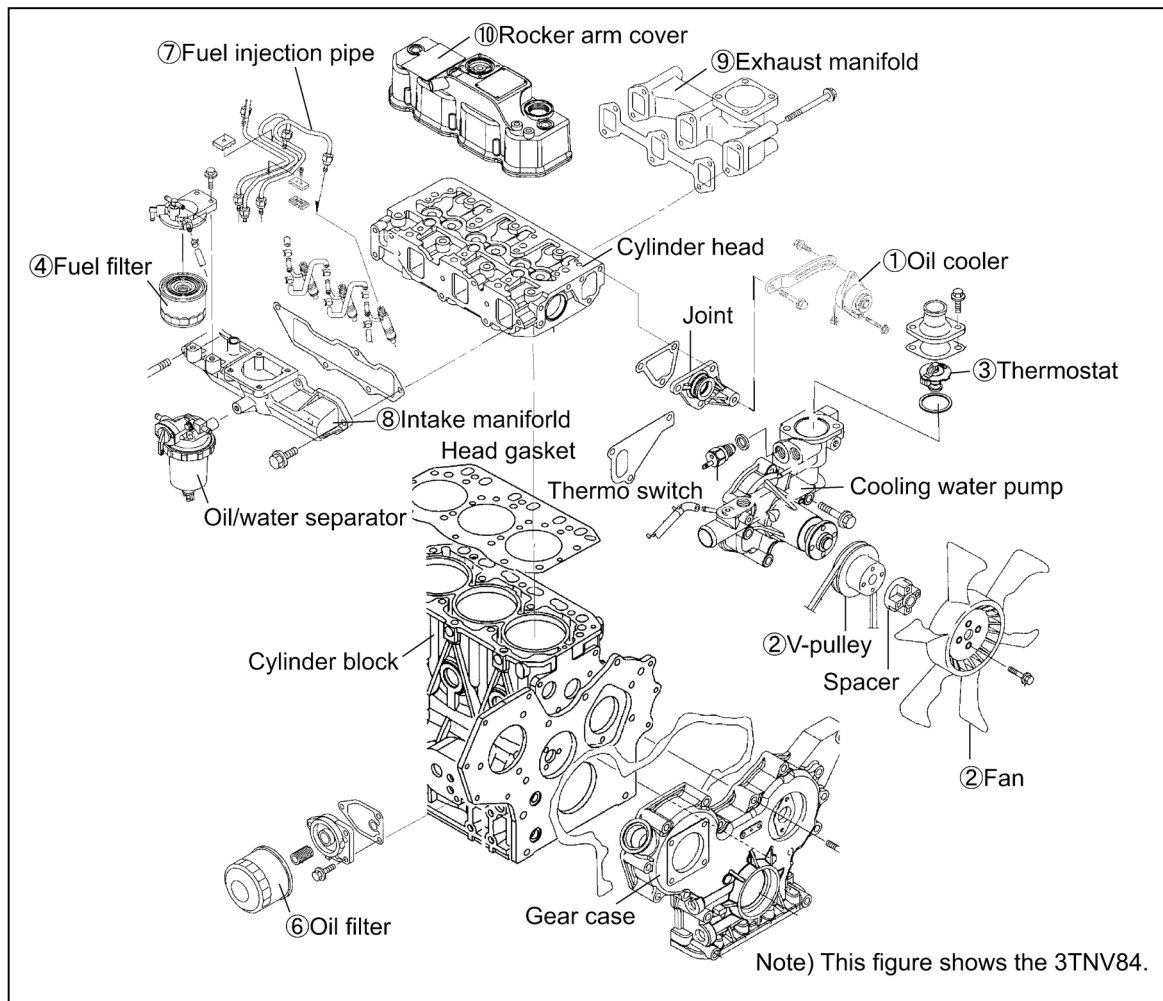

### 4.2.2 Disassembly procedure:

Disassemble in the order of the numbers shown in the illustration.

- 1) Remove the alternator assy. (Point1)
- 2) Remove the fan, pulley and V belt.
- 3) Remove the thermostat case. (Point2)
- 4) Remove the fuel filter and fuel oil piping. (Point3)
- 5) Remove the oil level gage assy.
- 6) Remove the oil filter. (Point4)
- 7) Remove the fuel injection pipes. (Point5)
- 8) Remove the intake manifold assy.
- 9) Remove the exhaust manifold assy.
- 10) Remove the rocker arm cover Assy.
- 11) Remove the rocker shaft assy, push rods and valve caps. (Point6)
- 12) Remove the cylinder head assy and head gasket. (Point7)
- 13) Remove the fuel injection valves and fuel return pipe. (Point8)
- 14) Remove the intake/exhaust valves, stem seals and valve springs. (Point9)
- 15) Remove the rocker arms from the rocker shaft.

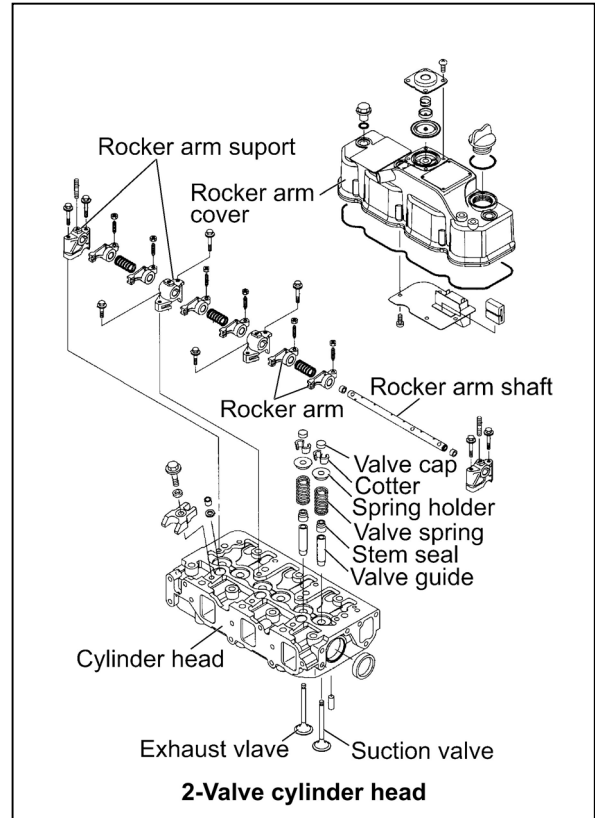
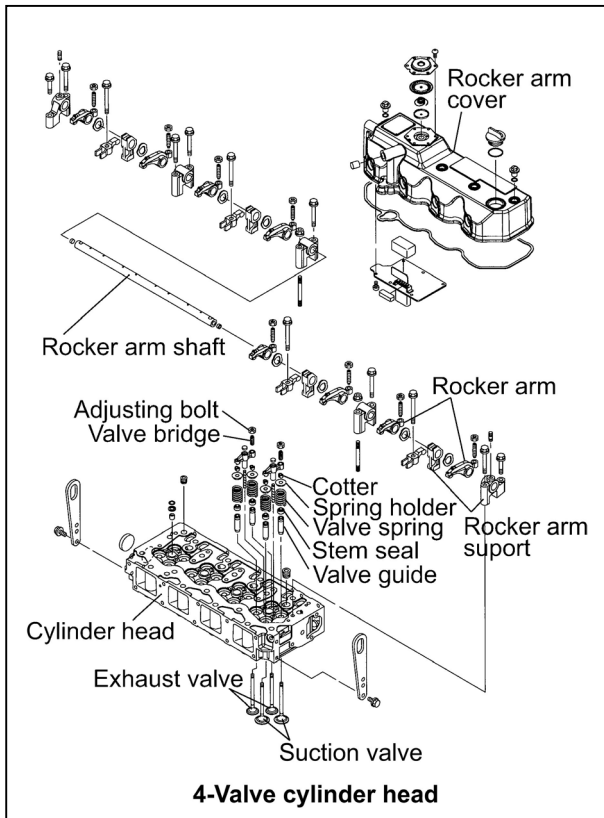

### 4.2.3 Reassembly procedure:

Reverse order of the disassembly procedure.

## 4.2.4 Servicing points

### Point1

[Disassemble]

- Loosen the mounting bolt while supporting the alternator.

### ⚠ CAUTION

Do not tilt the alternator toward the cylinder block in haste since it may damage the alternator or pinch a finger.

[Reassemble]

- The belt deflection shall be checked according to 2.2.2. in Chapter2.

[Reassemble]

- Replace the belt with a new one if cracked, worn or damaged.
- Carefully prevent the belt from being smeared with oil or grease.

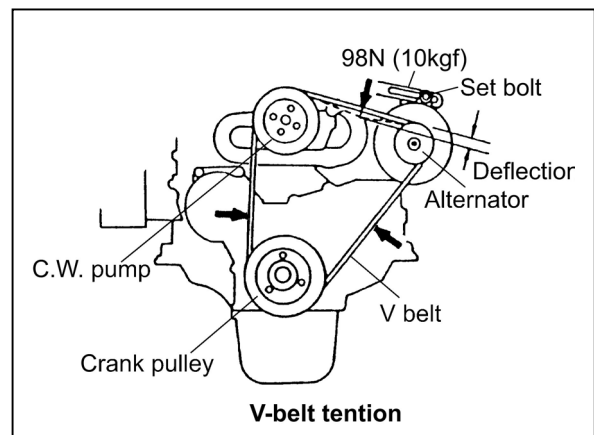
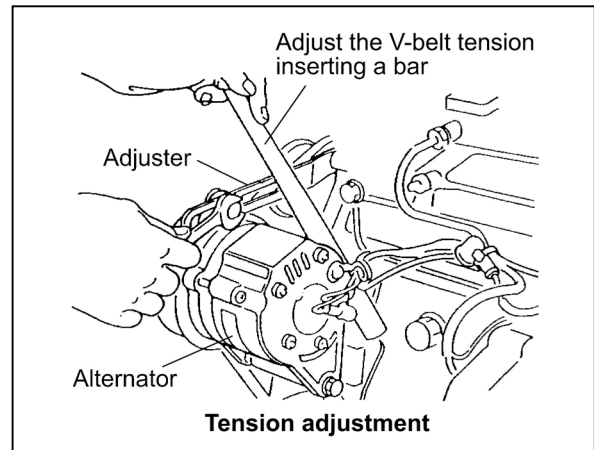

### Point2

[Reassemble]

- Check the thermostat function. (See3.9 in Chapter 3 for the check procedure.)

### Pont3

[Reassemble]

- Replace the fuel filter element with a new one.

[Disassemble]

- Cover the fuel pipe opening with tape to prevent intrusion of foreign matters.

### Point4

[Reassemble]

- Replace the oil filter with a new one.
- After fully tightening the filter manually, retighten it with a filter wrench (see 11.1-6 in Chapter 11) by 3/4 turn.

### Point5

[Disassemble]

- Cover the fuel injection pipe and pump inlets and outlets with tape or the like to prevent intrusion of foreign matters.

**Point6**

1) Removing pipe seals of 4 valve head.  
[Disassemble]

- Take off a rocker arm cover in case of 4 valve head after removing fuel injection pipes and pipe seals.

[NOTICE]

Attention is necessary because a fuel nozzle is caught in a pipe seal and the pipe seal is damaged when a rocker arm cover is lifted with a pipe seal sticking to the rocker arm cover.

- Insert a minus driver in the slit part of the rocker arm cover, and remove it when removing a pipe seal.

[Reassemble]

- Replace the used pipe seal with a new one when removing a pipe seal.

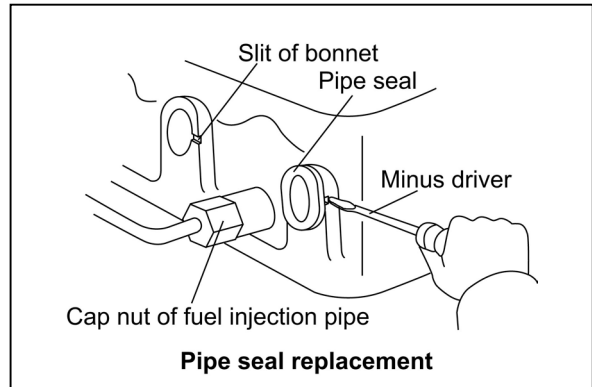
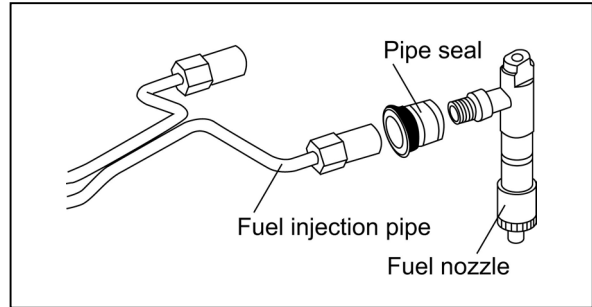

2) Breather system (A reductor to intake air system of blowby gas)

Emitting blowby gas is harmful to natural environment. Therefore blowby gas reductor is adopted to TNV series naturally- aspirated engines as breather system (Turbocharged engines emitblowby gas).

The system of model 3/4TNV84 is shown as a representative of that breather system in the right figure. Some of the combustion gas passes through the clearance between the cylinder and the piston, piston ring, and flows to the crankcase. This is said as blowby gas. While it passes into the cylinder head and the rocker arm cover, the blowby gas mixes with splash oil, and becomes oil mist-blowby gas mixes with splash oil, and becomes oil mist-blowby gas ith passing through the baffle plate inside a rocker arm cover. And it passes through a diaphragm assy, and a intake manifold, and is reduced in the combustion chamber. Pressure inside a crankcase is controlled by the function of the diaphragm assy, and suitable amount of blowby gas is reduced in intake air system.

[Disassemble]

When a rocker arm cover is taken off, check whether oil or the like enter the diaphragm space from a small hole on the side of a diaphragm cover or not without disassembling the diaphragm.

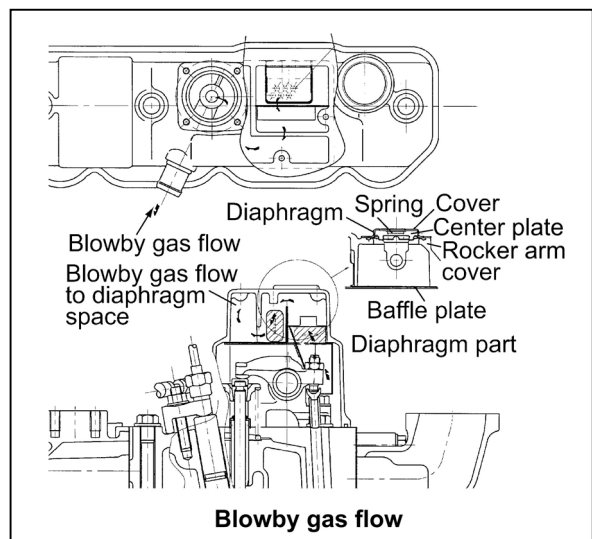
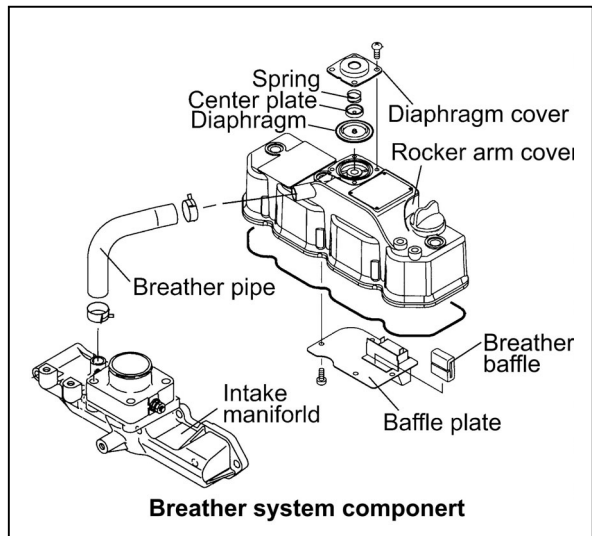

[NOTICE]

1) When a diaphragm is damaged, pressure control inside the crankcase becomes insufficient, and troubles occur. When the internal pressure of the crankcase decreases too much due to the damage of a spring, much blowby gas containing oil is reduced in intake air system, and it may cause the combustion defect by the early dirt of the intake valve or the urgent rotation of the engine by the oil burning.

When pressure progresses in the crank case too much due to the wrong operation of the diaphragm and so on, it is considered that oil leakage from the joint of a oil pan, a oil seal and so on will occur. When a diaphragm is damaged, blowby is discharged from the breathing hole on the side of diaphragm cover, and not reduced in the intake manifold. Therefore, be careful of the diaphragm trouble.

2) At lubricating oil replacement or lube oil supply

The amount of lubricating oil isn't to be beyond the standard upper limit (in the engine horizontality, the upper limit mark of the dip stick). Since the blowby gas reductor is adopted, be careful that the amount of oil mist may be inducted in the combustion chamber and the oil hammer sometimes may occur, when the lubricating oil quantity is beyond the upper limit or an engine is operated beyond the allowable maximum angle of an engine.

[Reassembly]

Replace the diaphragm with new one, when it is damaged.

**Point7**

[Disassemble]

- Keep the removed push rods by attaching tags showing corresponding cylinder Nos.

[Reassemble]

- Always apply oil to the contact portions of the push rods and clearance adjusting screws.

**Point8**

[Disassemble]

- Loosen the cylinder head bolts in two steps in the illustrated order.
- Place the cylinder head assy on a paper board to prevent the combustion face from any damage.

[Reassemble]

- Remove the head gasket with a new one.
- Uniformly install the head bolts manually after applying oil on the threaded and seat portions
- They shall be tightened in two steps in the reverse of the order for disassembly.
- Tightening torque

	Nm(kgf·m)	
	TNV82A	TNV84-88
First step	30.0~34.0 (3.1~3.5)	41.1~46.9 (4.2~4.8)
Second step	61.7~65.7 (6.3~6.7)	85.3~91.1 (8.7~9.3)
	4TNV94L/98	4TNV106(T)
First step	49.0~58.8 (5.0~6.0)	88.3~98.1 (9.0~10.0)
Second step	103.1~112.9 (10.5~11.5)	188.0~197.8 (19.0~20.0)

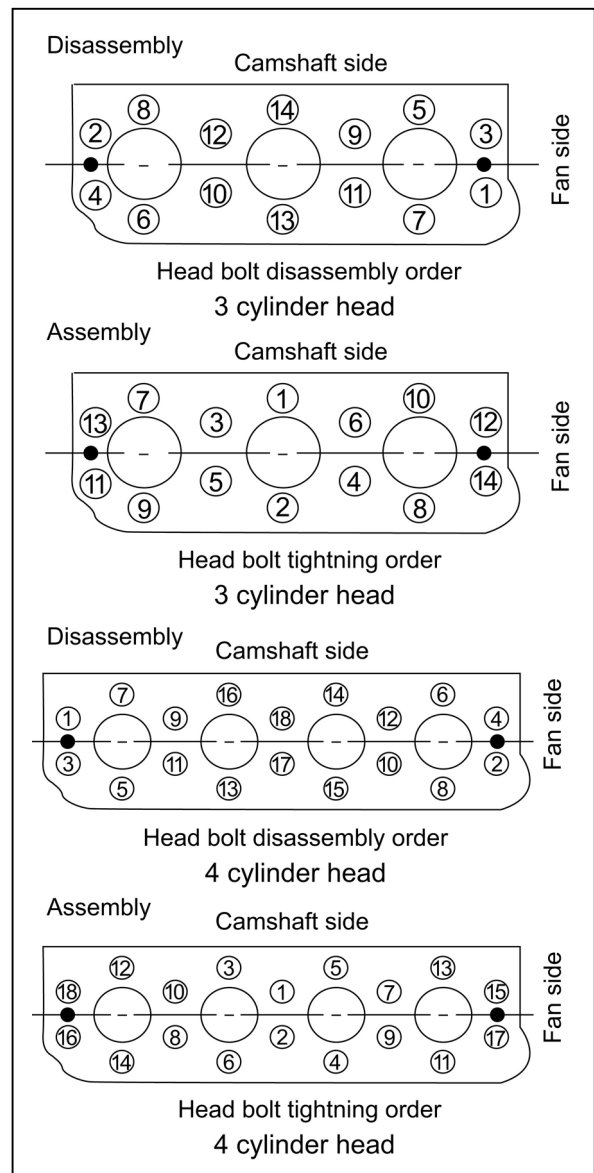

**Point9**

[Disassemble]

- Carefully remove the fuel injection valve so as not to leave the top end protector from being left inside the cylinder.

[Reassemble]

- Replace the fuel injection valve protector with a new one.

**Point10**

[Disassemble]

- When removing each intake/exhaust valve from the cylinder head, use a valve spring compressor (see 11.1-4 in Chapter 11) and compress the valve spring and remove the valve cotter.)
- Keep each removed intake/exhaust valve after attaching a tag showing the corresponding cylinder No.
- If cotter burr is seen at the shaft of each intake/exhaust valve stem, remove it with an oilstone and extract the valve from the cylinder head.

[Reassemble]

- Replace the stem seal with a new one when an intake/exhaust valve is disassembled.
- Carefully install each valve after oil application so as not to damage the stem seal.
- Different stem seals are provided for the intake and exhaust valves. Do not confuse them since those for exhaust valves are marked with yellow paint.
- After assembling the intake/exhaust valve, stem seal, valve spring, seat, and cotter, tap the head of the valve stem lightly for settling.
- Do not forget to install the valve cap.

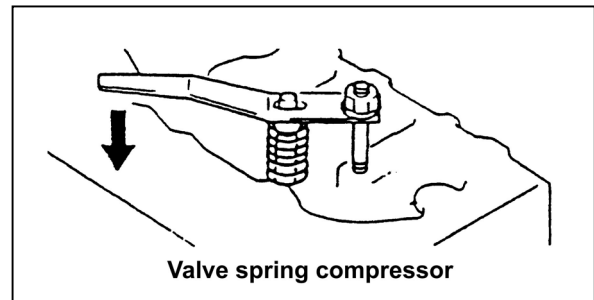

### 4.2.5 Parts Inspection and measurement

**(1) Cylinder head**

Clean the cylinder head, mainly the combustion surface, valve seats and intake/exhaust ports, remove carbon deposit and bonding agent, and check the surface state.

**(a) Appearance check**

Check mainly discoloration and crack. If crack is suspected, perform color check.

**(b) Combustion surface distortion**

Apply a straight-edge in two diagonal directions and on four sides of the cylinder head, and measure distortion with a thickness gage.

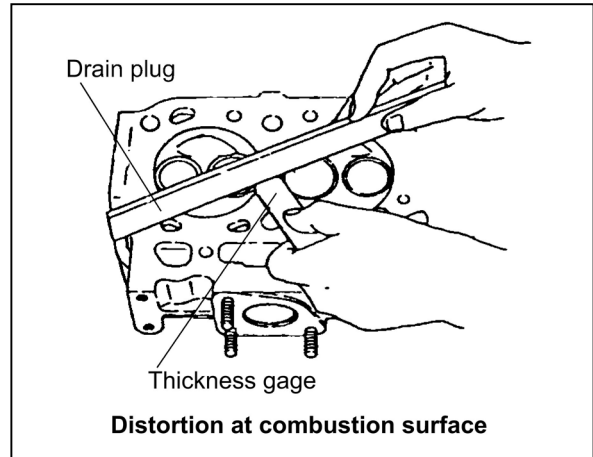

		mm	
		Standard	Limit
Distortion		0.05 or less	0.15

**(c) Valve sink**

Measure with the valve inserted to the cylinder head.

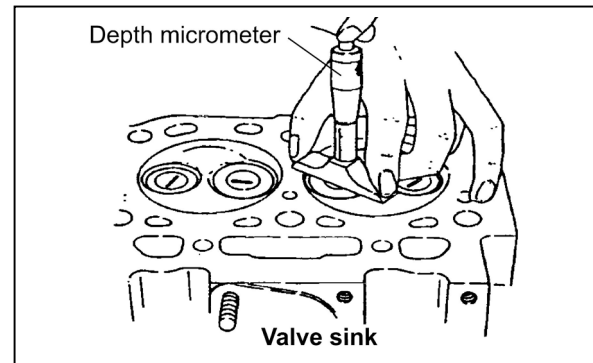

		mm	
		Standard	Limit
3TNV82A (2-valve head)	Intake	0.35~0.55	0.8
	Exhaust	0.30~0.50	0.8
4TNV84 3TNV84(T) 3/4TNV88 (2-valve head)	Intake	0.30~0.50	0.8
	Exhaust	0.30~0.50	0.8
4TNV84T 4TNV94/98(T) (4-valve head)	Intake	0.36~0.56	0.8
	Exhaust	0.35~0.55	0.8
4TNV106(T) (4-valve head)	Intake	0.5~0.7	1.0
	Exhaust	0.7~0.9	1.2

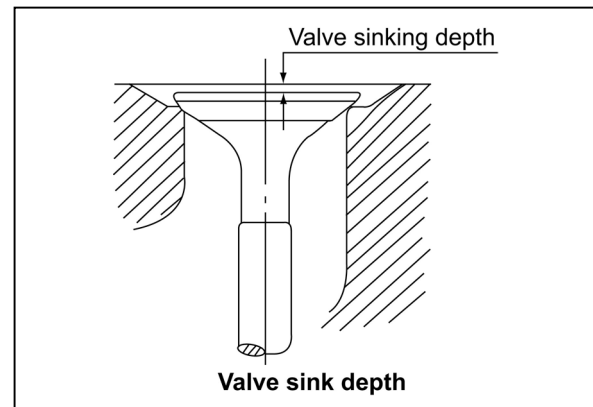

**(d) Seat contact**

Apply a thin coat of minium on the valve seat. Insert the valve in the cylinder and push it against the seat to check seat contact.

Standard: Continuous contact all around

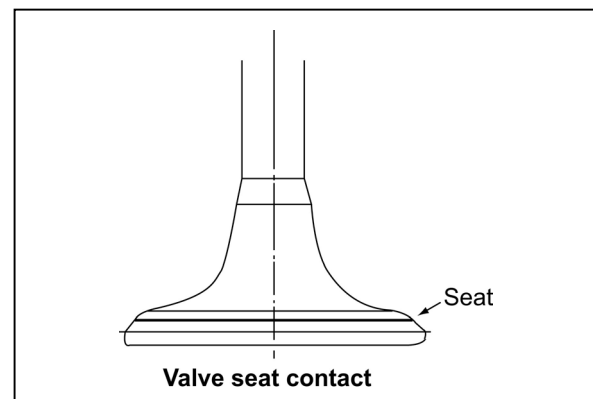

(2) Valve guide

Mainly check damage and wear on the inside wall.  
Apply the service part code when replacing a part.

Model		Service part code
3TNV82A (2-valve)	Suction	124060-11800
	Exhaust	119802-11810
4TNV84 3TNV84(T) 3/4TNV88 (2-valve)	Suction	120130-11860
	Exhaust	129150-11810
4TNV84T (4-valve)	Suc./Exh.	119717-11800
4TNV94L 4TNV98(T) (4-valve)	Suc./Exh.	129907-11800
4TNV106(T) (4-valve)	Suction	123907-11800
	Exhaust	123907-11810

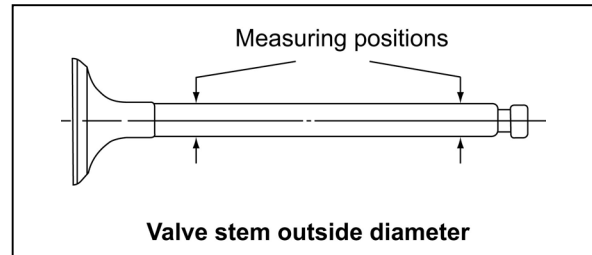
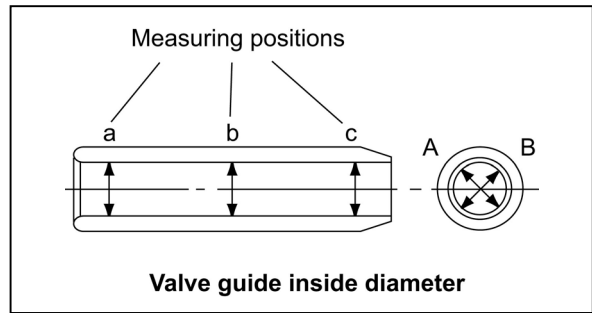

**Valve stem clearance**

Model	Part name	Place	Standard	Limit
3TNV82A (2-valve head)	Intake valve	Guide I.D.	7.000~7.015	7.08
		Stem O.D.	6.945~6.960	6.90
		Clearance	0.040~0.070	0.18
	Exhaust valve	Guide I.D.	7.000~7.015	7.08
		Stem O.D.	6.940~6.955	6.90
		Clearance	0.045~0.075	0.18
4TNV84 3TNV84(T) 3/4TNV88 (2-valve head)	Intake valve	Guide I.D.	8.010~8.025	8.10
		Stem O.D.	7.955~7.975	7.90
		Clearance	0.035~0.070	0.18
	Exhaust valve	Guide I.D.	8.015~8.030	8.10
		Stem O.D.	7.955~7.970	7.90
		Clearance	0.045~0.075	0.18
4TNV84T (4-valve head)	Intake valve	Guide I.D.	6.000~6.015	6.08
		Stem O.D.	5.960~5.975	5.90
		Clearance	0.025~0.055	0.15
	Exhaust valve	Guide I.D.	6.000~6.015	6.08
		Stem O.D.	5.945~5.960	5.90
		Clearance	0.040~0.070	0.17
4TNV94L 4TNV98(T) (4-valve head)	Intake valve	Guide I.D.	7.000~7.015	7.08
		Stem O.D.	6.945~6.960	6.90
		Clearance	0.040~0.070	0.17
	Exhaust valve	Guide I.D.	7.000~7.015	7.08
		Stem O.D.	6.940~6.955	6.90
		Clearance	0.045~0.075	0.17
4TNV106(T) (4-valve head)	Intake valve	Guide I.D.	7.008~7.020	7.08
		Stem O.D.	6.960~6.975	6.92
		Clearance	0.033~0.060	0.16
	Exhaust valve	Guide I.D.	7.008~7.020	7.08
		Stem O.D.	6.945~6.960	6.90
		Clearance	0.048~0.075	0.18



(3) Intake/exhaust valve

Mainly clean and check damage and wear at the valve stem and seat.

- (a) Seat contact: See (1)-(d) above.
- (b) Stem outside diameter: See (2) above.
- (c) Valve head thickness

Model	Part	Standard	Limit
TNV82A~88	Intake	1.34	0.50
	Exhaust	1.45	0.50
4TNE94·95	Intake	1.71	1.00
	Exhaust	1.65	1.00
4TNE106(T)	Intake	2.00	1.30
	Exhaust	2.00	1.30

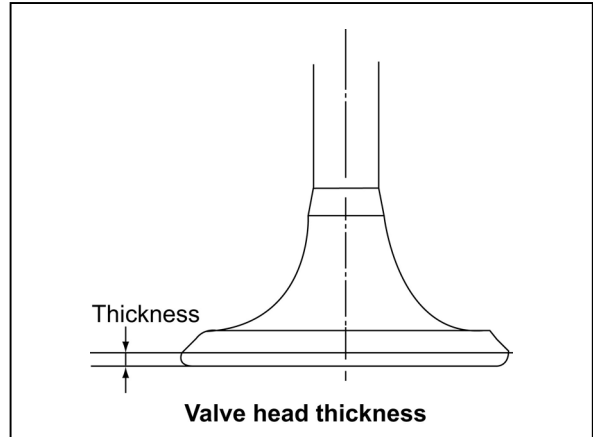

(d) Valve stem bend

Limit	mm
0.01	

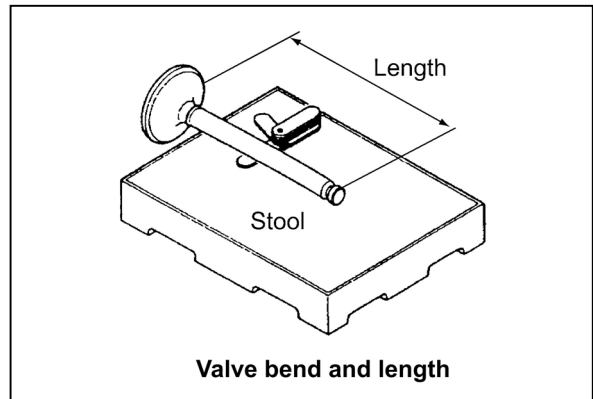

(e) Overall length

		Standard	Limit
3TNV82A	Intake/Exhaust	?	
TNV84~88	Intake/Exhaust		
4TNV94·98	Intake/Exhaust	115	114.5
4TNV106(T)	Intake/Exhaust	126	125.5

(4) Valve spring

Mainly inspect damage and corrosion.

	Free length standard	Inclination limit
3TNV82A	44.4?	1.2
TNV84~88	42.0?	
4TNV94·98	47.5	1.2
4TNV106(T)	50.6	

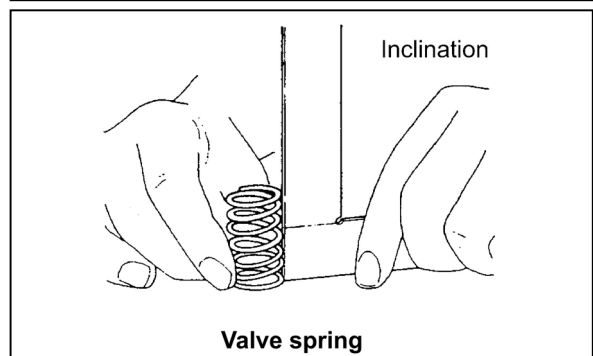
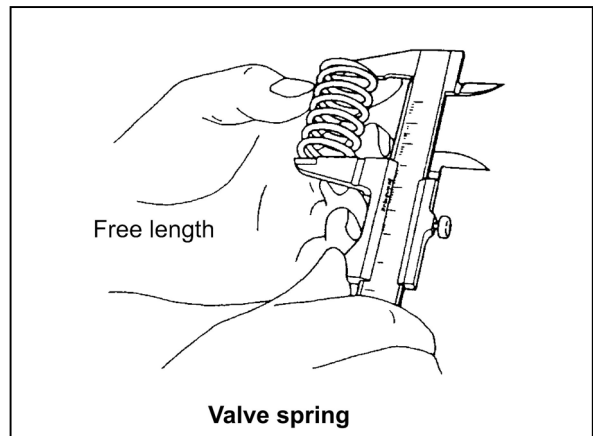

**(5) Valve rocker arm**

Mainly inspect valve head cap contact surface, inside surface defects and wear.

Slight surface defects shall be corrected with an oilstone.

mm			
Model	Items	Standard	Limit
TNV82A~88	Arm hole diameter	16.00~16.02	16.07
	Shaft O.D.	15.97~15.98	15.94
	Clearance	0.016~0.054	0.13
4TNV94/98(T) 4TNV106(T)	Arm hole diameter	18.50~18.52	18.57
	Shaft O.D.	18.47~18.49	18.44
	Clearance	0.01~0.05	0.13

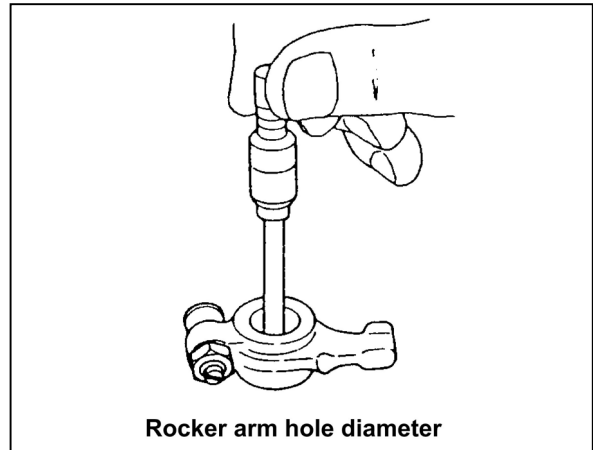

**(6) Rocker arm shaft**

Mainly inspect seizure and wear at the surface in sliding contact with the arm. The rocker shaft diameter shall be as specified in (5.5) above.

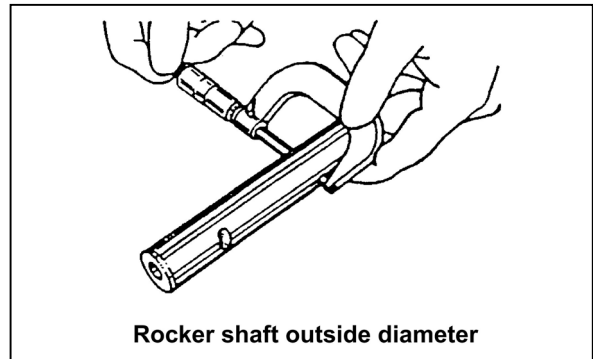

**(7) Push rod**

Mainly inspect the surface in contact with the tappet and adjusting screw. Slight defects shall be corrected with an oilstone.

Bend limit	0.03mm or less
------------	----------------

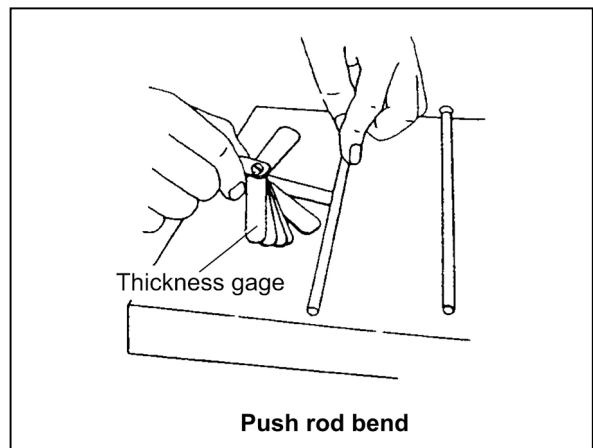

**(8) Valve clearance adjusting screw**

Mainly inspect the surface in contact with the push rod.

Slight defects shall be corrected with an oilstone.

**(9) Rocker arm spring**

Mainly inspect surface defects and corrosion.

### 4.2.6 Valve seat correction

[NOTICE]

Always check the oil clearance between the valve and valve guide before correcting the valve seat. If it exceeds the limit, replace the valve or valve guide first to make the clearance satisfy the standard. After correction, wash the valve and the cylinder head sufficiently with diesel oil to remove all grinding powder or compound.

- 1) If the seat surface is slightly roughened: perform **[A]** and **[B]** below.

**[A]:** Lap the valve and seat with a mixture of valve compound and engine oil.

**[B]:** Lap with engine oil only.

- 2) If the seat is heavily roughened but the width is almost normal, correct with a seat grinder or seat cutter first. Then perform lapping **[A]** and **[B]**.

	intake	Exhaust
Seat cutter angle	120	90

- 3) If the seat is heavily roughened and the width is much enlarged, grind the seat inner surface with a seat grinder whose center angle is  $40^\circ$ , then grind the seat outer surface with a grinder whose center angle is  $150^\circ$  to make the seat width match the standard. Then perform seat correction as described in 2), and then carry out lapping **[A]** and **[B]**.

Grinding wheel angle	$\theta_1$	$\theta_2$
	40	150

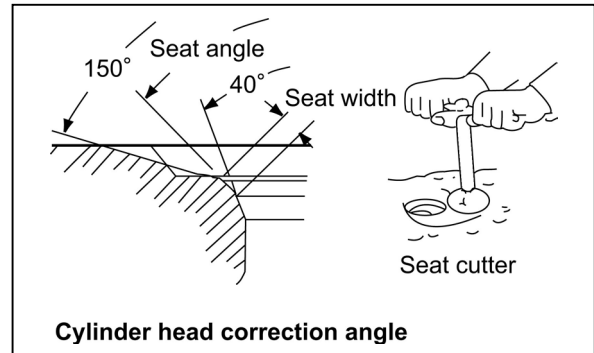

### 4.2.7 Valve guide replacement

- 1) Use a valve guide extraction tool(12.1-1 in Chapter 12) and extract the valve guide from the cylinder head.
- 2) Put liquid nitrogen or ether (or alcohol) with dry ice added in a container and put the valve guide for replacement in it for cooling. Then insert it in with a valve guide inserting tool (Refer to No.2 of 4.1.2 in Chapter 4).

**⚠ CAUTION**

Do not touch the cooled valve guide with bare hands to avoid skin damage.

- 3) Check the inside diameter and finish to the standard inside diameter as required with a reamer.
- 4) Check the projection from the cylinder head.

Model	Number of valves	Projection mm
3TNV82A	2 valves	11.7~12.0
4TNV84 3TNV84(T) 4TNV88		14.7~15.0
4TNV84T	4 valves	8.2~8.5
4TNV94L 4TNV98(T)		9.7~10.
4TNE106(T)		13.4~13.6

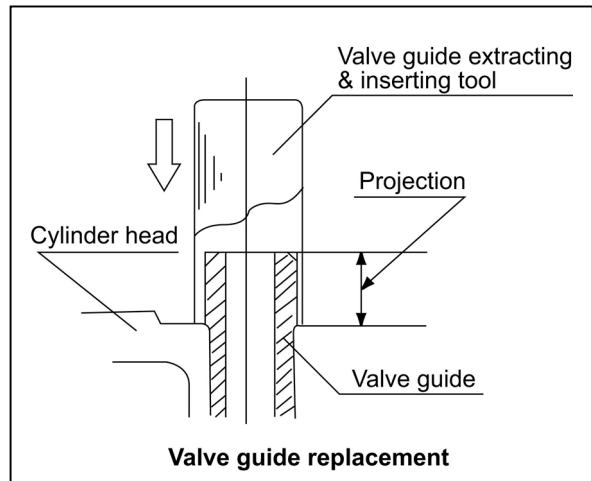
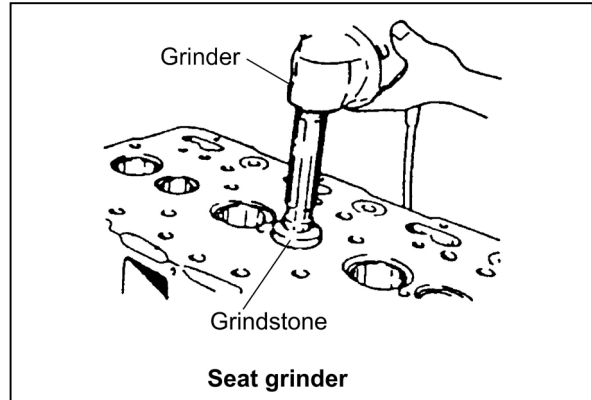

### 4.2.8 Valve stem seal replacement

Always use a new seal after the intake/exhaust valve is disassembled. Since the one for the exhaust valve is marked with yellow paint, do not confuse the intake and exhaust valves.

- 1) Apply engine oil to the lip.
- 2) Push with the inserting tool (Refer to No.5 of 4.1.2 in Chapter 4) for installation.

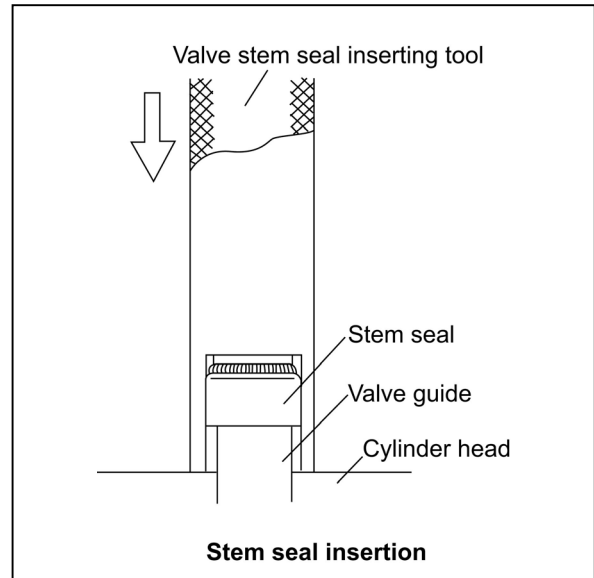

- 3) Measure and check the projection of valve stem seal to keep proper clearance between valve guide and stem seal.

Model	Number of valves	Projection mm
3TNV82A	2 valves	15.7~16.0
4TNV84 3TNV84(T) 4TNV88		18.7~19.0
4TNV84T		9.9~10.2
4TNV94L 4TNV98(T)	4 valves	11.7~12.0
4TNE106(T)		15.4~15.6

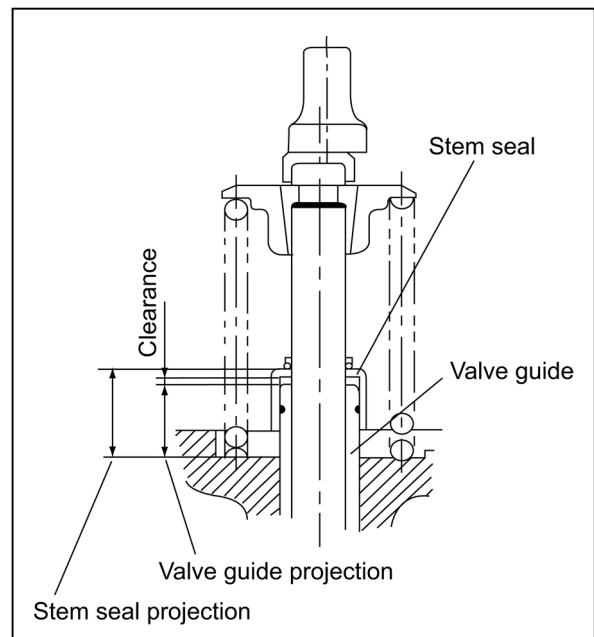

## 4.3 Gear Train and Camshaft

### 4.3.1 Components

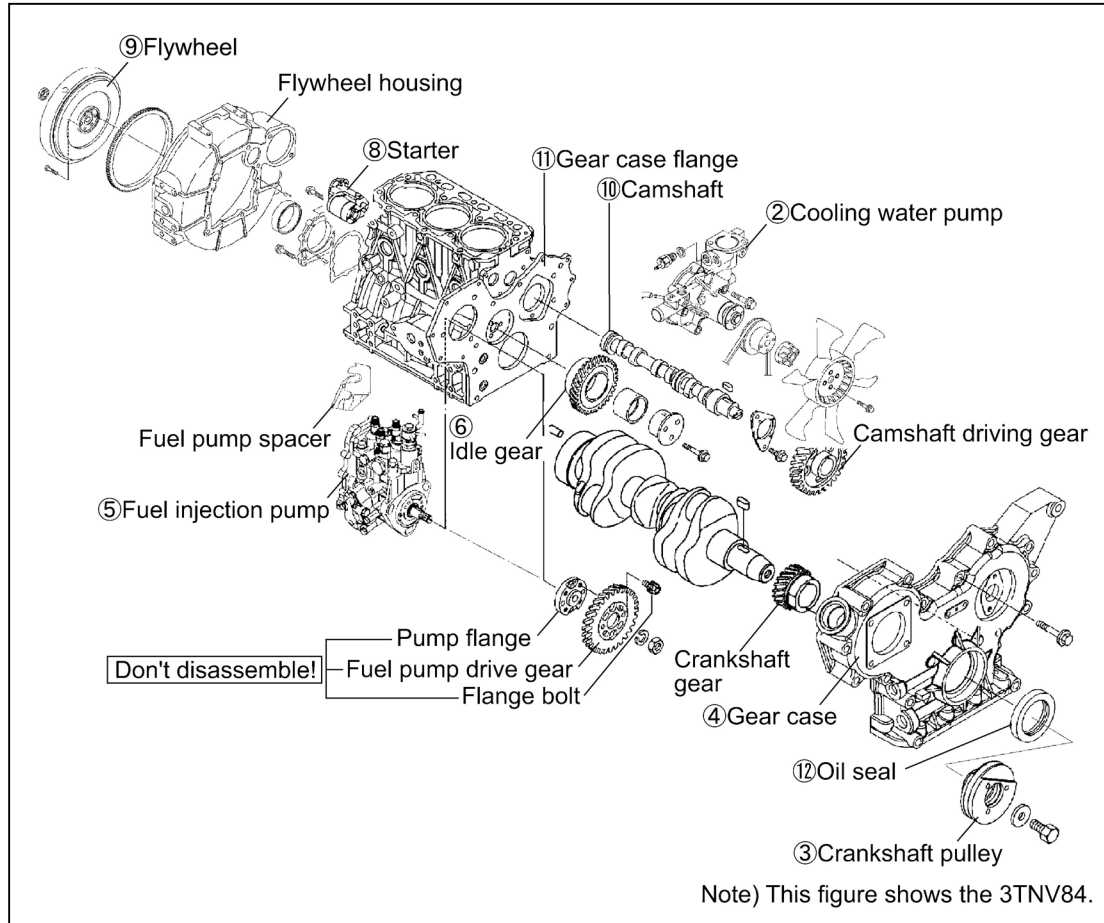

### 4.3.2 Disassembly procedure:

Disassemble in the order of the numbers in the illustration.

- 1) Perform steps 1) to 12) of the cylinder head disassembly procedure.
- 2) Remove the cooling water pump.
- 3) Remove the crankshaft pulley. (See **Point 1** of 4.3.4)
- 4) Remove the gear case cover. (See **Point 2** of 4.3.4)
- 5) Remove the fuel injection pump. (See **Point 3** of 4.3.4)
- 6) Remove the idle gear assy. (See **Point 4** of 4.3.4)
- 7) Remove the PTO drive gear. (See **Point 5** of 4.3.4)
- 8) Remove the starting motor.
- 9) Remove the flywheel. (See **Point 6** of 4.3.4)
- 10) Remove the camshaft assy. (See **Point 7** of 4.3.4)
- 11) Remove the gear case. (See **Point 8** of 4.3.4)
- 12) Remove the oil seal from the gear case cover. (See **4.3.6**)

### 4.3.3 Reassembly procedure:

Reverse of the disassembly procedure.

### 4.3.4 Servicing points

**Point1**

[Disassemble]

- Remove the crankshaft pulley using a gear puller after removing the crankshaft pulley set bolt. When removing the pulley using the gear puller, use a pad and carefully operate so as not to damage the thread. Set the gear puller securely to prevent the pulley from being damaged.

[Reassemble]

- Apply lithium grease to the oil seal lips. For the oil seal with double lips dust seal, further slightly apply engine oil on the lips so as not to damage them.
- Clean by wiping off any oil on both taper surfaces using detergent.
- Be sure to use the crankshaft pulley installing tool so as not to damage the oil seal lips. (See 4.3(6) Oil seal replacement)
- When installing the crankshaft pulley, apply lube oil to the set bolt to tighten and carefully assemble so as not to damage the oil seal.

N·m(kgf-m)

Model	Tightening torque
3TNV82A~TNV88	112.7~122.7 (11.5~12.5)
4TNV94L/98/106(T)	107.9~127.5 (11.0~13.0)

**Point2**

[Reassemble]

- When installing the gear case, do not forget to install the two reinforcing bolts at the center.
- Measure the backlash of each gear.

mm

3TNV82A~88	Standard	Limit
Crankshaft gear, Camshaft gear, Fuel injection pump gear, Idle gear, PTO gear,	0.07~0.15	0.17
Lubricating oil pump gear	0.11~0.19	0.21

4TNV94L-106(T)	Standard	Limit
Crankshaft gear, Camshaft gear, Fuel injection pump gear, Idle gear, PTO gear,	0.08~0.14	0.16
Balancer gear (only 4TNV106(T) )	0.12~0.18	0.20
Lubricating oil pump gear	0.09~0.15	0.17

- Apply sealant and install the gear case by correctly positioning the two dowel pins.

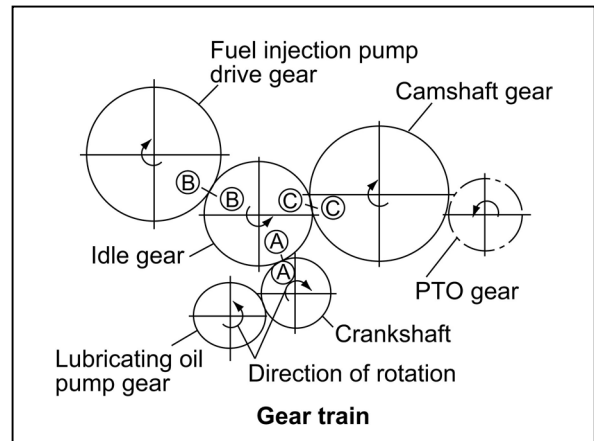

**Point3: (Refer to 7.2.5 in chapter 7)**

[Disassemble]

- Remove the mounting nut of the fuel injection pump drive gear, remove the gear using the gear puller, and remove the fuel injection pump. Do not forget to remove the stay on the rear side. When extracting the gear using the gear puller, use a pad at the shaft and carefully operate so as not to damage the thread.

[Reassemble]

- Tightening torque for fuel pump drive gear nut (without lube. Oil)

N·m(kgf-m)	
Model	Tightening torque
TNV82A~88	78~88 (8.0~9.0)
4TNV94L/98/106(T)	113~123 (11.5~12.5)

**Point4**

[Reassemble]

- Assemble crankshaft gear A, fuel injection pump drive gear B and camshaft gear C at the same time by aligning with idle gear A, B and C marks.
- Install the idle gear shaft with the oil hole facing upward.

**Point5**

[Reassemble]

- Install the PTO drive gear with its inner spline side facing the flywheel.

**Point6**

[Disassemble]

- Install a bolt as a handle in the hole at the end face of the flywheel and remove carefully so as not to damage the ring gear.

[Reassemble]

Flywheel mounting bolt : apply lube oil

N·m(kgf-m)	
Model	Tightening torque
3TNV82A~88	83.3~88.2 (8.5~9.0)
4TNV94L/98/106(T)	186.2~205.8 (19.0~21.0)

**Point7**

[Disassemble]

- Measure the camshaft side gap.

mm		
Item	Standard	Limit
Side gap	0.05~0.20	0.30

- If the measured side gap exceeds the limit, replace the thrust metal.

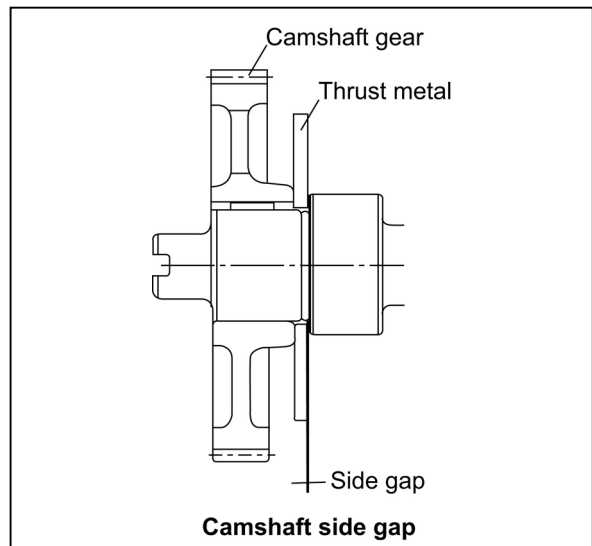



[Disassemble]

- Since the camshaft gear is shrink-fit, heat it to 180°C~200°C for extraction.
- For camshaft removal, raise the engine with its mounting flange at the bottom. After removing the thrust metal mounting bolt from the camshaft gear hole, extract the camshaft carefully so as not to damage the bearing bushing.
- Rotate the camshaft a few turns before extracting it to prevent the tappet from being caught by the cam.
- After removing the camshaft, set the engine horizontal and fix it on the base.

**⚠ CAUTION**

Unforeseen injury may arise due to falling or slipping when raising the engine vertically or returning it to the horizontal position. Proceed carefully so as not to lose balance.

**Point8: Gear case**

[Reassemble]

- Do not forget to install the oil pan mounting bolts on the bottom side when installing the gear case.
- Apply sealant (code No.977770-01212) and install the gear case by matching the two dowel pins.

### 4.3.5 Parts inspection and measurement

(1) Camshaft

Mainly check the contact between the tappet and cam contact surface, bearing seizure and wear, and gear damage.

(a) Shaft bend measurement

Support the camshaft with V blocks. Rotate the camshaft and measure the runout at the center of the camshaft and at each journal with a dial gage. half of the runout is the bend.

Item	Standard	Limit
Bend	0~0.02	0.05

mm

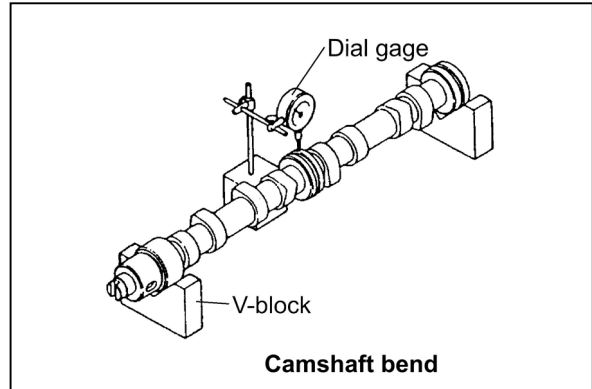

(b) Intake/exhaust cam height measurement

Model	Standard	Limit
3TNV82A~88	38.600~38.800	38.350
4TNV94L·98	43.400~43.600	43.150
4TNV106(T)	50.900~51.100	50.650

mm

(c) Camshaft outside diameter and bearing hole diameter measurement Measure the camshaft outside diameter with a micrometer. The oil clearance shall be calculated by subtracting the measured camshaft outside diameter from the the camshaft bushing inside diameter after insertion to the cylinder measured with a cylinder gage.

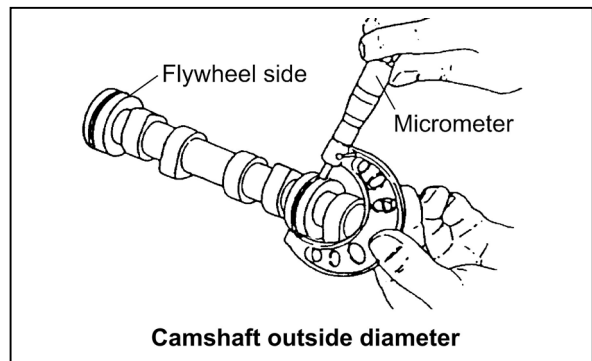

				mm
Model	Place	Item	Standard	Limit
3TNV82A~TNV88	Gear side	Bushing I.D.	44.990~45.055	45.130
		Camshaft O.D.	44.925~44.950	44.890
		Oil clearance	0.040~0.130	0.240
	Intermediate position	Bushing I.D.	45.000~45.025	45.100
		Camshaft O.D.	44.910~44.935	44.875
		Oil clearance	0.065~0.115	0.225
	Wheel side	Bushing I.D.	45.000~45.025	45.100
		Camshaft O.D.	44.925~44.950	44.890
		Oil clearance	0.050~0.100	0.210
TNV94L/98(T)	Gear side	Bushing I.D.	49.990~50.055	50.130
		Camshaft O.D.	49.925~49.950	49.890
		Oil clearance	0.040~0.130	0.240
	Intermediate position	Bushing I.D.	50.000~50.025	50.100
		Camshaft O.D.	49.910~49.935	49.875
		Oil clearance	0.065~0.115	0.225
	Wheel side	Bushing I.D.	50.000~50.025	50.100
		Camshaft O.D.	49.925~49.950	49.890
		Oil clearance	0.05~0.100	0.210
4TNV106(T)	Gear side	Bushing I.D.	57.980~58.050	58.105
		Camshaft O.D.	57.910~57.940	57.875
		Oil clearance	0.040~0.140	0.250
	Intermediate position	Bushing I.D.	58.000~58.030	58.105
		Camshaft O.D.	57.895~57.925	57.860
		Oil clearance	0.075~0.135	0.245
	Wheel side	Bushing I.D.	58.000~58.030	58.105
		Camshaft O.D.	57.910~57.940	57.875
		Oil clearance	0.050~0.120	0.230

(2) Idle gear

Mainly check the bushing seizure and wear, and gear damage.

Shaft outside diameter and bushing inside diameter measurement

			mm
Item	Standard	Limit	
Shaft outside diameter	45.950~49.975	45.900	
Bushing inside diameter	46.000~46.025	46.075	
Clearance	0.025~0.075	0.175	

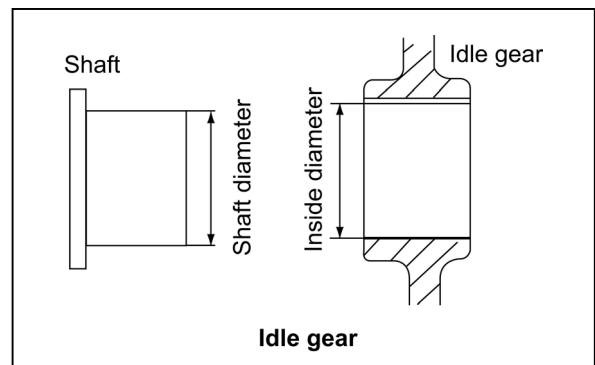

(3) PTO drive gear

Mainly check sticking of bearings on both sides, gear damage and looseness, and gear shaft damage and wear.

### 4.3.6 Oil seal replacement (Gear case side)

- 1) Replace the oil seal with a new one when the gear case is disassembled. Extract the used oil seal.
- 2) Insert a new oil seal. Fit the position of the oil seal insertion to the end face of the gear case. (Refer to the below figure.)
- 3) Apply lithium grease to the oil seal tips. For the oil seal with double lips dust seal, further, slightly apply engine oil on the oil seal lip so as not to damage them, when installing the pulley.

**[NOTICE]**

Pay attention not to drop any oil on the taper surface of the crankshaft. If dropped, clean by wiping off using detergent.

- 4) Carefully install the crankshaft pulley so as not to damage the oil seal lips. Especially for the engine installed the oil seal with double lips dust seal, be sure to use the crankshaft pulley-installing tool.

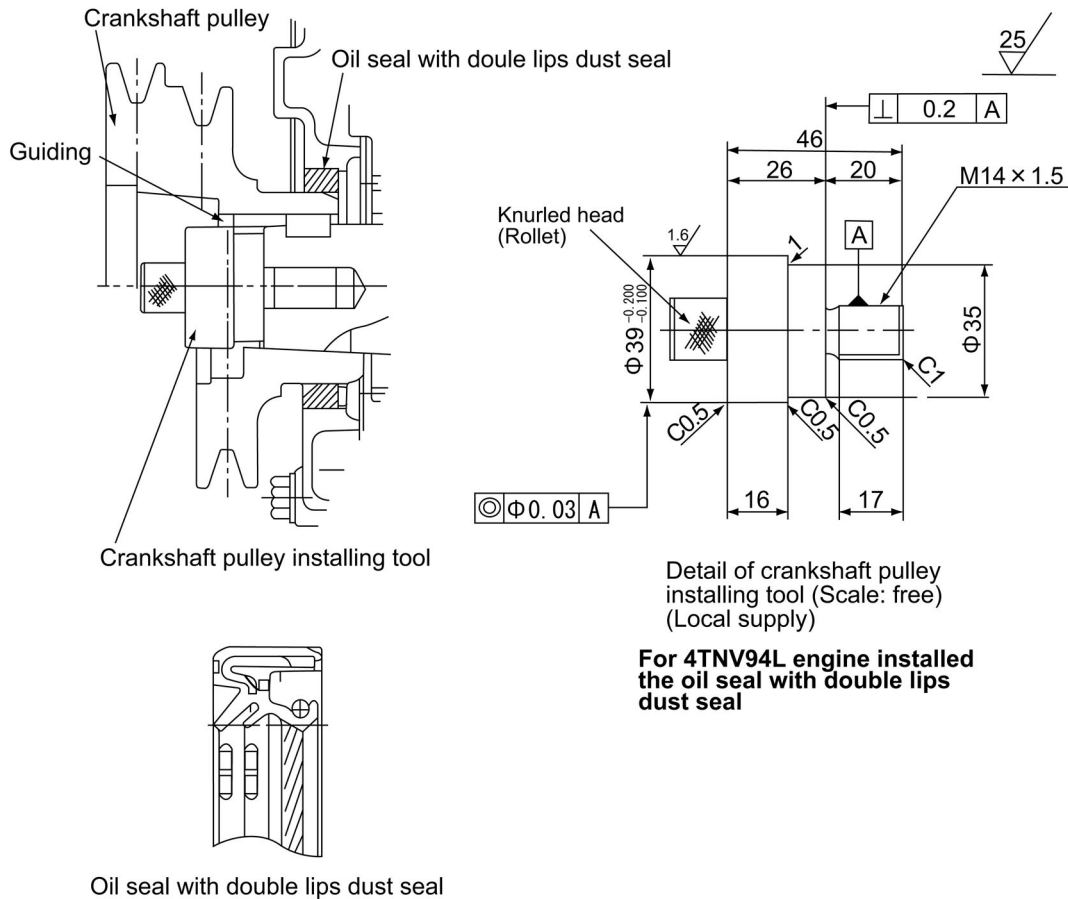

### 4.3.7 Camshaft bushing replacement

Replace the bushing using the special service tool (Refer to No.7 of 4.1.2 in Chapter 4).

## 4.4 Cylinder Block

### 4.4.1 Components

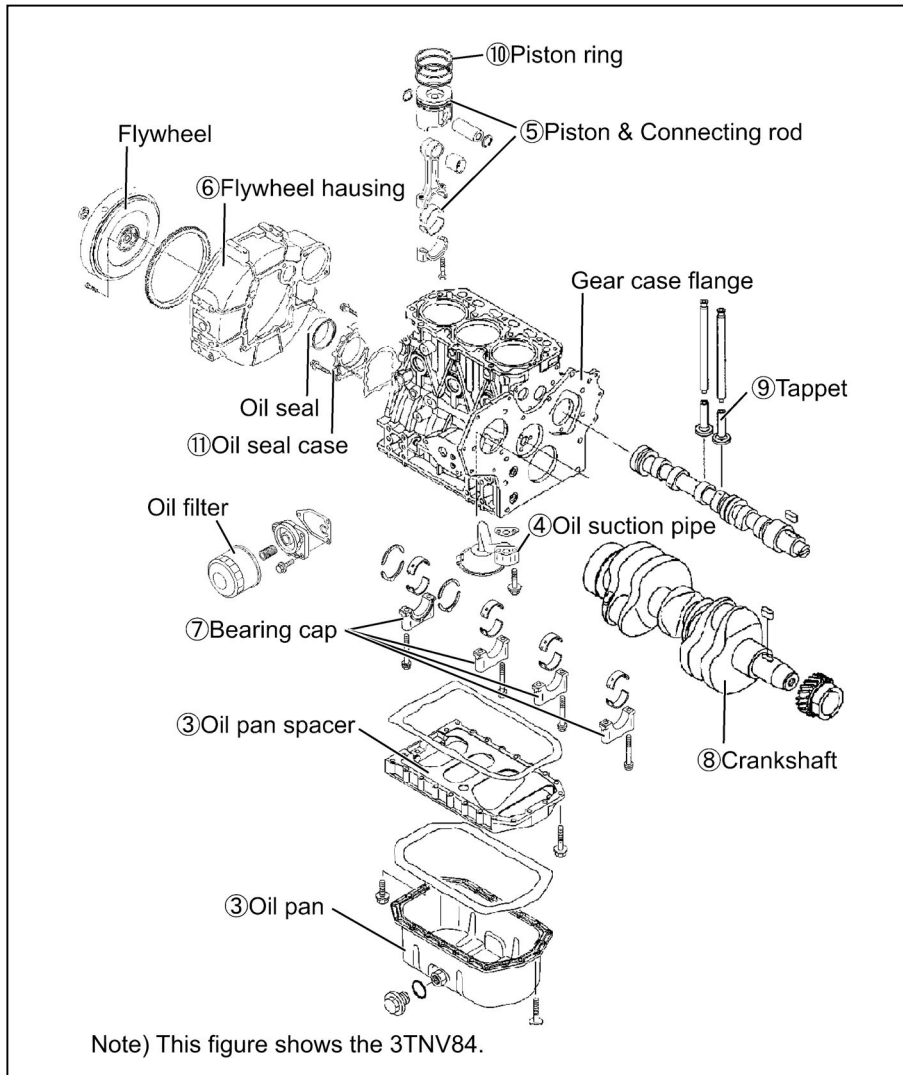

### 4.4.2 Disassembly procedure:

Disassemble in the order of the numbers in the illustration.

- 1) Perform steps 1) to 12) in the cylinder head disassembly procedure.
- 2) Perform steps 1) to 12) in the gear train disassembly procedure.
- 3) Remove the oil pan. (See **Point 1** of 4.4.4)
- 4) Remove the lubricating oil suction pipe.
- 5) Remove the piston w/rod. (See **Point 2** of 4.4.4)
- 6) Remove the mounting flange. (See **Point 3** of 4.4.4)
- 7) Remove the bearing metal caps. (See **Point 4** of 4.4.4)
- 8) Remove the crankshaft. (See **Point 5** of 4.4.4)
- 9) Remove the tappets.
- 10) Remove the pistons and rings. (See **Point 6** of 4.4.4)
- 11) Remove the oil seal from the mounting flange. (See **4.4.8** of 4.4.4)

### 4.4.3 Reassembly procedure:

Reverse of the disassembly procedure.

### 4.4.4 Servicing points

**Point1: Oil pan**

[Disassemble]

- Sealant is applied to the oil pan mounting surface on the block. Carefully operate so as not to damage or distort the bonding surface.

[Reassemble]

- Apply sealant (code No.977770-01212) before reassembly.

**Point2: Piston w/rod**

[Disassemble]

- Measure the connecting rod side gap.

	mm
Standard	0.20~0.40

- Carefully remove the carbon deposit on top of the cylinder so as not to damage the inner side of the cylinder.
- Set the piston at the BDC position and remove the connecting rod cap. Then set the piston at the TDC position, and push the connecting rod big end with the wooden shaft of a hammer. Proceed carefully so as not to cause the cylinder block catch the rod big end. Set the rod caps and crankpin metals in their correct combinations.

[Reassemble]

- Apply oil especially carefully to the sliding contact surfaces of the pistons, rods and rings.
- Use the piston insertion tool (see 12.1-9 in Chapter 12) to insert each piston w/rod in the cylinder block and install the bearing metal cap.

Rod bolt tightening torque N·m(kgf·m)

Model	Standard (apply lube oil)
3TNV82A	37.2~41.2 (3.8~4.2)
TNV84~88	44.1~49.0 (4.5~5.0)
4TNV94L·98	53.9~58.8 (5.5~6.0)
4TNV106(T)	78.5~83.4 (8.0~8.5)

**Point3: mounting flange**

[Disassemble]

Place the engine on a stable base with the cylinder block upper surface facing down, and remove the mounting flange carefully so as not to damage the combustion surface.

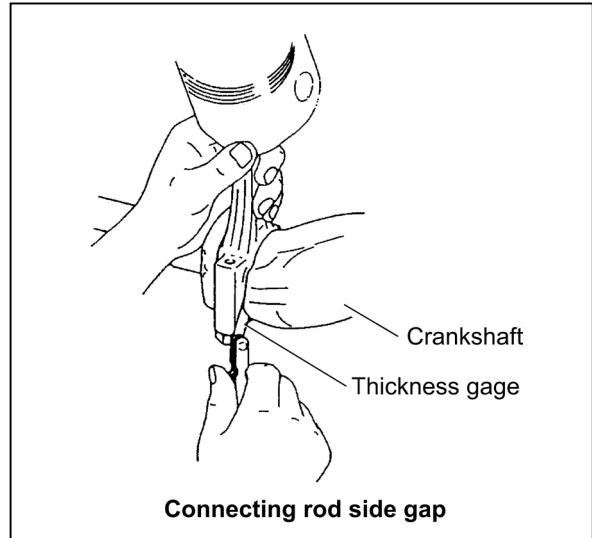

[Reassemble]

Apply sealant (code No.977770-01212) and install the mounting flange by matching the two dowel pins. After assembly, raise the engine with its mounting flange on the bottom side.

**CAUTION**

Unforeseen injury may arise due to falling or slipping when raising or reversing the engine. Carefully operate so as not to lose balance.

**Point4: Journal bearing cap**

[Disassemble]

- Before removing the journal bearing, measure the crankshaft side gap. Measure it in either method because there are the next two methods.

1) Install a dial gage on the cylinder block, and move a crankshaft in front and back, and measure the side gap as shown in the right figure.

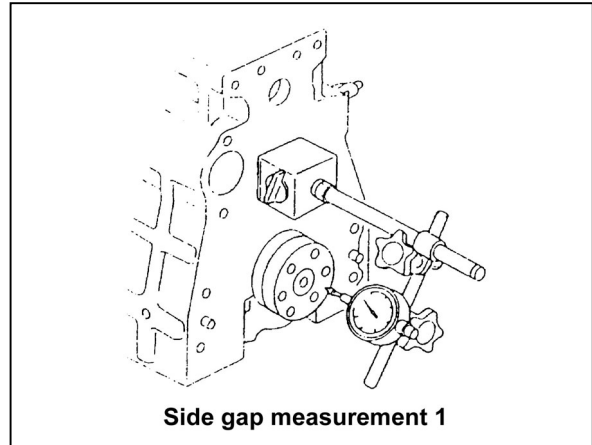

2) Put a thickness gauge in the clearance between thrust metal and crankshaft directly, and measure it.

Side gap standard mm

Model	Standard	Limit
All models	0.13~0.23	0.28

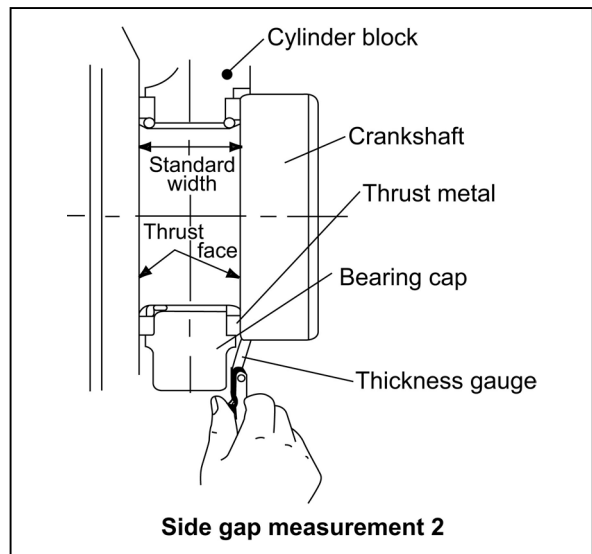

[Reassemble]

- If the side gap exceeds the standard, replace the thrust metal with an oversized one. Machine the standard width of the crankshaft thrust part into the dimension of the below table at the same time.

Refer to a parts catalog when ordering the part.

The surface finishing precision (refer to 4.4.5(2) in Chapter4):



0.25mm Oversized thrust metal (0.25DS) mm

0.25DS	Thrust metal assy code	Standard thickness
3TNV82A	119810-02940	2.055~2.105
TNV84~88	129150-02940	2.055~2.105
4TNV94L·98	129900-02940	2.055~2.105
4TNV106(T)	123900-02940	2.555~2.605

The standard width of the crankshaft thrust part

mm

Model	Standard thickness
3TNV82A	25.250~25.271
TNV84~88	28.250~28.271
4TNV94L·98	32.250~32.275
4TNV106(T)	36.250~36.275

[Disassemble]

- Remove the bearing caps, cap side bearings, and thrust metals. Place each thrust metal with identification of the position and direction.

The position number of reassembling is punched on a metal cap (except for both ends) and a cylinder block.

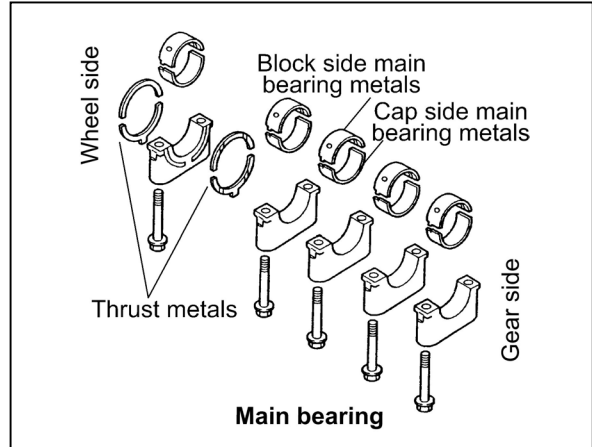

[Reassemble]

- Carefully install each thrust metal so that the grooved one is positioned away from the cap.
- Do not confuse the upper and lower main bearing metals. The upper main bearing metal (block side) has an oil hole, and the lower one does not. The "arrow" marks on the cap shall face the flywheel. Tighten main bearing cap bolts.

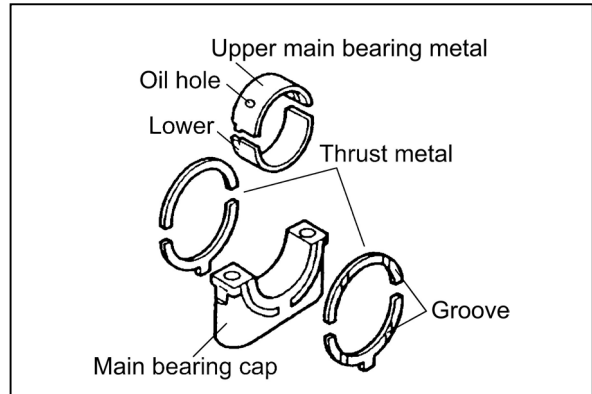

Main bearing cap bolt tightening torque  
(apply lube oil)

Model	Nm(kgf·m)	
	Standard	
3TNV82A	76.4~80.4 (7.8~8.2)	
TNV84~88	93.2~98.1(9.5~10.5)	
4TNV94L·98	108.1~117.9 (11.0~12.0)	
4TNV106(T)	186.2~205.8 (19.0~21.0)	

**Point5: Crankshaft**

[Disassemble]

- Remove the crankshaft. Remove each main bearing metal upper (block side) and pair it with the metal cap side lower metal.

**CAUTION**

Carefully prevent damage to the bearing or finger injury when removing the crankshaft because it is heavy.

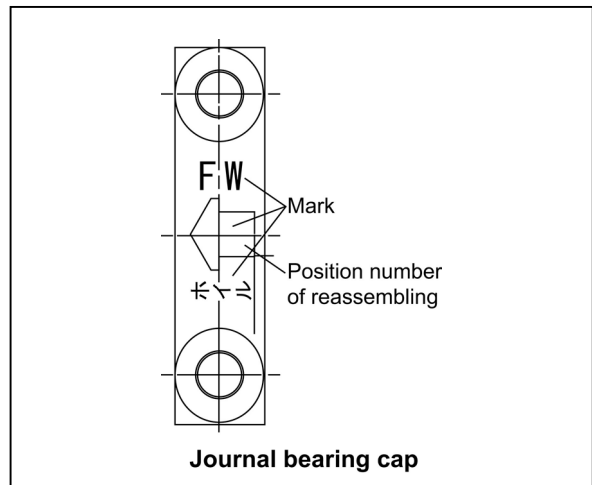



**Point6: Piston pin and rings**

[Disassemble]

- Using the piston ring replacer (see 4.1.2 in Chapter 4), remove the piston rings.
- Remove the circlip and remove the piston pin by pushing it out.

[Reassemble]

- Install each piston ring on the piston, with the punched manufacturer's mark facing upward.

[Reassemble]

- The piston ring joints shall be staggered at by 120° intervals. Do not position the top ring joint vertical to the piston pin. The coil expander joint shall be opposite to the oil ring joint.

[Reassemble]

- When installing the piston pin to the rod and piston, the punched match mark on the big end of the connecting rod shall be opposite to the size mark on the piston top.

[Reassemble]

- Install the piston in the cylinder clock with the punched mark on the big end of the rod on the nozzle side. (The embossed mark at the connecting rod I-beam section shall be on the flywheel side.)

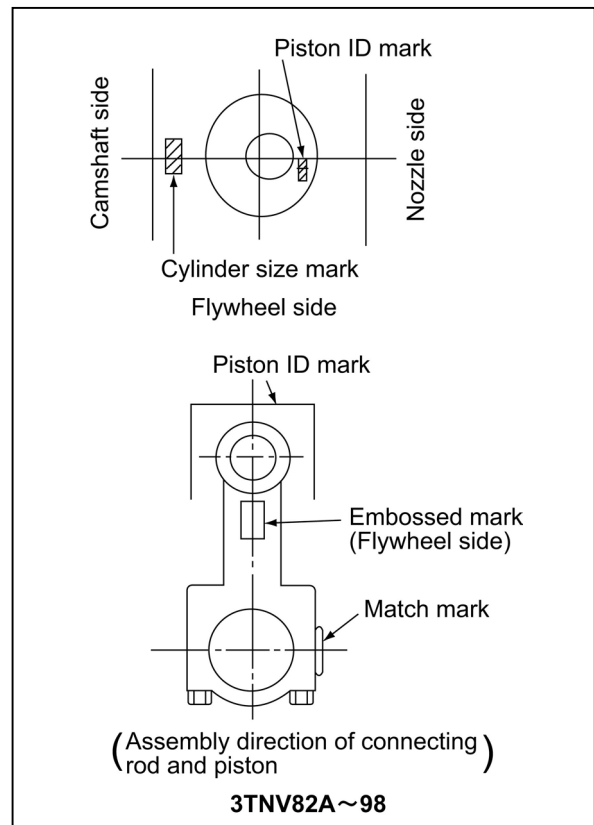
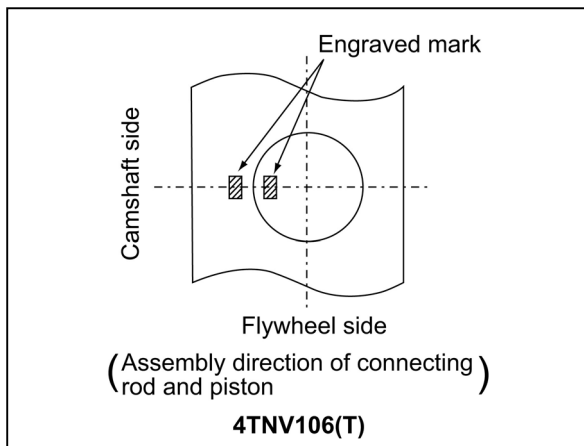
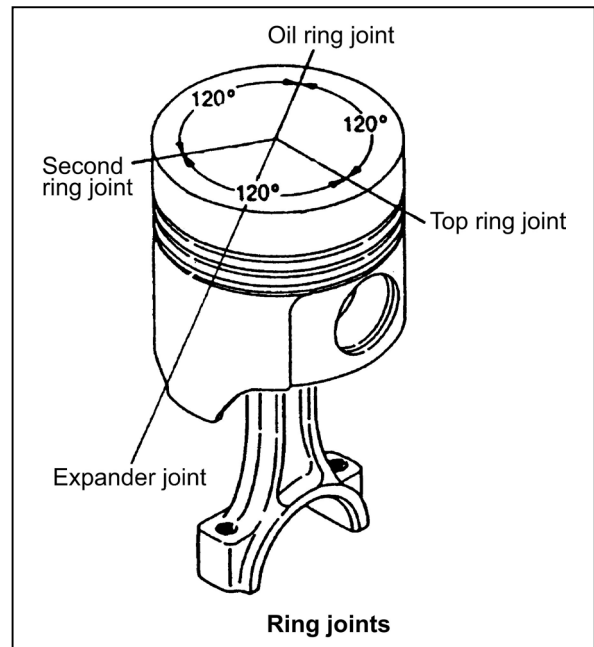
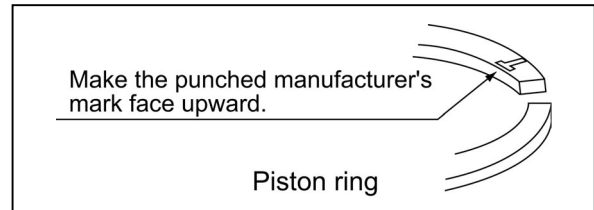

### 4.4.5 Parts inspection and measurement

(1) Cylinder block

Especially clean head surface, cylinder bores and oil holes, and check after removing any carbon deposit and bonding agent.

(a) Appearance inspection

Check if there is any discoloration or crack. If crack is suspected, perform color check. Sufficiently clean the oil holes and check they are not clogged.

(b) Cylinder bore and distortion

Measure at 20 mm below the crest of the liner, at 20 mm from the bottom end and at the center.

**Roundness:**

Roundness is found as follows though it is the simple method. Measure cylinder diameters of the A direction and the B direction on each section of a, b and c.

Roundness is the maximum value among those difference values.

**Cylindricity:**

Cylindricity is found as follows though it is the simple method.

Measure cylinder diameters of a, b and c sections in the A direction, and calculate the difference in maximum value and minimum value of the measured diameters.

In the same way measure and calculate the difference in the B direction.

Cylindricity is the maximum value between those difference values.

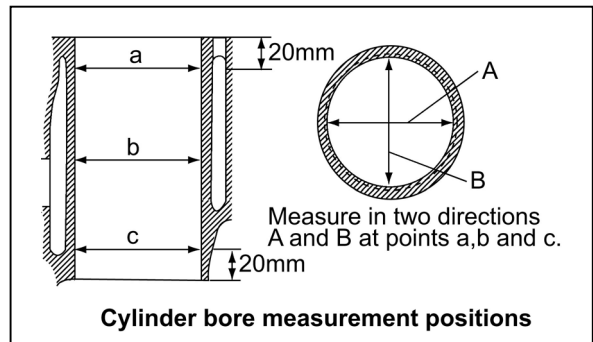
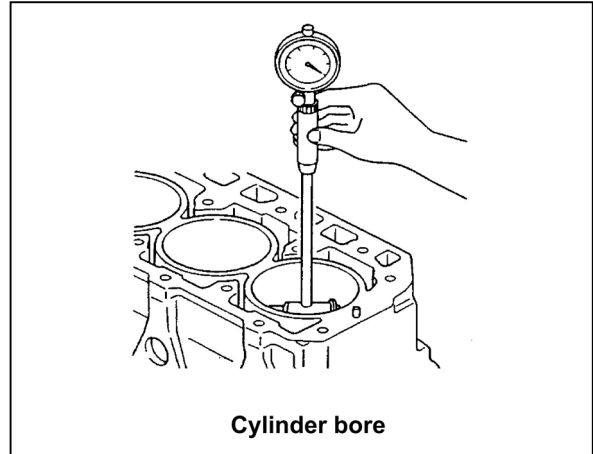

Item		Model	Standard	Limit
Cylinder inside diameter		3TNV82A	82.000~82.030	82.200
		TNV84	84.000~84.030	84.200
		TNV88	88.000~88.030	88.200
		4TNV94L	94.000~94.030	94.130
		4TNV98	98.000~98.030	98.130
		4TNV106(T)	106.000~106.030	106.130
Cylinder bore	Roundness	all TNV	0.01 or less	0.03
	Cylindricity			

mm

(c) If the limit is exceeded or any surface defect is found, repair by boring and honing. Use an oversized piston (and new piston rings) as required.

Oversized piston (0.25 mm, with piston rings)

Model	Code No.	Standard (mm)
3TNV82A	719802-22900	82.250
3TNV84(T) 4TNV84	129004-22900	84.250
4TNV84T	129508-22900	84.250
3/4TNV88	129005-22900	88.250
4TNV94L	729906-22900	94.250
4TNV98	129902-22700	98.250
4TNV106	729907-22900	106.250
4TNV106T	723907-22910	106.250

Piston ring assy for oversized (0.25mm)

Model	Piston ring code No.
3TNV82A	719802-22950
3TNV84(T) 4TNV84	129004-22950
4TNV84T	129004-22950
3/4TNV88	129005-22950
4TNV94L	729906-22950
4TNV98	729907-22950
4TNV106(T)	723907-22950

Cylinder dimension after boring and honing

Model	Cylinder dimension (mm)	Honing angle (deg.)	Surface roughness	Roundness/Cylindricity (mm)
3TNV82A	82.250~82.280	30~40 deg.	$R_{max}$ 1.0~3.5S	0.01 or less
3TNV84(T) 4TNV84	84.250~84.280			
3/4TNV88	88.250~88.280			
4TNV94L	94.250~94.280			
4TNV98	98.250~98.280			
4TNV106(T)	106.250~106.280			

**(2) Crankshaft**

Mainly check seizure and wear of the crankpins and journals. Since the crankshaft gear is shrink-fitted, heat to 180 to 200°C when extraction is necessary.

**(a) Shaft portion color check**

After washing the crankshaft, inspect it by means of color check or a magnaflux inspector. Replace it if cracked or heavily damaged. Slight defects shall be corrected by grinding.

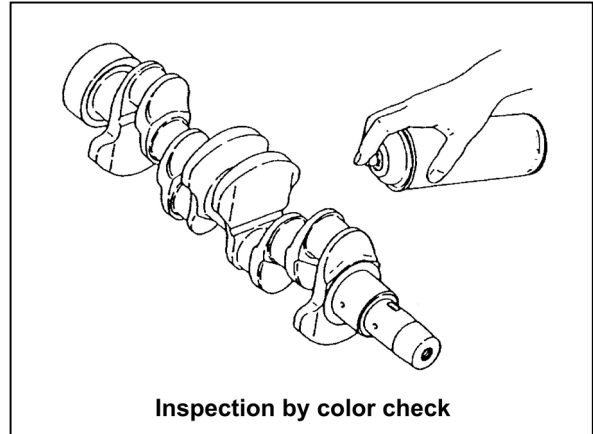

**(b) Crankshaft bend**

Support the crankshaft journals at both ends with V-blocks. Use a dial gage and measure the runout at the center journal while rotating the shaft to inspect the bend.

Limit	0.02mm or less
-------	----------------

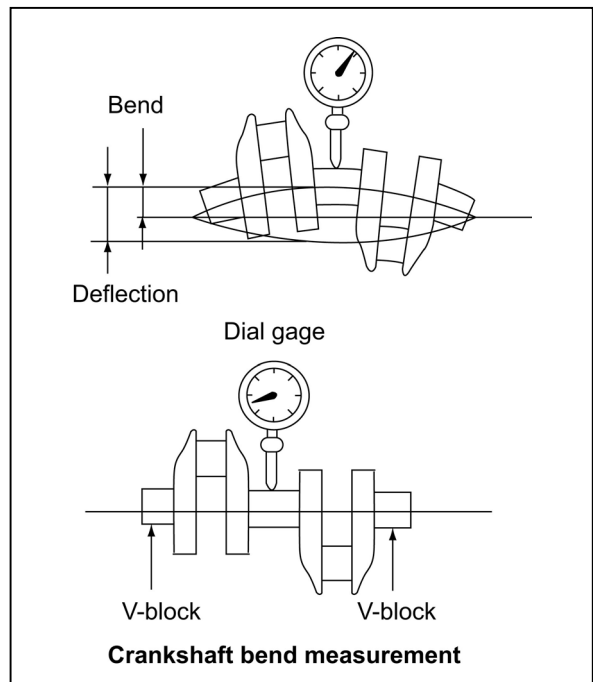

**(c) Crankpin and journal measurement**

Measure the outside diameter, roundness and taper at each crankpin and journal.

Correct by grinding if unevenly wear, roundness exceeding the limit or insufficient outside diameter is found. Replace if the defect is excessive.

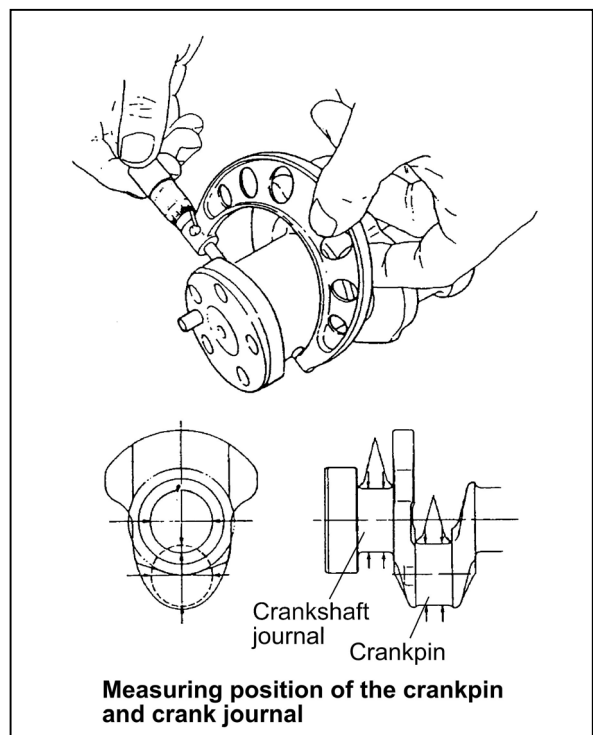

Crankpin		mm	
Model & Item	Standard	Limit	
3TNV82A	Pin outside diameter	42.952~42.962	42.902
	Metal thickness	1.487~1.500	-
	Oil clearance	0.038~0.090	0.150
TNV84~88	Pin outside diameter	47.952~47.962	47.902
	Metal thickness	1.492~1.500	-
	Oil clearance	0.038~0.074	0.150
4TNV94L·98	Pin outside diameter	57.952~57.962	57.902
	Metal thickness	1.492~1.500	-
	Oil clearance	0.038~0.074	0.150
4TNV106(T)	Pin outside diameter	63.952~63.962	63.902
	Metal thickness	1.984~1.992	-
	Oil clearance	0.054~0.090	0.150

If the oil clearance exceeds the limit, use an undersized bearing.

#### Undersized crankpin bearing (0.25 mm)

Model	Code No.	Standard thickness (mm)
3TNV82A	119810-23610	1.612~1.625
TNV84~88	129150-23610	1.617~1.625
4TNV94L·98	129900-23610	1.617~1.625
4TNV106(T)	123900-23610	2.109~2.117

#### Pin machining dimension

Model	Pin machining dimension (mm)
3TNV82A	$\phi 42.702 \sim 42.712$
TNV84~88	$\phi 47.702 \sim 47.712$
4TNV94L·98	$\phi 57.702 \sim 57.712$
4TNV106(T)	$\phi 63.702 \sim 63.712$

Crank journal			mm
Model	Item	Standard	Limit
3TNV82A	Journal O.D.	46.952~46.962	46.902
	Metal thickness	1.987~2.000	-
	Oil clearance	0.038~0.080	0.150
TNV84~88 (Selective assembly)	Journal O.D.	53.952~53.962	53.902
	Metal thickness	1.995~1.990	-
	Oil clearance	0.038~0.068	0.150
4TNV94·98 (Selective assembly)	Journal O.D.	64.952~64.962	64.902
	Metal thickness	1.995~2.010	-
	Oil clearance	0.038~0.068	0.150
4TNV106(T) (Selective assembly)	Journal O.D.	75.952~75.962	75.902
	Metal thickness	2.488~2.503	-
	Oil clearance	0.052~0.082	0.150

If the clearance limit is exceeded, use an undersized bearing.

Undersized bearing (0.25mm)

Model	Code No.	Standard thickness (mm)
3TNV82A	119810-02870	2.112~2.125
TNV84~88	129150-02870	2.112~2.125
4TNV94L·98	129900-02340	2.112~2.125
4TNV106(T)	12900-02340	2.605~2.618

Crankshaft Journal machining dimension

Model	Journal machining dimension (mm)
3TNV82A	$\phi 46.702 \sim 46.712$
TNV84~88	$\phi 53.702 \sim 53.712$
4TNV94/98	$\phi 64.702 \sim 64.712$
4TNV106(T)	$\phi 75.702 \sim 75.712$

- Dimension R and finishing precision of crankshaft journal and pin

As for grinding processing of journal and pin, machine it by using the grinding wheel of the dimension R of below table.

Surface finishing precision standard on journal and pin:

Ry=0.8S super polishing

Surface finishing precision standard on the thrust side of crankshaft arm:

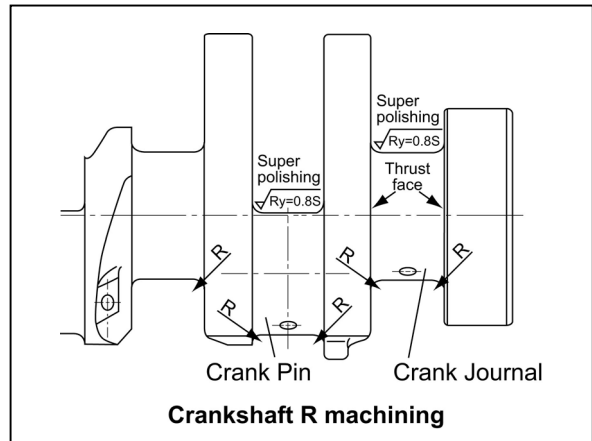

Model	Finishing precision standard of dimension R
3TNV82A TNV84~88	3.5 +0.3/ 0
4TNV94L/98(T) 4TNV106(T)	4.0 +0.3/ 0

[NOTICE]

- 1) If the oil clearance is excessive though the thicknesses of the journal and crankpin metals are normal or if partial uneven wear is observed, re-grind the crankshaft and use an oversized metals.
- 2) If rust or surface roughening exists on the rear side of the metals, coat it with blue or minimum. Then assemble the crankpin metal to the connecting rod, and tighten the rod bolt to the specified torque to check the metal for contact. If the contact surface occupies 75% or more, the metal is normal. If the contact surface is insufficient, the metal interference is insufficient. Replace the metal with a new one.

(1) Thrust metal inspection

- (a) Inspect any damage or wear.
- (b) Measure side gap and thrust metal thickness

Side gap and thrust metal thickness mm

Model	Side gap		Thrust metal thickness	
	Standard	Limit	Standard	Limit
TNV82A~88	0.14~0.22	-	1.930~1.980	1.850
4TNV94L·98	0.13~0.23	-	1.930~1.980	1.850
4TNV106(T)	0.13~0.23	-	2.430~2.480	2.35

If the side gap is exceeded, use an oversized thrust metal.

Oversized metal (0.25mm)

-	Code No.		Standard thickness (mm)
	Upper	Lower	
3TNV82A	???119810-02940 (Up-down combination)		2.15
TNV84~88	129150-02940 (Up-down combination)		2.15
4TNV94L·98	129900-02370	129900-02360	2.055~2.105
4TNV106(T)	123900-02370	123900-02360	2.555~2.605

**(4) Piston**

Especially clean the combustion surface, circumference, ring grooves and piston pin bosses, and check after removing any carbon deposit. Any burr at a ring groove or snap ring groove shall be removed. If crack is suspected, inspect by color check.

**(a) Piston outside diameter measurement**

Measure the long diameter at H mm from the bottom end of the piston of the oval hole in the vertical direction to the piston pin hole.

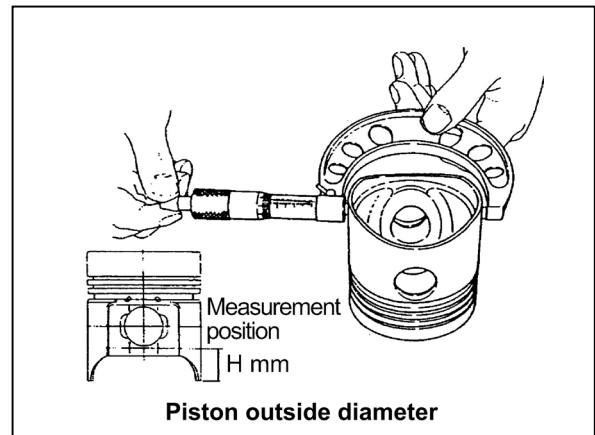

Piston outside diameter

Model	Outside diameter Standard	Limit	Clearance between piston and cylinder	Measurement position (H)
3TNV82A	81.950~81.980	81.905	0.035~0.065	22~25
3,4TNV84(T)	83.945~83.975	83.900	0.040~0.070	
3,4TNV88	87.945~87.975	87.900	0.050~0.080	22
4TNV94L	93.945~93.955	93.900		22
4TNV98(T)	97.940~97.950	97.895		30
4TNV106(T)	105.930~105.960	105.880		

If the clearance between piston and cylinder exceeds the limit, use an oversized piston. (Refer to the tables of oversized pistons, oversized piston rings and cylinder boring dimension on 4.4.5(1)(c) in chapter 4.)

**(b) Piston pin hole measurement**

Measure the outside diameter of piston pin and the inside diameter of piston pin hole. Calculate the clearance between piston pin and piston pin hole. If any data exceeds the limit, replace the part with a new one.

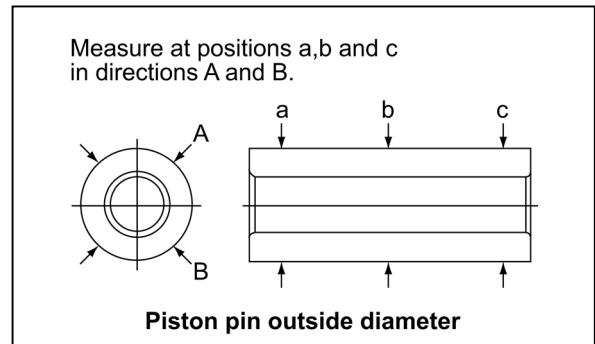

Model	Item	Standard	Limit
3TNV82A	Pin I.D.	23.000~23.009	23.039
	Pin O.D.	22.995~23.000	22.965
	Clearance	0.000~0.014	0.074
TNV84~88	Pin I.D.	26.000~26.009	26.039
	Pin O.D.	25.995~26.000	25.965
	Clearance	0.000~0.014	0.074
4TNV94L · 4TNV98(T)	Pin I.D.	30.000~30.009	30.039
	Pin O.D.	29.989~30.000	29.959
	Clearance	0.000~0.020	0.080
4TNV106(T)	Pin I.D.	37.000~37.011	37.039
	Pin O.D.	36.989~37.000	36.959
	Clearance	0.000~0.022	0.080

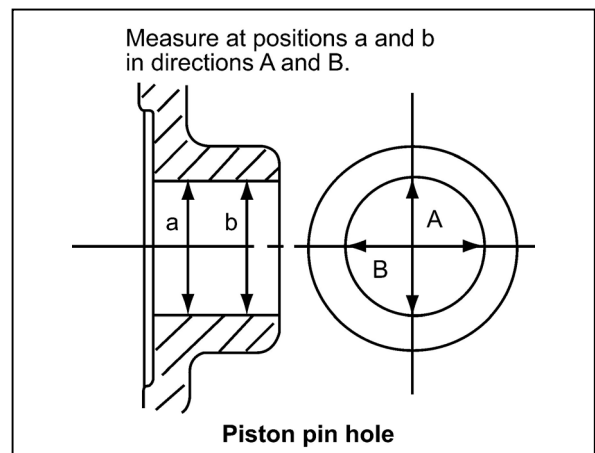



(c) Piston ring, ring groove and end clearance measurement

- Except for the top ring, to measure the piston ring groove width, first measure the width of the piston ring. Then insert the piston ring into the ring. Then insert the piston ring into the ring groove. Insert a thickness gage in between the piston ring and groove to measure the gap between them. Obtain the ring groove width by adding ring width to the measured side clearance.
- To measure the end clearance, push the piston ring into the sleeve using the piston head, insert a thickness gage in end clearance to measure. The ring shall be pushed in to approx. 30 mm above the bottom end of the cylinder. For the top ring, measure only the piston ring joint end clearance in normal state.

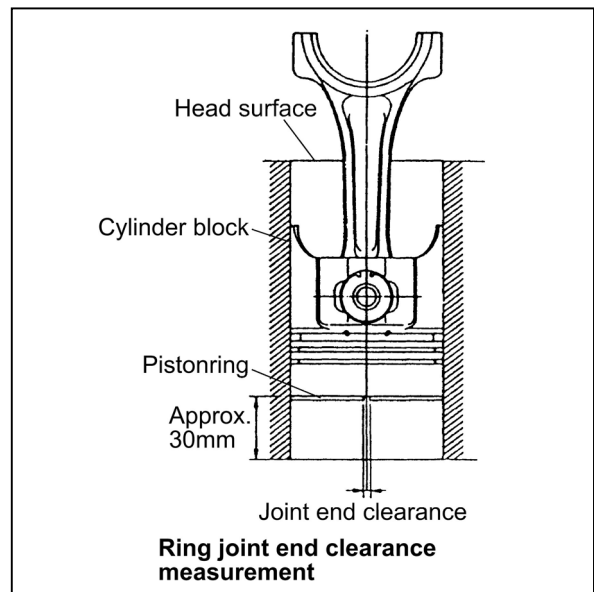
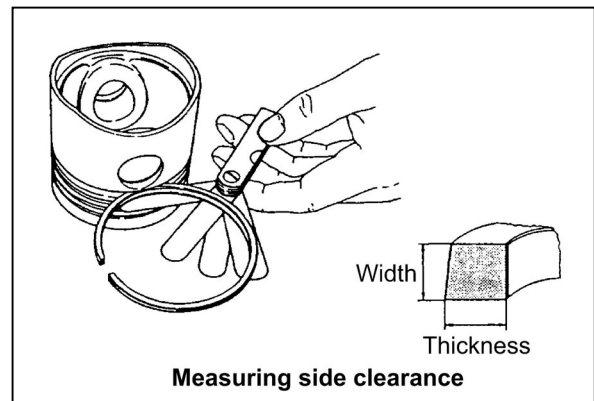
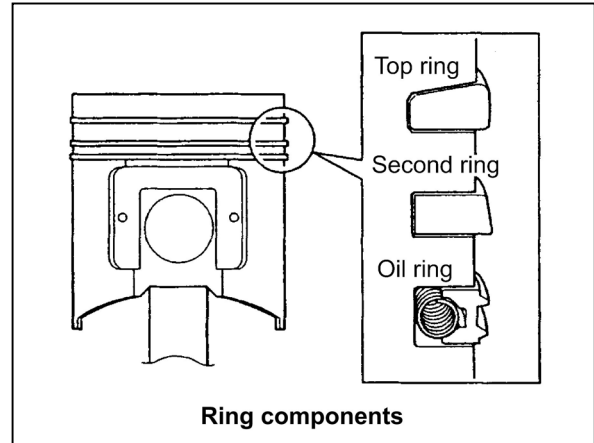

Piston ring dimension

mm

Model	Part	Item	Standard	Limit
TNV82A/84	Top ring	Ring groove width	2.065~2.080	-
		Ring width	1.970~1.990	1.950
		Side clearance	0.075~0.110	-
		End clearance	0.200~0.400	0.490
	Second ring	Ring groove width	2.035~2.050	2.150
		Ring width	1.970~1.990	1.950
		Side clearance	0.045~0.080	0.200
		End clearance	0.200~0.400	0.490
	Oil ring	Ring groove width	4.015~4.030	4.130
		Ring width	3.970~3.990	3.950
		Side clearance	0.025~0.060	0.180
		End clearance	0.200~0.400	0.490
TNV88	Top ring	Ring groove width	2.060~2.075	-
		Ring width	1.970~1.990	1.950
		Side clearance	0.070~0.105	-
		End clearance	0.200~0.400	0.490
	Second ring	Ring groove width	2.025~2.040	2.140
		Ring width	1.970~1.990	1.950
		Side clearance	0.035~0.070	0.190
		End clearance	0.200~0.400	0.490
	Oil ring	Ring groove width	4.015~4.030	4.130
		Ring width	3.970~3.990	3.950
		Side clearance	0.025~0.060	0.180
		End clearance	0.200~0.400	0.490
4TNV94L·98	Top ring	Ring groove width	2.040~2.060	-
		Ring width	1.940~1.960	1.920
		Side clearance	0.080~0.120	-
		End clearance	0.250~0.450	0.540
	Second ring	Ring groove width	2.080~2.095	2.195
		Ring width	1.970~1.990	1.950
		Side clearance	0.090~0.125	0.245
		End clearance	0.450~0.650	0.730
	Oil ring	Ring groove width	3.015~3.030	3.130
		Ring width	2.970~2.990	2.950
		Side clearance	0.025~0.060	0.180
		End clearance	0.250~0.450	0.550
4TNV106(T)	Top ring	Ring groove width	2.520~2.540	-
		Ring width	2.440~2.460	2.420
		Side clearance	0.060~0.100	-
		End clearance	0.300~0.450	0.540
	Second ring	Ring groove width	2.070~2.085	2.185
		Ring width	1.970~1.990	1.950
		Side clearance	0.080~0.115	0.235
		End clearance	0.450~0.600	0.680
	Oil ring	Ring groove width	3.015~3.030	3.130
		Ring width	2.970~2.990	2.950
		Side clearance	0.025~0.060	0.180
		End clearance	0.300~0.500	0.600

(5) Connecting rod

(a) Appearance inspection

Inspect the portion near the boundary of the chamfered portion and I-beam section of the big and small ends of the connecting rod as well as the portion near the oil hole of the bushing at the small end for cracks, deformation, and discoloration.

(b) Twist and parallelism measurement Use a connecting rod aligner and measure the twist and bend.

Item	Standard dimension	Limit dimension
Twist and parallelism	0.03 or less per 100mm	0.08

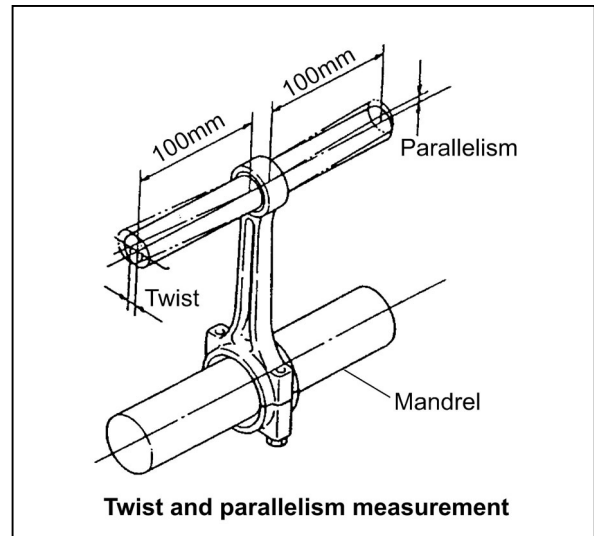

Twist and parallelism measurement

(c) Rod small end measurement

Measure the pin outside diameter according to 4.4.5.(4)(a) described above.

Model	Item	Standard	Limit
3TNV82A	Piston pin I.D. bushing	23.025~23.038	23.068
	Pin O.D.	22.995~23.000	22.967
	Clearance	0.025~0.043	0.101
TNV84~88	Piston pin I.D. bushing	26.025~26.038	26.068
	Pin O.D.	25.995~26.000	25.967
	Clearance	0.025~0.043	0.101
4TNV94L·98	Piston pin I.D. bushing	30.025~30.038	30.068
	Pin O.D.	29.987~30.000	29.959
	Clearance	0.025~0.051	0.109
4TNV106(T)	Piston pin I.D. bushing	37.025~37.038	37.068
	Pin O.D.	36.989~37.000	36.961
	Clearance	0.025~0.049	0.107

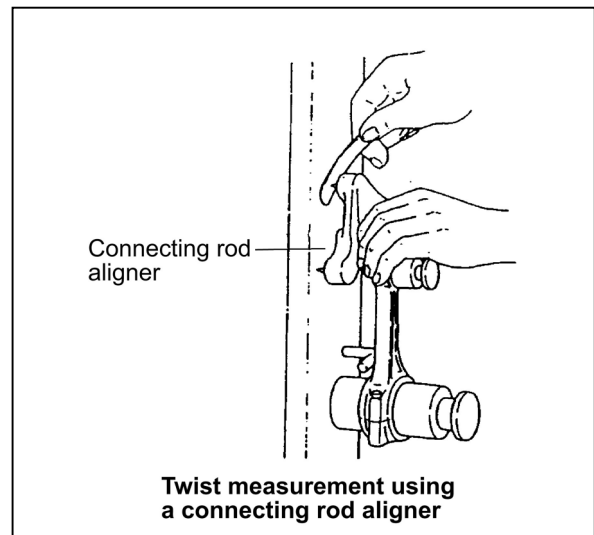

Twist measurement using a connecting rod aligner

If the bushing is to be replaced because the oil clearance exceeds the limit, use spare part.

Model	Service part code
3TNV82A	119810-23910
TNV84~88	129100-23910
4TNV94L·98(T)	129900-23910
4TNV106(T)	123900-23910

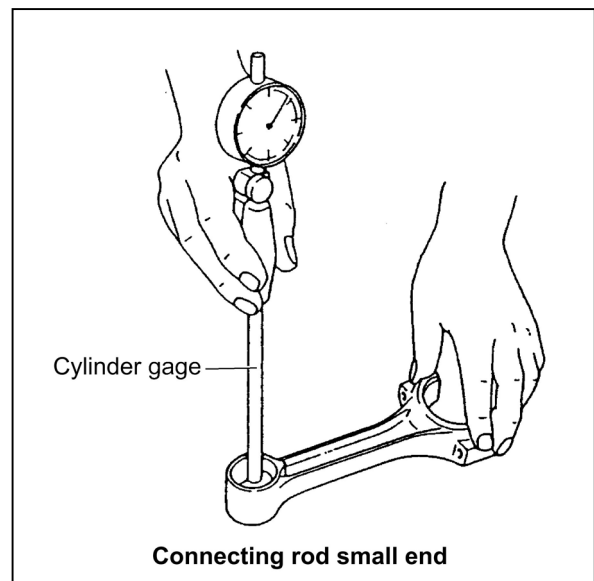

Connecting rod small end

(d) Rod big end measurement

Measure the crankpin and bushing according to 4.4.5.(2)(c) described above.

Calculate the oil clearance of a crank pin metal and a crank pin from the measured values of the crank pin metal inner diameter and the crank pin outside diameter.

Replace a crank pin metal if the oil clearance becomes about the limit dimension of the below table.

Correct by grinding if unevenly wear, roundness exceeding the limit or insufficient outside diameter is found. Also use an undersized metal. (Refer to the above (2) c.)

[NOTICE]

When measuring the inside diameter of the rod big end, install the crankpin metals in the rod big end not to mistake the top and bottom of the metals and tighten the rod bolts by the standard torque.

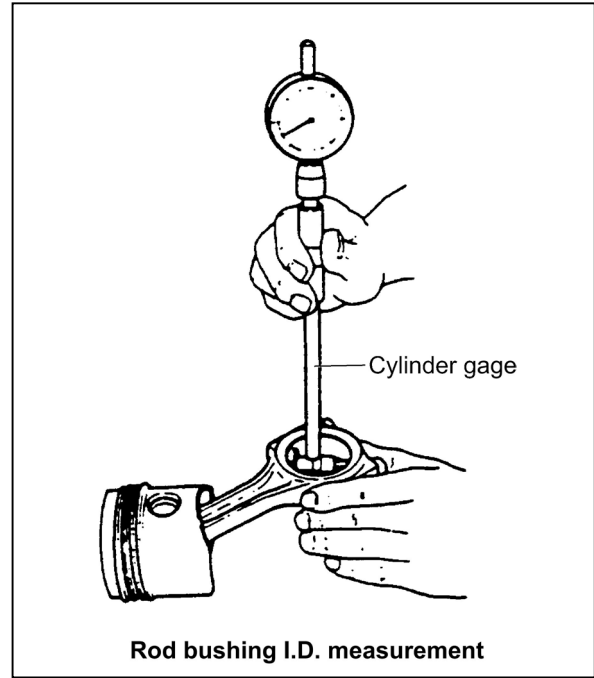

Tightening torque of rod bolt

Model	Tightening torque Nm(kgf-m)	Lubricating oil application (threaded portion, and bearing seat surface)
3TNV82A	37.2~41.2 (3.8~4.2)	Lube. oil applied
TNV84/88	44.1~49.0 (4.5~5.0)	
4TNV94L/98	53.9~58.8 (5.5~6.0)	
4TNV106(T)	78.5~83.4 (8.0~8.5)	

Standard of rod big end

mm

Model	Item	Standard	Limit
3TNV82A	Rod I.D. bushing	42.952~42.962	42.902
	Crankpin O.D.	43.000~43.042	-
	Metal thickness	1.487~1.500	-
	Clearance	0.038~0.090	0.150
TNV84/88	Rod I.D. bushing	47.952~47.962	47.902
	Crankpin O.D.	48.000~48.026	-
	Metal thickness	1.492~1.500	-
	Clearance	0.038~0.074	0.150
4TNV94L/98	Rod I.D. bushing	57.952~57.962	57.902
	Crankpin O.D.	58.000~58.026	-
	Metal thickness	1.492~1.500	-
	Clearance	0.038~0.074	0.150
4TNV106(T)	Rod I.D. bushing	63.952~63.962	63.902
	Crankpin O.D.	64.016~64.042	-
	Metal thickness	1.984~1.992	-
	Clearance	0.054~0.090	0.150

**(6) Tappet**

Mainly check the tappet contact surface with the cam and push rod. Slight surface defects shall be corrected with an oilstone.

**(a) Tappet stem outside diameter measurement**

Model	Item	Standard	Limit
TNV82A~88	Tappet hole I.D.	12.000~12.025	12.045
	Stem O.D.	11.975~11.990	11.955
	Clearance	0.010~0.050	0.090
4TNV94L·98	Tappet hole I.D.	12.000~12.018	12.038
	Stem O.D.	11.975~11.990	11.955
	Clearance	0.010~0.043	0.083
4TNV106(T)	Tappet hole I.D.	14.000~14.018	14.038
	Stem O.D.	13.966~13.984	13.946
	Clearance	0.015~0.052	0.092

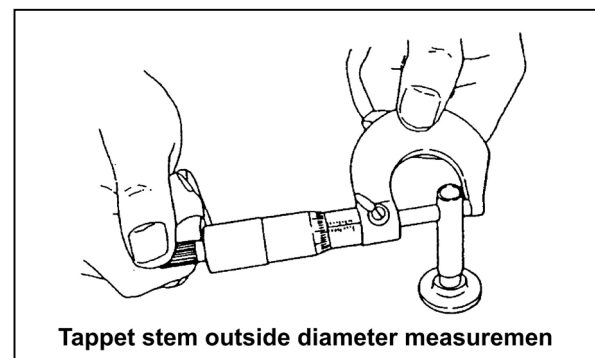
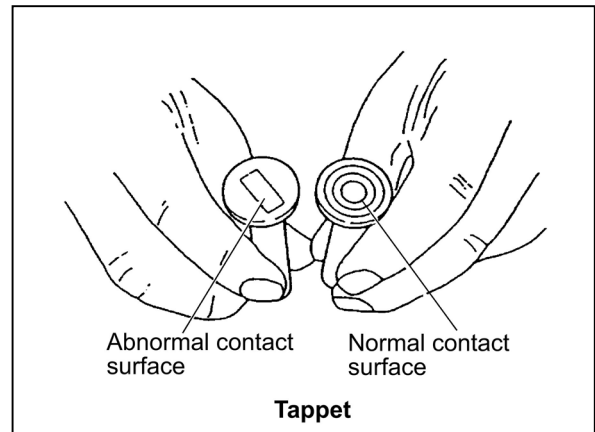

**4.4.6 Cylinder bore correction**

1) Slight uneven worn, flawed, etc. shall be corrected by honing only. If the cylinder is unevenly worn partially, flawed or otherwise damaged and cannot be repaired simply by honing, rebore the cylinder first and then hone. See 4.4.5.(1)(c) for the boring dimension.

2) Items to be prepared for honing

- Flex-Hone (see No.8 of 4.1.2 in Chapter 4)
- Electric drill
- Honing fluid (50:50 mixture of lube oil and diesel oil)

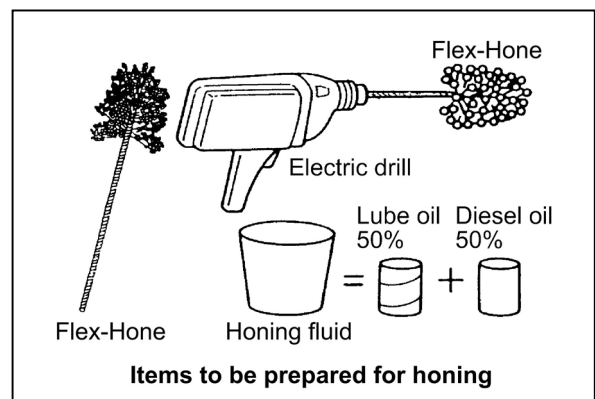

- 3) Apply the honing fluid to the Flex-Hone and turn the electric drill at 300 to 1200 rpm. Then insert the Flex-Hone into the cylinder bore while turning it, and move it up and down for about 30 sec. to obtain a honing mark with a cross hatch angle of 30 to 40°.

[NOTICE]

- 1) Avoid faster revolution than 1200 rpm since it may cause breakdown.
- 2) Do not insert or extract the Flex-Hone in stopped state because the cylinder will be damaged.

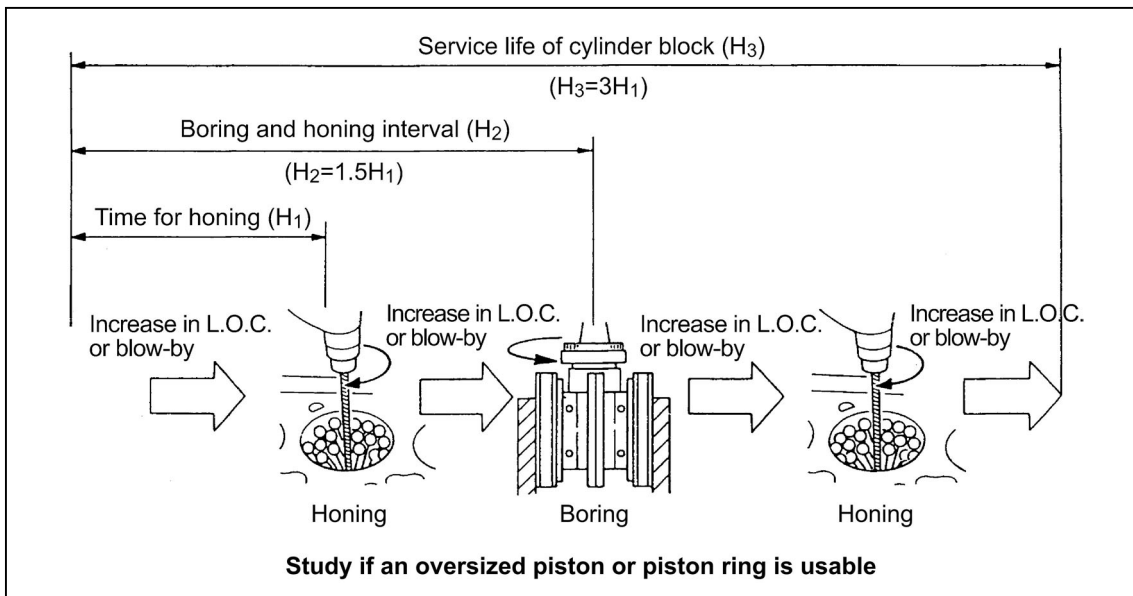
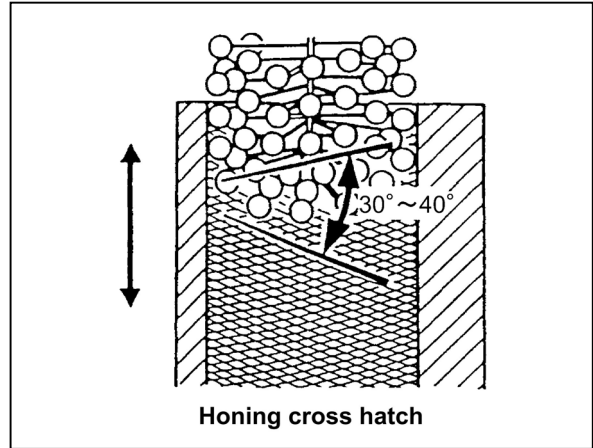

#### 4.4.7 Piston pin bushing replacement

Replace bushing by using the special service tool (see 4.1.2 No.3 in Chapter 4).

#### 4.4.8 Oil seal replacement (Flywheel housing side)

- 1) Replace oil seal, when a flywheel housing is removed. Extract the used oil seal.
- 2) Insert a new oil seal with the oil seal insertion tool.
- 3) Apply lithium grease.

## 5. LUBRICATION SYSTEM

### 5.1 Lubrication System Diagram

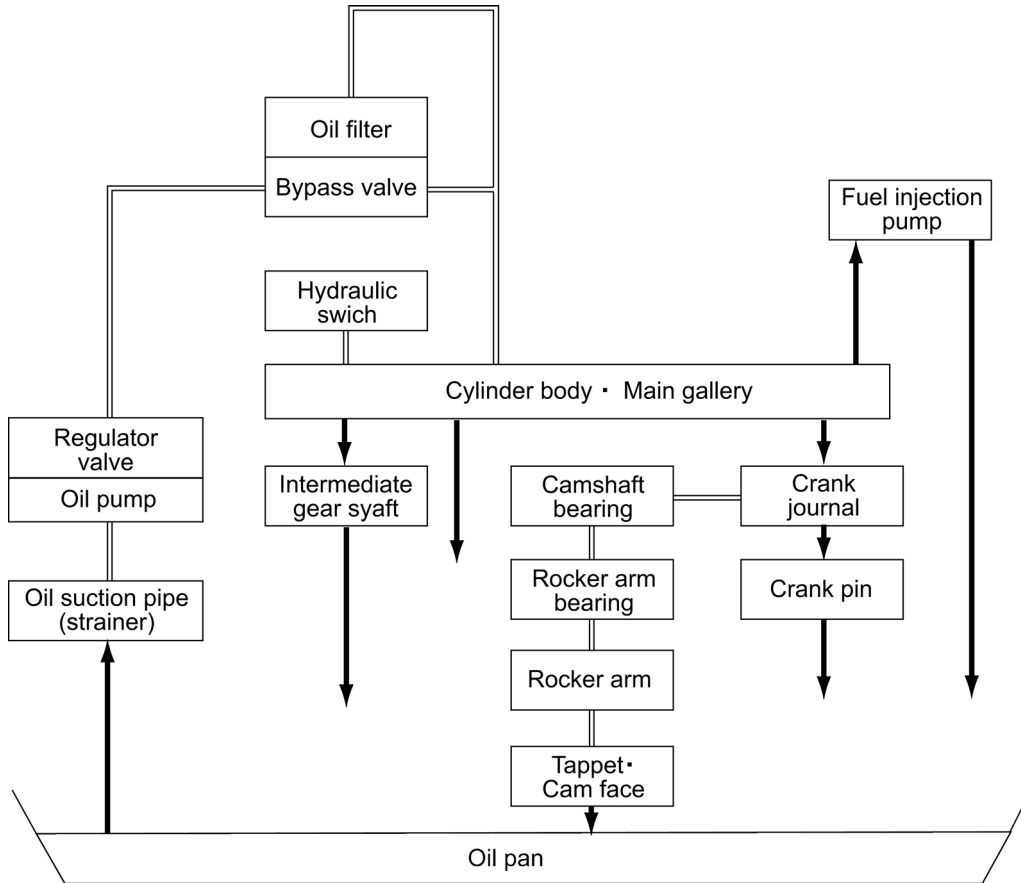

Note: It varies in the specifications of each model whether Oil cooler and Piston cooling of the \* mark are attached.

## 5.2 Trochoid Pump Components

Trochoid pump (3TNV82A~TNV88)

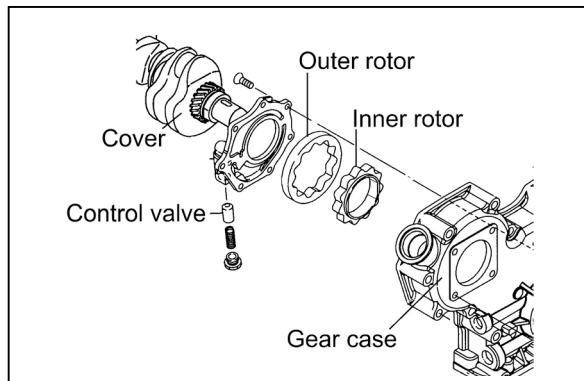

Trochoid pump (4TNV94L/98/106)

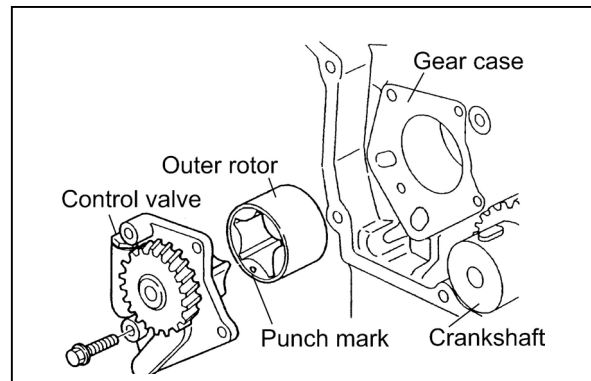

## 5.3 Disassembly(Reverse the procedure below for assembly)

- 1) Loosen the belt, and remove the radiator pulley, fan and V-belt. See 4.2.2. 2) in Chapter 4.
- 2) Remove the crankshaft pulley. See 4.3.2. 3) in Chapter 4.
- 3) Remove the gear case cover. See 4.3.2. 4) in Chapter 4.
- 4) Remove the lubricating oil pump assy from the gear case for 4TNV94/98/106. (5.4 Point 1)  
Remove the lube oil cover from gear case cover for 3TNV82A-88. (5.4 Point 1)
- 5) Remove the pressure regulating valve from the lubricating oil pump body. (5.4 Point 2)

## 5.4 Servicing Points

### Point 1

[Disassemble]

- Check if the pump rotates smoothly and see that there is no play between the shaft and gear, and inner rotor.

[Reassemble]

[NOTICE]

Always check if the pump rotates smoothly after installation on the gear case.

Running the engine when the pump rotation is heavy may cause the pump to be burnt.

#### 1) 3TNV82A-88

- Apply lube oil to rotor (outer/inner) insertion part.
- Assemble the outer rotor so that the mark of the end face may become a cover side when inserting it in the gear case.
- Fasten a lube oil pump cover by the standard torque.  
Tightening torque:  $6.9 \pm 1.5 \text{ N} \cdot \text{m}$  ( $0.7 \pm 0.15 \text{ kgf} \cdot \text{m}$ )
- When replacing the lube oil pump, replace the whole assy.

#### 2) 4TNV94L/98/106

- Apply lube oil to lube oil pump insertion part of gear case.
- Install the outer rotor in the gear case so that the punch mark on the end face is seen.
- When replacing the lube oil pump, replace the whole assy.

### Point 2

[Disassemble-Reassemble]

- Only wash the pressure regulating valve. Disassembly is unnecessary unless any abnormality in operation is detected.



## 5.5 Parts Inspection and Measurement

### 5.5.1 Trochoid pump inspection and measurement

#### (1) Outside clearance and side clearance of outer rotor

Insert a gap gage between a outer rotor and a pump body, and measure the clearance.

Outside clearance mm

Model	Standard	Limit
3TNV82A~88	0.12~0.21	0.30
4TNV94L/98	0.100~0.155	0.25
4TNV106(T)	0.100~0.165	0.25

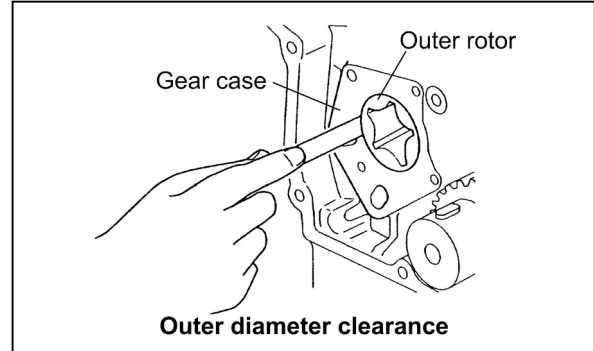

When measuring a side clearance, put a right-angle gage to the pump body, insert a gap gage and measure the clearance.

Side clearance mm

Model	Standard	Limit
3TNV82A~88	0.02~0.07	0.12
4TNV94L/98	0.05~0.10	0.15
4TNV106(T)	0.03~0.12	0.17

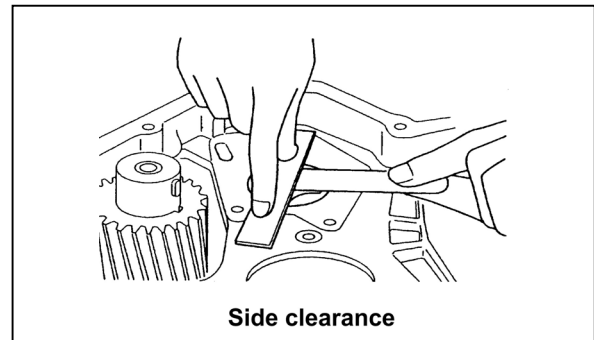

#### (2) Inner rotor and gear boss clearance (3TNV82A-4TNV88)

Item	Part	Standard dimension (mm)	Standard clearance (mm)	Standard clearance limit (mm)
Inside clearance of inner rotor	Gear boss diameter	53.05~53.15	0.3~0.5	0.6
	Rotor inner diameter	53.45~53.55		
Width across flat clearance of inner rotor	Width across flat of gear boss	49.45~49.75	0.2~0.6	0.7
	Width across flat of rotor	49.95~50.05		

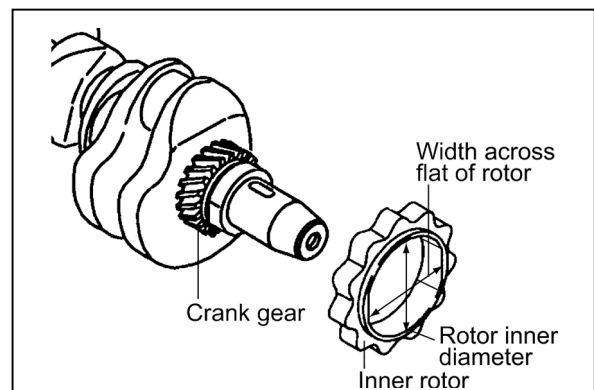

**(3) Rotor shaft clearance (4TNV94L/98/106)**

Measure the outside diameter of rotor shaft and the shaft hole diameter of gear case. Calculate the clearance from that difference.

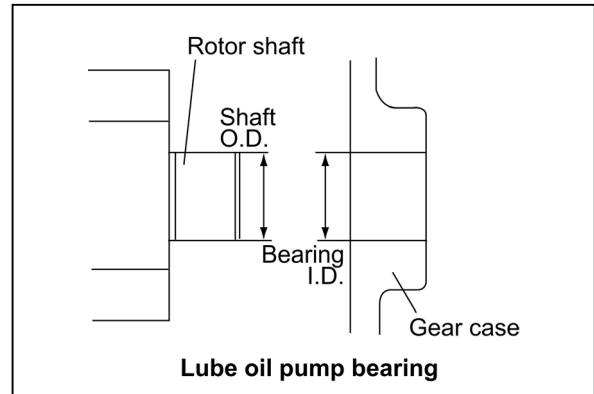

Model	Inspection item	Standard	Limit
4TNV94L/ 98	Gear case bearing I.D.	12.980~13.020	13.05
	Rotor shaft O.D.	12.955~12.970	12.945
	Rotor clearance	0.035~0.065	0.105
4TNV106(T)	Gear case bearing I.D.	13.000~13.020	13.05
	Rotor shaft O.D.	12.955~12.965	12.945
	Rotor clearance	0.035~0.065	0.105

## 6. COOLING SYSTEM

### 6.1 Cooling Water System

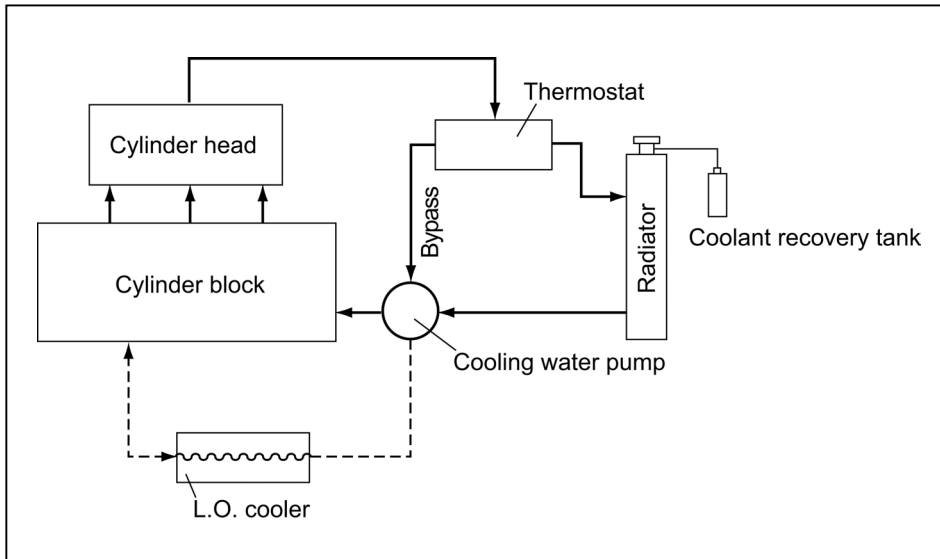

### 6.2 Cooling Water Pump Components

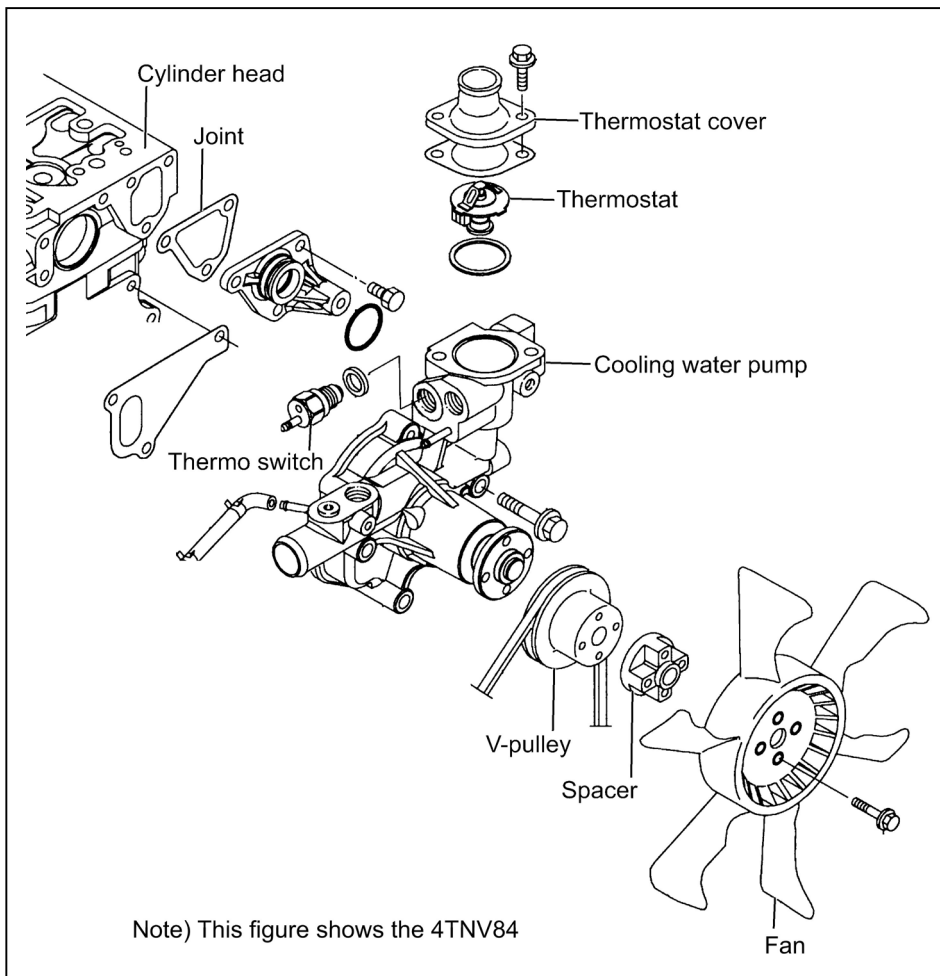

## 6.3 Disassembly (Reverse the procedure below for assembly)

- 1) Remove the alternator. See 4.2.2. 1) in Chapter 4.
- 2) Remove the fan, V-belt and pulley. See 4.2.2. 2) in Chapter 4.
- 3) Remove the cooling water pump. (Point 1, in below 6.4)
- 4) Remove the thermostat. (Point 2 in below 6.4)

## 6.4 Servicing Points

### Point 1

Disassemble-Reassemble:

- Check to see that the cooling water pump bearing is free from abnormal noise, sticking or play and water leakage from the bearing. If replacement is necessary, replace the whole cooling water pump assy.

### [NOTICE]

Replace the O-ring of the cooling water pump with new one when disassembling. And, be sure to use the special O-ring for each engine model, because the material is different, although the dimension is the same as a commercial part. (Refer to the right figure.)

### Point 2

Disassemble:

- Check the thermostat function. See 2.7 in Chapter 2 for the inspection method.

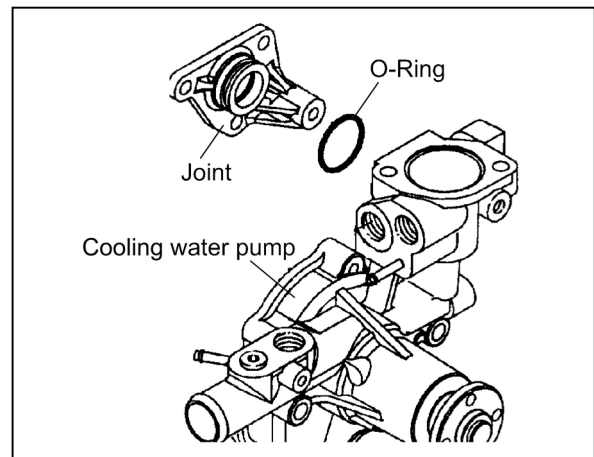

## 7. FUEL INJECTION PUMP/GOVERNOR

Only the outline of the MP fuel pump is explained in this chapter. Refer to the MP pump service manual of the separate volume for the disassembly and assembly.

### 7.1 Introduction

It is described about the features of the fuel injection pump, YDP-MP, manufactured by Yanmar, disassembly, assembly and adjustment procedure.

Fuel injection pump is the most important equipment, which is enable to make the sensitive adjustment according to the variable load of the engine.

Therefore all of the parts are required not only very precise machining but also finest, assembling with top level.

The careful arrangement of keeping off the dust and the rust when disassemble, adjustment and reassemble of the fuel injection pump is made in the market.

Yanmar YDP-MP Pump is a distributor type pump which is unified of Mono-plunger, a distributing shaft, a hydraulic head which equipped the delivery valve for each cylinder, pump housing which has a cam shaft internally and governor.

The fuel, which is pressurized by the up and down movement of the plunger driven by the cam-rotation, is supplied through the distributor shaft, which is rotating accordingly.

There are a model YDP-MP2 and a model YDP-MP4, and plunger diameter and fuel cam speed are different.

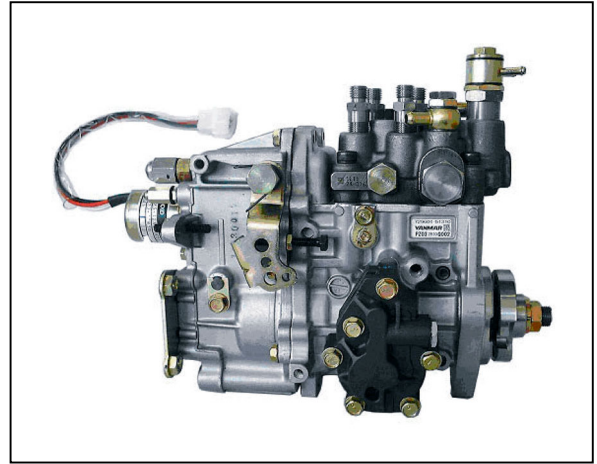

### 7.2 Fuel Injection Pump

#### 7.2.1 Fuel system diagram

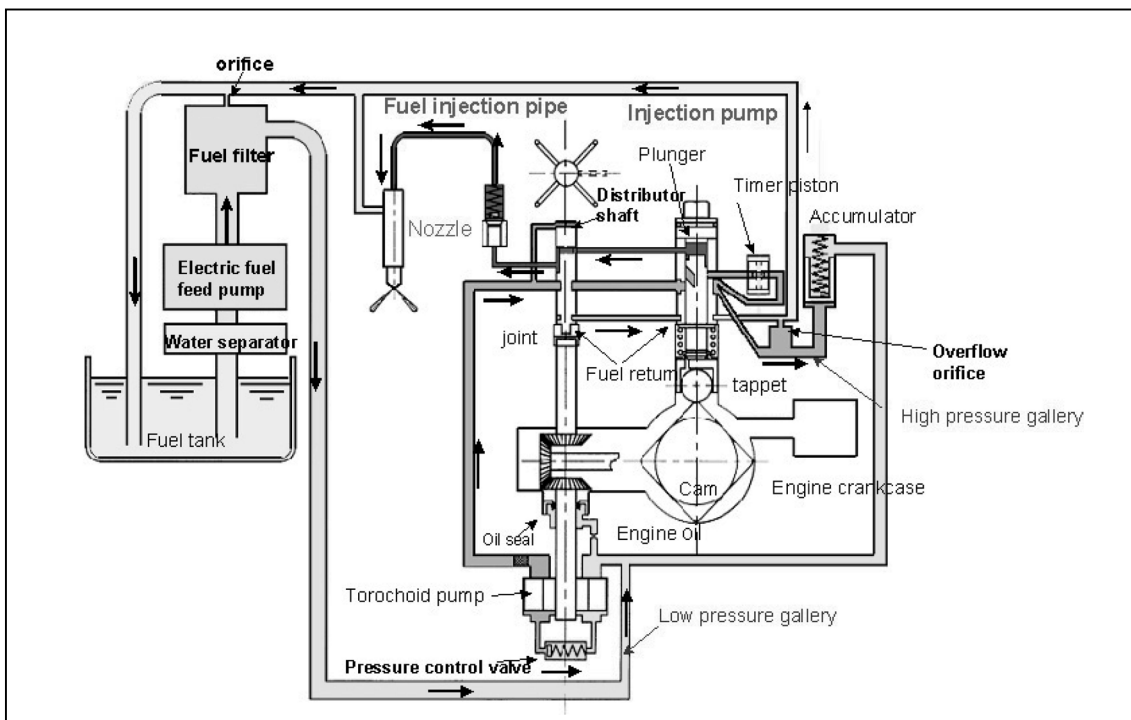

## 7.2.2 External view and components

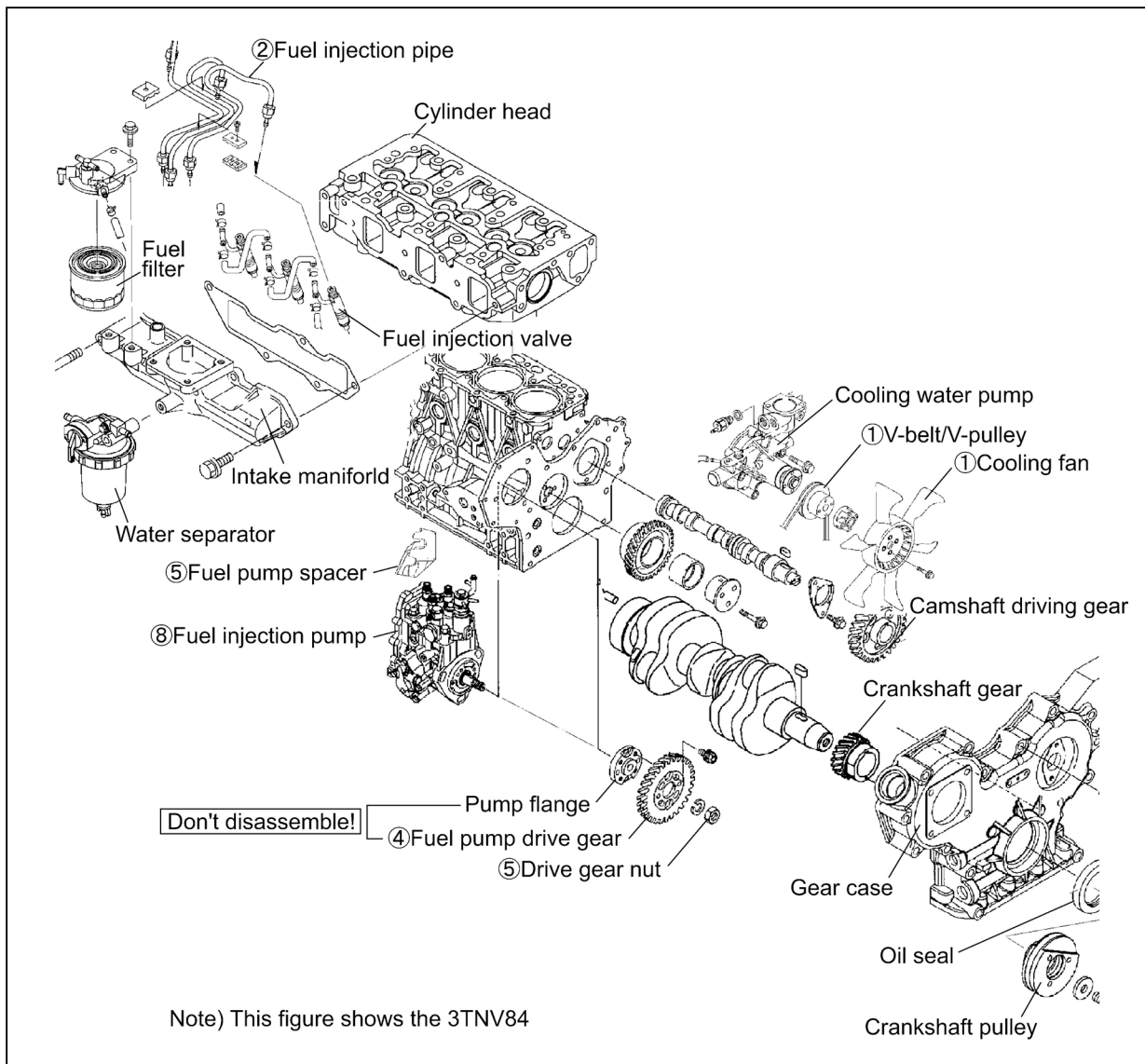

## 7.2.3 Disassembly procedure:

Disassembly from the engine body

- 1) Remove the cooling fan, pulley and V-belt.
- 2) Remove the fuel injection pipe, fuel oil piping, fuel return pipe and rear stay. See point 1 of 7.2.5.
- 3) Remove the fuel injection pump cover (the cover of the drive gear).
- 4) Make ID marks on the gearing part of the pump drive gear and the idle gear with paint and so on. See Point 2 of 7.2.5.
- 5) Loosen a fuel pump drive gear nut, and remove a pump drive gear from the fuel pump by using a gear puller. See Point 3 of 4.3.4.
- 6) Remove a drive gear nut carefully not to drop it to the inside of the gear case.
- 7) Record the installation angle of the fuel pump precisely by using a mark-off line and a sticker. See (4) of 2.2.7.
- 8) Remove the fuel injection pump. See Point 3 of 7.2.5.

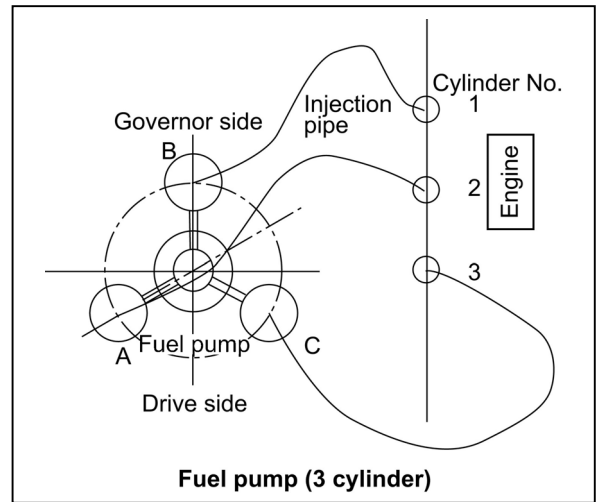
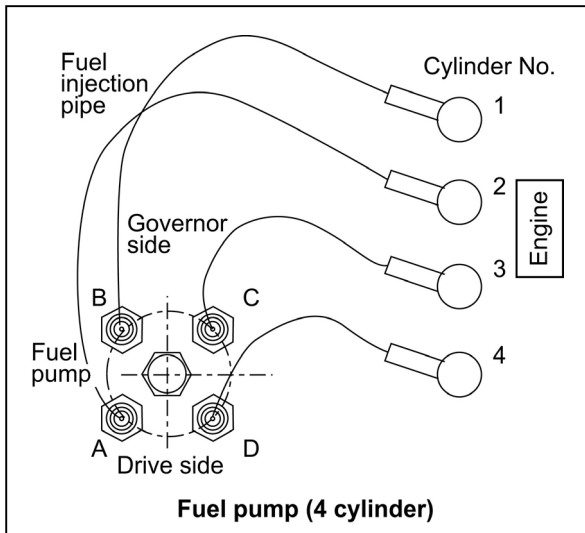

### 7.2.4 Assembly procedure

Reverse the disassembly procedure and adjust the fuel injection timing finally. See (4) of 2.2.7.

### 7.2.5 Servicing points

**Point 1**

[Disassemble]

- Block an entrance with the tape so that trash may not enter the fuel injection pipe and the fuel injection pump.

**Point 2**

[Disassemble]

- After putting the I.D. marks on the gearing part of the pump drive gear and the idle gear with paint and so on, remove the gear installation nut.

[NOTICE]

Don't remove four flange bolts.

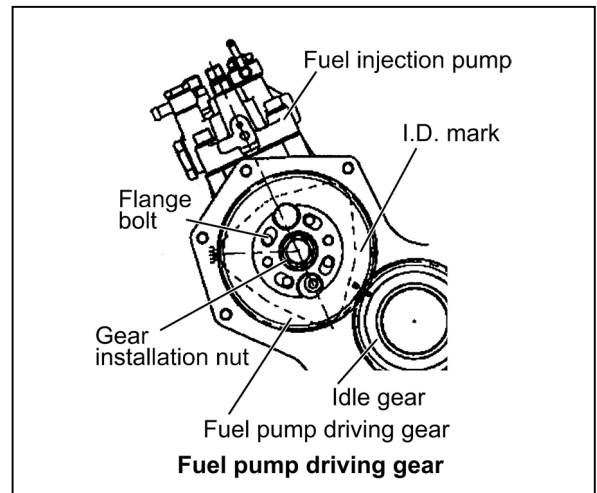

[Reassemble]

- Reassemble the pump driving gear while checking the I.D. marks on the driving gear and idle gear.

Tightening torque of the gear installation nut

Model	N·m(kgf·m)	Lubricating oil application (thread portion, and seat surface)
TNV82A~88	78~88 (8~9)	Not applied
4TNV94~106(T)	113~123 (11.5~12.5)	

**Point 3**

[Disassemble]

There is an acoustic material part to name as fuel pump spacer between the fuel pump and the cylinder block. Loosen fuel pump installation bolts with a closed wrench when disassembling a fuel pump.

[NOTICE]

An intake manifold may obstruct the disassembly of the fuel pump by the engine model. Remove the fuel pump after removing the intake manifold first.

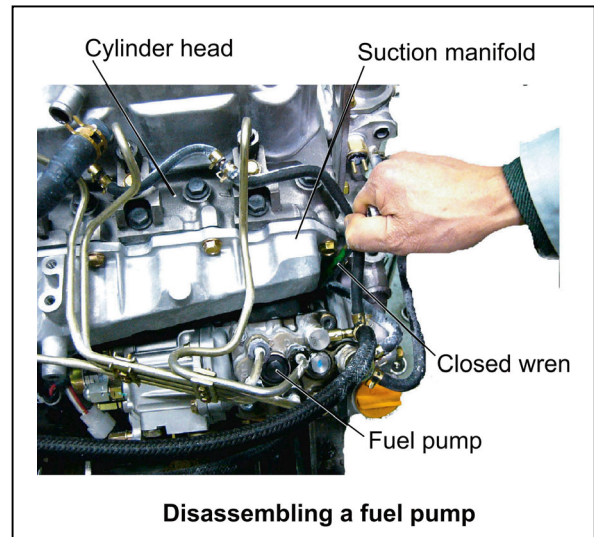
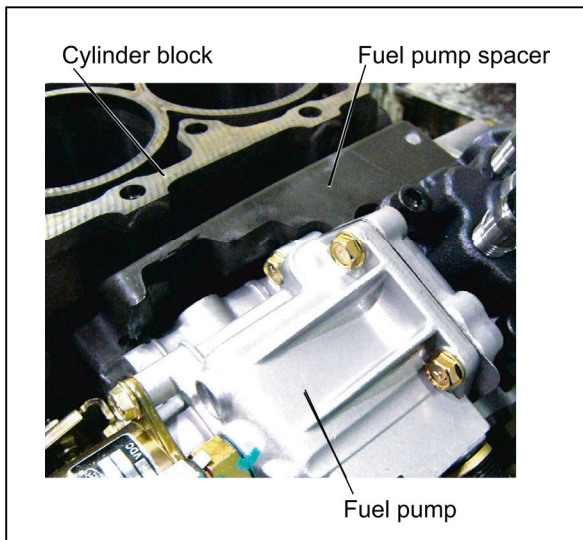

[Reassemble]

When installing a fuel pump on the gear case, put a fuel pump spacer between the cylinder blocks, and install it .



## 8. TURBOCHARGER: Disassembly, inspection and reassembly

### 8.1 Structure and Functions

#### 8.1.1 Main specifications

Applicable engine model (application)	3TNV84T(CL, VM) 4TNV84T(CL)	3TNV84T(VM)	4TNV106T(CL, VM)
Turbocharger model	RHB31	RHB51	RHF5
Turbocharger specification	Standard (w/waste gate)		
Turbine type	Radial flow		
Blower (compressor) type	Centrifugal		
Lubrication method	External lubrication		
Max. continuous allowable speed	250,000	180,000	
Max. continuous allowable gas inlet temperature	750		
Dry weight N(kgf)	24(2.4)	41(4.2)	46(4.7)

Note) VM application is provided with the waste gate.

#### 8.1.2 Construction

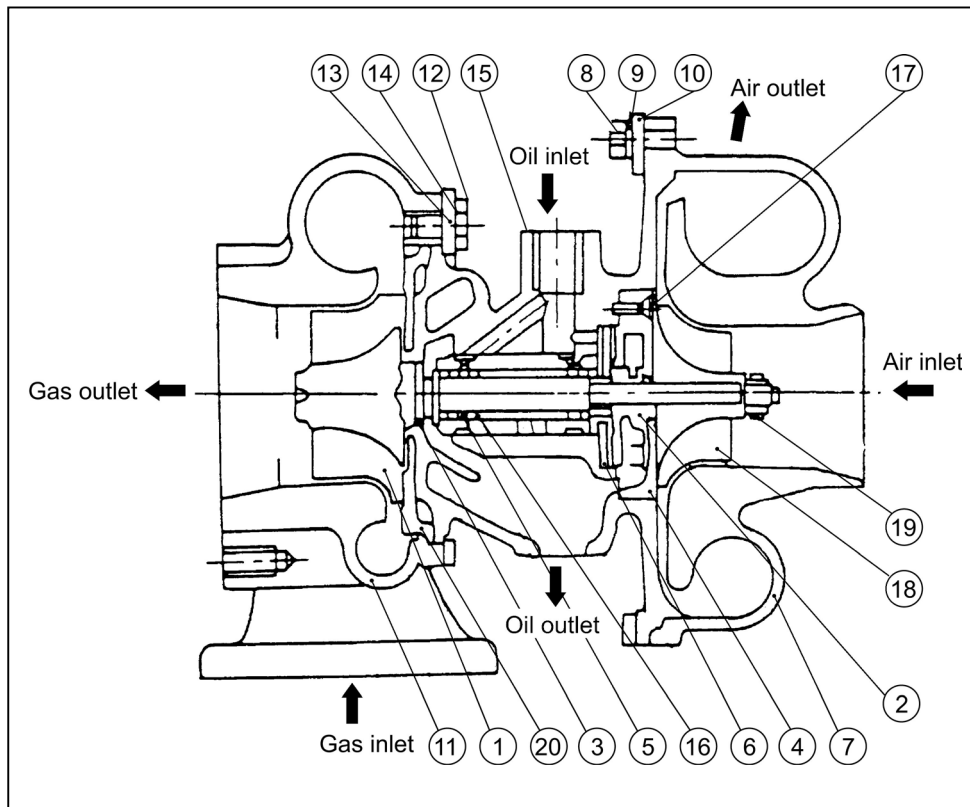

### 8.1.3 Structural and functional outline

No.	Part name
1	Turbine shaft
2	Oil thrower
3	Turbine side seal ring
4	Seal plate
5	Journal bearing
6	Thrust bearing
7	Compressor housing
8	M5 hexagon bolt
9	M5 spring washer
10	Compressor side clamp
11	Turbine housing
12	M6 hexagon bolt
13	Turbine side clamp
14	Lock washer
15	Bearing housing
16	Retaining ring
17	M3 countersunk flat head screw
18	Compressor wheel
19	Shaft end nut
20	Heat protector

#### (1) Turbine

The exhaust gas from the engine is accelerated at the nozzle portion in the turbine housing and blown onto the turbine impeller to rotate the turbine shaft.

This is called the turbine. A seal ring and heat insulating plate are installed to prevent the bearing from adverse influence of the gas.

#### (2) Compressor

The compressor impeller installed on the turbine shaft rotates with the shaft to suck and compress air for feeding into the intake manifold.

This is called the blower or compressor.

#### (3) Bearings

##### **Thrust bearing**

As the turbine shaft is constantly applied with a thrust force, this bearing prevents the shaft from being moved by the thrust force.

##### **Radial bearing**

A floating bearing is adopted. Since the bearing moves with the turbine shaft as the oil films are formed both inside and outside the bearing, the bearing sliding speed is slower than the turbine shaft speed, resulting in higher dynamic stability.

#### (4) Compressor side sealing mechanism

To prevent the intake air and oil from leaking, a seal ring and a seal plate are provided to form a double wall structure on the rear side of the compressor impeller.

#### (5) Waste gate

When the blower side pressure (intake air pressure) exceeds the specified level, the exhaust gas at the turbine inlet is partially bypassed to the exhaust discharge side to control the turbine rpm so as to maintain the intake pressure at the specified level for improving the response to load variation in the low to medium speed range and to minimize black smoke generation. It consists of a control assembly separated from the turbocharger and a valve assembly installed in the turbine impeller chamber.

### 8.1.4 Components

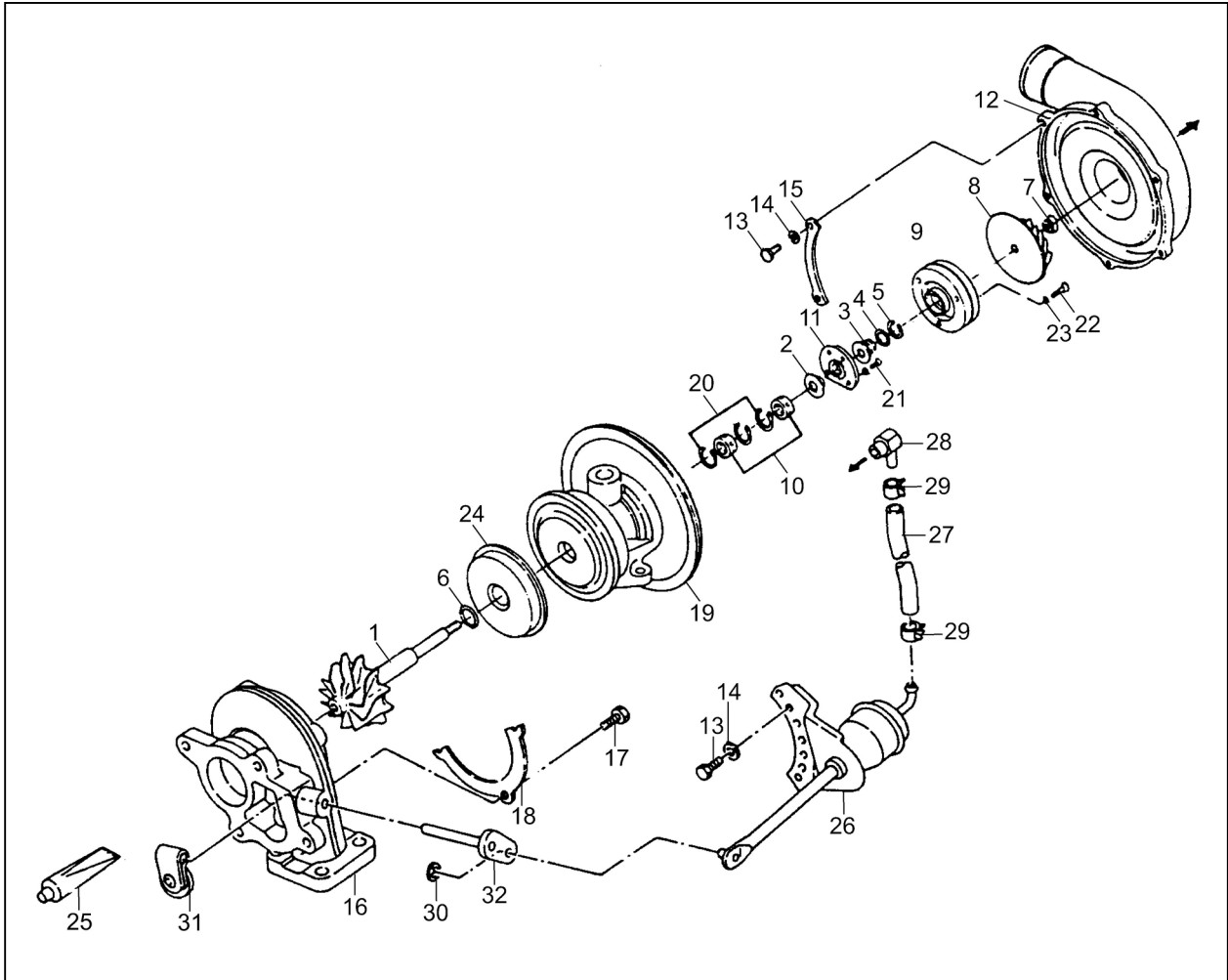

No.	Part name	No.	Part name
1	Turbine shaft	17	Bolt
2	Thrust bushing	18	Lock plate
3	Oil thrower	19	Bearing housing
4	Seal ring	20	Retaining ring
5	Seal ring	21	Screw
6	Seal ring (turbine side)	22	Screw
7	Lock nut	23	Lock washer
8	Impeller	24	Heat protector
9	Seal plate	25	Liquid gasket
10	Journal bearing	26	Waste gate actuator
11	Thrust bearing	27	Hose
12	Compressor housing	28	Adapter
13	Flanged bolt	29	Clip
14	Spring washer	30	Retaining ring
15	Clamp	31	Waste gate valve
16	Turbine housing	32	Link plate

## 8.2 Service Standards and Tightening Torque

### 8.2.1 Service standards

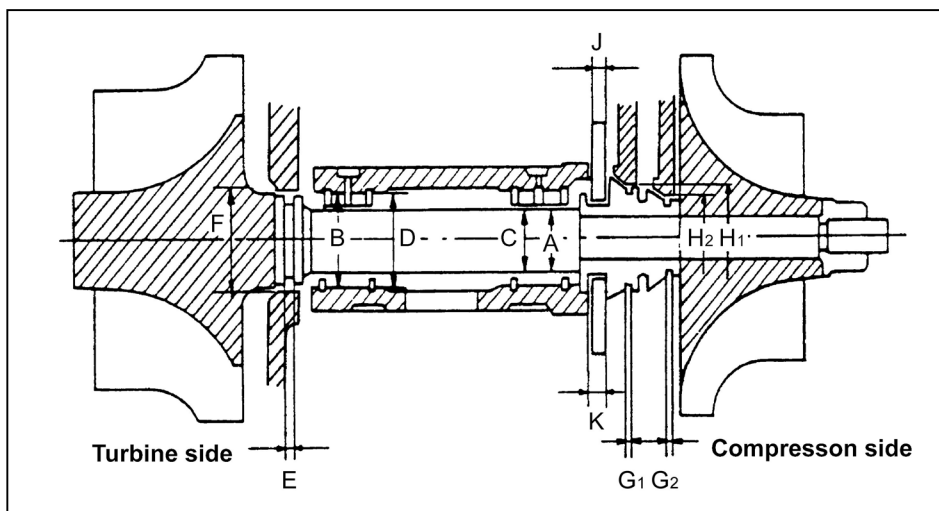

#### (1) RHF5 type

Unit: mm

		Standard dimension	Wear limit
Turbine shaft	Turbine shaft journal outside diameter (A)	7.99~8.00	7.98
	Turbine shaft seal ring groove width (E)	1.25~1.28	1.29
	Compressor side seal ring groove width (G1)	1.22~1.23	1.31
	Compressor side seal ring groove width (G2)	1.02~1.03	1.11
	Turbine shaft run-out	0.002	0.011
Bearing	Journal bearing inside diameter (C)	8.01~8.03	8.04
	Journal bearing outside diameter (D)	12.32~12.33	12.31
	Bearing housing inside diameter (B)	12.40~12.41	12.42
Thrust bearing	Thrust bearing width (J)	3.99~4.01	3.98
	Thrust bushing groove dimension (K)	4.04~4.05	4.07
Seal ring fixing area	Turbine side (bearing housing)(F)	15.00~15.02	15.05
	Compressor side (seal ring)(H1)	12.40~12.42	12.45
	Compressor side (seal ring)(H2)	10.00~10.02	10.05
Rotor play in axial direction		0.03~0.06	0.09
Rotor play in radial direction		0.08~0.13	0.17

## (2) RHB31/RHB51 type

Unit: mm

		Standard dimension		Wear limit	
		RHB31	RHB51	RHB31	RHB51
Turbine shaft	Turbine shaft journal outside diameter (A)	6.257~6.263	7.99~8.00	6.25	7.98
	Turbine shaft seal ring groove width (E)	1.038~1.062	1.25~1.28	1.07	1.29
	Compressor side seal ring groove width (G1)	1.02~1.03	1.22~1.23	1.04	1.31
	Compressor side seal ring groove width (G2)	0.82~0.83	1.02~1.03	0.84	1.11
	Turbine shaft run-out	0.002	0.002	0.005	0.011
Bearing	Journal bearing inside diameter (C)	6.275~6.285	8.01~8.03	6.29	8.04
	Journal bearing outside diameter (D)	9.940~9.946	12.32~12.33	9.93	12.31
	Bearing housing inside diameter (B)	9.995~10.005	12.40~12.41	10.01	12.42
Thrust bearing	Thrust bearing width (J)	3.59~3.61	3.99~4.01	3.58	3.98
	Thrust bushing groove dimension (K)	3.632~3.642	4.04~4.05	3.65	4.07
Seal ring fixing area	Turbine side (bearing housing)(F)	11.00~11.018	15.00~15.02	11.03	15.05
	Compressor side (seal ring)(H1)	9.987~10.025	12.40~12.42	10.04	12.45
	Compressor side (seal ring)(H2)	7.968~8.00	10.00~10.02	8.01	10.05
Rotor play in axial direction		0.022~0.053	0.03~0.06	0.07	0.09
Rotor play in radial direction		0.061~0.093	0.08~0.13	0.12	0.17

## 8.2.2 Tightening torque

## (1) RHF5 type

N·m(kgf·cm)

Part	Thread diameter	Tightening torque
Turbine housing set bolt	M8	27~29 (275~295)
Compressor housing set bolt	M5	4.2~5.2 (43~53)
Thrust bearing set screw	M3	1.2~1.4 (12~14)
Seal plate set screw	M3	1.2~1.4 (12~14)
Blower impeller set nut (left-handed screw)	M5	1.8~2.2 (18~22)

## (2) RHB31/ RHB51 type

N·m(kgf·cm)

Part	Thread diameter	Tightening torque	
		RHB31	RHB51
Waste gate actuator set bolt	M5	3.9~4.9 (40~50)	3.9~4.9 (40~50)
Lock plate set bolt	M6	11.8~12.8 (120~130)	11.8~12.8 (120~130)
	M8	11.8~12.8 (120~130)	27.0~28.9 (275~295)
Thrust bearing set screw	M3	1.2~1.4 (12~14)	1.2~1.4 (12~14)
Seal plate set screw	M3	1.2~1.4 (12~14)	1.2~1.4 (12~14)
Blower impeller set nut (left-handed screw)	M5	0.9~1.1 (9~11)	1.8~2.2 (18~22)

## 8.3 Periodic Inspection Procedure

### 8.3.1 Periodic inspection intervals

Periodically inspect the turbocharger for the overall conditions and fouling.

The inspection interval varies with the operating conditions, but refer to the table below for the guideline for each application.

Application	Inspection interval		
For vehicles (automobiles)	Every 6 months or 60,000km	Every 12 months or 150,000km	Every 24 months or 300,000km
For construction machinery	Every 6 months or 500hrs	Every 12 months or 1,000hrs	Every 24 months or 2,000hrs
For farming machinery	Every 6 months or 200hrs	Every 12 months or 400hrs	Every 24 months or 800hrs
For marine use	Every 6 months or 1,500hrs	Every 12 months or 3,000hrs	Every 24 months or 6,000hrs
Rotor rotation	○		
Rotor play		○	
Overhaul and overall inspection			○
Oil filter cleaning and inspection	Based on engine operation manual		
Engine oil replacement			

### 8.3.2 Inspection procedure

#### (1) Rotor rotation inspection

Inspect the rotor rotation by listening to any abnormal sound generation during rotation.

For inspection with a sound detecting bar, bring the tip end of the bar into strong contact with the turbocharger case and raise the engine speed gradually.

If any high pitch sound is generated at intervals of 2 to 3 seconds, the rotation is abnormal. Since the bearing or rotor may be defective in this state, either replace or overhaul the turbocharger.

#### (2) Rotor play inspection

Remove the turbocharger from the engine and inspect the rotor play in the axial and radial directions according to the procedure below.

After removing the turbocharger from the engine, always bind the oil inlet and outlet holes with adhesive tape.

Rotor play in axial direction

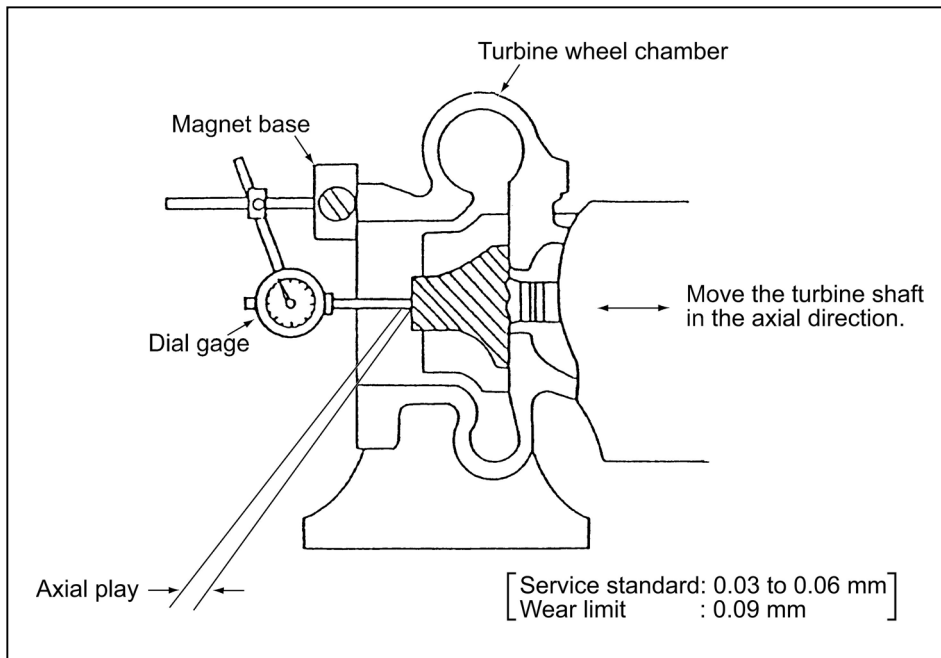

### 8.3.3 Waste gate valve adjustment procedure

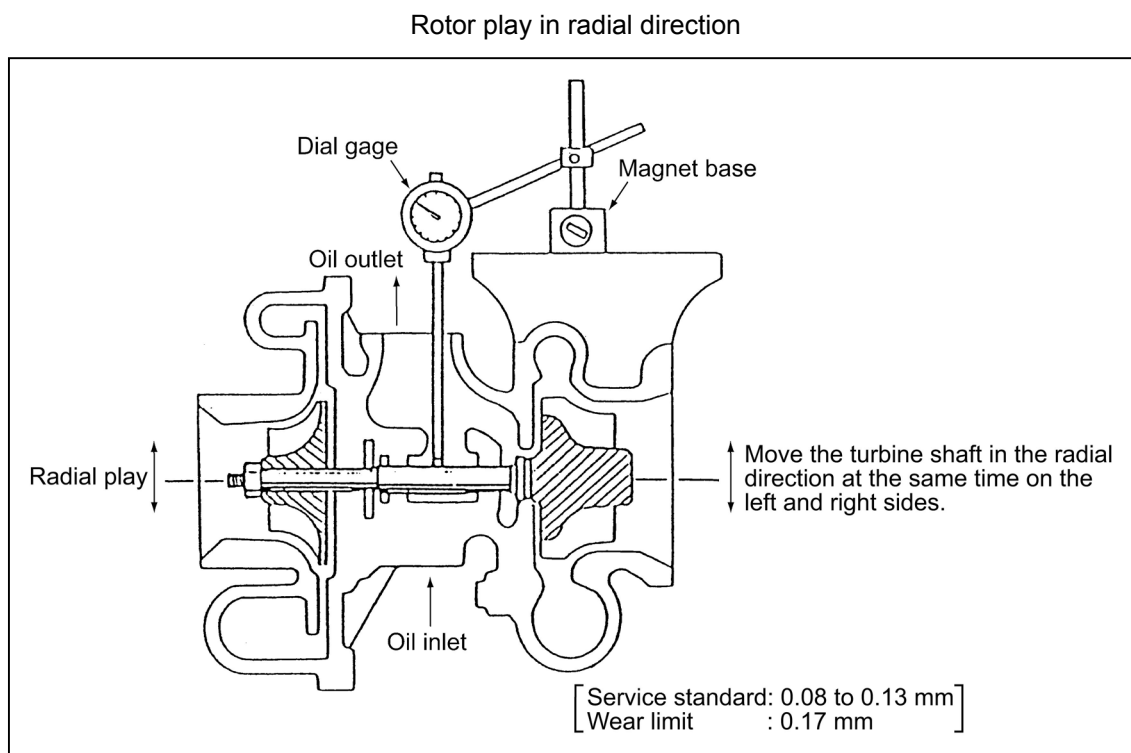

It is indispensable to adjust the waste gate valve opening pressure and lift after its overhaul or inner parts replacement. Negligence of this adjustment will adversely affect the engine performance.

**[NOTICE]**

If the adjustment is impossible, give up overhaul but replace the whole turbocharger assembly.

**(1) Method for checking the waste gate valve opening pressure and lift**

**(a) Equipment**

Prepare the equipment shown in the figure below.



## (b) Measuring instruments and devices

Dial gage	Capable of measuring 0 to 10 mm (A flat head type is recommendable.)
Manometer	Mercury column or electrical type (capable of measuring 0 to 1500 mmHg)
Pressure regulating valve	Allowing gradual adjustment in a range between 0 and 2 kgf/cm <sup>2</sup> (0.196 Mpa)
Pressure reducing valve	Used for suppressing the air supply pressure at 5 kgf/cm <sup>2</sup> (0.49 Mpa) or less.
Pressure gage	Bourdon tube pressure gage (0 to 10 kgf/cm <sup>2</sup> (0.98 Mpa))

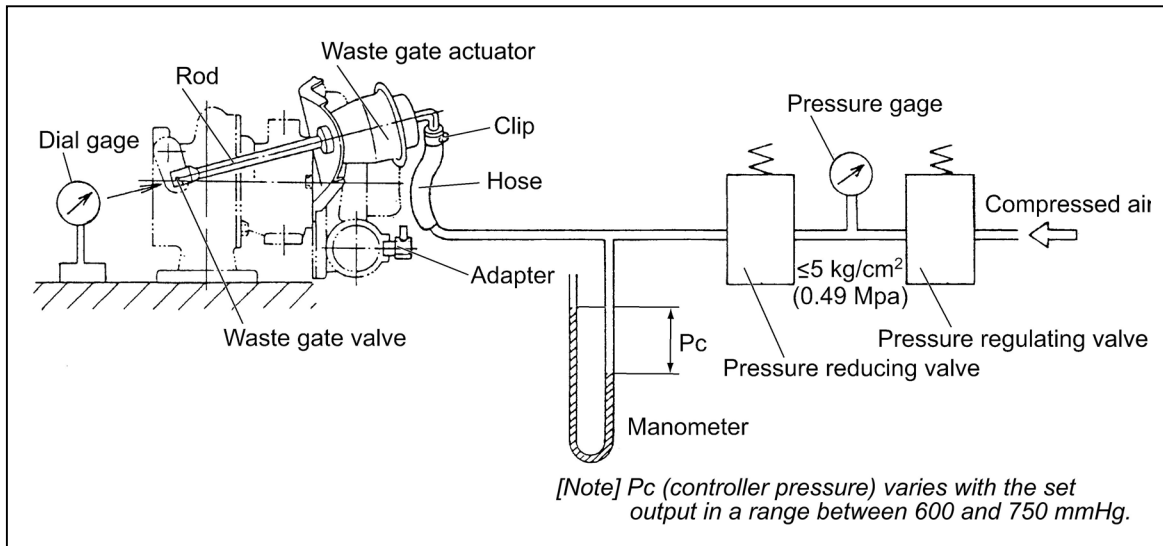

## (c) Check method

- 1) Set the manometer control pressure ( $P_c$ ) applied to the waste gate actuator to 0 and set the dial gage to the zero point.
- 2) Gradually open the pressure regulating valve and measure the  $P_c$  value when the actuator rod is operated by 2 mm.
- 3) For the hysteresis, let the rod move to 3 mm first. The gradually close the pressure regulating valve, measure the pressure when the rod is moved to 2mm and obtain the difference from the pressure measured in b. above.
- 4) Precautions
  - Set the dial gage on the extension line of the actuator rod.
  - The piping and joints shall completely be free from leak.
  - Fix the turbocharger and dial gage securely.
  - If an electric manometer is used, it shall have sufficient precision.
  - Even when an electric manometer is used, use of a mercury column type manometer in combination is recommended for calibration and daily check.
  - The speed for increasing/decreasing  $P_c$  by means of the pressure regulating valve shall be very slow near the measuring point. If the mm position is exceeded, restart from the beginning.
  - Do not apply over 0.49 MPa (5 kgf/cm<sup>2</sup>) to the actuator.

## (2) Waste gate actuator leak test

Apply 0.12 Mpa (1.2kgf/cm<sup>2</sup>) to the actuator and hold the state for minute. The actuator is good if the pressure then is 0.11 Mpa (1.1kgf/cm<sup>2</sup>) or above.

## 8.4 Disassembly Procedure

### 8.4.1 Preparation for disassembly

In addition to the general tools, the following special tools are required for turbocharger disassembly and reassembly:

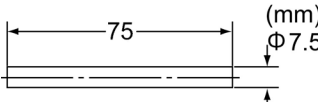
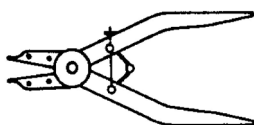
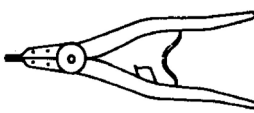
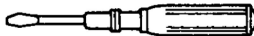
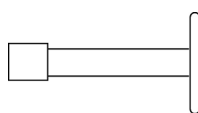
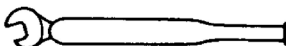
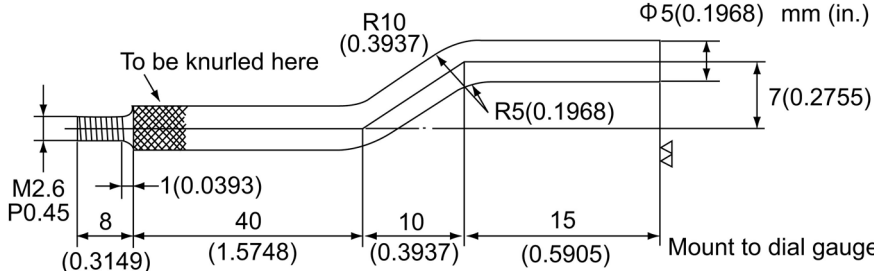
Tool name	Use	Illustration
Bar	For removing thrust bearing and thrust bushing	 <p>(mm) <math>\Phi 7.5</math></p> <p>Material: Copper or brass</p>
Pliers	For removing floating bearing circlip	
Pliers	For removing seal ring	
Torque driver for TORX bolt (multifunctional type) 0.5 to 4.9N-m (5 to 50 kgf-cm)	For thrust bearing installation (for M3):1.3 N-m (13 kgf-cm)  For seal plate installation (for M3):1.3 N-m (13 kgf-cm)	<p>Item sold on market</p>  <p>(Type: TORX TT20 or equivalent)</p>
Box wrench	For fixing turbine shaft (mmxdodecagonal)	 <p>Box only may be used.</p>
Torque wrench (single purpose)	For following bolts and nuts: M8:mm, kgf-cm(N-m) M5:mm, kgf-cm(N-m) M5:mm, kgf-cm(N-m)	
Probe	For measuring play in axial and radial directions: To be installed on a dial gage	 <p><math>\Phi 5(0.1968)</math> mm (in.)</p> <p>To be knurled here</p> <p>R10 (0.3937)</p> <p>R5(0.1968)</p> <p>7(0.2755)</p> <p>M2.6 P0.45</p> <p>8 (0.3149)</p> <p>1(0.0393)</p> <p>40 (1.5748)</p> <p>10 (0.3937)</p> <p>15 (0.5905)</p> <p>Mount to dial gauge</p>

### 8.4.2 Inspection before disassembly

- 1) Inspect the turbine wheel and compressor impeller for any undesirable contact and the rotor for smooth rotation.
- 2) Measure the rotor play as described in section 8.3(2.2).
  - Rotor axial play   Wear limit: mm
  - Rotor radial play   Wear limit: mm

### 8.4.3 Disassembly

The mounting angles of the turbine housing, bearing housing and compressor housing are determined according to its mounting state on the engine. Put match marks before starting disassembly.

Note: The number after each part is the one described in the structural drawing in 8.1(2).

#### (1) Compressor housing removal

- 1) Remove flanged hexagon bolt 8 and compressor side keep plate 10.
- 2) Remove compressor housing 7.

Note:

- 1) Liquid gasket is applied on the surface of compressor housing 7 where bearing housing 15 is mounted.
- 2) When disassembling compressor housing 7, carefully operate so as not to damage the compressor impeller.

#### (2) Compressor impeller removal

- 1) Set a box spanner (10mm) on the turbine side end of the turbine shaft, and remove shaft end clamp 18.

Note: Pay attention to the loosening direction since the shaft end nut has left-handed screw.

- 2) Remove compressor impeller 18.

#### (3) Turbine housing removal

- 1) Remove hexagon nut 12 and turbine side keep plate 13.
- 2) Remove turbine housing 11.

#### (4) Turbine shaft extraction

- 1) Hold heat insulating plate 20 lightly with a hand, and extract turbine shaft 1.

Note: If the turbine shaft is hard to be extracted, tap the compressor side end of the shaft lightly with a wooden hammer.

- 2) Remove heat insulating plate 20.

#### (5) Seal plate removal

- 1) Use the Torx driver and loosen M3 Torx T-type machine screw 17 for seal plate mounting.
- 2) Remove seal plate 4.

Note: Liquid gasket has been applied to the seal plate and bearing housing mounting surface.

- 3) Remove oil thrower 2 from the seal plate.

#### (6) Slide bearing and thrust bushing removal

- 1) Use the Torx driver and loosen the M3 Torx T-type machine screw for thrust bearing installation.
- 2) Use the bar (copper) and remove thrust bearing 6 and thrust bushing.

(7) Floating bearing removal

- 1) Use the stop ring pliers and remove circlip 16 from bearing housing 15.
- 2) Remove floating bearing 5 from bearing housing 15.

(8) Seal ring removal

- 1) Remove turbine side seal ring 3 from turbine shaft 1.
- 2) Remove compressor side seal ring (small) and compressor side seal ring (large) from oil thrower 2.

## 8.5 Washing and Inspection procedure

### 8.5.1 Washing

#### (1) Inspection before washing

Visually inspect each part before washing to check trace of seizure, wear, foreign matter or carbon adhesion.

Carefully inspect for identifying the cause of trouble especially when a fault has occurred.

Major inspection items

Check point	Checking position
Carbon adhesion state	1) Turbine shaft 1, turbine side seal ring and rear side of turbine wheel 2) Heat insulating plate 20 mounting portion and inside of bearing housing 15
Lubrication status (wear, seizure, discoloration, etc.)	1) Turbine shaft 1, journal portion and thrust bushing oil thrower 2 2) Floating bearing 5 and thrust bearing 6 3) Bearing housing 15 and inner wall of bearing fitting ring
Oil leak state	1) Inner wall of turbine housing 11 2) Outer surface of bearing housing 11 and heat insulating plate 20 mounting portion 3) Turbine shaft 1 turbine side seal ring portion and rear side of turbine wheel 4) Inner wall of compressor housing 7 5) rear side of compressor impeller 18 6) Surface and seal ring inserting portion of seal plate 4

#### (2) Washing procedure

Keep the following in mind when washing the parts.

Part	Tools and detergent	Procedure
a) Turbine shaft	<ul style="list-style-type: none"> <li>● Tools</li> <li>1) Bucket(500x500)</li> <li>2) Heat source: Steam or gas burner</li> <li>3) Brush</li> <li>● Detergent</li> <li>Standard carbon removing agent</li> </ul>	<ol style="list-style-type: none"> <li>1) Boil the turbine in the washing bucket. Do not strike the blade to remove the carbon.</li> <li>2) Immerse in the detergent until the carbon and other deposits are softened.</li> <li>3) Use a plastic scraper or hand hair scrubber to remove the softened deposits.</li> <li>4) Protect the bearing surface and seal ring groove on the turbine shaft so as not to be damaged.</li> <li>5) Any deposit remaining on the turbine shaft due to improper washing may cause unbalancing. Be sure to remove thoroughly. Never use a wire brush.</li> </ol>
b) Turbine wheel chamber	<ul style="list-style-type: none"> <li>● Tools</li> <li>Same as for turbine shaft</li> <li>● Detergent</li> <li>Same as for turbine shaft</li> </ul>	<ol style="list-style-type: none"> <li>1) Boil the turbine in the washing bucket.</li> <li>2) Immerse in the detergent until the carbon and other deposits are softened.</li> <li>3) Use a plastic scraper or hard hair scrubber to remove the softened deposits.</li> </ol>
c) Blower blade and chamber	<ul style="list-style-type: none"> <li>● Tools</li> <li>1) Bucket(500x500)</li> <li>2) Brush</li> <li>● Detergent</li> </ul>	<ol style="list-style-type: none"> <li>1) Immerse in the washing bucket until the deposit is softened.</li> <li>2) Use a plastic scraper or hard hair scrubber to remove the softened deposits.</li> <li>Never use a wire brush.</li> </ol>
d) Others	<ol style="list-style-type: none"> <li>1) Wash all other parts with diesel oil.</li> <li>2) Clean the lubricating oil path by blowing with compressed air.</li> <li>3) Be especially careful so as not to damage or corrode the parts.</li> </ol>	

## 8.5.2 Inspection procedure

### (1) Compressor housing 7

Inspect the compressor housing for any contact trace with the compressor impeller, surface defect, dent or crack at joint surface, and replace it if defective.

### (2) Turbine housing 11

Inspect any trace of contact with the turbine wheel, exfoliation due to degradation by oxidation of the cast surface, thermal deformation or crack.

Replace with a new one if defective.

### (3) Compressor impeller 18

Inspect any contact trace, chipping, corrosion or deformation.

Replace with a new one if defective.

### (4) Turbine shaft 1

1) Inspect any contact trace, chipping, thermal discoloration or deformation at the turbine wheel. Check the shaft portion for bend, the journal portion for thermal discoloration or abnormal wear, and the seal ring groove for surface defect or wear. Replace with a new one if defective.

2) Measure the turbine shaft journal outside diameter (A) and seal ring groove width (E). Replace with a new turbine shaft if beyond the wear limit.

#### **Wear limit of journal outside diameter (A)**

RHF5 ..... 7.98mm

RHB51 ..... 7.98mm

RHB31 ..... 6.25mm

#### **Wear limit of ring groove width (E)**

RHF5 ..... 1.29mm

RHB51 ..... 1.29mm

RHB31 ..... 1.07mm

3) Measure the turbine shaft run-out, and replace with a new turbine shaft if it exceeds 0.011 mm.

### (5) Heat insulating plate 20

Inspect the heat insulating plate for any contact trace, thermal deformation or corrosion. Replace with a new one if defective.

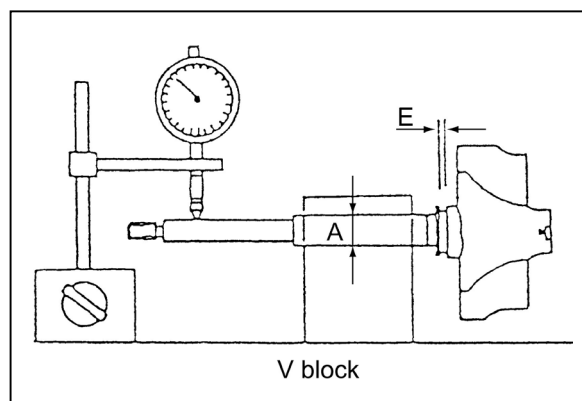

(6) Thrust bushing, oil thrower 2 and thrust bearing 6 Inspect each part for wear, surface defect and discoloration.

Replace with a new one if defective even within the wear limit.

(a) Thrust bushing

Measure the distance between grooves (K) of the thrust bushing, and replace with a new one if the wear limit is exceeded.

**Wear limit**

- RHF5 ..... 4.07mm
- RHB51 ..... 4.07mm
- RHB31 ..... 3.65mm

(b) Oil thrower 2

Measure the seal ring groove widths (G1) and (G2), and replace with a new one if the wear limit is exceeded.

**Wear limits**

- RHF5--- G1: 1.31mm, G2: 1.11mm
- RHB51--- G1: 1.31mm, G2: 1.11mm
- RHB31--- G1: 1.04mm, G2: 0.84mm

(c) Thrust bearing 6

Measure the thrust bearing width (J), and replace with a new one if the wear limit is exceeded.

**Wear limit**

- RHF5 ..... 3.98mm
- RHB51 ..... 3.98mm
- RHB31 ..... 3.58mm

(7) Floating bearing 5

- 1) Inspect the floating bearing for abnormal wear, discoloration or surface defect.  
Replace with a new one if defective.
- 2) Measure the inside diameter (C) and outside diameter(D).  
Replace the bearing if either wear limit is exceeded.

**Wear limits**

- RHF5 ..... Outside diameter (D): 12.31mm,  
Inside diameter (C): 8.04mm
- RHB51 ..... Outside diameter (D): 12.31mm,  
Inside diameter (C): 8.04mm
- RHB31 ..... Outside diameter (D): 9.93mm,  
Inside diameter (C): 6.29mm

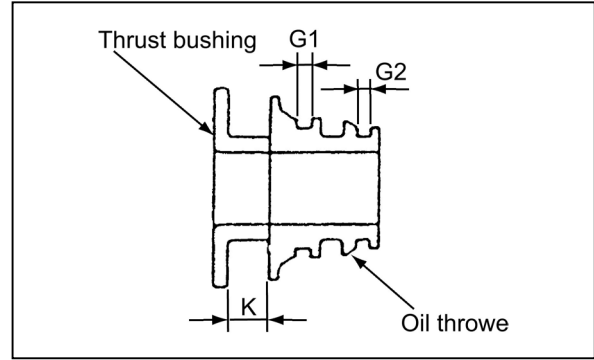

**(8) Bearing housing 15**

- 1) Inspect the housing for cast surface exfoliation due to oxidation and degradation, dent or crack.
- 2) Inspect circlip 16 for chipping or crack, and replace with a new one if defective.
- 3) Measure the (B) and (F) portions of the bearing housing shown in the figure below. Replace with a new one if either wear limit is exceeded.

**Wear limit of bearing housing inside diameter (B)**

RHF5	.....	12.42mm
RHB51	.....	12.42mm
RHB31	.....	10.01mm

**Wear limit of turbine side seal ring inserting portion (F)**

RHF5	.....	15.05mm
RHB51	.....	15.05mm
RHB31	.....	11.03mm

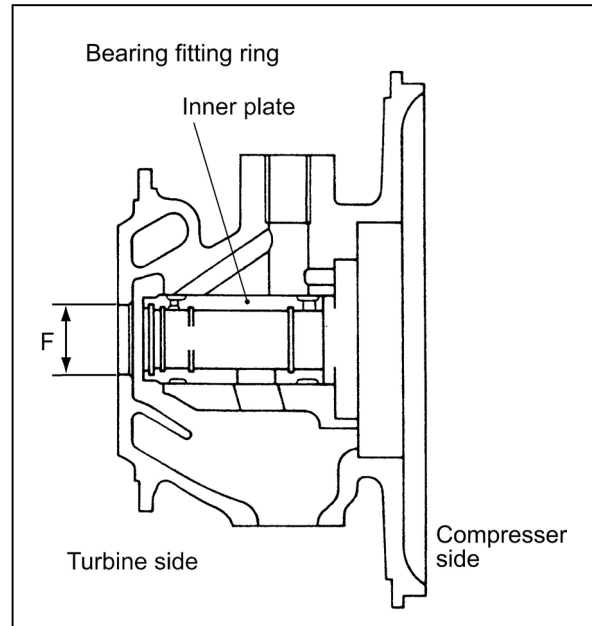
**(9) Seal plate 4**

- 1) Inspect the seal plate for any contact trace, joint surface defect, dent or crack. Replace it if defective.
- 2) Measure the seal ring inserting dimensions (H1 and H2) on the compressor side, and replace the seal ring with a new one if either wear limit is exceeded.

**Wear limits**

RHF5	.....	H1: 12.45mm,	H2: 10.05mm
RHB51	.....	H1: 12.45mm,	H2: 10.05mm
RHB31	.....	H1: 10.04mm,	H2: 8.01mm

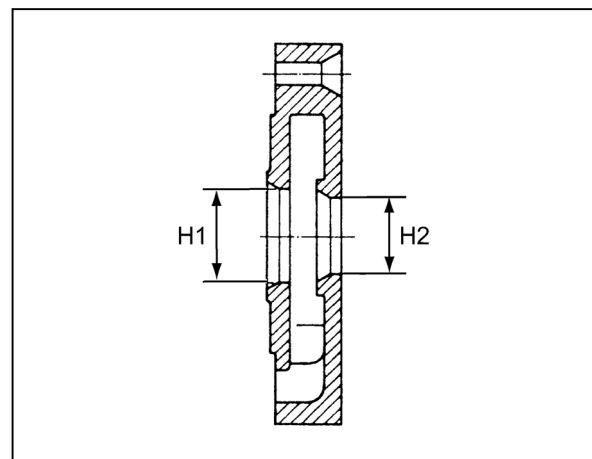
**(10) Seal rings**

Replace seal rings with new ones.

- (11) Inspect keep plates 10, 13 and bolts for any deformation, and replace defective parts with new ones. Also replace M3 Torx machine screws with new ones.



## 8.6 Reassembly Procedure

### 8.6.1 Preparation for reassembly

- 1) Prepare general tools, special tools, liquid gasket (Three Bond No.1207) and Loctite No.242 before reassembling the turbocharger.
- 2) Always replace the following parts with new ones:
  - Turbine side seal ring 1pc.
  - Compressor side seal ring(large) 1pc.
  - Compressor side seal ring(small) 1pc.
  - M3 machine screws 3pcs.
  - M3 machine screws 4pcs.

### 8.6.2 Reassembly

#### (1) Floating bearing installation

- 1) Use the snap ring pliers and install inner circlip 16 on bearing housing 15.
- 2) Install floating bearing 5 in bearing housing 15.
- 3) Use the snap ring pliers and install outer circlip 16 on bearing housing 15.

Note:

- 1) The circlip joint shall be positioned as shown in the figure at right above.  
**The rounded side of the circlip shall face the bearing.**
- 2) Apply lubricating oil on the floating bearing before reassembly.

#### (2) Turbine shaft installation

- 1) Fit the seal ring onto turbine shaft 1.
- 2) Install heat insulating plate 20 on the turbine side of bearing housing 15.
- 3) Apply lubricating oil on the journal portion of the turbine shaft and insert the shaft from the turbine side of bearing housing 15.

Note: Carefully operate so as not to damage the floating bearing by the turbine shaft.  
 The seal ring joint shall be positioned on the lubricating oil inlet side after centering with the turbine shaft.

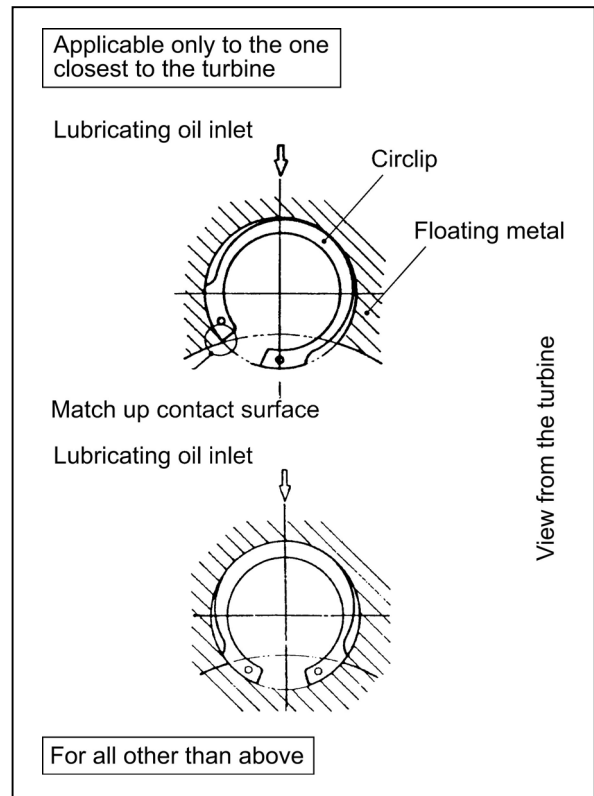

### (3) Thrust bearing installation

- 1) Fit thrust bushing on turbine shaft 1.
- 2) Apply lubricating oil on the bearing portion of thrust bearing 6 and install it in bearing housing 15.
- 3) Apply Loctite on the threaded portion of M3 Torx T machine screw 17 for thrust bearing installation, and use Torx torque driver for installation by tightening to the specified torque.

Tightening torque:  $1.3 \pm 0.1 \text{ N}\cdot\text{m}$  ( $13 \pm 1 \text{ kgf}\cdot\text{cm}$ )

### (4) Seal plate installation

- 1) Fit the seal ring on oil thrower 2.
  - 2) Insert oil thrower 2 into seal plate 4.
- Note: The seal ring joint portion shall be positioned as illustrated at right.
- 3) Apply liquid gasket (Three Bond No.1207) on the seal plate mounting surface on the compressor side of bearing housing 15.

Note: See the illustration below for the applying position.

Applying thickness:  $0.1 \sim 0.2 \text{ mm}$

- 4) Install seal plate 4 on bearing housing 15.
- 5) Apply Loctite on the threaded portion of M3 machine screw for seal plate mounting, and tighten it with a torque screwdriver.

Tightening torque:  $1.3 \pm 0.1 \text{ N}\cdot\text{m}$  ( $13 \pm 1 \text{ kgf}\cdot\text{cm}$ )

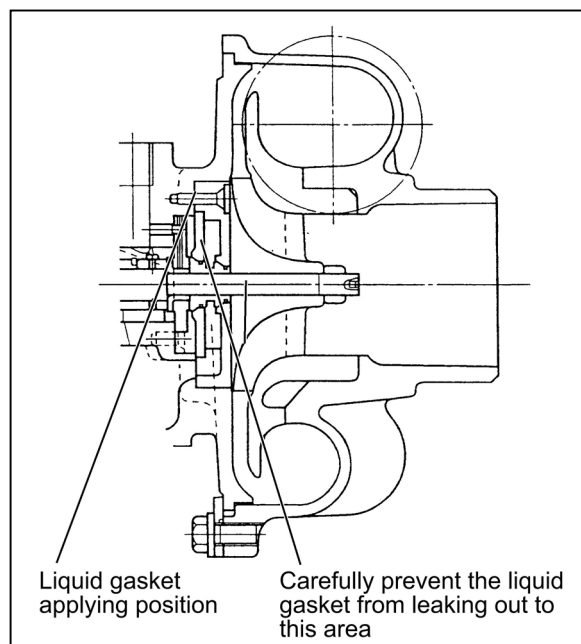
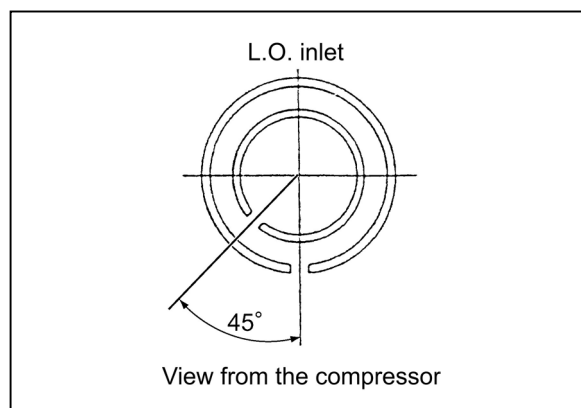

(5) Compressor impeller installation

- 1) Fit compressor impeller 18 onto turbine shaft 1.
- 2) Set a box spanner (10 mm) on the turbine side end of turbine shaft 1, and tighten shaft end nut 19.

Note: Since the shaft end nut has left-handed screw, pay attention to the tightening direction.

Tightening torque:  $2.0 \pm 0.2$ N-m ( $20 \pm 2$ kgf-cm)

(6) Turbine housing installation

- 1) Install bearing housing 15 on turbine housing 11 by aligning the match marks put before disassembly.

Note: In case of part replacement, check the oil inlet and outlet positions and the exhaust gas inlet position before reassembly.

- 2) Install the turbine side keep plate and tighten M8 hexagon bolt 12.

Tightening torque:  $285 \pm 10$ N-m ( $28 \pm 1$ kgf-cm)

(7) Compressor housing installation

- 1) Apply liquid gasket (Three Bond No.1207) on the compressor side flange of bearing housing 15.

Note: See section (4)3) for the portion to be applied.

Applying thickness: 0.1~0.2 mm

- 2) Check the mark and install the compressor housing 7 on the bearing housing 15.

Note: When a part is replaced, confirm a position of an oil entrance and a position of an air exit, and assemble it.

- 3) Install the keep plate 10 on compressor side, and tighten M8 hexagon bolt 8.

Tightening torque:  $48 \pm$ N-m ( $4.7 \pm 0.5$ kgf-cm)

(8) Rotor play measurement

See the inspection procedure in section 8.3.2 for the measurement method.

If the rotor play does not satisfy the standard, reassembly is necessary since assembly error or use of a wrong part is conceivable.

**Service standard of rotor play in axial direction**

RHF5	.....	0.03~0.06mm
RHB51	.....	0.03~0.06mm
RHB31	.....	0.022~0.053mm

**Service standard of rotor play in radial direction**

RHF5	.....	0.08~0.13mm
RHB51	.....	0.08~0.13mm
RHB31	.....	0.061~0.093mm

## 8.7 Handling after Disassembly and Reassembly

When installing the turbocharger on the engine or handling the turbocharger after installation, strictly observe the instructions given below.

Especially pay careful attention for preventing foreign matter entrance into the turbocharger.

### 8.7.1 Instructions for turbocharger installation

#### Lubrication system

- 1) Pour new lubricating oil through the oil filler port before installation on the engine, and manually turn the turbine shaft to lubricate the floating and thrust bearings.
- 2) Flush the oil inlet pipe from the engine and outlet pipe, and check no crushed pipe nor dirt or foreign matter remaining in the pipes.
- 3) Connect the pipes securely so as to ensure no oil leak from joints.

#### Intake system

- 1) Check no foreign matter or dirt in the intake line.
- 2) Connect securely to prevent any air leak from joints with the intake duct and air cleaner.

#### Exhaust system

- 1) Check no dirt or foreign matter in the exhaust system.
- 2) Since heat resistant steel is used for the bolts and nuts, do not use general bolts and nuts for installation. Always apply anti-seizure agent on fastening bolts and nuts to be tightened. (Use heat-resistant hexagon bolts for the turbine housing.)
- 3) Connect exhaust pipes securely to prevent gas leak from each pipe joint.

## 8.8 Troubleshooting

Sufficient turbocharger performance and required engine output cannot be obtained if there is any fault. In such a case, first check each engine part to see there is no engine fault. Then inspect the turbocharger for troubleshooting according to the procedure shown below.

### 8.8.1 Excessively exhaust smoke

#### (1) Insufficient intake air volume

Cause	Corrective action
1) Clogged air cleaner element 2) Blocked air intake port 3) Leak from a joint in intake line	<ul style="list-style-type: none"> <li>● Replace or wash the element.</li> <li>● Correct to the normal state.</li> <li>● Inspect and repair.</li> </ul>

#### (2) Turbocharger revolution failure

Cause	Corrective action
1) Deposit of impurities in oil sticking on the turbine side seal portion to make turbine revolution heavy  2) Sticking bearing <ul style="list-style-type: none"> <li>● Insufficient lubrication or clogged lubrication piping</li> <li>● Excessively high oil temperature</li> <li>● Unbalanced rotating part</li> <li>● Insufficient warming up or sudden stoop from loaded operation (no-load operation)</li> </ul> 3) Contact or breakdown of turbine wheel or blower vane <ul style="list-style-type: none"> <li>● Excessive revolution</li> <li>● Excessive exhaust temperature rise</li> <li>● Foreign matter invasion</li> <li>● worn bearing</li> <li>● Assembly defect</li> </ul>	<ul style="list-style-type: none"> <li>● Turbocharger overhaul (disassembly and washing) with lubricating oil replacement</li> <li>● Turbocharger overhaul (disassembly and repair)</li> <li>● Lubricating oil line inspection, repair of defective portion and lubricating oil replacement</li> <li>● Rotating part replacement or washing</li> <li>● Strict observance of instructions in operation manual</li> <li>● Inspection and repair of each engine part</li> <li>● Perfect foreign matter elimination in disassembled state, followed by inspection and repair of individual air cleaner and engine components</li> <li>● turbocharger overhaul (disassembly and repair)</li> <li>● Reassembly</li> </ul>

#### (3) Influence of exhaust resistance

Cause	Corrective action
1) Exhaust gas leak before the turbocharger to decrease its revolutions  2) Deformed or clogged exhaust pipe to decrease turbocharger revolutions	<ul style="list-style-type: none"> <li>● Joint inspection and correction</li> <li>● Correct to the normal state.</li> </ul>

### 8.8.2 White smoke generation

Cause	Corrective action
1) Clogged or deformed oil return pipe causing oil flow to the blower or turbine side  2) Excessive bearing wear causing abnormal wear or damage of seal ring	<ul style="list-style-type: none"> <li>● Repair or pipe replacement</li> <li>● Turbocharger disassembly and repair</li> </ul>

**8.8.3 Sudden oil decrease**

Cause	Corrective action
1) Excessive bearing wear causing abnormal wear or damage of seal ring	● Turbocharger disassembly and repair

**8.8.4 Decrease in output**

Cause	Corrective action
1) Gas leak from any part in exhaust piping	● Inspection and repair of defective portion
2) Air leak from discharge side of blower	
3) Clogged air cleaner element	● Element cleaning or replacement
4) Fouled or damaged turbocharger	● Turbocharger disassembly and repair or replacement

**8.8.5 Poor (slow) response (starting) of turbocharger**

Cause	Corrective action
1) Hard carbon deposit on the turbine side (wheel sealing portion) to make turbine shaft revolution heavy	● Turbocharger disassembly and washing with lubricating oil replacement
2) Incomplete combustion	● Engine combustion state inspection, followed by improvement of combustion to normal state

**8.8.6 Abnormal sound or vibration****(1) Abnormal sound generation**

Cause	Corrective action
1) Excessively narrowed gas path due to clogged nozzle in turbine wheel chamber or reverse flow of blower discharge in acceleration (generally called surging)	● Turbocharger disassembly and washing
2) Contact rotating part	● Turbocharger disassembly and repair or replacement

**(2) Vibration**

Cause	Corrective action
1) Loosened intake, exhaust or oil pipe connection with the turbocharger	● Turbocharger installation status check and repair of defective portion
2) Damaged bearing, contact between rotating part and adjacent part, or chipping of turbine wheel or blower vane due to foreign matter in vasion	● Turbocharger disassembly with repair or replacement, or perfect removal of foreign matters in case of foreign matter invasion
3) Unbalanced rotating part	● Repair or replacement of rotating part

## 9. STARTING MOTOR

As a representative example of starter, the one for 4TNV94L-98 and 4TNV106 (T) is shown in this chapter.

### 9.1 For 4TNV94L/ 98

#### 9.1.1 Specifications

Manufacturer's model (Hitachi)		-	S13-204	S13-205
Yanmar code		-	129900-77010	129900-77020
Nominal output		kW	2.3	←
Weight		kg	5.5	←
Revolution direction (as viewed from pinion)		-	Clockwise	←
Engagement system		-	Magnetic shift	←
No-load	Terminal voltage/current	V/A	11/140 or less	←
	Revolution	rpm	4100 or above	←
Loaded	Terminal voltage/current	V/A	2.5/1050 or less	←
	Torque	Nm(kgf·m)	24.5(2.5) or above	←
Clutch system		-	Overrunning	←
Pinion projection voltage (at 100°C)		V	8.6 or less	←
Pinion DP or module/number of teeth		-	M3/9	←
difference (O-ring, oil seal)		-	Dry (none)	Wet (with)
Application		-	Standard	Option

### 9.1.2 Components

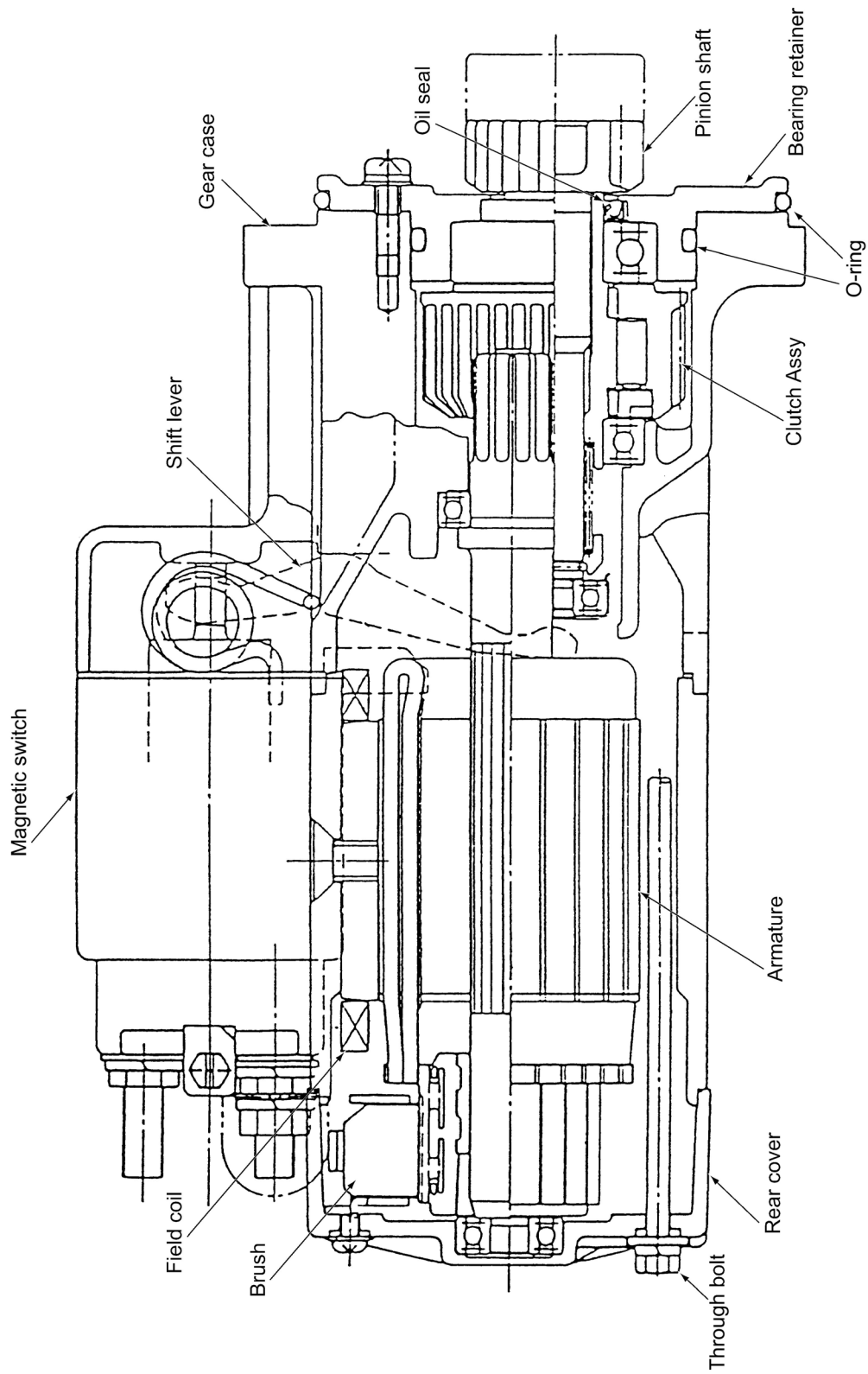



### 9.1.3 Troubleshooting

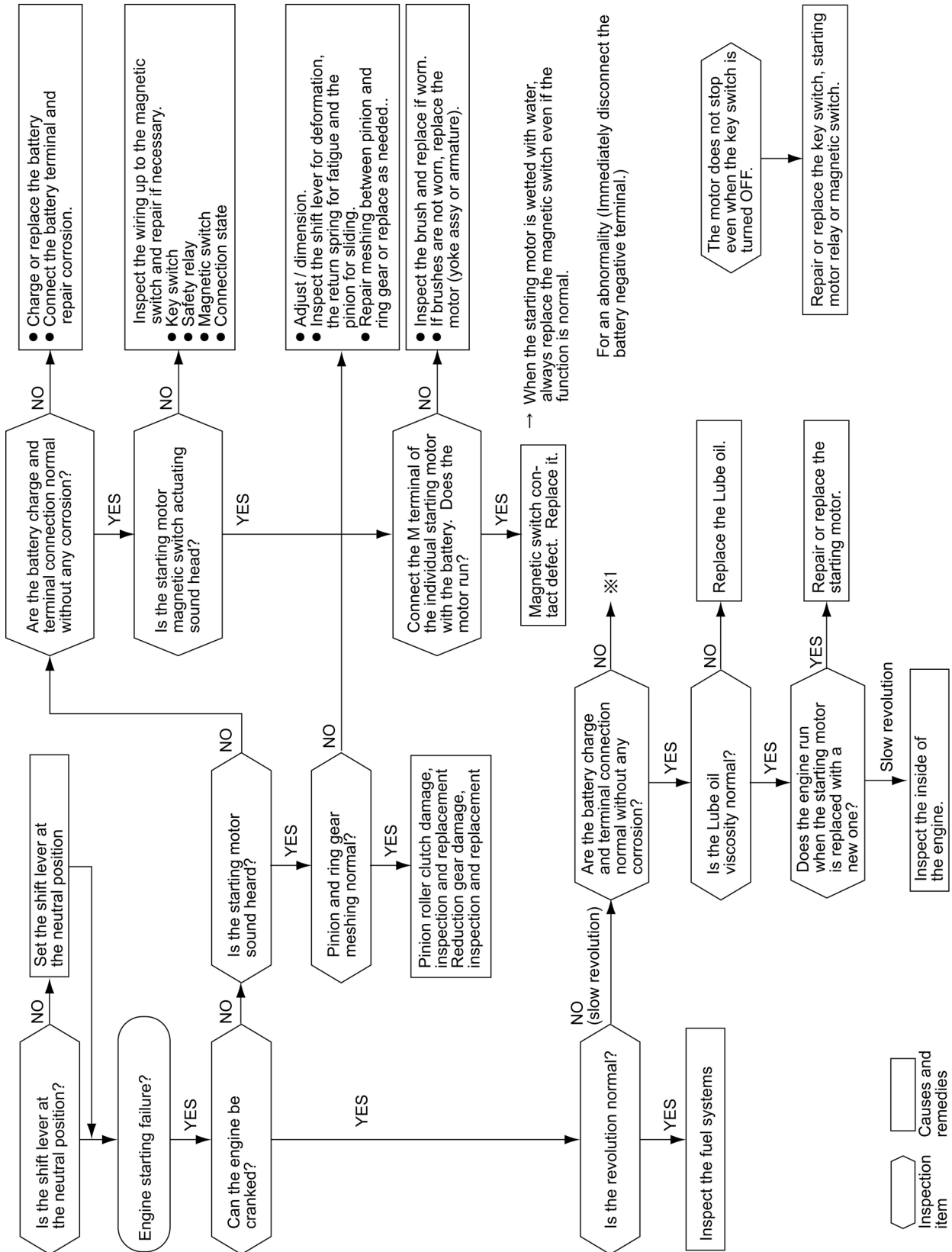

### 9.1.4 Names of parts and disassembly procedure

#### (1) Disassembling order

- 1) Nut M8 (Disconnect the connecting wire.) ..... See the disassembly drawing.
- 2) Screw M4 (2)
- 3) Through bolt M5 (2)
- 4) Rear cover
- 5) Brush holder
- 6) Yoke assy.
- 7) Armature
- 8) Bolt M6 (2)
- 9) Magnetic switch
- 10) Dust cover
- 11) Shift lever
- 12) Screw M4 (3)
- 13) Bearing retainer
- 14) Gear case
- 15) Pinion stopper clip
- 16) Pinion stopper
- 17) Return spring
- 18) Pinion shaft
- 19) Clutch assy.

Disassembly drawing

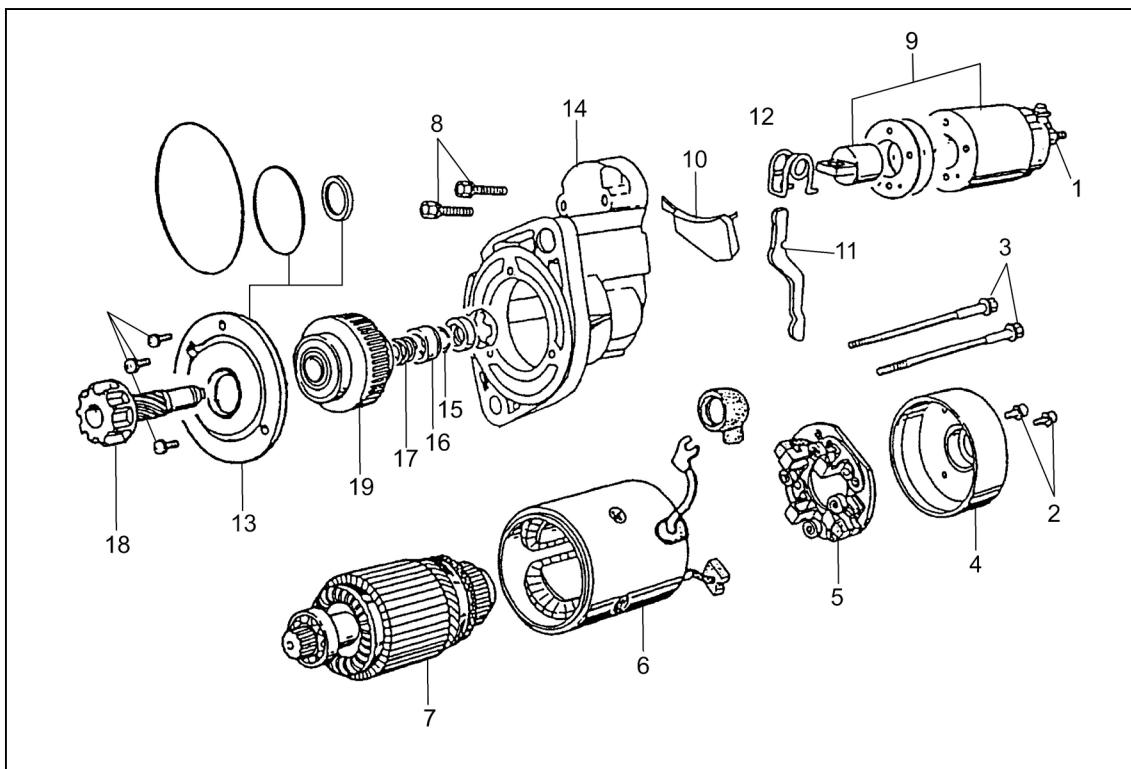

## (2) Disassembly procedure

## 1) Nut M8

Remove the magnetic switch nut M8 (12 mm), and disconnect the connecting wire.

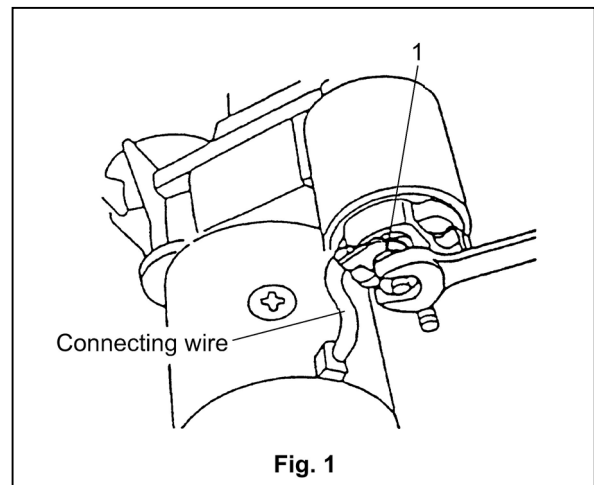

## 2) Screw M4 (2)

## 3) Through bolt M5 (2)

## 4) Rear cover

Remove the M4 screw fastening the brush holder and remove through bolt M5 for rear cover removal.

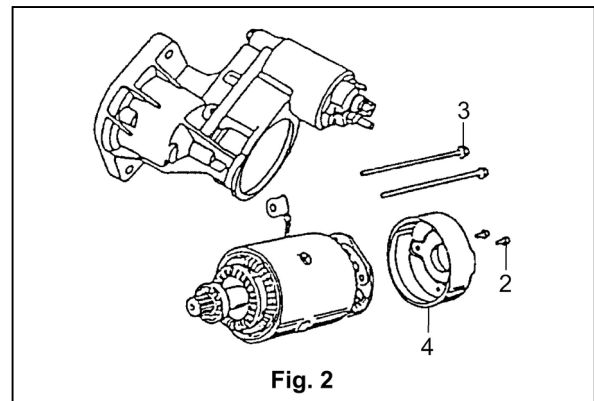

## 5) Brush holder

Pull the brush spring up with the brush spring puller. On the negative (-) side, bring the brush spring into contact with the side of the brush for lifting from the commutator surface. On the positive (+) side, extract the brush from the brush holder.

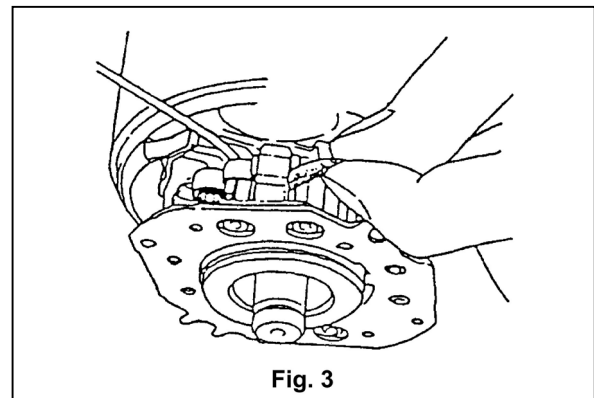

6) Yoke Assy.

7) Armature

Remove the brush holder. The armature and yoke assy can now be removed.

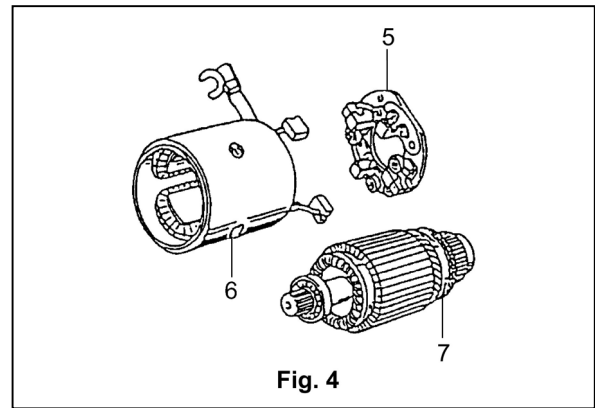

8) Bolt M6 (2)

9) Magnetic switch

Remove bolt M6 (10 mm), and the magnetic switch can be removed.

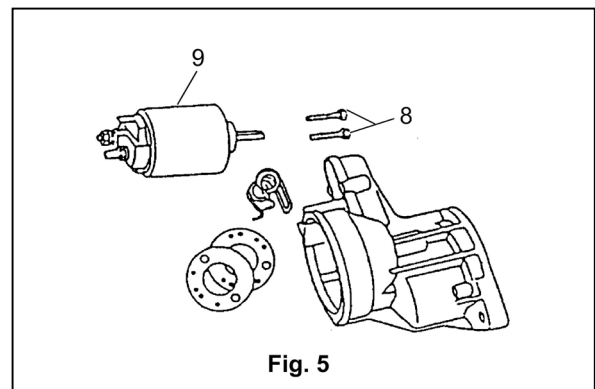

10) Dust cover

11) Shift lever

Take the dust cover out from the gear case. The shift lever can be removed.

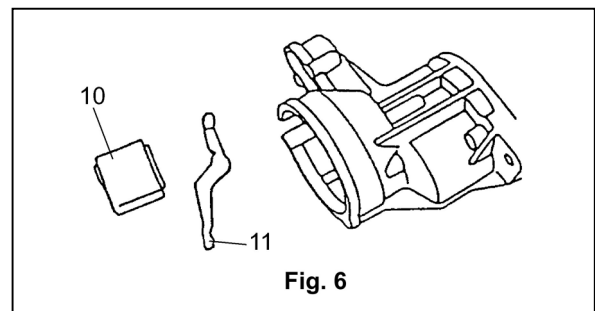

12) Screw M4 (3)

13) Bearing retainer

14) Gear case

Remove screw M4, and the bearing retainer and clutch assy can be removed.

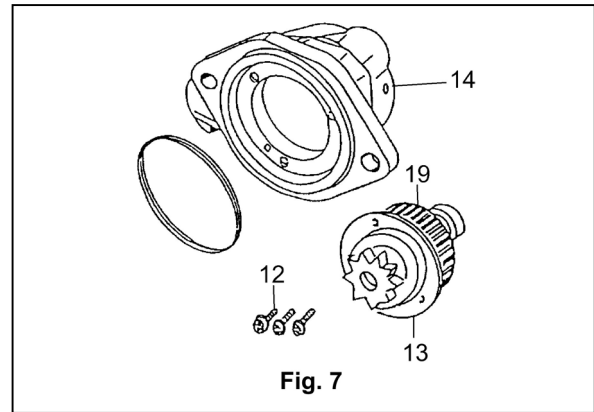

15) Pinion stopper clip

Remove the bearing retainer at the edge and the bearing, and shift the pinion stopper toward the pinion. Use a plain screwdriver and pry to remove the pinion stopper clip.

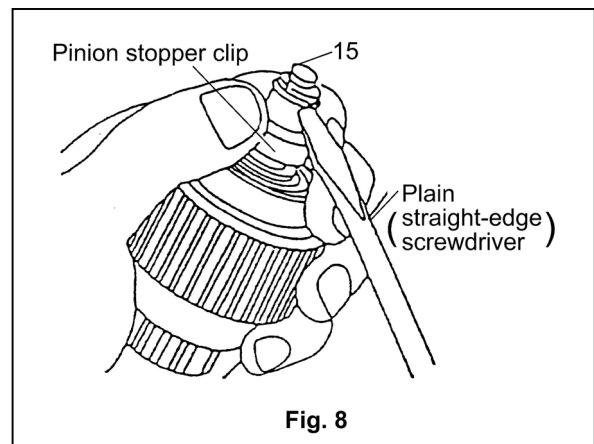

16) Pinion stopper

17) Return spring

18) Pinion shaft

19) Clutch Assy

Remove the pinion stopper clip. The pinion stopper, return spring, pinion shaft and bearing retainer can be removed.

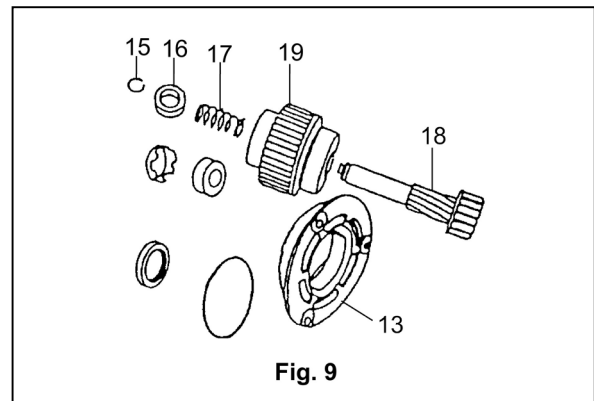

Disassembly is completed now.

### 9.1.5 Inspection and Maintenance

#### (1) Armature

##### (a) Commutator outside diameter

Measure the commutator outside diameter and replace the commutator if the measured value is less than the limit.

Standard	Limit
36.5	35.5

mm

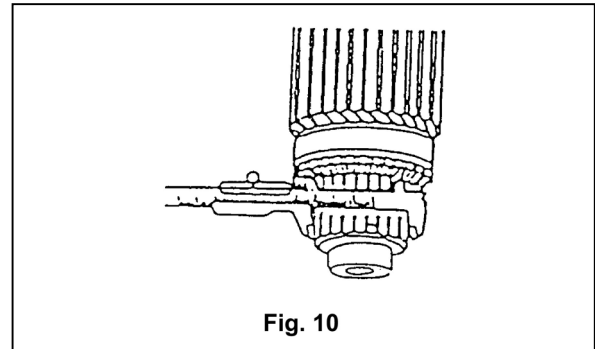

##### (b) Armature coil continuity test

Check continuity between commutator segments with a multimeter. Good if continuity exists.

In case of no continuity (coil disconnection), replace the armature.

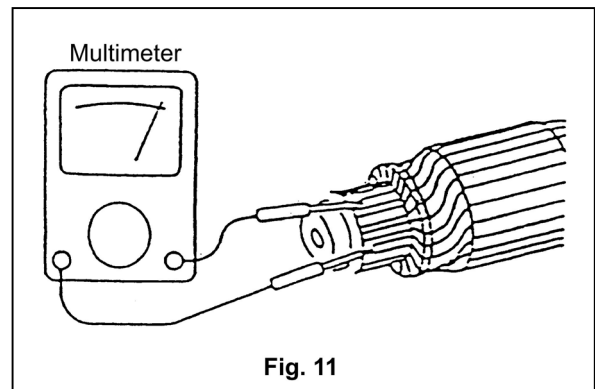

##### (c) Armature coil insulation test

Inspect the continuity between a commutator segment and the shaft or core with a multimeter. Good if no continuity exists.

If continuity exists (coil short circuit), replace the armature.

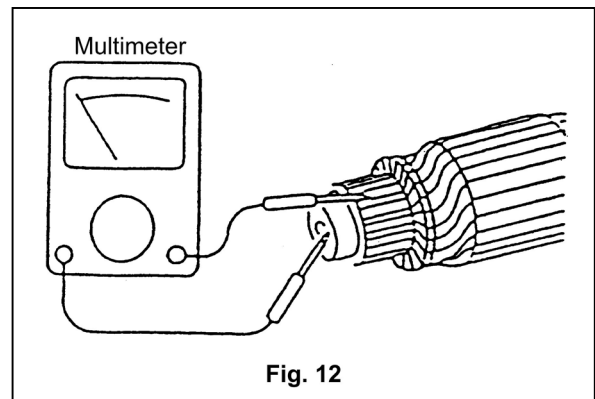

(d) Armature and commutator run-out

Use a dial gage and measure the armature core run-out and commutator run-out. Correct or replace if the limit is exceeded.

	mm	
	Standard	Limit
Armature	0.03	0.2
Commutator	0.03	0.2

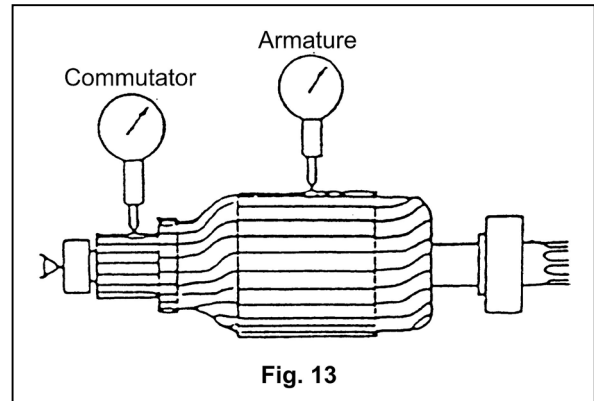

(e) Commutator surface inspection

If the commutator surface is roughened, grind with #500 to #600 emery cloth.

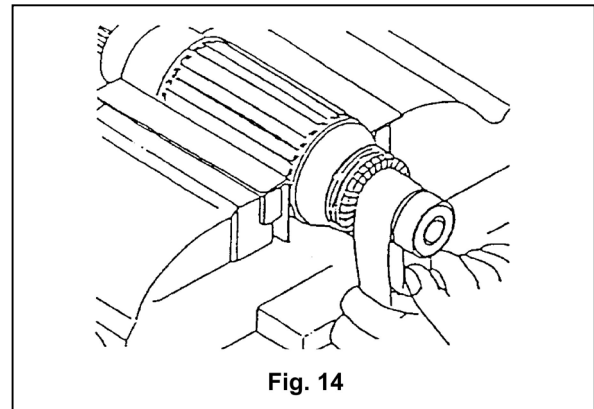

(f) Commutator insulation depth

Measure the depth of the insulating material between commutator segments, and correct it if it is less than the limit.

	mm	
	Standard	Limit
	0.5~0.8	0.2

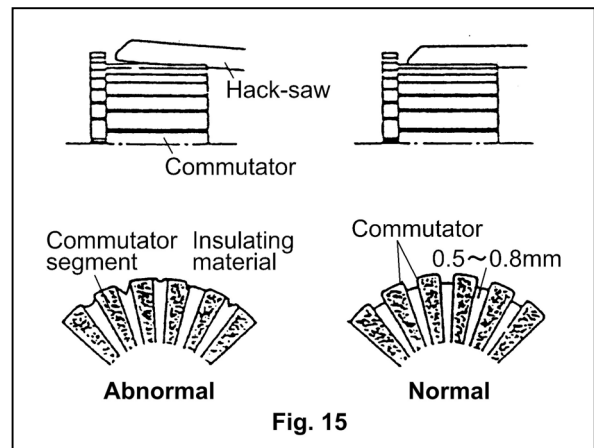

(2) Field coil

(a) Field coil continuity test

Check continuity between field coil terminals. Good if continuity exists.

If no continuity (coil disconnection), replace the field coil.

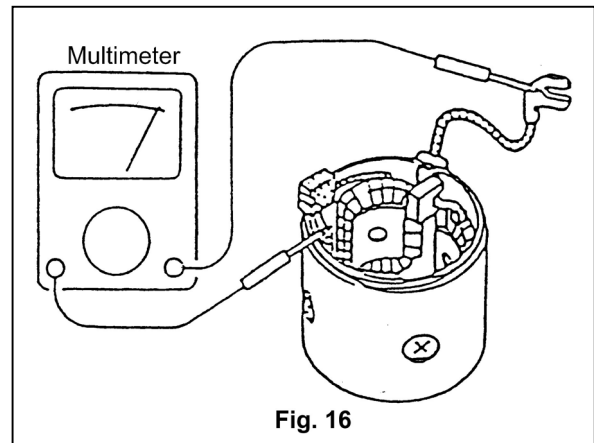

(b) Field coil insulation test

Check continuity between field coil terminal and yoke. Good if no continuity exists.

If continuity exists (coil short circuit), replace the armature.

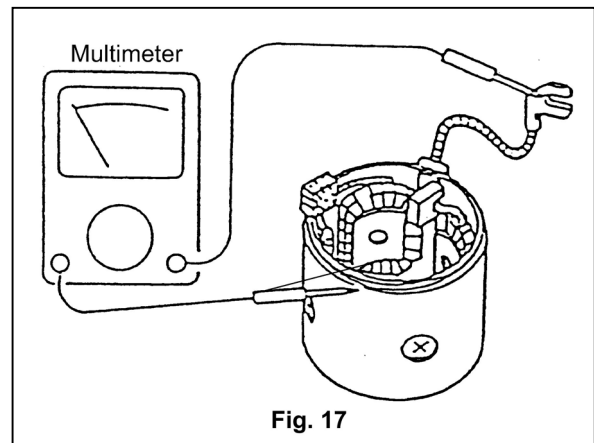

(3) Brush

Measure the length of the brush. Replace with a good one if the length is less than the limit.

mm	
Standard	Limit
15	9

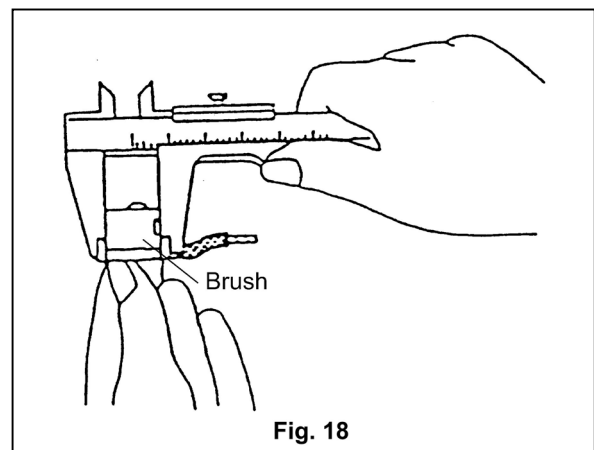



**(4) Brush holder****(a) Brush holder insulation test**

Check the continuity between the brush holder (+ side) and base (- side) with a multimeter. Good if no continuity exists.

If continuity exists (insulation defect), replace the brush holder.

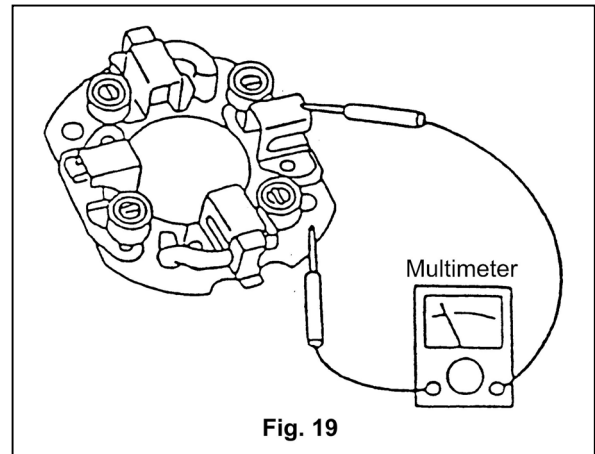

Fig. 19

**(b) Brush spring inspection**

Inspect the brush spring pressure.

	N(kgf)
Standard spring force	
	31~39 (3.1~3.9)

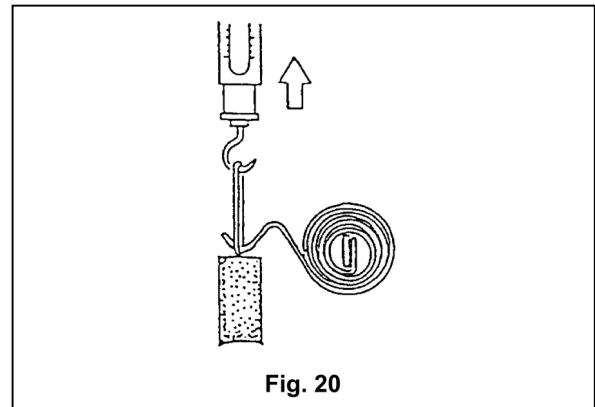

Fig. 20

**(5) Magnetic switch**

When the starting motor is wetted with water, always replace the magnetic switch with a new even if the function is normal.

**(a) Shunt coil continuity test**

Check the continuity between the S terminal and the switch body. Good if continuity exists.

If no continuity (coil disconnection), replace the magnetic switch.

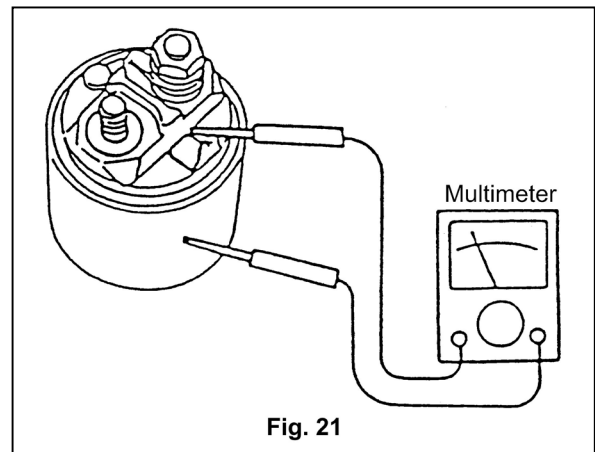
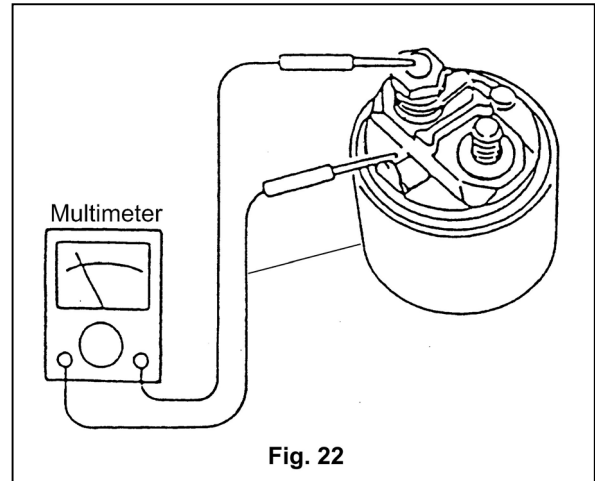

Fig. 21

**(b) Series coil continuity test**

Check continuity between the S and M terminals.  
Good if continuity exists.

If no continuity (coil disconnection), replace the magnetic switch.

**(c) Contact continuity test**

Depress the magnetic switch with the plunger at the bottom. Check continuity between the B and M terminals with a multimeter. Good if continuity exists.

If no continuity (coil continuity defect), replace the magnetic switch.

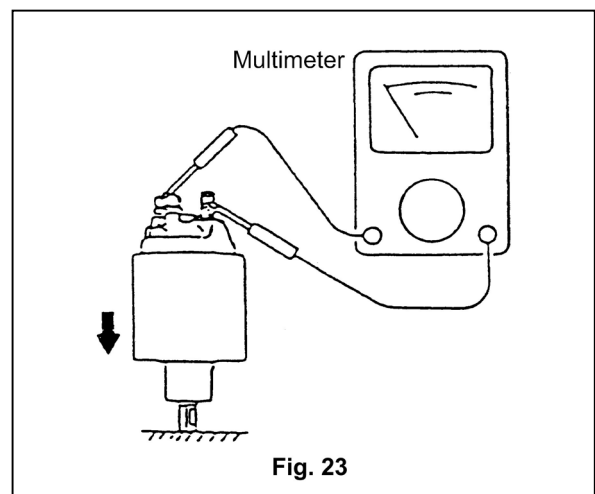
**(6) Pinion clutch****(a) Pinion inspection**

Manually rotate the pinion. Inspect if it is rotated smoothly in the driving direction, and is locked in the opposite direction. Replace the pinion clutch if abnormal.

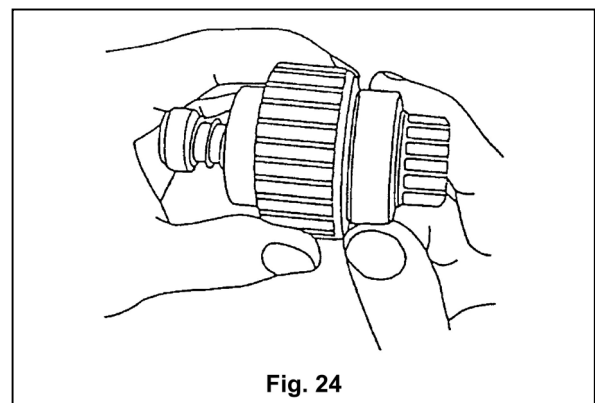

**(b) Pinion sliding inspection**

Check if the pinion slide smoothly in the axial direction. If damaged, rusted or heavy in sliding, repair it. If grease is applied too much on the pinion shaft, sliding becomes heavy.

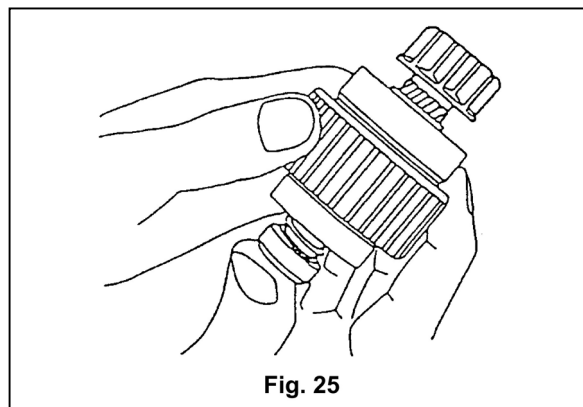

Fig. 25

**(c) Ball bearing inspection**

Rotate the ball bearing while holding the outer race with fingertips. Inspect if it is sticking or if there is play.

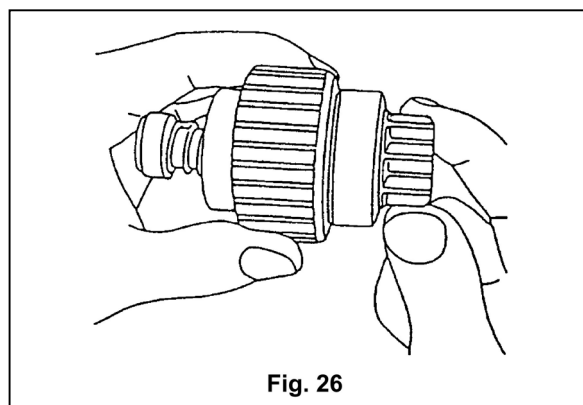

Fig. 26

**9.1.6 Service standards**

Brush	Spring force		N(kgf)	35(3.6)
	Standard height/wear limit		mm	15/9
Magnetic switch resistance, series coil/shunt coil (at 20°C)			Ω	0.27/0.60
Commutator	Standard diameter/limit diameter		mm	36.5/35.5
	Difference between maximum and minimum diameter	Repair limit/repair accuracy	mm	0.2/0.03
	Mica undercut depth chips	Repair limit/repair accuracy	mm	0.2/0.5~0.8
Bearing type	Armature front	Nominal number	-	6903DDU
	Armature rear		-	608DDU
	Pinion front		-	60004DDU
	Pinion rear		-	6904DDU
L dimension (pinion projection length)			mm	0.3-1.5

### 9.1.7 Assembly

The assembly procedure is the reverse of the disassembly procedure, but pay attention to the following points:

#### (1) Grease application points

- Gears in the gear case
- Shift lever operating portion
- Pinion sliding portion
- Magnetic switch plunger sliding portion

Use the specified grease as below table at all points.

Pinion and magnetic switch plunger sliding portions	NPCFG-6A
Gears	MALTEMP SRL
Shift lever operating portion	ALBANIA No.1

#### (2) Magnetic switch assembly

- 1) Install the shift lever on the magnetic switch with the torsion spring in-between.

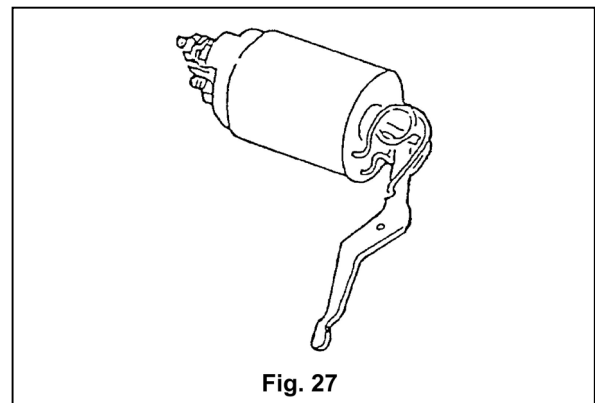

- 2) For installation on the gear case, install the magnetic switch with the shift lever on the gear case after pulling the pinion out. Fix the magnetic switch by tightening a built-in bolt M6. Do not forget to install the dust cover (adjusting shim).

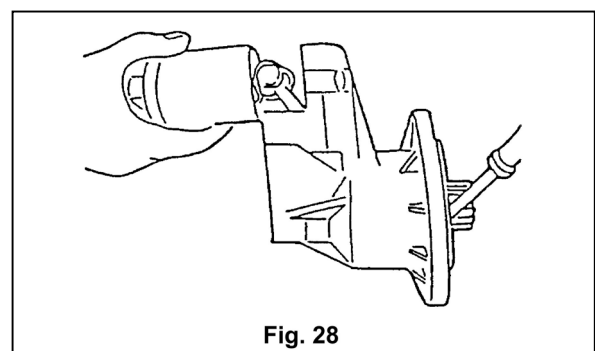

**(3) Pinion projection length**

Connect the positive (+) lead from the battery to terminal S and negative (-) lead to terminal M. Turn the switch ON and measure the pinion moving distance L in the thrust direction. Perform this test within 10 seconds.

	mm
	Standard
L	0.3~1.5

**Note:** Before measuring the dimension, pull the pinion out lightly in the direction of the arrow.

If the measured L dimension is outside the standard range, either insert or remove the dust cover (adjusting shim 0.5 mm, 0.8 mm) for adjustment.

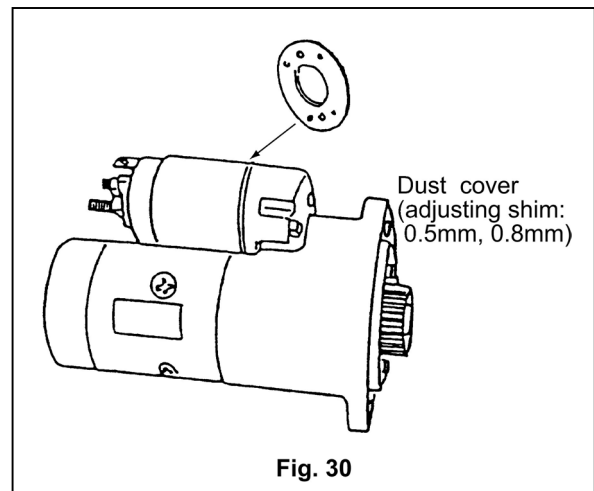
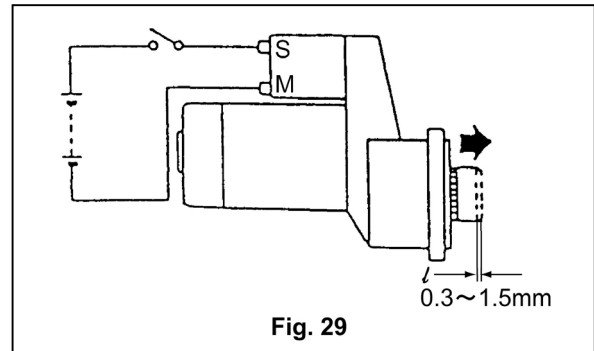

### 9.1.8 Characteristic test

Since the characteristics can be checked roughly by means of a simple no-load test as explained below.

NOTE: Complete the test quickly since the rating of the starting motor is 30 seconds.

#### (1) No-load test

Fix the starting motor on a test bench and connect wiring as shown in Fig.31. When the switch is closed, a current flows in the starting motor, which is rotated at no-load. Measure the current, voltage and number of revolutions then and check if they satisfy the specified characteristics.

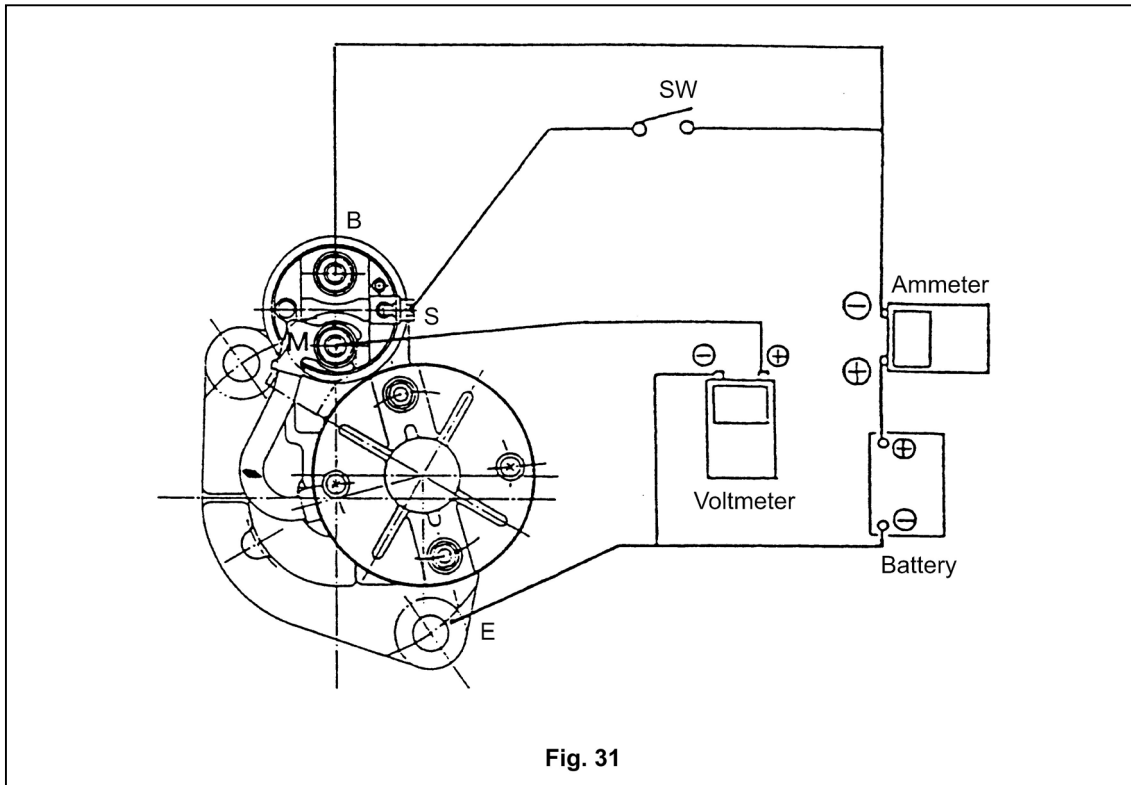

## 9.2 For 4TNV106(T)

### 9.2.1 Specifications

Manufacturer's model (Hitachi)		-	S13-138
Yanmar code		-	129953-77010
Nominal voltage		V	12
Nominal output		kW	3.0
Rating		Sec	30
Revolution direction (as viewed from pinion)		-	Clockwise
Clutch system		-	Roller clutch
Engagement system		-	Magnetic shift
Pinion: Module/number of teeth		-	M3/9
Weight		kg	7.3
Pinion projection voltage (at 100°C)		V	8 or less
No-load	Terminal voltage/current	V/A	12/180 or less
	Revolution	rpm	3000 or more
Loaded	Terminal voltage/current	V/A	9/500
	Torque	N·m(kgfm)	16.7(1.7) or more
	Revolution	min-1	1270 or more

### 9.2.2 Configuration drawing

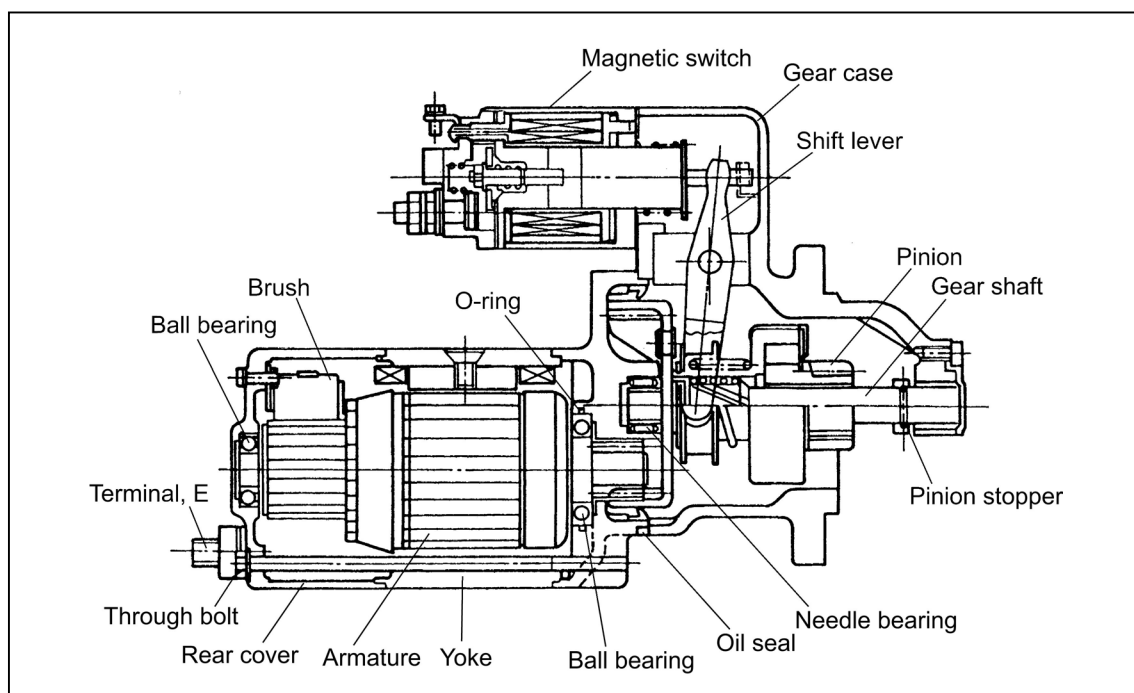

### 9.2.3 Troubleshooting

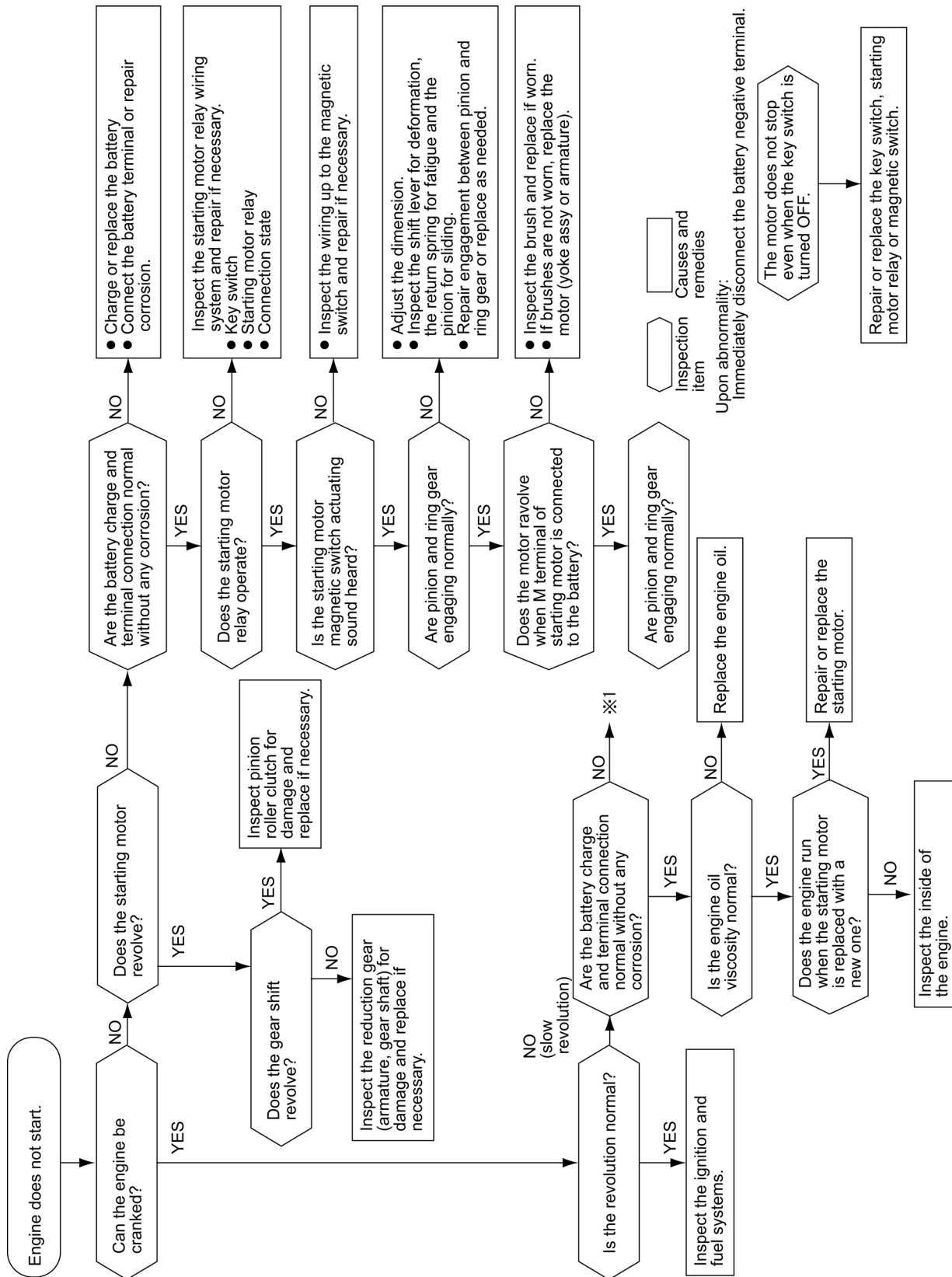



### 9.2.4 Component names and disassembly procedure

#### (1) Disassembly procedure

- 1) Disconnect the lead.
- 2) Remove the magnetic switch.
- 3) Remove the rear cover.
- 4) Remove the brush holder.
- 5) Disassemble the gear case and center bracket.
- 6) Remove the shift lever pin.
- 7) Remove the gear case dust cover.
- 8) Remove the pinion.

#### (2) Disassembly diagram

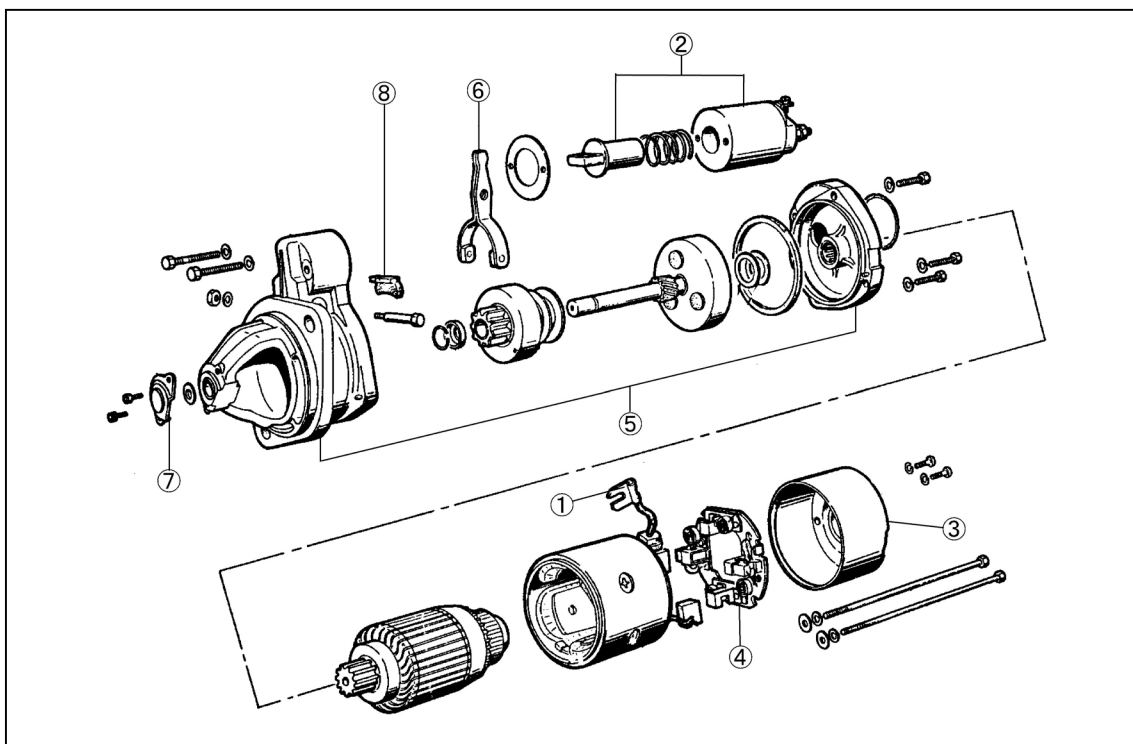

### 9.2.5 Disassembly procedure

#### (1) Disconnecting the lead

Loosen the M8 nut (12mm) of the magnetic switch and disconnect the lead.

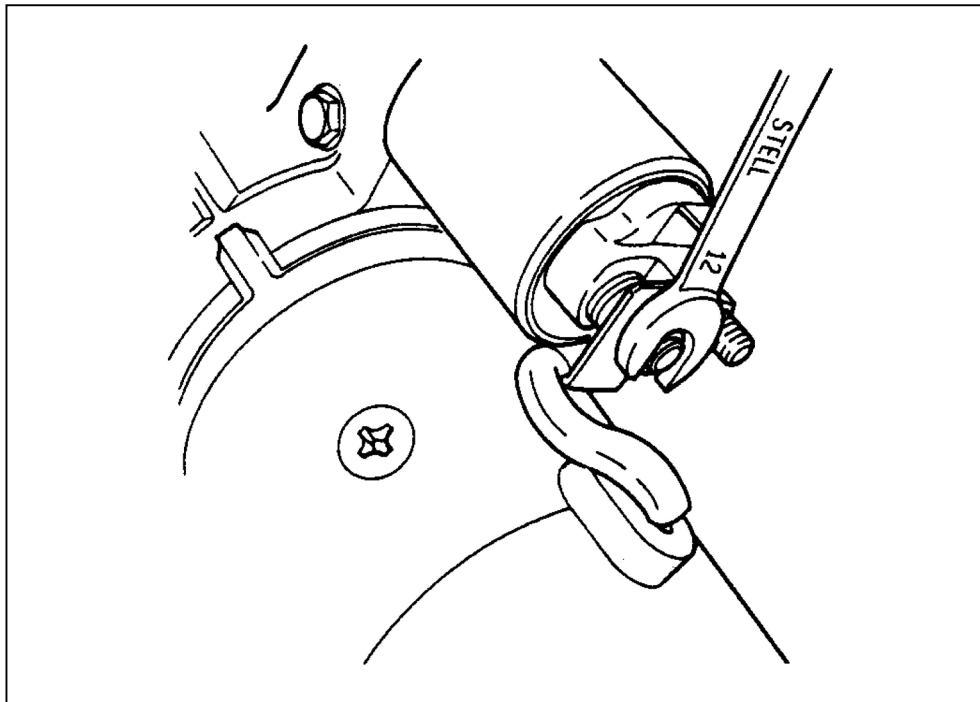

(2) Removal of magnetic switch  
Remove the M6 bolts (10mmx2).

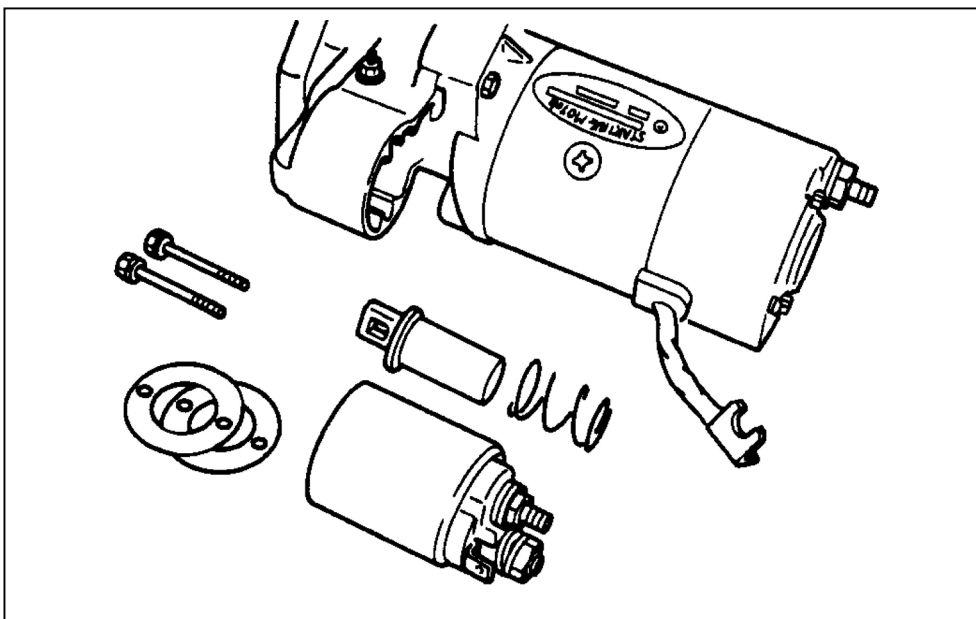
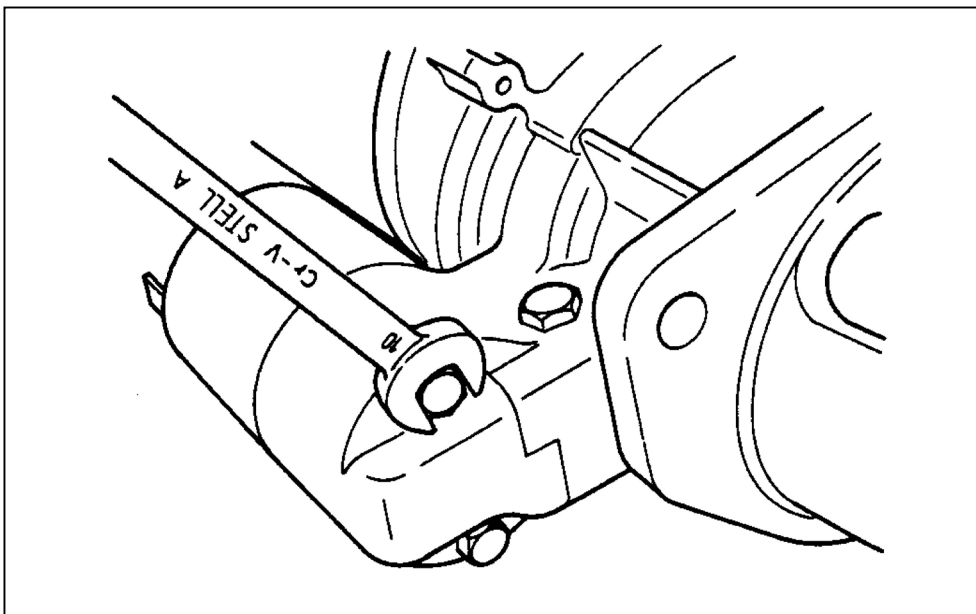

### (3) Removal of rear cover

Remove the brush holder tightening screws (4mm $\phi$ x2) and the M5 through bolts (x2).  
Next, disconnect the rear cover from the yoke using a – screwdriver.

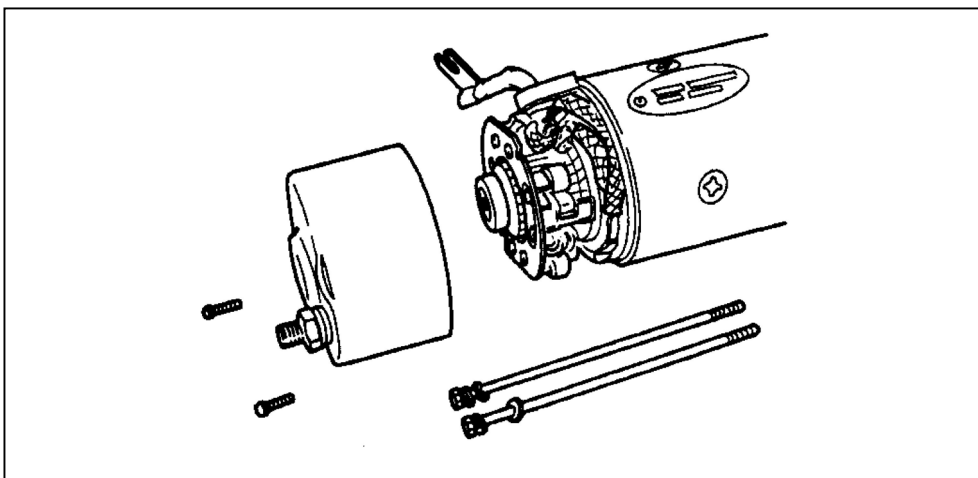
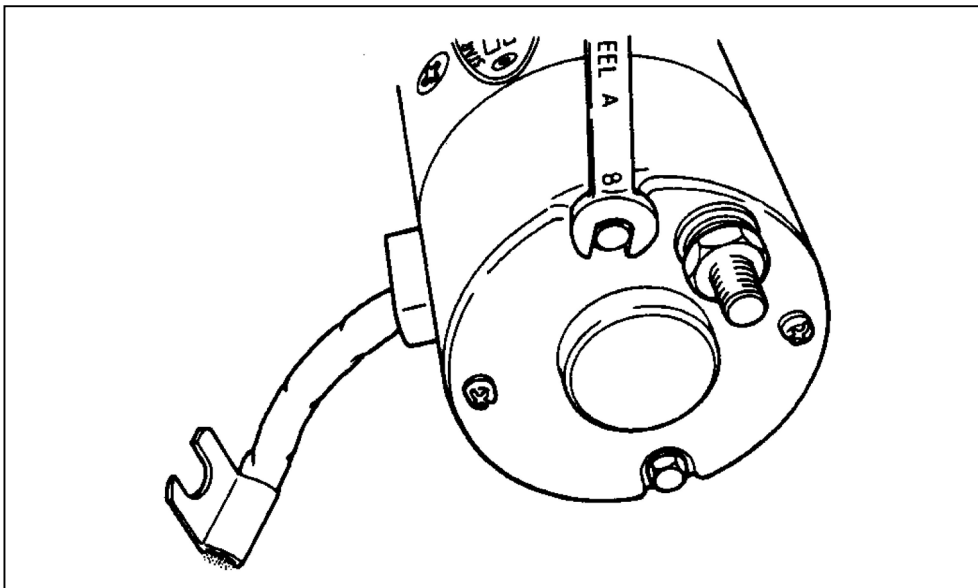

#### (4) Removal of brush holder

For the negative (-) brush, bring the brush spring into contact with the side of the brush for lifting from the commutator surface.

For the positive (+) brush, extract the pull out the brush from the brush holder.

After the brush holder is removed, the armature and yoke can be disassembled.

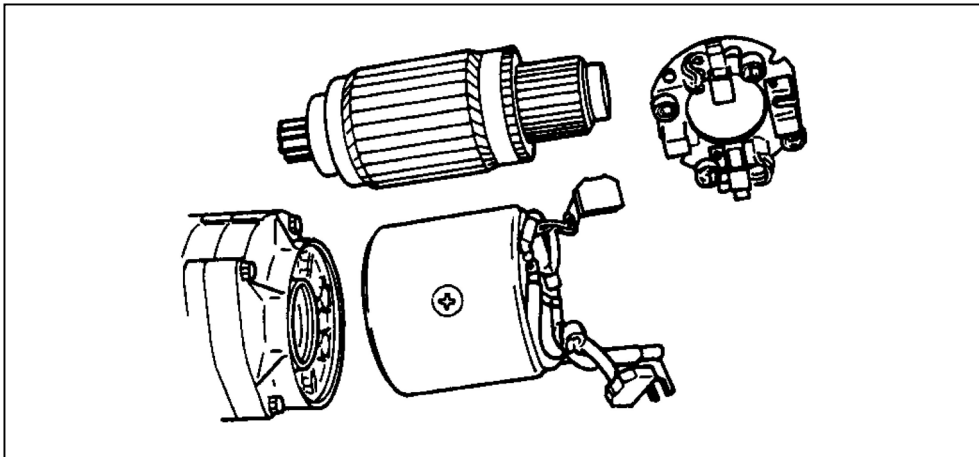
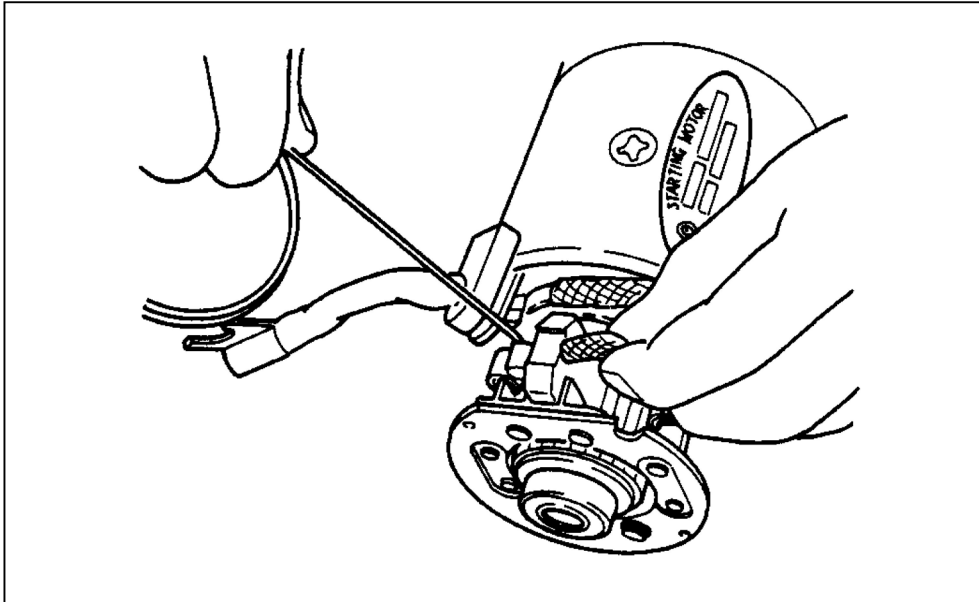

**(5) Separating gear case from center bracket**

Remove three M6 bolts (10mm) fastening the gear case to the center bracket.  
After removal of the M6 bolts, the center bracket and oil seal can be removed.

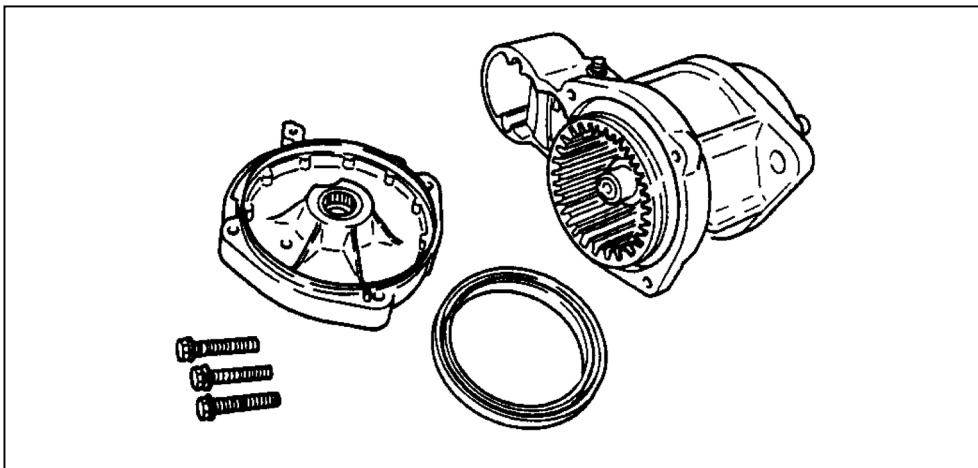
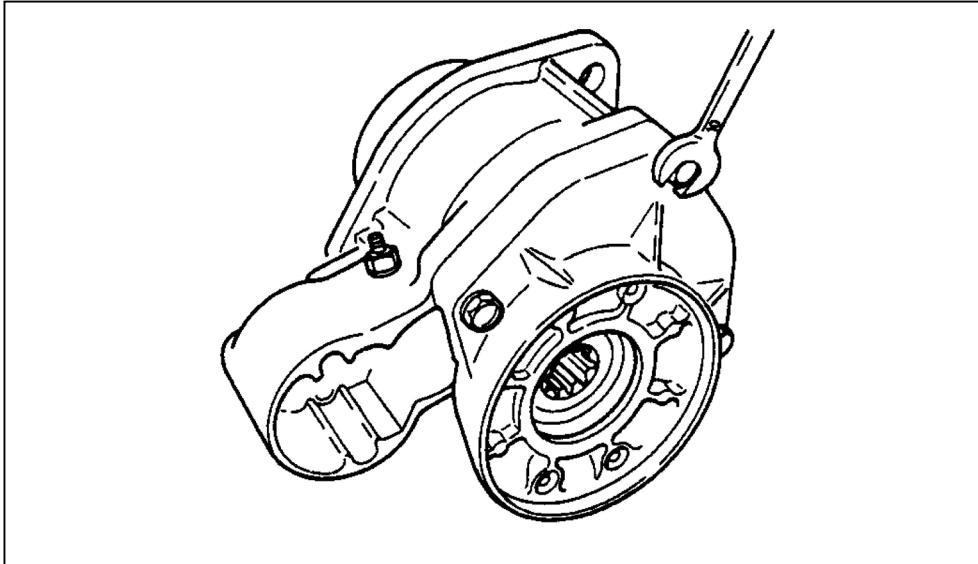

**(6) Removal of shift lever pin**

Remove the M6 nut (10mm) and pull out the shift lever pin.

Now, the dustcover, shift lever, gear case and gear shaft can be removed.

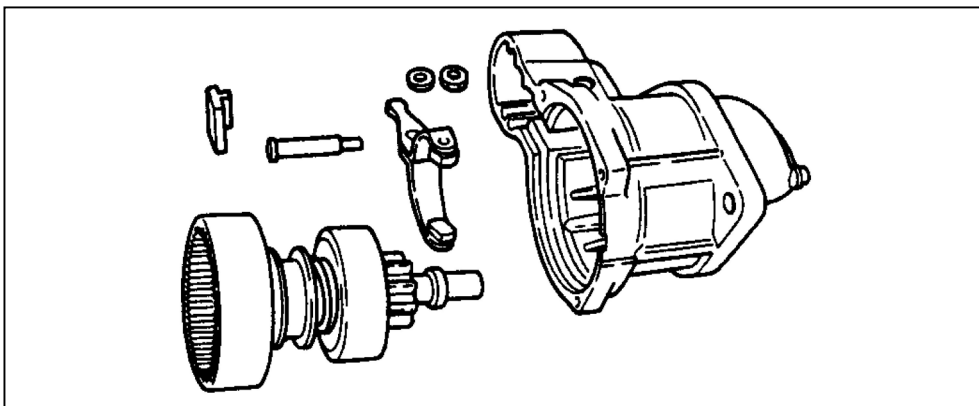
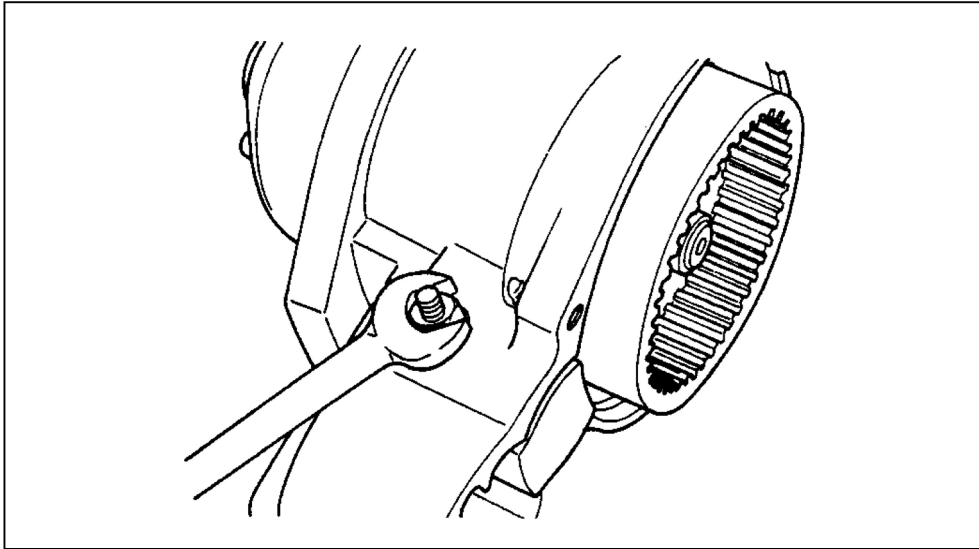

(7) Removal of gear case dust cover

Remove the two M5 bolts (using 4 mm hexagon wrench) to disassemble the dust cover from the gear case.

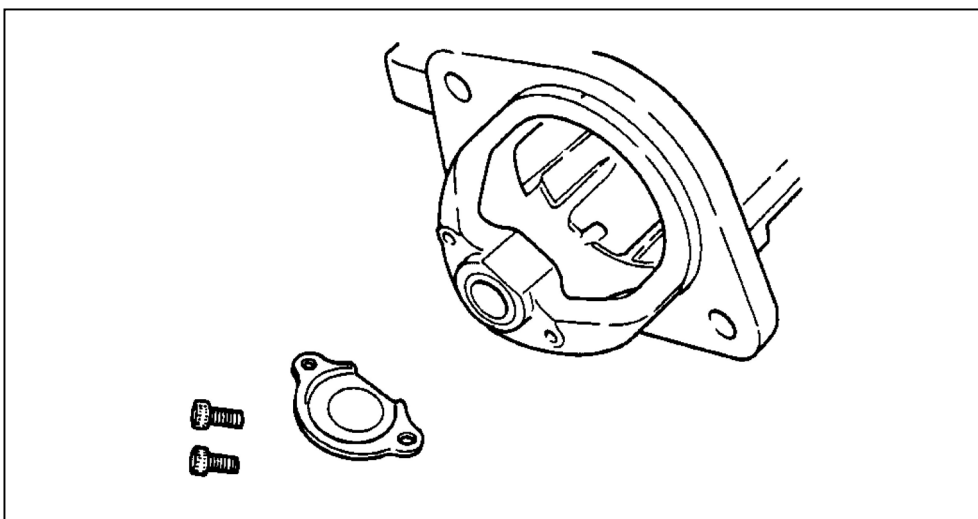
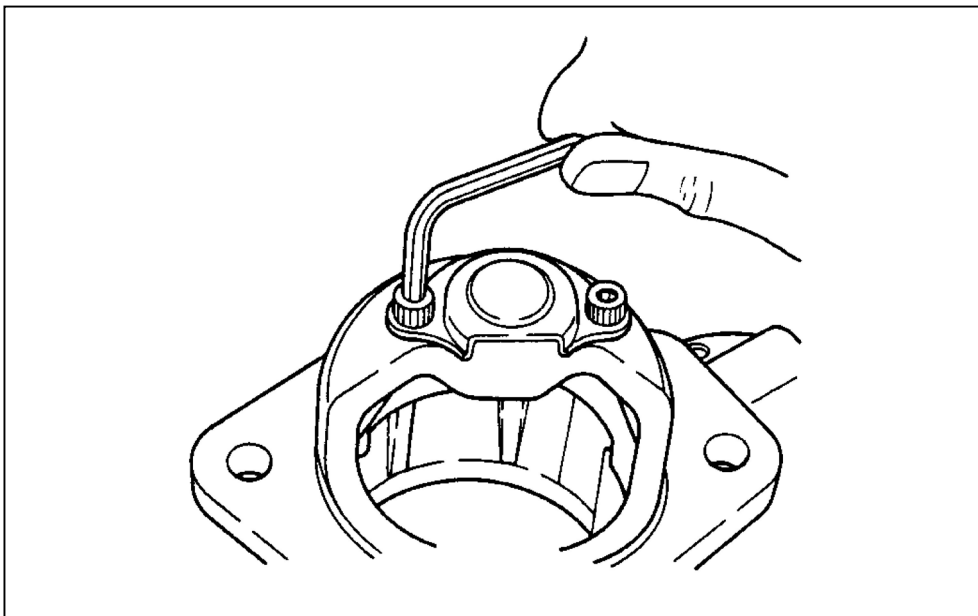



(8) Removal of pinion

Slide the pinion stopper towards the pinion and remove the pinion stopper clip using a – screwdriver.

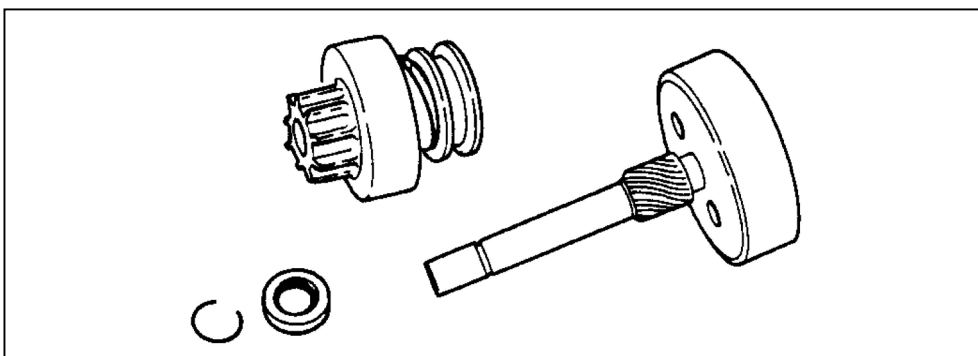
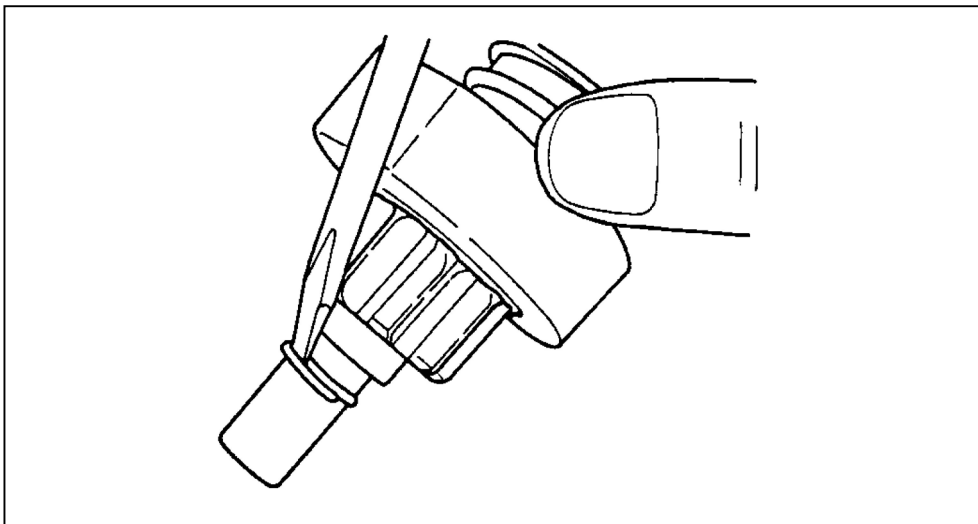

## 9.2.6 Inspection and maintenance

### (1) Armature

- 1) Check the commutator for rough surface. If so, smooth the surface using #500 to #600 emery cloth.

If the outside periphery of the commutator has been deflected over 0.2 mm, repair by a lathe.

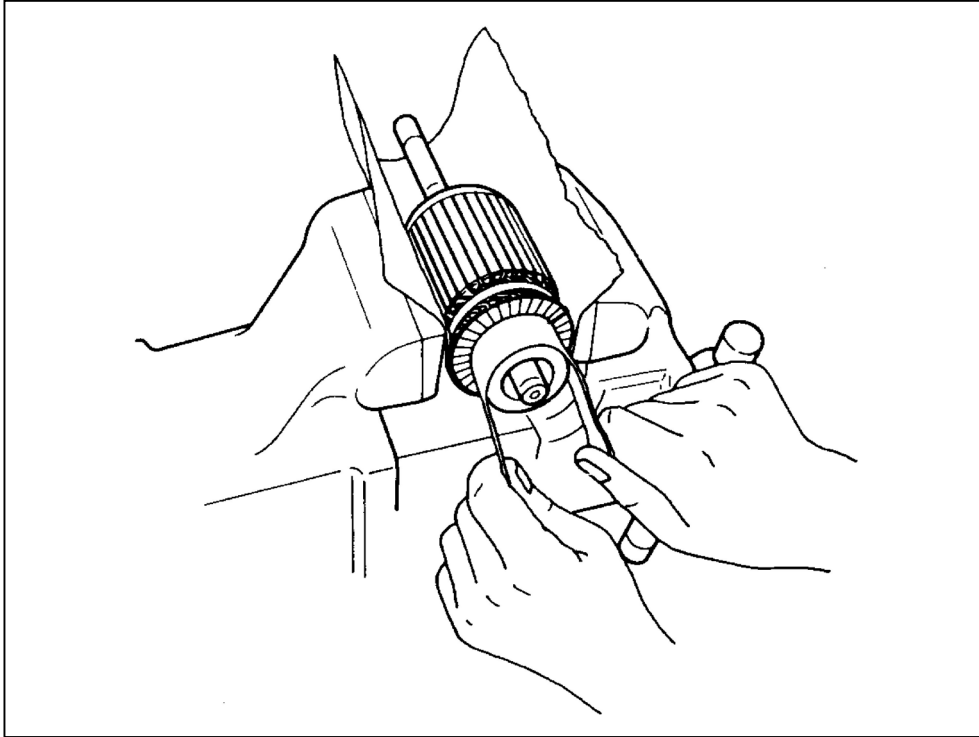

- 2) Measure the depth of the insulating material between commutator segments, and correct if it is less than 0.2 mm.

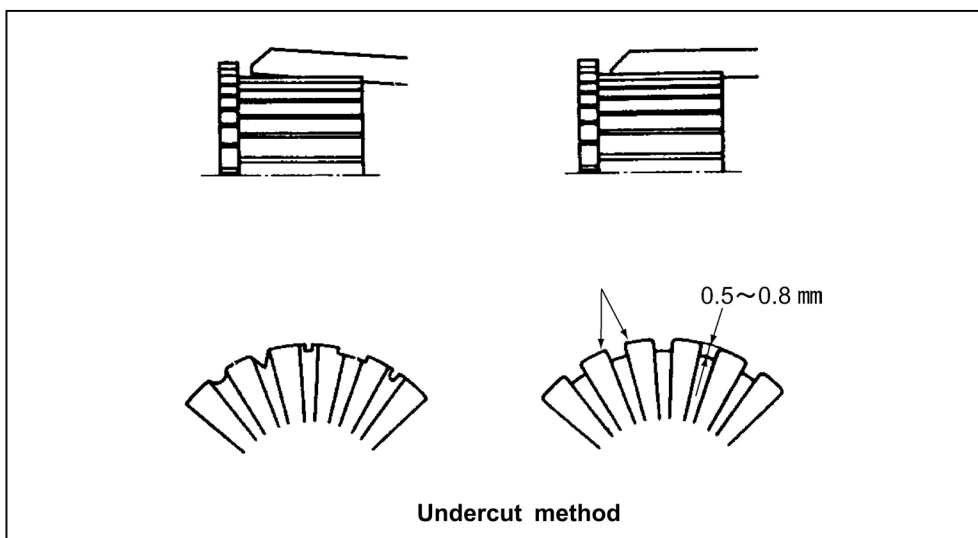

## 3) Armature coil continuity and earth tests

Test type	Measurement point	Normal	Abnormal (cause)
Continuity test	Across commutator	Yes	None (open circuit)
Earth test	Between commutator and shaft or armature	None	Yes (short-circuiting)

Replace if needed.

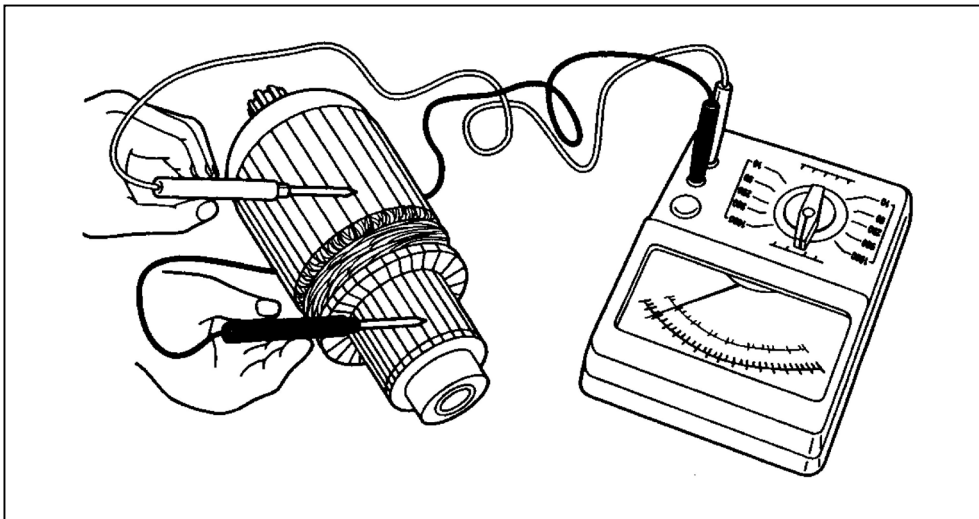
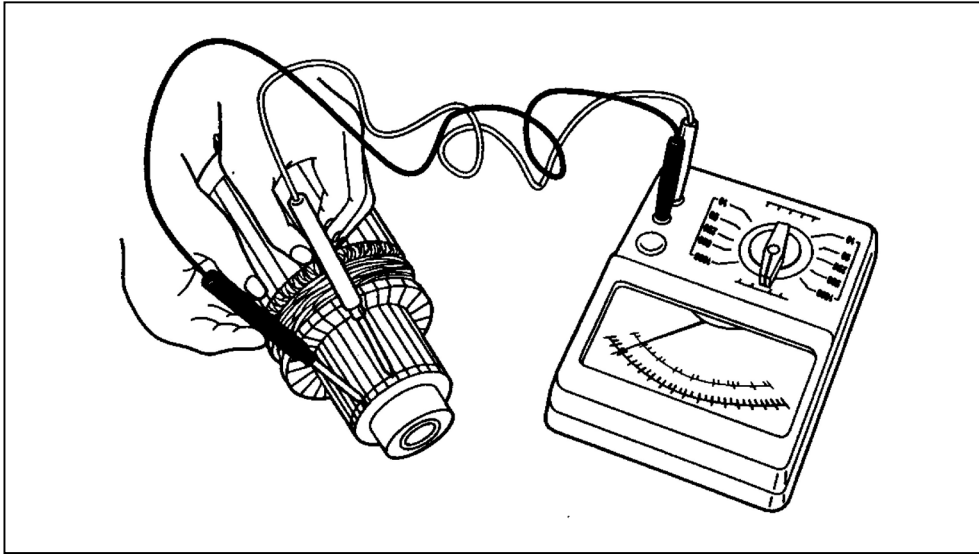

## (2) Field coil

## 1) Field coil continuity and earth tests

Test type	Measurement point	Normal	Abnormal (cause)
Continuity test	Across commutator	Yes	None (open circuit)
Earth test	Between commutator and shaft or armature	None	Yes (short-circuiting)

Replace if needed.

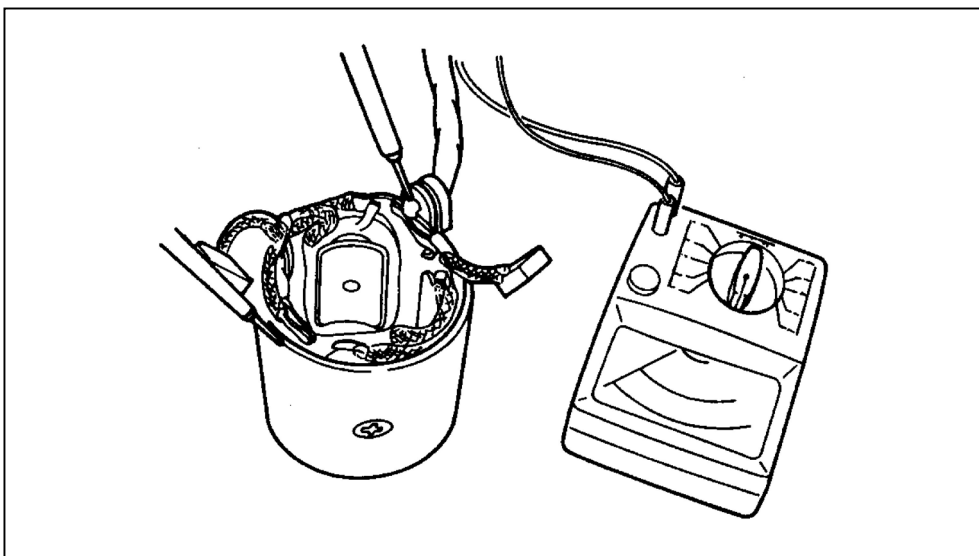
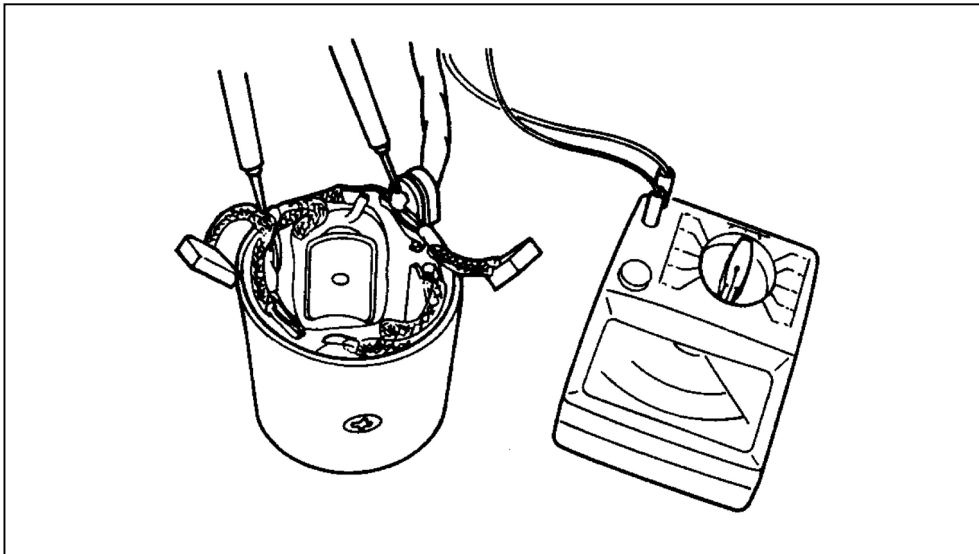

(3) Brush

- 1) Check wear of the brush and the brush spring force.

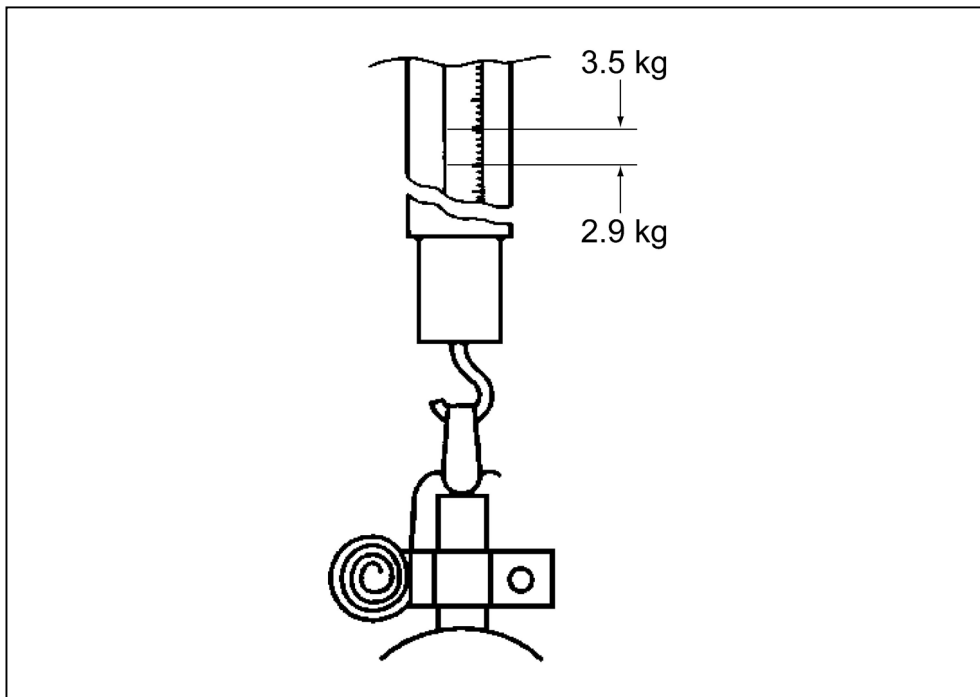
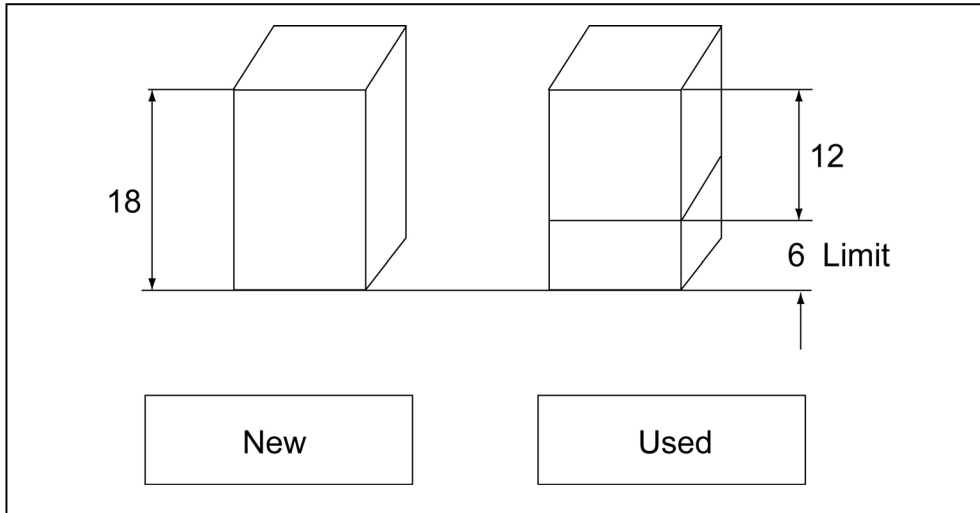

2) Check of brush movement

If the brush does not move smoothly, inspect the brush holder for bending and the brush holder sliding surface for dirt. Repair or clean as needed.

3) Check the continuity between the insulated brush holder (positive (+)) and the brush holder base (negative (-)).

If they are electrically continuous, replace since the holder is grounded.

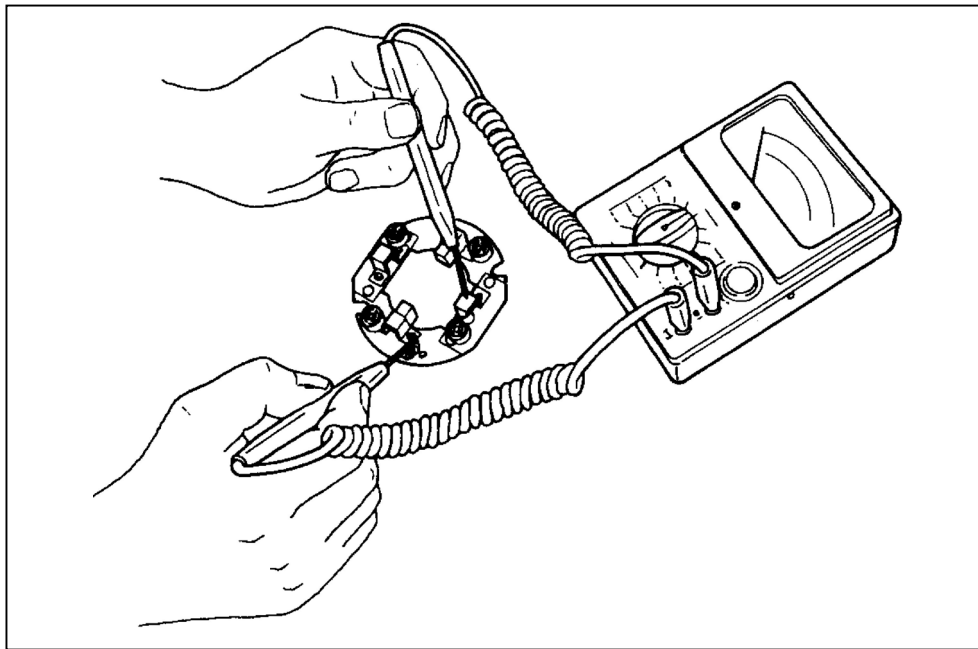

(4) Magnetic switch continuity test

Test type	Measurement point	Normal	Abnormal (cause)
Shunt coil	Between C and ground	Yes	None (open circuit)
Series coil	C and M	None	Yes (short-circuiting)

Replace if needed.

	S13-138 Resistance (at 20°C)
Shunt coil	0.6
Series coil	0.218

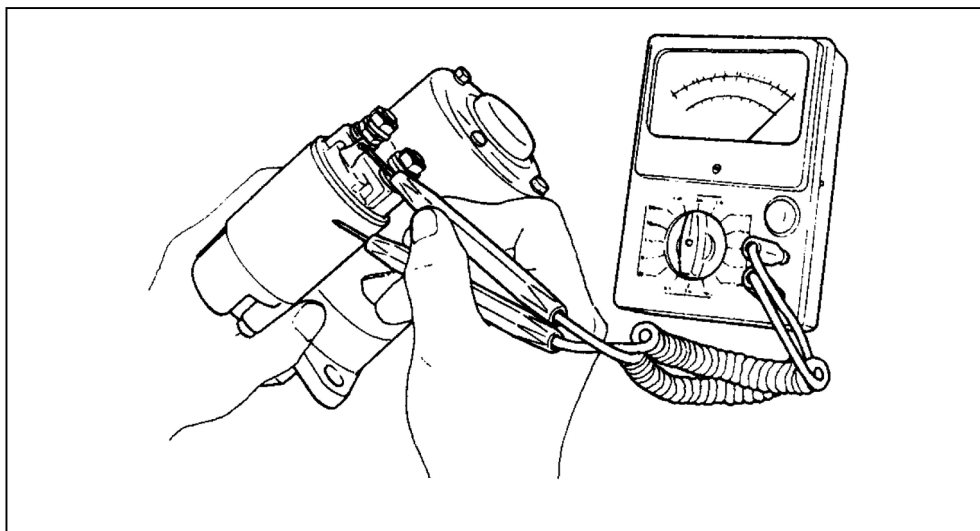
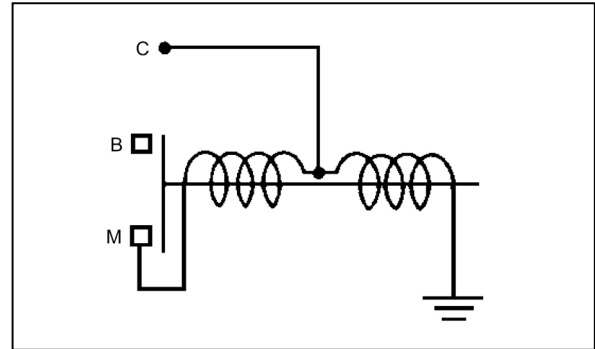

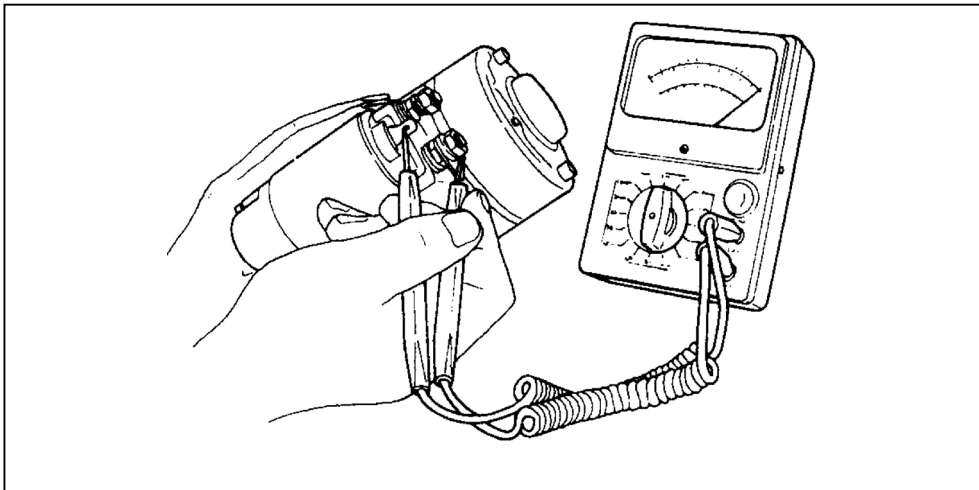
**(5) Pinion**

- 1) Check the pinion teeth for wear and damage. Replace with a new one, if necessary.
- 2) Check if the pinion slides smoothly. If it is damaged or rusted or does not slide smoothly, repair.
- 3) Check springs for damage, and replace if necessary.

**(6) Ball bearing**

If abnormalities such as irregular noises are detected to the ball bearing, replace with a new one.

**9.2.7 Assembly**

The assembly procedure is reverse of the disassembly procedure, but pay attention to the following points.

(1) Apply grease as instructed below.

Greasing point	Grease type
Sliding portions and head of plunger Pinion metal and metal portions of gear case Spline portions of pinion Sliding portions of shift lever	NPC-FC6A Grease
Deceleration gear	MALTEMP SRL Grease

**(2) Armature thrust**

No adjustments are needed for the thrust.

**(3) Gear shaft thrust**

Some thrust washers of 1.0 and 0.25 mm thickness are provided between the center bracket and gear shaft supporting surface. Make sure to check them at reassembly.

If washers are deformed or worn, replace them with new ones.

The appropriate thrust is from 0.05 to 0.3mm. If it is over 0.3mm, and the appropriate thrust washer, but pay attention so that the thrust is not 0.



### 9.2.8 Adjustment

(1) Pinion projection length L by magnetic switch

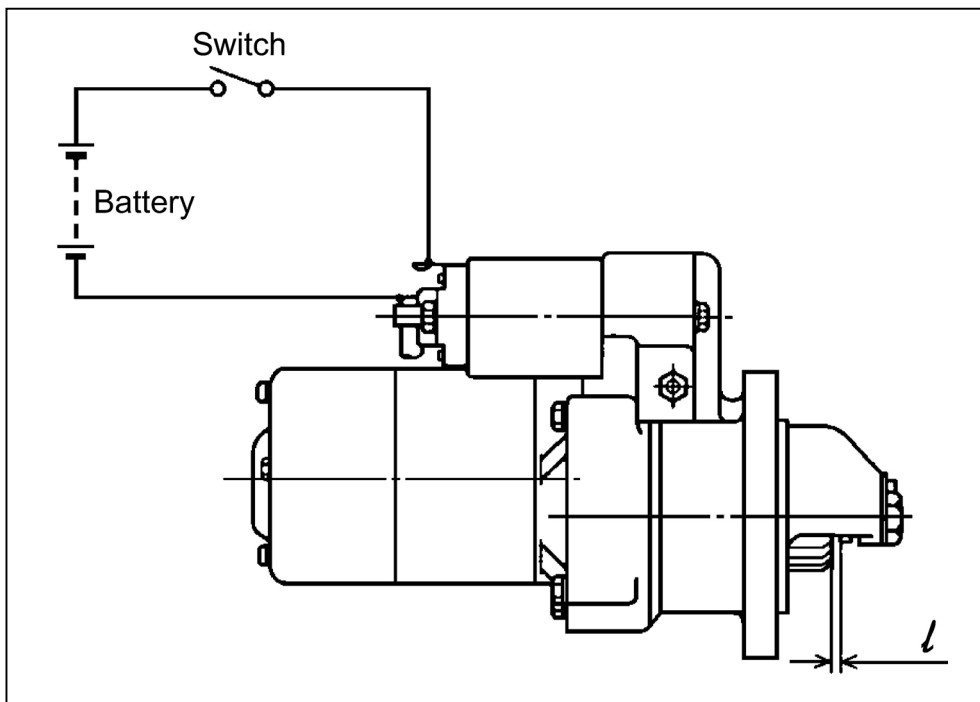
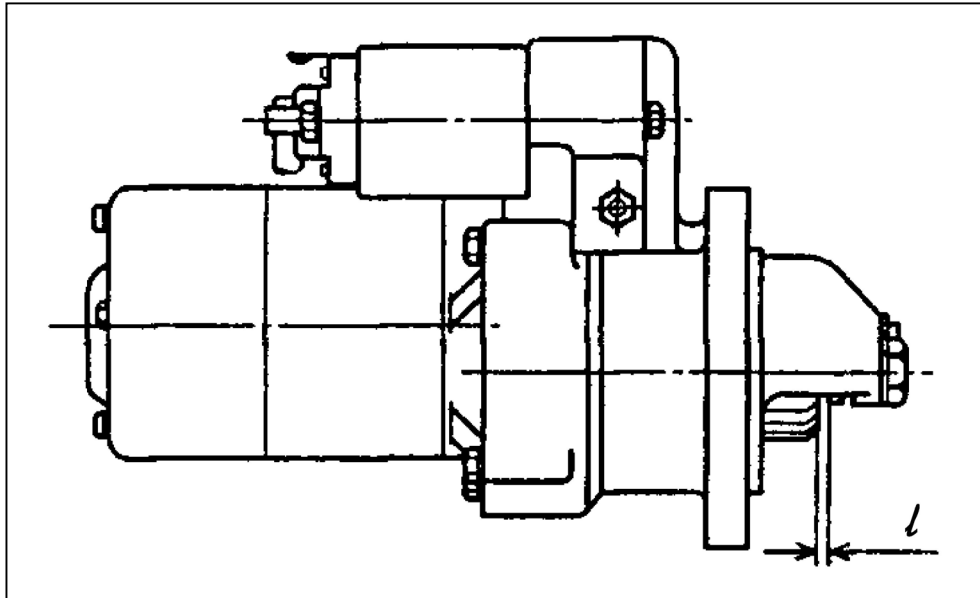

Measure the pinion moving distance L (0.3 to 1.5mm) in the thrust direction when the pinion is protruded by the magnetic switch.

If the distance L is outside the standard range, adjust by the dust cover as shown below.

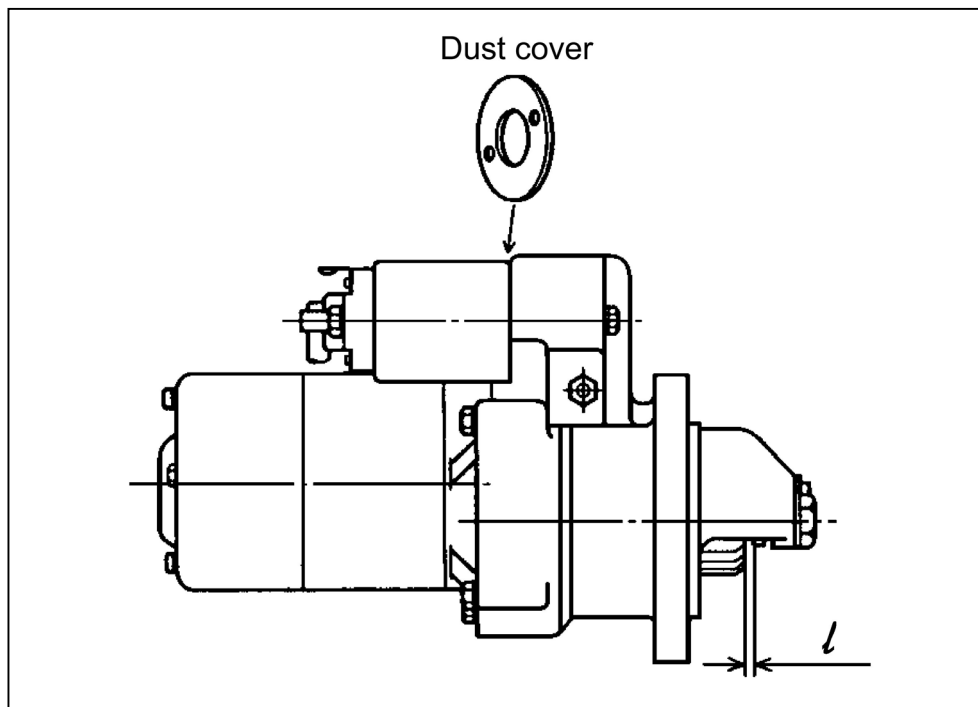

### 9.2.9 Service standards

Brush	Spring force N(kgf)		31.4 (3.2)
	Standard / Limit height		18/6
Commutator	Outside diameter	Standard	37
		Limit	36
	Deflection	Limit	0.2
		Correction accuracy	0.05
Depth of insulation mica	Limit	0.2	
	Correction accuracy	0.5~0.8	
Standard dimensions	Armature shaft diameter	Front	25
		Rear	12
	Bearing on gear case side	Gear shaft diameter	13.95~13.968
		Hole diameter	14.00~14.018
	Sliding portion of pinion	Shaft diameter	13.95~13.968
		Hole diameter	14.03~14.05
Ball bearing	Armature	Front	6905DDU
		Rear	6001DDU
Length L (pinion projection length)			0.3~1.5

## 10. ALTERNATOR

As a representative example of alternator, the alternator of 40A is shown in this chapter.

### 10.1 The 40A Alternator for 3TNV84 and other models

#### 10.1.1 Components

(1) Parts related to the alternator

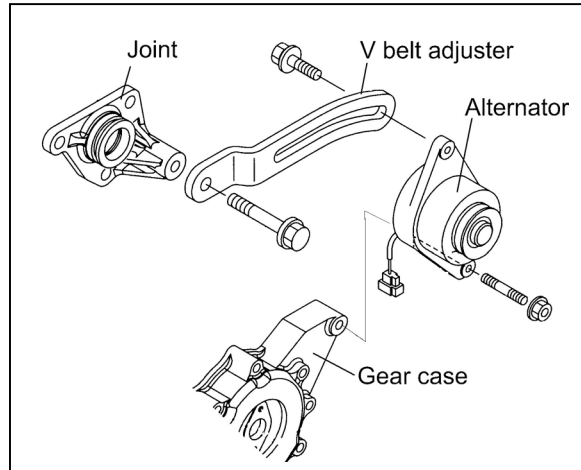

(2) Alternator components of the disassembly and assembly

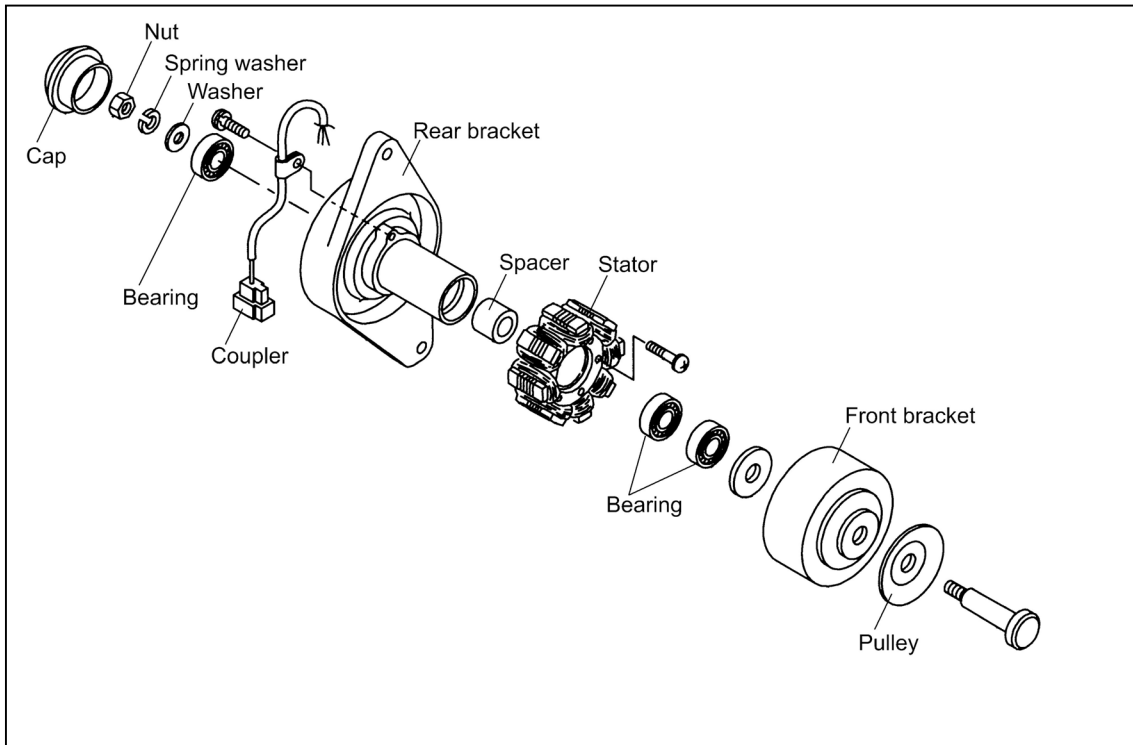

### 10.1.2 Specifications

Manufacturer's model (Hitachi)	-	ACFA68
Yanmar code	-	129423-77200
Rating	-	Continuous
Battery voltage	V	12
Nominal output (13.5V heat)	A	40
Rated revolution	min <sup>-1</sup>	5,000
Operating revolution	min <sup>-1</sup>	1,350~18,000
Grounding characteristics	-	Minus side grounding
Direction of revolution (viewed from pulley)	-	Clockwise
Integrated regulator		IC regulator
Weight	kg	2.8
Pulley (outside diameter)	mm	69.2
Belt shape	-	Type A

### 10.1.3 Wiring diagram

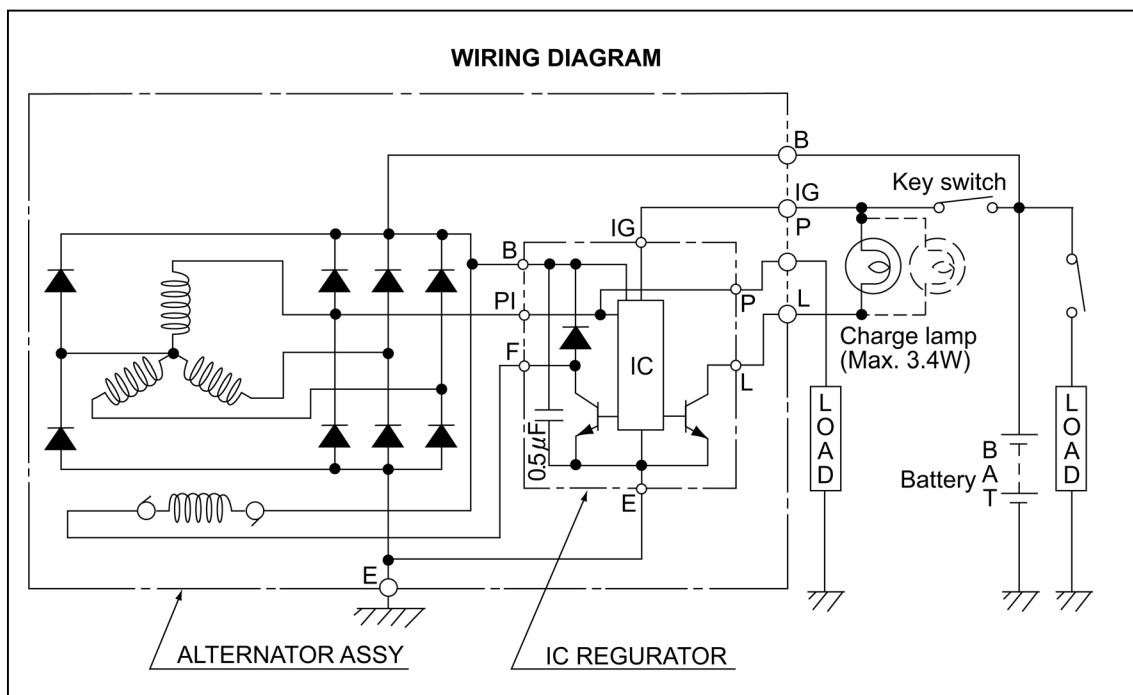

#### [NOTICE]

- 1) Don't do miss-wiring and short-circuit of each terminal.
- 2) Don't short-circuit between IG and L. (Connect it through the charge lamp.)
- 3) Don't connect a load between L and E.
- 4) Don't remove a battery terminal and a B terminal when rotating.
- 5) Shut out a battery switch during the alternator stop.
- 6) Tightening torque of each terminal: 1.7-2.3N·m (17-23kgf·cm)

### 10.1.4 Standard output characteristics

The standard output characteristics of this alternator are shown as the right figure.

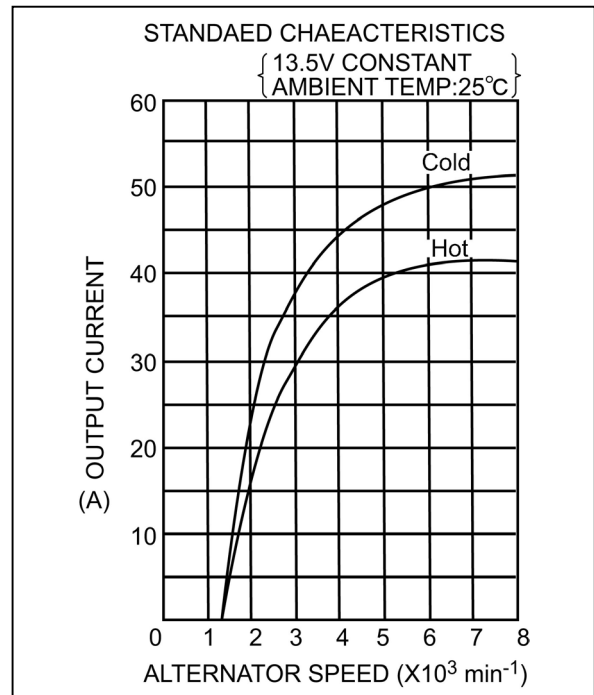

### 10.1.5 Inspection

#### (1) V belt inspection

- 1) Inspect the matter whether there are not crack, stickiness and wear on the belt visually. Check that a belt doesn't touch the bottom part of the pulley groove. If necessary, replace the V belt set.
- 2) V belt tension: (Refer to 2.2.2 in Chapter 2.)

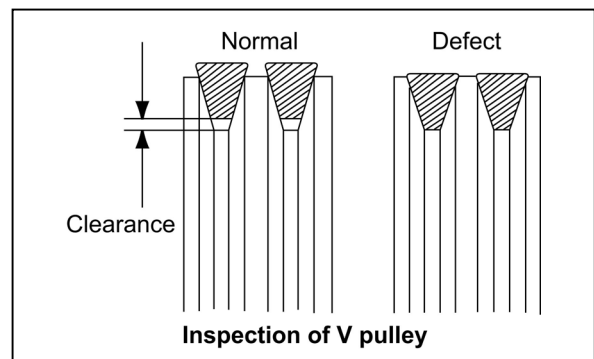

#### (2) Visual check of wiring and check of unusual sound

- 1) Confirm whether wiring is right or there is no looseness of the terminal part.
- 2) Confirm that there is no unusual sound from the alternator during the engine operation.

#### (3) Inspection of charge lamp circuit

- 1) Move a start switch to the position of on. Confirm lighting of the charge lamp.
- 2) Start an engine, and confirm the lights-out of the lamp. Repair a charge lamp circuit when a lamp doesn't work.

### 10.1.6 Troubleshooting

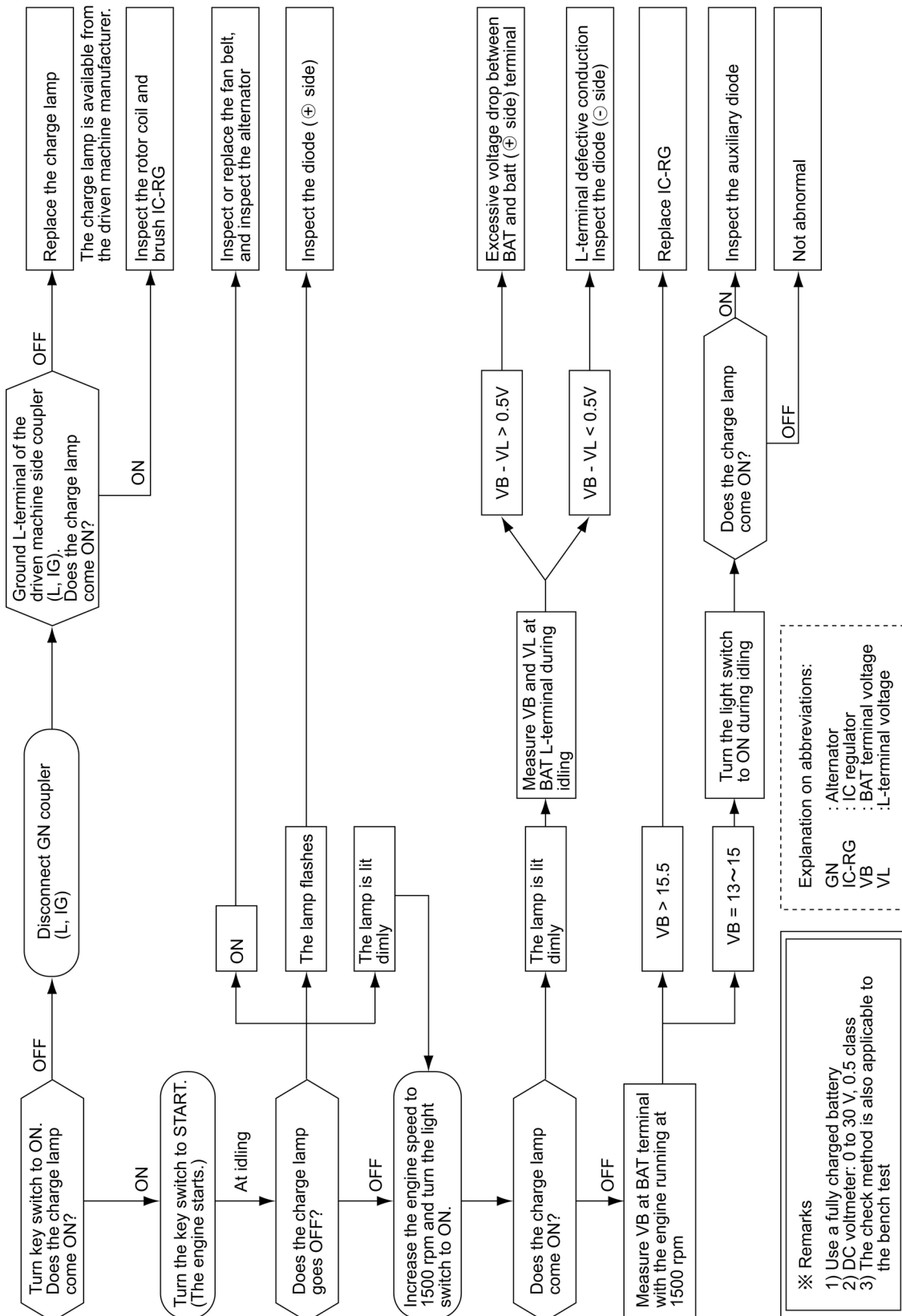

# 11. ELECTRIC WIRING

## 11.1 Electric Wiring Diagram

	B	R1	R2	ACC	C	BR
PRE-HEATING	○	○	○	○	○	○
OFF	○	○	○	○	○	○
ON	○	○	○	○	○	○
START	○	○	○	○	○	○

KEY SW. DIAGRAM

MARK	COLOR
B	Black
W	White
R	Red
L	Blue
G	Green
Y	Yellow
Br	Brown
Lg	Light Green
Sb	Sky blue
O	Orange
P	Pink
Gr	Gray
R/W	Red/White

NOTES

1. WIRING OF STARTER MUST BE OBSERVED AS FOLLOWS. OTHERWISE IT CAUSES MISS STARTING OR DAMAGE OF STARTER MOTOR.
  - 1-1. TOTAL ELECTRIC RESISTANCE OF BATTERY CABLE (①+②) SHOULD BE LESS THAN 2/1000Ω. REFERENCE: AV15: ≤1.4m, AV20: ≤2.2m, AV30: ≤3.8m, AV40: ≤4.6m
  - 1-2. TOTAL ELECTRIC RESISTANCE OF WIRING FOR STARTER (③-⑥) SHOULD BE LESS THAN 5/100Ω. REFERENCE OF TERMINAL RESISTANCE: 15/1000Ω PER COUPLER, 0Ω PER SCREW SETTING
  - 1-3. BATTERY EARTH CABLE (①) CONNECTION SHALL BE ENSURED. PAINTED SURFACE MAY NOT BE USED (FOR EARTHING) AVOIDING THE MISS CONTACT.
2. BATTERY TREATMENT MUST BE OBSERVED AS FOLLOWS. OTHERWISE IT MAY CAUSE BURNING OF ELECTRIC EQUIPMENTS OR COMPONENTS. ALTERNATOR (DIODES) BURNING CAUSED BY BATTERY CABLE CONNECTION REVERSELY IS NOT WARRANTED.
  - 2-1. BATTERY SHOULD BE FIXED BY FITTING. (NOT TO MOVE)
  - 2-2. BATTERY CABLE LENGTH SHOULD BE ADJUSTED PROPERLY AND CLAMPED NOT TO BE CONNECTED REVERSELY.
  - 2-3. NOT LOOSE THE BATTERY CABLE TERMINAL, NOR TURN THE BATTERY SWITCH OFF DURING THE ENGINE RUNNING.
3. ONLY THE SPECIFIED LOAD SHOULD BE APPLIED ON THE ALTERNATOR "L" AND "P" LINE. IT IS NOT ALLOWED TO CONNECT ANY LOAD UNSPECIFIED WITHOUT YANMAR APPROVAL.
4. CHECK ANY SURGE CURRENT OR VOLTAGE OCCURED UNDER NORMAL OPERATIONS AND EXPECTIVE ERRONEOUS OPERATIONS, AND CONFIRM THE CIRCUIT NO SURGE OCCURS. ESPECIALLY PROVIDE THE FLYWHEEL DIODE FOR "C-LOAD" AND DIODE FOR "L-LOAD".

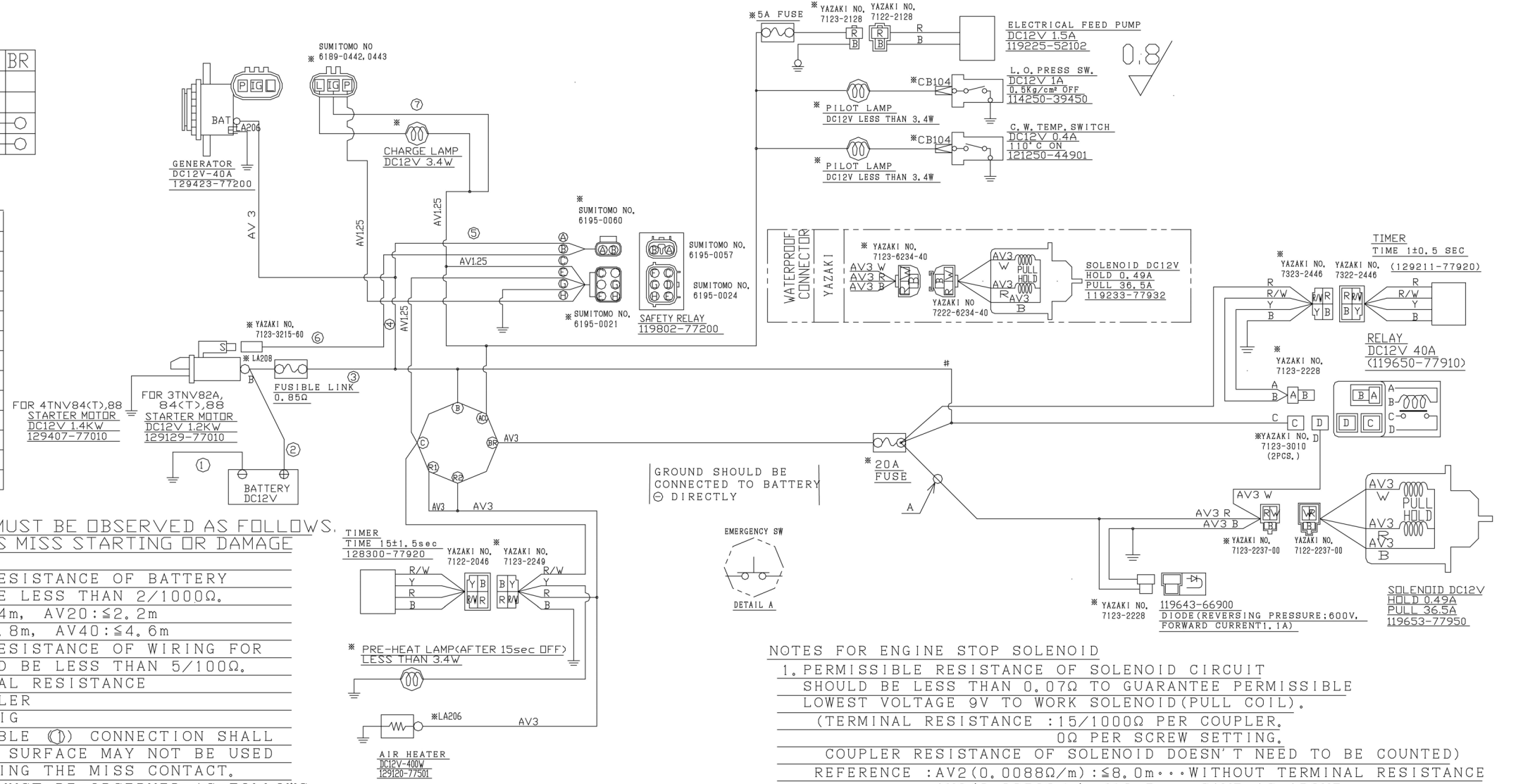

GROUND SHOULD BE CONNECTED TO BATTERY DIRECTLY



NOTES FOR ENGINE STOP SOLENOID

1. PERMISSIBLE RESISTANCE OF SOLENOID CIRCUIT SHOULD BE LESS THAN 0.07Ω TO GUARANTEE PERMISSIBLE LOWEST VOLTAGE 9V TO WORK SOLENOID (PULL COIL). (TERMINAL RESISTANCE: 15/1000Ω PER COUPLER, 0Ω PER SCREW SETTING. COUPLER RESISTANCE OF SOLENOID DOESN'T NEED TO BE COUNTED) REFERENCE: AV2 (0.0088Ω/m): ≤8.0m... WITHOUT TERMINAL RESISTANCE, AV3 (0.0056Ω/m): ≤12.5m... SAME AS ABOVE. WHEN YOU EXCEED PERMISSIBLE RESISTANCE, ADOPT THE CIRCUIT IMPRESSED FROM THE POWER SUPPLY TO THE SOLENOID DIRECTLY USING A RELAY... REFER TO #
2. HIGH TEMPERATURE PARTS, SUCH AS AN EXHAUST PIPE, SHOULD NOT APPROACH FOR THE PULL POWER FALL OF SOLENOID, AND HEATING PREVENTION OF INNER COIL TEMPERATURE. (PERMISSIBLE AMBIENT TEMPERATURE: -30~100°C)
3. INSTALL FUSE TO PROTECT THE HARNESS AGAINST TROUBLES SUCH AS SHORT CIRCUIT OR CONTINUOUS DRIVE OF PULL-COIL.
4. THE POWER SUPPLY OF SOLENOID MAY NOT BE COMMON WITH THE LINE OF ALTERNATOR INITIAL EXCITATOR AS SHOWN IN THIS DRAWING. (OTHERWISE, SOLENOID MAY LOOSE STOP FUNCTION DUE TO THE POWER SUPPLY FROM ALTERNATOR "L" TERMINAL.)
5. IN CASE OF WATERPROOF CONNECT OR APPLICATION, CONNECTOR SHOULD BE FIXED BY FITTING TO PREVENT LEAD WIRE BREAK.
6. IN CASE OF EMERGENCY STOP OF MACHINE FOR SAFETY WILL BE APPLIED, SWITCH LOCATION SHOULD BE SHOWN AS A.
7. IN CASE OF THE SOLENOID CIRCUIT RESISTANCE WOULD BE LIMIT, # WIRING IS APPLICABLE.

REMARKS

1. \* MARKED PARTS ARE NOT PROVIDED BY YANMAR.

## 11.2 PRECAUTION ON ELECTRIC WIRING

### 11.2.1 Alternator

In the cases listed below the warranty shall not be deemed to apply. Please be sure to read these conditions carefully when planning to use it with other equipment. Also be certain to give appropriate guidance on usage to the user.

#### (1) When the battery cable can be connected backwards

The alternator diode will be damaged and recharging made impossible if the plus and minus ends of the battery cable are confused. The stator coil will also be burned as a result. To prevent this, supply the user with a cable of such a length or structure that the plus and minus ends cannot be confused. Also warn the user not to connect the cable backwards.

#### (2) When charging output voltage is used for control purposes

The engine speed at starting is not proportional to the output voltage of the alternator, so this output voltage must not be used for any control systems. It is especially wrong to use it for the control signal of the safety relay for cutting the starter motor because this will damage the starter motor and cause engine starting failure.

#### (3) When the L line is used for control purposes

Consult with Yanmar first before connecting any load other than the charge lamp to the L line. Damage to the alternator and related equipment will not be warranted without such prior consultation.

#### (4) Non-use of the Yanmar wiring diagram

Use without prior consultation of any wiring diagram other than that provided by Yanmar removes any breakdown of any electrical equipment from the warranty.

#### (5) Regarding lamp control

Once the charge lamp goes out after the start of charging, it does not come on again even if the engine speed falls and charging is insufficient. The lamp will not light again if the charging circuit is normal. The lamp only comes on during operation if the alternator itself is broken or the drive V-belt breaks. However, when an LED is used for the charge lamp, the LED will shine faintly even during normal operation. This is due to the control system for the alternator lamp and is not an abnormality.

#### (6) Use of a non-specified V-belt

Use of a non-specified V-belt will cause inadequate charging and shorten the life of the belt. Use a belt of the specified type.

#### (7) Direct high pressure washing is prohibited

Water will enter the brush if the alternator is washed directly at high pressure, causing inadequate charging. Warn users not to use direct, high-pressure washing.

#### (8) Use of agricultural or other chemicals (direct contact or airborne)

Adhesion of agricultural and other chemicals, especially those with high sulfur content, to the IC regulator corrodes the conductor on the substrate, leading to over-charging (battery boiling) and charging malfunctions. Consult with Yanmar prior to use in such an environment. Use without prior consultation removes any breakdown from the warranty.



## 11.2.2 Starter

In the cases listed below the warranty shall not be deemed to apply. Please be sure to read these conditions carefully when planning to use it with other equipment. Also be certain to give appropriate guidance on usage to the user.

### (1) Starting performance in the case of using an untested battery

The starting performance of the engine is closely dependent on the battery capacity. This battery capacity is itself affected by the climate and the type of equipment installation. The details regarding ambient temperature and equipment installation vary depending on the OEM, so Yanmar cannot decide the battery capacity on its own. Confer with Yanmar in advance after checking these conditions and fix the battery capacity on the basis of confirmatory tests.

### (2) When the resistance of the battery cable exceeds the specified value

The combined total resistance of the battery cable in both directions between the starting motor and battery should be within the value indicated on the wiring diagram. The starting motor will malfunction or break down if the resistance is higher than the specified value.

### (3) When the resistance of the starter circuit exceeds the specified value

The combined total resistance of the wiring between the starting motor and key switch (or power relay or safety relay, depending on the application) should be within the value indicated on the wiring diagram. Engine starting will be difficult if the resistance is higher than the specified value. This can also cause welding of the magnet switch at the point of contact and resultant burning of the armature coil.

### (4) When there is no safety relay

Over-running (when the electric current flows for too long) is a major cause of starting failure. This burns the armature coil and causes clutch failure. Excessive work and failure of the key switch to return properly are the main causes of over-running. The user must be given sufficient warning about this.

Be sure to use the safety relay to prevent over-running. This safety relay is supplied as an option. Consult Yanmar first when planning to install a safety relay at your own company. In the case of failure to consult with Yanmar, our warranty will not be applied to all the electrical equipment.

### (5) When there is too much rust due to the entry of water

The water-proofing of the starting motor is equivalent to R2 of JIS D 0203. This guarantees that there will be no damage from the sort of exposure encountered in rain or when water is poured on from a bucket. You should, however, avoid the use of high-pressure washing and steeping in water.

### (6) Regarding the heat resistance of the starter motor

The starter motor has heat resistance for an ambient temperature of 80°C and surface temperature of 100°C. Insulators must be installed to prevent overheating when used near high temperature parts such as the exhaust system.

### (7) Corrosion of magnet switch contact point by corrosive gas.

When using equipment with a dry clutch, ammonium gas generated by friction is liable to corrode the contact of the magnet switch. Be sure to install a vent in the clutch case.

### 11.2.3 Current limiter

In the cases listed below the warranty shall not be deemed to apply. Please be sure to read these conditions carefully when planning to use it with other equipment. Also be certain to give appropriate guidance on usage to the user.

#### (1) When an over-discharged battery is used

Use of booster starting with an over-discharged battery (when the voltage has dropped to 8V or less) will destroy other electrical equipment by generating an abnormally high voltage. A specialized battery charger should be used to recharge such an over-discharged battery (when the voltage has dropped to 8V or less).

#### (2) When checks for malfunctioning are not performed

When high voltage noise from other electrical equipment is impressed on the current limiter upon turning off the key switch, the current limiter can be damaged and cause loss of control over the output voltage. Other electrical equipment may also be damaged if this happens, so surge killers should be fitted to the electrical equipment whenever necessary. Be sure to check prior to mass production whether electrical noise might damage the current limiter by turning the key switch and other electrical equipment on and off while the engine is running, using both the vehicle and the wire harness that will be used in mass production.

#### (3) Removal of the battery cable during operation

The current limiter may malfunction if the battery cable and/or battery are removed during operation, depending on the kind of electrical equipment being used, causing loss of control over the output voltage. In such cases, the current limiter and other electrical equipment will be damaged by the generation of a continuous high voltage of 24-43V (for 5,000rpm dynamo). All electrical equipment falls outside the scope of the warranty under these circumstances. Be sure to warn the user not to remove the battery cable and/or battery during operation.

#### (4) If the battery cable can be attached in reverse

The current limiter's SCR diode will be destroyed if the plus and minus ends of the battery cable are connected the wrong way around. This causes charging malfunctioning and burns the harness. Give the user a cable of such a length that it cannot be connected the wrong way and warn the user against connecting the cable backwards.

#### (5) Non-use of the Yanmar wiring diagram

Use without prior consultation of any wiring diagram other than that provided by Yanmar removes any breakdown of any electrical equipment from the warranty.

#### (6) Installation environment

Observe the following when installing the current limiter:

- 1) Do not install it on the engine.
- 2) Place it in a well-ventilated place with an ambient temperature of 65°C or less.
- 3) Ensure that the cooling air flows in the right direction for the current limiter's cooling fins.
- 4) Do not use the earth wire of the current limiter to earth any other electrical equipment.

### 11.2.4 Section area and resistance of electric wire

(1) Allowable maximum cable length (Terminal resistance is not included.)

Cable size mm <sup>2</sup>	Cable construction		Resistance (Ω/m)	2mΩ <sup>Note1</sup> (m)	20mΩ <sup>Ref.</sup> (m)	50mΩ <sup>Note2</sup> (m)
	Element No.	Cable dia.				
3	41	φ0.32	0.005590	0.36	3.58	8.94
5	65	φ0.32	0.003520	0.57	5.68	14.20
8	50	φ0.45	0.002320	0.86	8.62	21.55
15	84	φ0.45	0.001380	1.45	14.49	36.23
20	41	φ0.80	0.000887	2.25	22.55	56.37
30	70	φ0.80	0.000520	3.85	38.46	96.15
40	85	φ0.80	0.000428	4.67	46.73	116.82
50	108	φ0.80	0.000337	5.93	59.35	148.37
60	127	φ0.80	0.000287	6.97	69.69	174.22
85	169	φ0.80	0.000215	9.30	93.02	232.56
100	217	φ0.80	0.000168	11.90	119.05	297.62

Note1) Allowable maximum resistance of Battery cable

Note2) Allowable maximum resistance of Starting motor circuit

#### (2) Terminal resistance

Generally, a terminal resistance is 15mΩ per coupler and 0Ω per screw setting. This resistance should be included in allowable maximum resistance when the cable length is planned.

## 12. SERVICE STANDARDS

### 12.1 Engine Tuning

No.	Inspection item		Standard		Limit	Reference page
1	Gap at intake/exhaust valve heads mm		TNV82A~98	0.15~0.25	-	2.2.6(4)
			4TNV106(T)	0.25~0.35	-	
2	V-belt tension mm at 98N (10kgf)	Between alternator and crank pulley	Used part	10~14	-	2.2.2.(2)
			New part	8~12	-	
		Between alternator and radiator fan	Used part	7~10		
			New part	5~8		
Between radiator fan and crank pulley	Used part	9~13				
	New part	7~11				
3	Fuel injection pressure MPa (kgf/cm <sup>2</sup> )	3TNV82A~TNV88(VM) 4TNV94L~106(T)	21.57~22.55 (220~230)	-	2.2.6.(3)	
		3TNV82A~TNV88(CL)	19.6~20.6 (200~210)			
4	Compression pressure (at 250 min <sup>-1</sup> ) MPa (kgf/cm <sup>2</sup> )	TNV82A	3.16(31)±0.1(1)	2.45(25)±0.1(1)	3.3	
		TNV84	3.24(33)±0.1(1)	2.55(26)±0.1(1)		
		3/4TNV84T	2.94(30)±0.1(1)	2.45(25)±0.1(1)		
		TNV88-106	3.43(35)±0.1(1)	2.75(28)±0.1(1)		
5	Coolant water Capacity (Only engine body) (Liter)	3TNV82A,84	1.8	-	2.2.1.(4)	
		3TNV84T,88	2.0	-		
		4TNV84(T),88	2.7	-		
		4TNV94L·98(T)	4.2	-		
		4TNV106(T)	6.0	-		
6	Lubricating oil capacity (oil pan) (Liter)	-	Full	Effective	-	2.2.1.(3)
		3TNV82A	5.5	1.9	-	
		3TNV84(T)/88	6.7	2.8	-	
		4TNV84(T)/88	7.4	3.4	-	
		4TNV94L/98(T)	10.5	4.5	-	
		4TNV106(T) (CL class)	14.0	9.0	-	
		4TNV106(T) (VM class)	14.0	7.5	-	
7	Lubricating oil pressure MPa (kgf/cm <sup>2</sup> )	-	at rated speed		at low idle speed	-
		3TNV82A~98	0.29(3.0)~0.39(4.0)		0.06(0.6) or above	-
		4TNV98T 4TNV106(T) (VM, WO balancer)	0.39(4.0)~0.49(5.0)			
		4TNV106(T) (CL, WO balancer)	0.31(3.2)~0.49(5.0)			
		4TNV106(T) (VM, W balancer)	0.34(3.5)~0.44(4.5)			
8	Oil pressure switch operating pressure MPa (kgf/cm <sup>2</sup> )	0.05±0.01 (0.5±0.1)		-	-	
9	Thermostat		valve opening temperature deg. C	Full opening lift (mm) (temperature)	2.7	
		All models	69.5~72.5	8 or above (85 deg.C)		
		All models option	80~84	10 or above (95 deg.C)		
10	Thermo switch actuating temperature (deg.C)	107~113		-	2.4.2	

## 12.2 Engine Body

### 12.2.1 Cylinder head

#### (1) Cylinder head

Inspection item		Standard	Limit	Reference page	
Combustion surface distortion		mm	0.05 or less	0.15	4.2.5.(1)
Valve sink	3TNV82A (2-valve head)	Intake	0.35~0.55	0.8	
		Exhaust	0.30~0.50	0.8	
	TNV84~88 (2-valve head) 4TNV84T(4-valve)	Intake	0.30~0.50	0.8	
		Exhaust	0.30~0.50	0.8	
	4TNV94L·98(T) (4-valve head)	Intake	0.36~0.56	0.8	
		Exhaust	0.35~0.55	0.8	
	4TNV106(T) (4-valve head)	Intake	0.5~0.7	1.0	
		Exhaust	0.7~0.9	1.2	
Valve seat (2-valve, 4-valve)	Seat angle Deg.	Intake	120	-	
		Exhaust	90	-	
	Seat correction angle	deg.	40, 150	-	

## (2) Intake/exhaust valve and guide

mm

Inspection item		Standard	Limit	Reference page	
3TNV82A (2-valve head)	Intake	Guide inside diameter	7.000~7.015	7.08	4.2.5.(2)
		Valve stem outside diameter	6.945~6.960	6.90	
		Clearance	0.040~0.070	0.18	
	Exhaust	Guide inside diameter	7.000~7.015	7.08	
		Valve stem outside diameter	6.940~6.955	6.90	
		Clearance	0.045~0.075	0.18	
4TNV84 3TNV84(T) 3/4TNV88 (2-valve head)	Intake	Guide inside diameter	8.010~8.025	8.10	
		Valve stem outside diameter	7.955~7.975	7.90	
		Clearance	0.035~0.070	0.18	
	Exhaust	Guide inside diameter	8.015~8.030	8.10	
		Valve stem outside diameter	7.955~7.960	7.90	
		Clearance	0.045~0.075	0.18	
4TNV84T (4-valve head)	Intake	Guide inside diameter	6.000~6.015	6.08	
		Valve stem outside diameter	5.960~5.975	5.90	
		Clearance	0.025~0.055	0.15	
	Exhaust	Guide inside diameter	6.000~6.015	6.08	
		Valve stem outside diameter	5.945~5.960	5.90	
		Clearance	0.040~0.070	0.17	
4TNV94L 4TNV98(T) (4-valve head)	Intake	Guide inside diameter	7.000~7.015	7.08	
		Valve stem outside diameter	6.945~6.960	6.90	
		Clearance	0.040~0.070	0.17	
	Exhaust	Guide inside diameter	7.000~7.015	7.08	
		Valve stem outside diameter	6.940~6.955	6.90	
		Clearance	0.045~0.075	0.17	
4TNV106(T) (4-valve head)	Intake	Guide inside diameter	7.008~7.020	7.08	
		Valve stem outside diameter	6.945~6.960	6.92	
		Clearance	0.048~0.075	0.16	
	Exhaust	Guide inside diameter	7.008~7.020	7.08	
		Valve stem outside diameter	6.960~6.975	6.90	
		Clearance	0.033~0.060	0.18	
Valve guide projection from cylinder head	3TNV82A		11.7~12.0	-	4.2.7.
	4TNV84, 3TNV84(T), 4TNV88		14.7~15.0	-	
	4TNV84T		8.2~8.5	-	
	4TNV94L, 4TNV98(T)		9.7~10.0	-	
	4TNV106(T)		13.4~13.6	-	
Valve guide driving-in method		Cold-fitted	-		

(3) Valve spring

				mm
Inspection item		Standard	Limit	Reference page
Free length	3TNV82A (2-valve)	44.4	43.9	4.2.5.(4)
	4TNV84,3TNV84(T), 4TNV88 (2-valve)	42.0	41.5	
	4TNV84T (4-valve)	37.4	36.9	
	4TNV94L, 4TNV98(T), (4-valve)	39.7	39.2	
	4TNV106(T) (4-valve)	50.6	50.1	
Inclination	3TNV82A (2-valve)	-	1.4	
	4TNV84, 3TNV84(T), 4TNV88 (2-valve)	-	1.4	
	4TNV84T (4-valve)	-	1.3	
	4TNV94L, 4TNV98(T), (4-valve)	-	1.4	
	4TNV106(T) (4-valve)	-	1.5	

(4) Rocker arm and shaft

				mm
Model	Inspection item	Standard	Limit	Reference page
TNV82A~88	Arm shaft hole diameter	16.000~16.020	16.07	4.2.5.(5)
	Shaft outside diameter	15.966~15.984	15.94	
	Clearance	0.016~0.054	0.13	
4TNV94L/98(T)/106(T)	Arm shaft hole diameter	18.500~18.520	18.57	
	Shaft outside diameter	18.470~18.490	18.44	
	Clearance	0.010~0.050	0.13	

(5) Push rod

				mm
Inspection item	Standard	Limit	Reference page	
Bend	-	0.03	4.2.5.(7)	

## 12.2.2 Gear train and camshaft

### (1) Camshaft

mm

Inspection item		Standard	Limit	Reference page	
Side gap		0.05~0.20	0.30	4.3.4	
Bending (1/2 the dial gage reading)		0~0.02	0.05	4.3.5(1)	
Cam height	3TNV82A-TNV88	38.600~38.800	38.350		
	4TNV94L·98	43.400~43.600	43.150		
	4TNV106(T)	50.900~51.100	50.650		
Shaft outside diameter / Metal inside diameter					
TNV82A~TNV88	Gear side	Bushing inside diameter	44.990~45.055	45.130	4.3.5(1)
		Camshaft outside diameter	44.925~44.950	44.890	
		Clearance	0.040~0.130	0.240	
	Intermediate	Bushing inside diameter	45.000~45.025	45.100	
		Camshaft outside diameter	44.910~44.935	44.875	
		Clearance	0.065~0.115	0.225	
	Wheel side	Bushing inside diameter	45.000~45.025	45.100	
		Camshaft outside diameter	44.925~44.950	44.890	
		Clearance	0.050~0.100	0.210	
4TNV94L/98(T)	Gear side	Bushing inside diameter	49.990~50.055	50.130	
		Camshaft outside diameter	49.925~49.950	49.890	
		Clearance	0.040~0.130	0.240	
	Intermediate	Bushing inside diameter	50.000~50.025	50.100	
		Camshaft outside diameter	49.910~49.935	49.875	
		Clearance	0.065~0.115	0.225	
	Wheel side	Bushing inside diameter	50.000~50.025	50.100	
		Camshaft outside diameter	49.925~49.950	49.890	
		Clearance	0.05~0.100	0.210	
4TNV106(T)	Gear side	Bushing inside diameter	57.980~58.050	58.105	
		Camshaft outside diameter	57.910~57.940	57.875	
		Clearance	0.040~0.140	0.250	
	Intermediate	Bushing inside diameter	58.000~58.030	58.105	
		Camshaft outside diameter	57.895~57.925	57.860	
		Clearance	0.075~0.135	0.245	
	Wheel side	Bushing inside diameter	58.000~58.030	58.105	
		Camshaft outside diameter	57.910~57.940	57.875	
		Clearance	0.050~0.120	0.230	



## (2) Idle gear shaft and bushing

Inspection item	Standard	Limit	Reference page
Shaft outside diameter	45.950~45.975	45.900	4.3.5(2)
Bushing inside diameter	46.000~46.025	46.075	
Clearance	0.025~0.075	0.175	

## (3) Backlash of each gear

Model	Inspection item	Standard	Limit	Reference page
3TNV82A~88	Crank gear, cam gear, idle gear, fuel injection pump gear and PTO gear	0.07~0.15	0.17	4.3.4.
4TNV94L 4TNV98(T) 4TNV106(T)	Crank gear, cam gear, idle gear, fuel injection pump gear and PTO gear	0.08~0.14	0.16	
	Lubricating oil pump gear	0.09~0.15	0.17	
	Balancer drive gear (only for 4TNV106(T))	0.12~0.18	0.20	

**12.2.3 Cylinder block**

## (1) Cylinder block

Inspection item		Standard	Limit	Reference page
Cylinder inside diameter	3TNV82A	82.000~82.030	82.200	4.4.5.(1)
	TNV84	84.000~84.030	84.200	
	TNV88	88.000~88.030	88.200	
	4TNV94L	94.000~94.030	94.130	
	4TNV98	98.000~98.030	98.130	
	4TNV106(T)	106.000~106.030	106.130	
Cylinder bore	Roundness	0.01 or less	0.03	
	Inclination			

## (2) Crankshaft

			mm		Reference page
Inspection item			Standard	Limit	
Bending (1/2 the dial gauge reading)			-	0.02	4.4.5.(2)
Crank pin	3TNV82A	Pin outside diameter	42.952~42.962	42.902	
		Metal inside diameter	43.000~43.042	-	
		Metal thickness	1.487~1.500	-	
		Clearance	0.038~0.090	0.150	
	TNV84~88	Pin outside diameter	47.952~47.962	47.902	
		Metal inside diameter	48.000~48.026	-	
		Metal thickness	1.492~1.500	-	
		Clearance	0.038~0.074	0.150	
	4TNV94L·98	Pin outside diameter	57.952~57.962	57.902	
		Metal inside diameter	58.000~58.026	-	
		Metal thickness	1.492~1.500	-	
		Clearance	0.038~0.074	-	
	4TNV106(T)	Pin outside diameter	63.952~63.962	0.150	
		Metal inside diameter	64.016~64.042	63.902	
		Metal thickness	1.984~1.992	-	
		Clearance	0.054~0.090	0.150	
Crank journal	3TNV82A	Journal outside diameter	46.952~46.962	46.902	
		Metal inside diameter	47.000~47.032	-	
		Metal thickness	1.987~2.000	-	
		Clearance	0.038~0.080	0.150	
	TNV84~88	Journal outside diameter	53.952~53.962	53.902	
		Metal inside diameter	54.000~54.020	-	
		Selective pairing Metal thickness	1.995~1.990	-	
		Clearance	0.038~0.068	0.150	
	4TNV94L·98	Journal outside diameter	64.952~64.962	64.902	
		Metal inside diameter	65.000~65.020	-	
		Selective pairing Metal thickness	1.995~2.010	-	
		Clearance	0.038~0.068	0.150	
	4TNV106(T)	Journal outside diameter	75.952~75.962	75.902	
		Metal inside diameter	76.014~76.034	-	
		Selective pairing Metal thickness	2.488~2.503	-	
		Clearance	0.052~0.082	0.150	

(3) Thrust bearing

Inspection item		Standard	Limit	Reference page
Crankshaft side gap	All models	0.13~0.23	0.28	4.4.4

mm

(4) Piston and ring

Piston

Inspection item		Standard	Limit	Reference page
Piston outside diameter (Measure in the direction vertical to the piston pin.)	3TNV82A	81.950~81.980	81.905	4.4.5.(4)
	3,4TNV84(T)	83.945~83.975	83.900	
	3,4TNV88	87.945~87.975	87.900	
	4TNV94L	93.945~93.955	93.900	
	4TNV98(T)	97.940~97.950	97.895	
	4TNV106(T)	105.930~105.960	105.880	
Piston diameter measure position (Upward from the bottom end of the piston)	3TNV82A	16	-	
	3,4TNV84(T)	24	-	
	3,4TNV88	24	-	
	4TNV94L	22	-	
	4TNV98(T)	22	-	
	4TNV106(T)	30	-	
Piston pin	3TNV82A	Hole inside diameter	23.000~23.009	23.039
		Pin outside diameter	22.995~23.000	22.965
		Clearance	0.000~0.014	0.074
	TNV84~88	Hole inside diameter	26.000~26.009	26.039
		Pin outside diameter	25.995~26.000	25.965
		Clearance	0.000~0.014	0.074
	4TNV94L·98	Hole inside diameter	30.000~30.009	30.039
		Pin outside diameter	29.989~30.000	29.959
		Clearance	0.000~0.020	0.080
	4TNV106(T)	Hole inside diameter	37.000~37.011	37.039
		Pin outside diameter	36.989~37.000	36.959
		Clearance	0.000~0.022	0.080

mm

## Piston ring

				mm	
Model	Inspection item		Standard	limit	Reference page
3TNV82A TNV84	Top ring	Ring groove width	2.065~2.080	-	4.4.5.(4)
		Ring width	1.970~1.990	1.950	
		Side clearance	0.075~0.110	-	
		End clearance	0.200~0.400	0.490	
	Second ring	Ring groove width	2.035~2.050	2.150	
		Ring width	1.970~1.990	1.950	
		Side clearance	0.045~0.080	0.200	
		End clearance	0.200~0.400	0.490	
	Oil ring	Ring groove width	4.015~4.030	4.130	
		Ring width	3.970~3.990	3.950	
		Side clearance	0.025~0.060	0.180	
		End clearance	0.200~0.400	0.490	
TNV88	Top ring	Ring groove width	2.060~2.075	-	
		Ring width	1.970~1.990	1.950	
		Side clearance	0.070~0.105	-	
		End clearance	0.200~0.400	0.490	
	Second ring	Ring groove width	2.025~2.040	2.140	
		Ring width	1.970~1.990	1.950	
		Side clearance	0.035~0.070	0.190	
		End clearance	0.200~0.400	0.490	
	Oil ring	Ring groove width	4.015~4.030	4.130	
		Ring width	3.970~3.990	3.950	
		Side clearance	0.025~0.060	0.180	
		End clearance	0.200~0.400	0.490	
4TNV94L/98	Top ring	Ring groove width	2.040~2.060	-	
		Ring width	1.940~1.960	1.920	
		Side clearance	0.080~0.120	-	
		End clearance	0.250~0.450	0.540	
	Second ring	Ring groove width	2.080~2.095	2.195	
		Ring width	1.970~1.990	1.950	
		Side clearance	0.090~0.125	0.245	
		End clearance	0.450~0.650	0.730	
	Oil ring	Ring groove width	3.015~3.030	3.130	
		Ring width	2.970~2.990	2.950	
		Side clearance	0.025~0.060	0.180	
		End clearance	0.250~0.450	0.550	
4TNV106(T)	Top ring	Ring groove width	2.520~2.540	-	
		Ring width	2.440~2.460	2.420	
		Side clearance	0.060~0.100	-	
		End clearance	0.300~0.450	0.540	
	Second ring	Ring groove width	2.070~2.085	2.185	
		Ring width	1.970~1.990	1.950	
		Side clearance	0.080~0.115	0.235	
		End clearance	0.450~0.600	0.680	
	Oil ring	Ring groove width	3.015~3.030	3.130	
		Ring width	2.970~2.990	2.950	
		Side clearance	0.025~0.060	0.180	
		End clearance	0.300~0.500	0.600	

## (5) Connecting rod

mm			
Inspection item	Standard	Limit	Reference page
Thrust clearance	0.2~0.4	-	4.4.4

## Rod small end

mm				
Model	Item	Standard	Limit	Reference page
3TNV82A	Bushing inside diameter	23.025~23.038	23.068	4.4.5.(5)
	Pin outside diameter	22.995~23.000	22.967	
	Clearance	0.025~0.043	0.101	
TNV84-88	Bushing inside diameter	26.025~26.038	26.068	
	Pin outside diameter	25.995~26.000	25.967	
	Clearance	0.025~0.043	0.101	
4TNV94L/98	Bushing inside diameter	30.025~30.038	30.068	
	Pin outside diameter	29.987~30.000	29.959	
	Clearance	0.025~0.051	0.109	
4TNV106(T)	Bushing inside diameter	37.025~37.038	37.068	
	Pin outside diameter	36.989~37.000	36.961	
	Clearance	0.025~0.049	0.107	

## (6) Tappet

mm				
Inspection item		Standard	Limit	Reference page
TNV82A-88	Tappet hole (block) inside diameter	12.000~12.025	12.045	4.4.5.(6)
	Tappet stem outside diameter	11.975~11.990	11.955	
	Clearance	0.010~0.050	0.090	
4TNV94L 98	Tappet hole (block) inside diameter	12.000~12.018	12.038	
	Tappet stem outside diameter	11.975~11.990	11.955	
	Clearance	0.010~0.043	0.083	
4TNV106(T)	Tappet hole (block) inside diameter	14.000~14.018	14.038	
	Tappet stem outside diameter	13.966~13.984	13.946	
	Clearance	0.015~0.052	0.092	

## 12.3 Lubricating Oil System (Trochoid Pump)

### (1) Outside clearance of outer rotor

mm			
Model	Standard	Limit	Reference page
3TNV82A~88	0.12~0.21	0.30	5.5.1(1)
4TNV94L/98	0.100~0.155	0.25	
4TNV106(T)	0.100~0.165	0.25	

### (2) Side clearance of outer rotor

mm			
Model	Standard	Limit	Reference page
3TNV82A~88	0.02~0.07	0.12	5.5.1(1)
4TNV94L/98	0.05~0.10	0.15	
4TNV106(T)	0.03~0.12	0.17	

### (3) Inside clearance of inner rotor

mm					
Item	Parts	Standard	Standard	Limit	Reference page
Inside clearance of inner rotor	Gear boss diameter	53.05~53.15	0.3~0.5	0.6	5.5.1 (2)
	Rotor diameter	53.45~53.55			
Width across flat clearance of inner rotor	Width across flat of Gear boss	49.45~49.75	0.2~0.6	0.7	
	Width across flat of rotor	49.95~50.05			

### (4) Rotor shaft clearance

mm				
Model	Inspection item	Standard	Limit	Reference page
4TNV94L/ 98	Gear case bearing I.D.	12.980~13.02	13.05	5.5.1(3)
	Rotor shaft O.D.	12.955~12.975	12.945	
	Rotor clearance	0.035~0.065	0.105	
4TNV106(T)	Gear case bearing I.D.	13.00~13.02	13.05	
	Rotor shaft O.D.	12.955~12.965	12.945	
	Rotor clearance	0.035~0.065	0.105	

# 13. TIGHTENING TORQUE for BOLTS and NUTS

## 13.1 Tightening Torques for Main Bolts and Nuts

Part and engine model		Thread diameter xpitch mm	Tightening torque Nm(kgf·m)	Lubricating oil application (thread portion, and seat surface)	Reference page
Cylinder head bolt	3TNV82A	M9x1.25	61.7~65.7 (6.3~6.7)	Applied	4.2.4
	TNV84~88	M10x1.25	85.3~91.1 (8.7~9.3)		
	4TNV94L·98	M11x1.25	103.1~112.9 (10.5~11.5)		
	4TNV106(T)	M13x1.5	188.0~197.8 (19.0~20.0)		
Connecting rod bolt	3TNV82A	M8x1.0	37.2~41.2 (3.8~4.2)	Applied	4.4.4
	TNV84~88	M9x1.0	44.1~49.0 (4.5~5.0)		
	4TNV94L·98	M10x1.0	53.9~58.8 (5.5~6.0)		
	4TNV106(T)	M11x1.0	78.5~83.4 (8.0~8.5)		
Flywheel set bolt	TNV82A~88	M10x1.25	83.3~88.2 (8.5~9.0)	Applied	4.3.4
	4TNV94L·98·106(T)	M14x1.5	186.2~205.8 (19~21)		
Bearing cap set bolt	3TNV82A	M10x1.25	76.4~80.4 (7.8~8.2)	Applied	4.4.4
	TNV84~88	M12x1.5	93.2~98.1 (9.5~10.5)		
	4TNV94L·98	M11x1.25	108.1~117.9 (11.0~12.0)		
	4TNV106(T)	M14x1.5	186.2~205.8 (19~21)		
Crankshaft pulley set bolt	TNV82A~88	M14x1.5	112.7~122.7 (11.5~12.5)	Applied	4.3.4
	4TNV94L·98·106(T)	M14x1.5	107.9~127.5 (11.0~13.0)		
Fuel nozzle set bolt	TNV82A~88	M8x1.25	24.4~28.4 (2.5~2.9)	Not applied	-
	4TNV94L·98·106(T)	M8x1.25	22.6~28.4 (2.3~2.9)		
Fuel pump drive gear set nut	TNV82A~88	M14x1.5	78~88(8~9)	Not applied	4.3.4
	4TNV94L·98·106(T)	M18x1.5	113~123 (11.5~12.5)		
Fuel injection pipe set bolt	TNV82A~88	M12x1.5	29.4~34.3 (3.0~3.5)	Not applied	-
	4TNV94L·98·106(T)	M12x1.5	19.6~24.5 (2.0~2.5)		
Fuel return pipe joint bolt	4TNV94L·98·106(T)	M6x1.0	7.8~9.8 (0.8~1.0)	Not applied	-
Rocker arm cover set bolt	4TNV106(T)	M8x1.25	16.7~22.5 (1.7~2.3)	Not applied	-
EPA flange set bolt	4TNV106(T)	M18x1.5	113~123 (11.5~12.5)	Not applied	-

## 13.2 Tightening Torques for Standard Bolts and Nuts

Item	Nominal thread diameter xpitch	Tightening torque Nm(kgf-m)	Remarks
Hexagon bolt (7T) and nut	M6x1	9.8~11.8 (1.0~1.2)	Use 80% of the value at left when the tightening part is aluminum. Use 60% of the value at left for 4T bolts and lock nuts.
	M8x1.25	22.6~28.4 (2.3~2.9)	
	M10x1.5	44.1~53.9 (4.5~5.5)	
	M12x1.75	78.4~98.0 (8.0~10)	
	M14x1.5	127.5~147.1 (13~15)	
	M16x1.5	215.7~235.4 (22~24)	
PT plug	1/8	9.8 (1.0)	-
	1/4	19.6 (2.0)	
	3/8	29.4 (3.0)	
	1/2	58.8 (6.0)	
Pipe joint bolt	M8	12.7~16.7 (1.3~1.7)	-
	M10	19.6~25.4 (2.0~2.6)	
	M12	24.5~34.3 (2.5~3.5)	
	M14	39.2~49.0 (4.0~5.0)	
	M16	49.0~58.8 (5.0~6.0)	

Note) Lubricating oil is not applied to threaded portion and seat surface.





# **YANMAR CO.,LTD.**

## **HEAD OFFICE**

1-32, CHAYAMACHI, KITA-KU, OSAKA 530-8311, JAPAN

## **YANMAR DIESEL AMERICA CORP.**

951 CORPORATE GROVE DRIVE, BUFFALO GROVE, IL 60089-4508, U.S.A.

TEL : 1-847-541-1900

FAX : 1-847-541-2161

## **YANMAR EUROPE B.V.**

P.O. BOX 30112, 1303 AC ALMERE NL

BRUGPLEIN 11, 1332 BS ALMERE-DE VAART, THE NETHERLANDS

TEL : 31-36-5493200

FAX : 31-36-5493209

## **YANMAR ASIA (SINGAPORE) CORPORATION PTE LTD.**

4 TUAS LANE. SINGAPORE 638613

TEL : 65-6861-3855

FAX : 65-6862-5195