

# GROUP 5 COMBINED OPERATION

## 1. OUTLINE

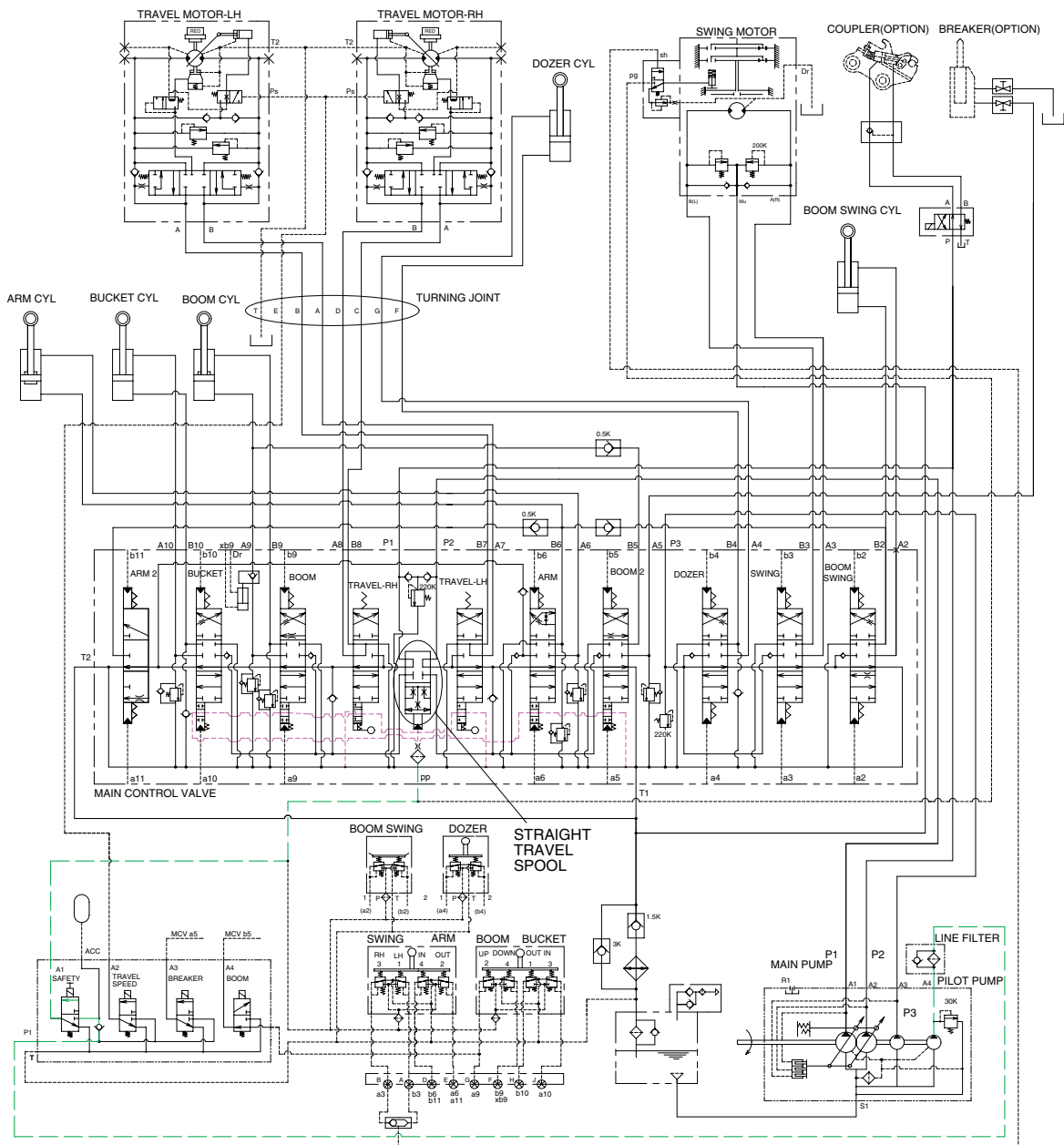

R5573HC30

The oil from the P1, P2, P3 pump flows through the neutral oil passage, bypass oil passage and confluence oil passage in the main control valve. Then the oil goes to each actuator and operates them. Check valves and orifices are located on these oil passage in the main control valve. These control the oil from the main pumps so as to correspond to the operation of each actuator and smooth the combined operation.

### STRAIGHT TRAVEL SPOOL

This straight travel spool for straight travel is provided in the main control valve.

If any actuator is operated when traveling, the straight travel spool is pushed to the up by the pilot oil pressure.

Consequently, the left and right travel oil supply passage are connected, and equivalent amount of oil flows into the left and right travel motors. This keeps the straight travel.

## 2. COMBINED SWING AND BOOM OPERATION

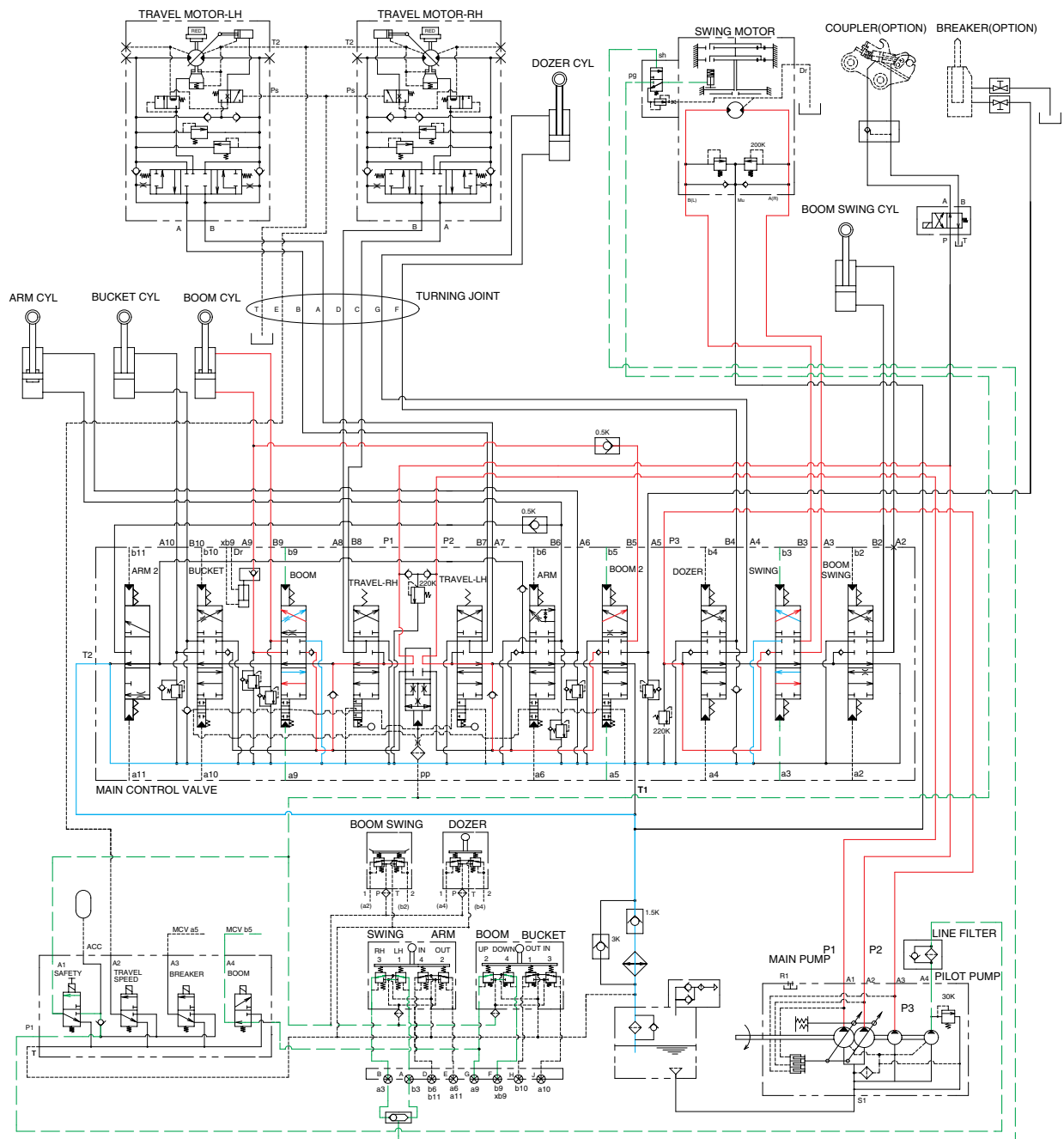

R5573HC31

When the swing and boom functions are operated, simultaneously the swing spool and boom spools in the main control valve are moved to the functional position by the pilot oil pressure from the remote control valve.

The oil from the P1 and P2 pump flows into the boom cylinder through boom and boom 2 spool.

The oil from the P3 pump flows into the swing motor through the swing spool.

The superstructure swings and the boom is operated.

### 3. COMBINED SWING AND ARM OPERATION

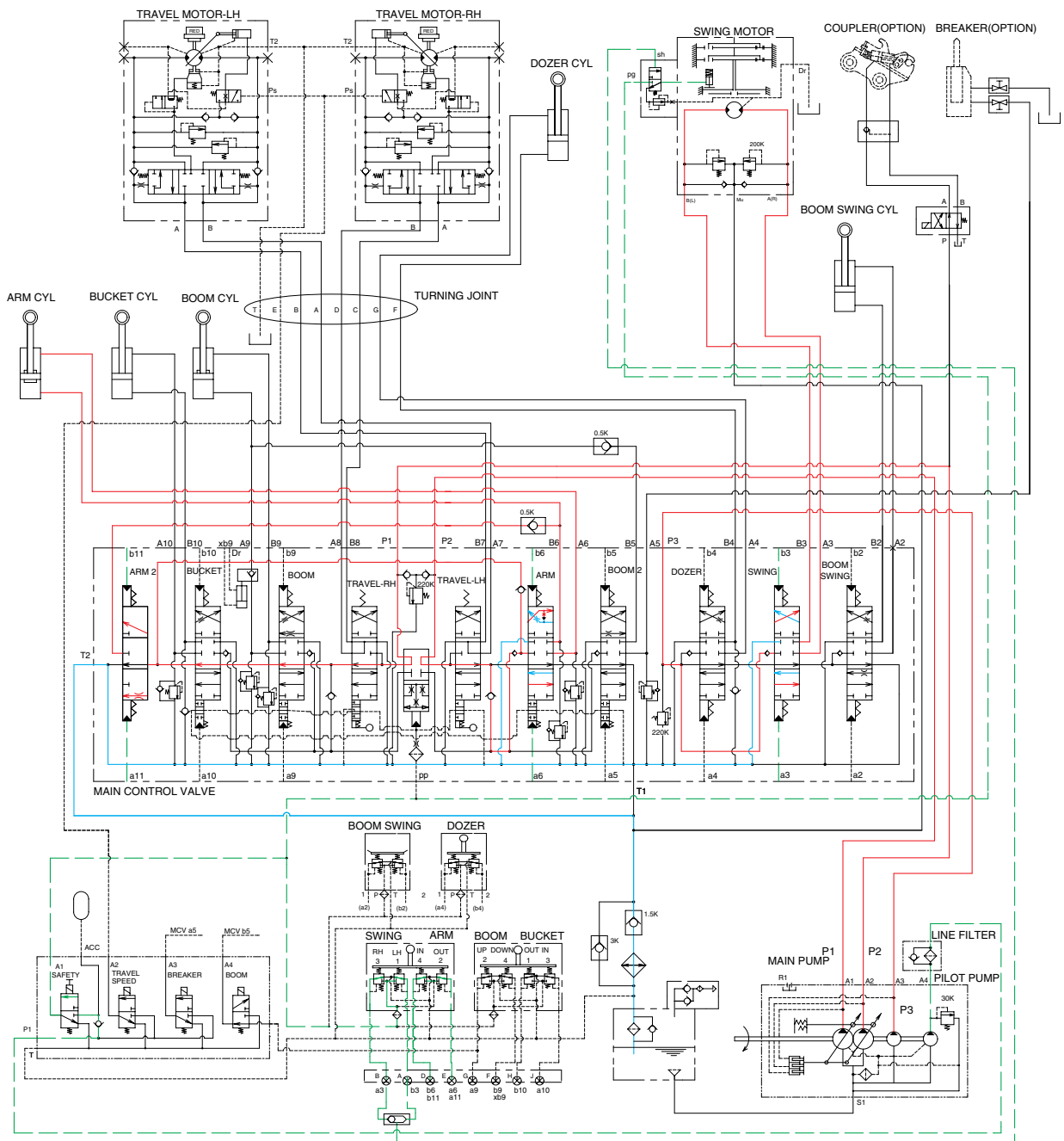

R5573HC32

When the swing and arm functions are operated, simultaneously the swing spool and arm spools in the main control valve are moved to the functional position by the pilot oil pressure from the remote control valve.

The oil from the P3 pump flows into the swing motor through swing spool.

The oil from the P1 and P2 pump flows into the arm cylinder through the arm and arm 2 spool.

The superstructure swings and the arm is operated.



## 5. COMBINED SWING, BOOM, ARM AND BUCKET OPERATION

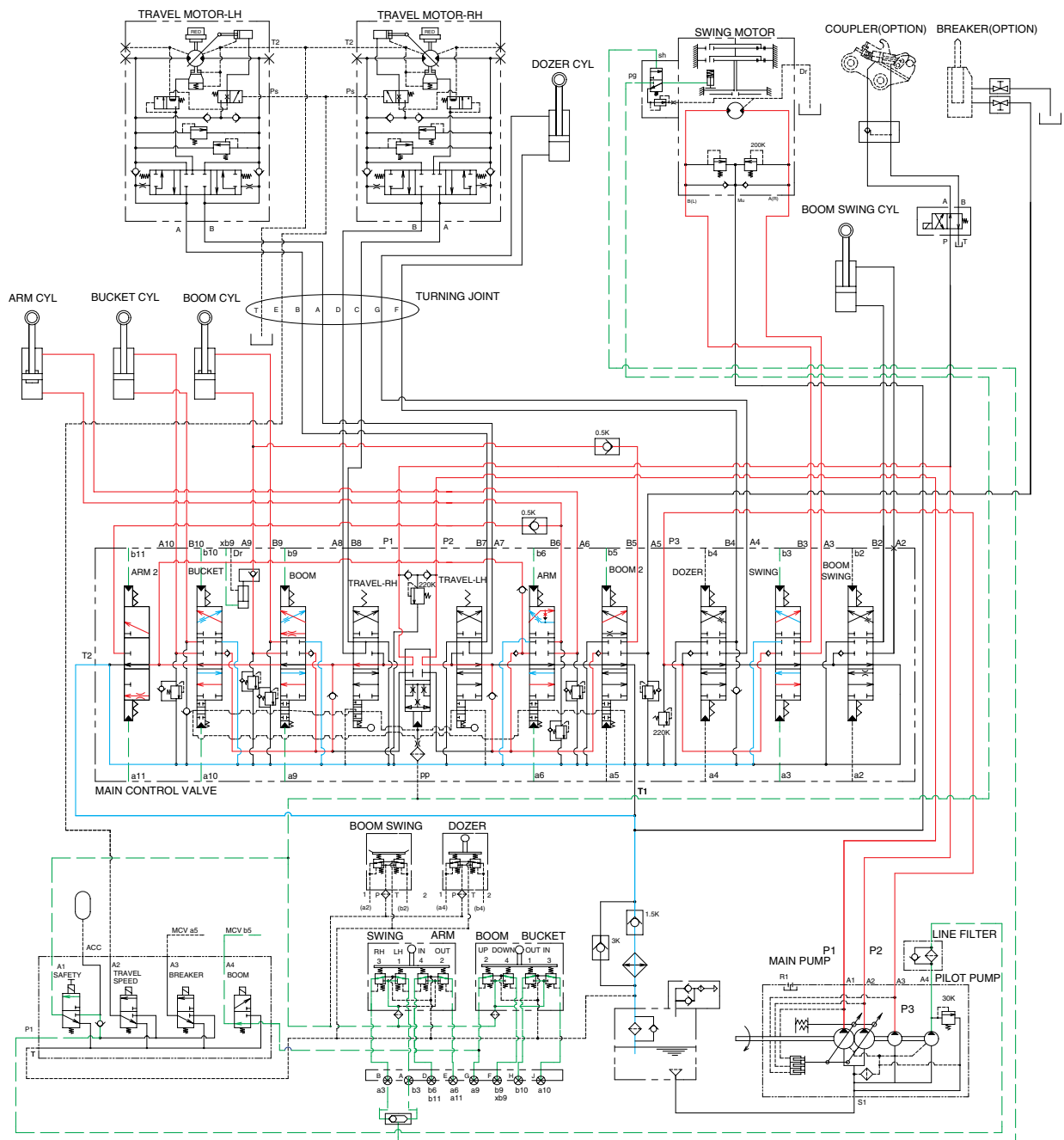

R5573HC34

When the swing, boom, arm and bucket functions are operated, simultaneously each spool in the main control valve is moved to the functional position by the pilot oil pressure from the remote control valve.

The oil from the P1 pump flows into the boom cylinders and arm cylinder through boom 2 spool, arm spool.

The oil from the P2 pump flows into the boom cylinders, arm cylinder and bucket cylinder through the boom spool, arm 2 spool, bucket spool.

The oil from the P3 pump flows into the swing motor through the swing spool.

The superstructure swings and the boom, arm and bucket are operated.

## 6. COMBINED SWING AND TRAVEL OPERATION

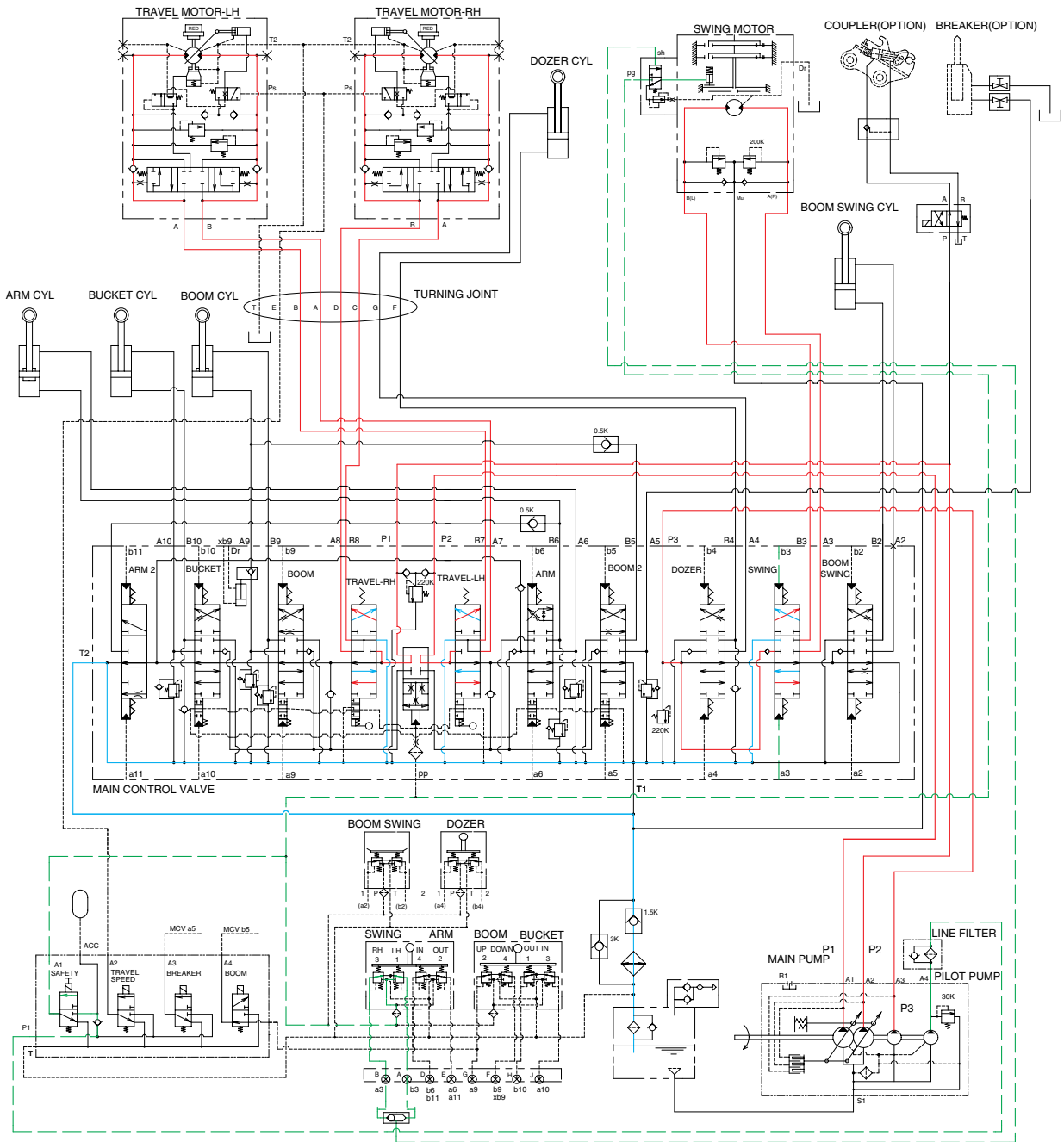

R5573HC35

When the swing and travel functions are operated, simultaneously the swing spool and travel spools in the main control valve are moved to the functional position by the pilot oil pressure from the remote control valve and the travel levers.

The oil from the MCV P3 pump flows into the swing motor through the swing spool.

The oil from the P1 pump flows into the travel motor through the LH travel spool.

The oil from the P2 pump flows into the travel motor through RH travel spool.

The superstructure swings and the machine travels straight.

## 7. COMBINED BOOM AND TRAVEL OPERATION

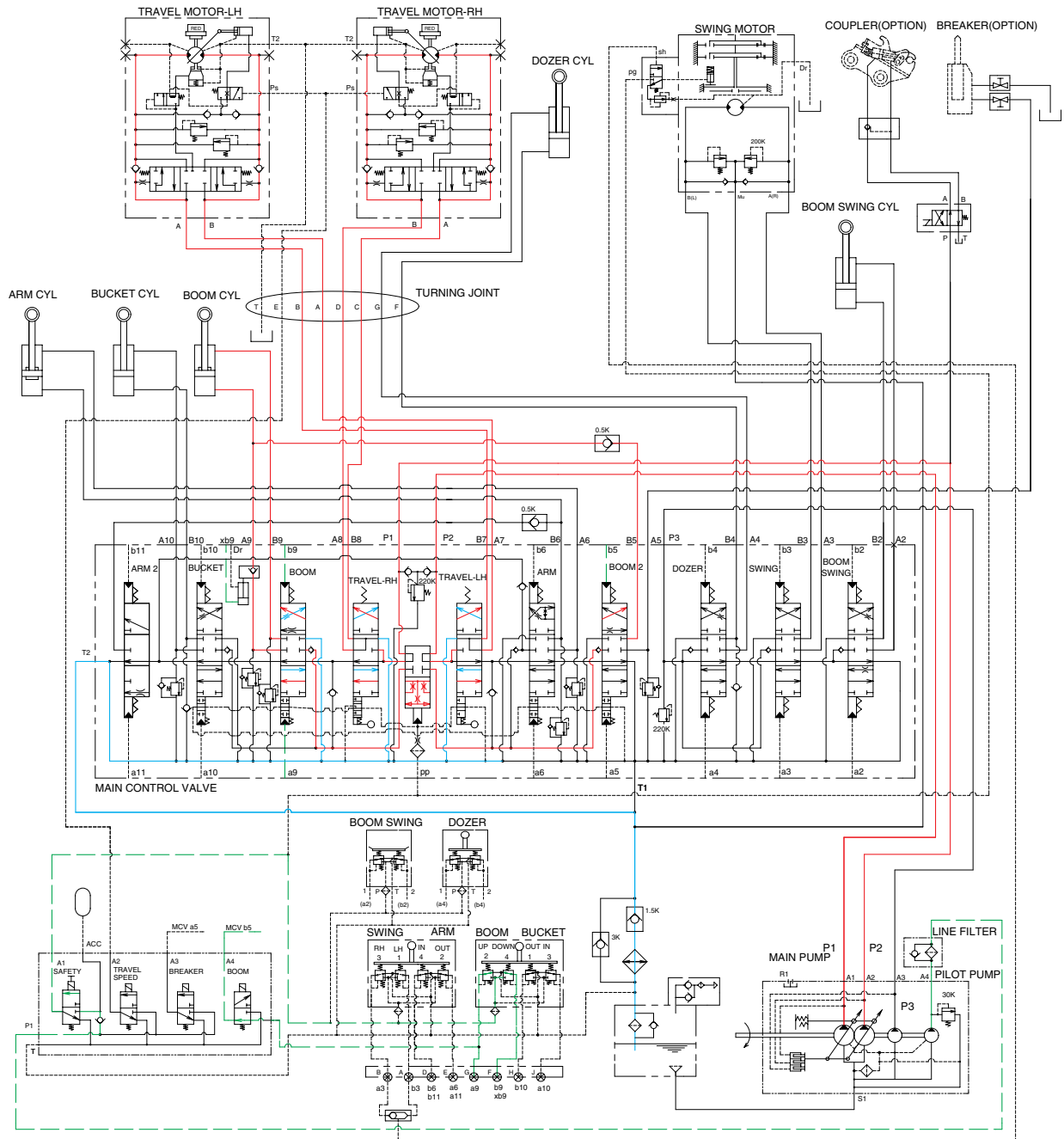

R5573HC36

When the boom and travel functions are operated, simultaneously the boom spools and travel spools in the main control valve are moved to the functional position by the pilot oil pressure from the remote control valve and the straight travel spool is pushed to the up by the oil pressure from pilot pump. The oil from the P1 and P2 pumps flows into the boom cylinders and the travel motors through boom, boom 2, travel LH and travel RH spools via the straight travel spool. The boom is operated and the machine travels straight.

## 8. COMBINED ARM AND TRAVEL OPERATION

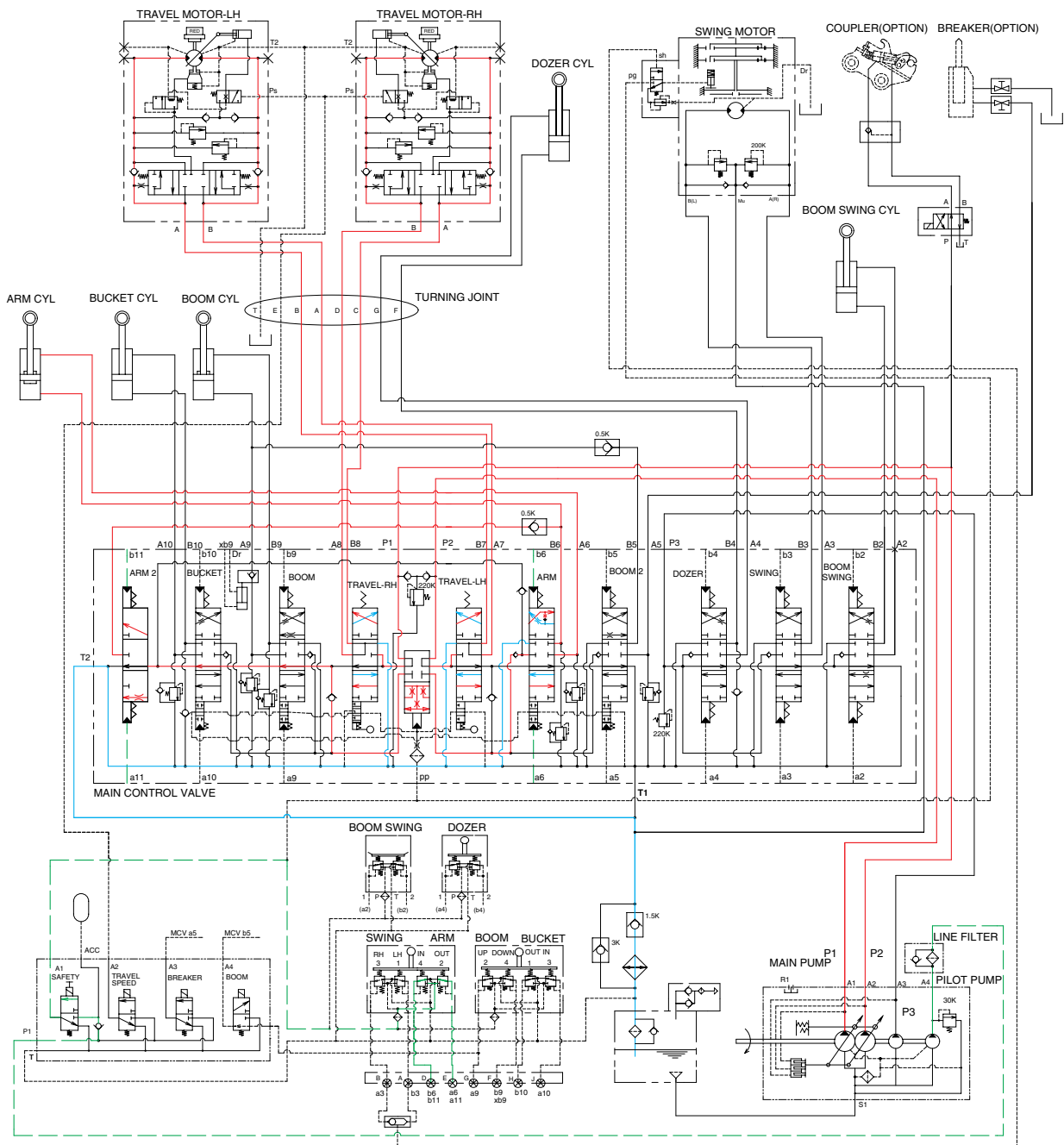

R5573HC37

When the arm and travel functions are operated, simultaneously the arm spools and travel spools in the main control valve are moved to the functional position by the pilot oil pressure from the remote control valve and the straight travel spool is pushed to the up by the oil pressure from pilot pump. The oil from the P1 and P2 pumps flows into the travel motors and the arm cylinder through travel spools and arm spools via the straight travel spool. The arm is operated and the machine travels straight.



## 9. COMBINED BUCKET AND TRAVEL OPERATION

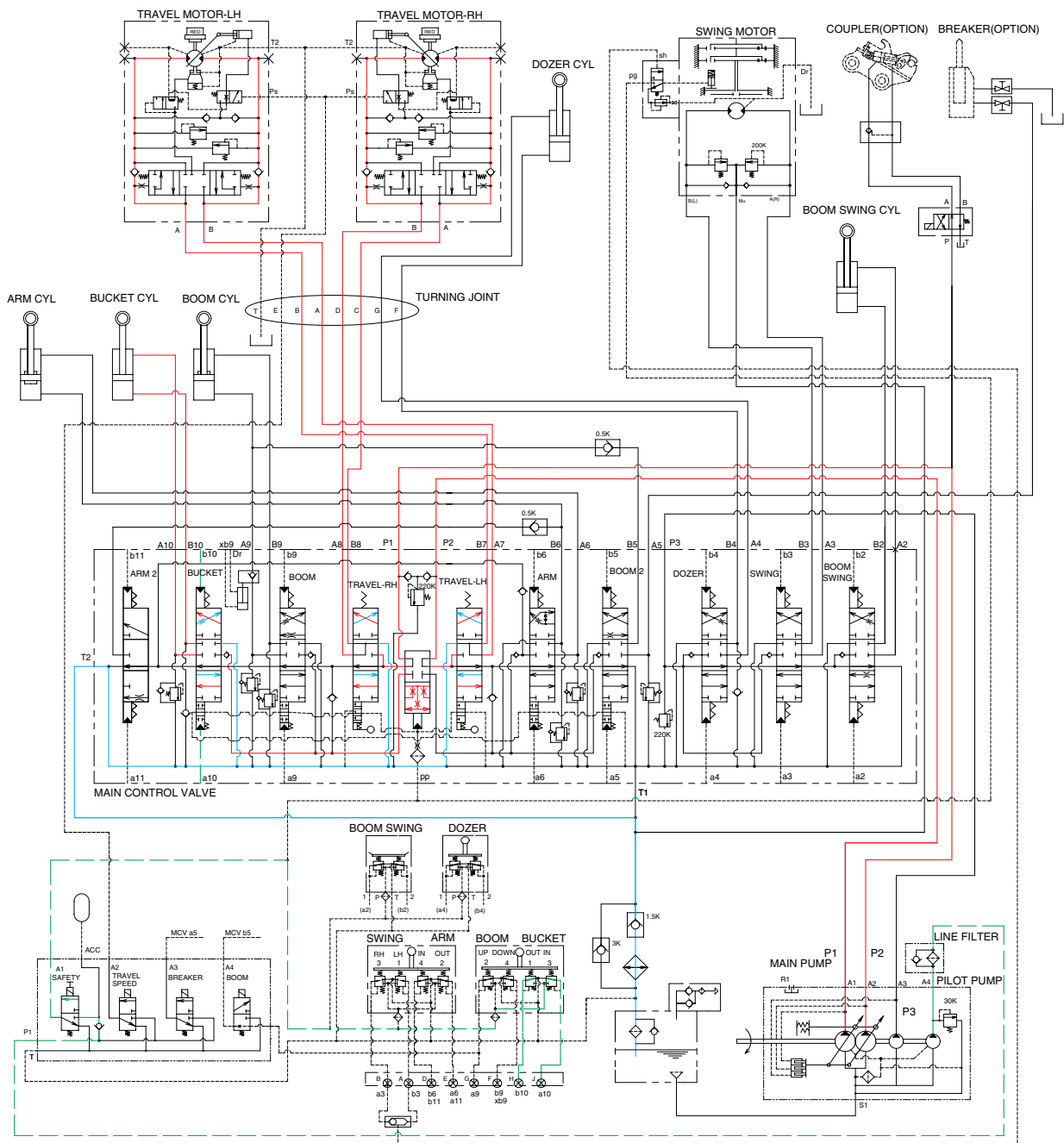

R5573HC38

When the bucket and travel functions are operated, simultaneously the bucket spool and travel spools in the main control valve are moved to the functional position by the pilot oil pressure from the remote control valve, and the straight travel spool is pushed to the up by the oil pressure from pilot pump. The oil from the P1 and P2 pumps flows into the travel motors and the bucket cylinder through the travel spools and the bucket spool via the straight travel spool. The bucket is operated and the machine travels straight.