

SECTION 9 COMPONENT MOUNTING TORQUE

Group 1 Introduction Guide	9-1
Group 2 Engine System	9-2
Group 3 Electric System	9-4
Group 4 Hydraulic System	9-6
Group 5 Undercarriage	9-9
Group 6 Structure	9-10
Group 7 Work Equipment	9-14

SECTION 9 COMPONENT MOUNTING TORQUE

GROUP 1 INTRODUCTION GUIDE

1. This section shows bolt specifications and standard torque values needed when mounting components to the machine.
 2. Use genuine Hyundai spare parts.
We expressly point out that Hyundai will not accept any responsibility for defects resulted from non-genuine parts.
In such cases Hyundai cannot assume liability for any damage.
- ※ **Only metric fasteners can be used and incorrect fasteners may result in machine damage or malfunction.**
 - ※ **Before installation, clean all the components with a non-corrosive cleaner. Bolts and threads must not be worn or damaged.**

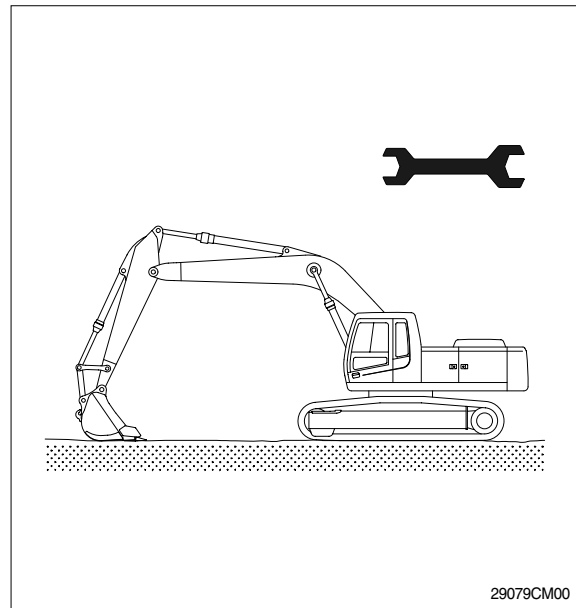

GROUP 2 ENGINE SYSTEM

ENGINE AND ACCESSORIES MOUNTING

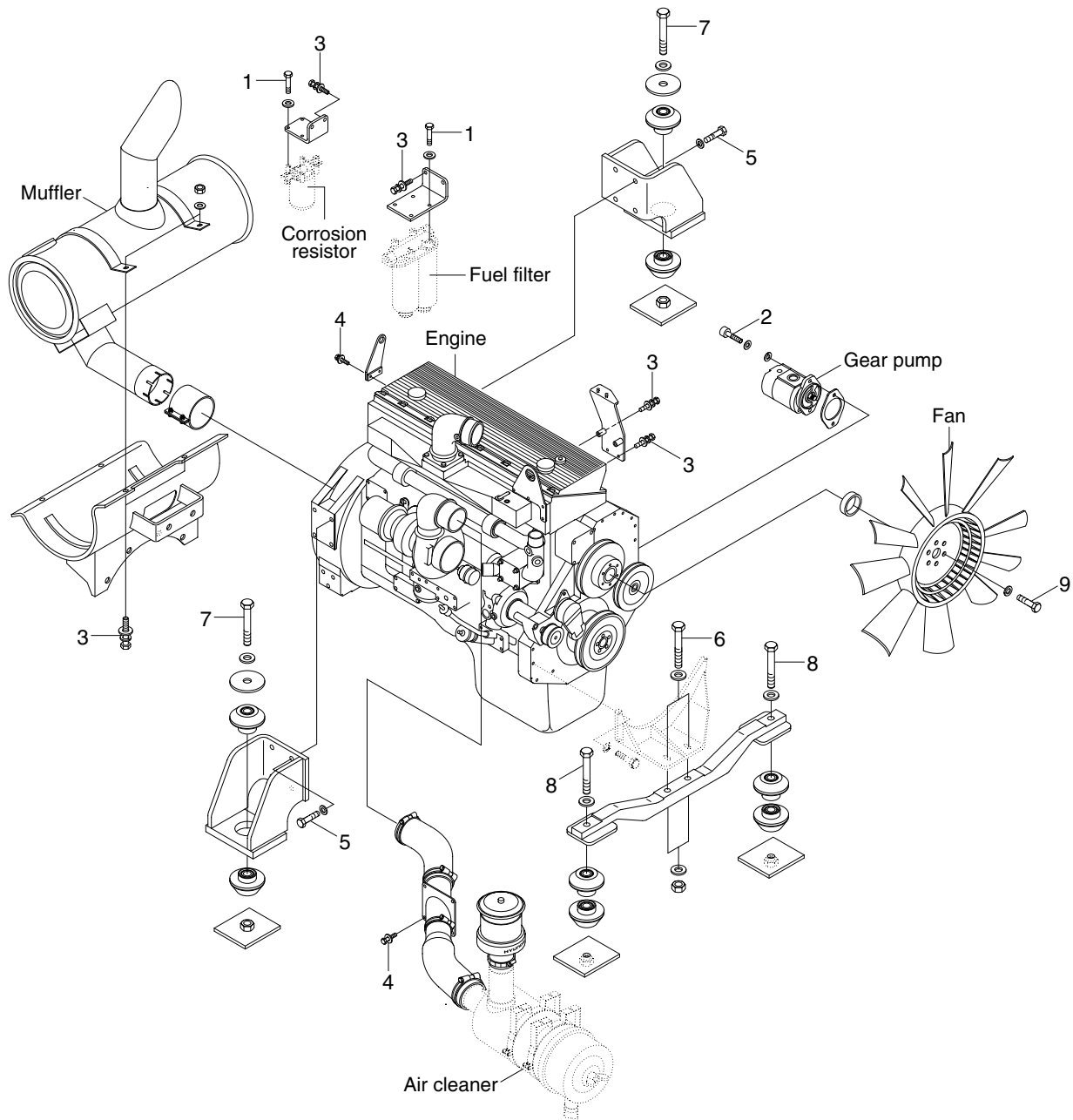

51079CM01

· Tightening torque

Item	Size	kgf · m	lbf · ft
1	M 6×1.0	1.44±0.3	10.4±2.2
2	M 8×1.25	4.05±0.8	29.3±5.8
3	M10×1.5	6.9±1.4	49.9±10.1
4	M12×1.75	12.8±3.0	92.6±21.7
5	M16×2.0	29.7±5.0	215±36.2

Item	Size	kgf · m	lbf · ft
6	M20×2.5	57.9±8.7	419±62.9
7	M22×2.5	69.8±6.0	505±43.3
8	M22×2.5	81.9±16.1	592±116
9	3/8-16 UNC	6.1±1.0	44.1±7.2
-	-	-	-

COOLING SYSTEM AND FUEL TANK MOUNTING

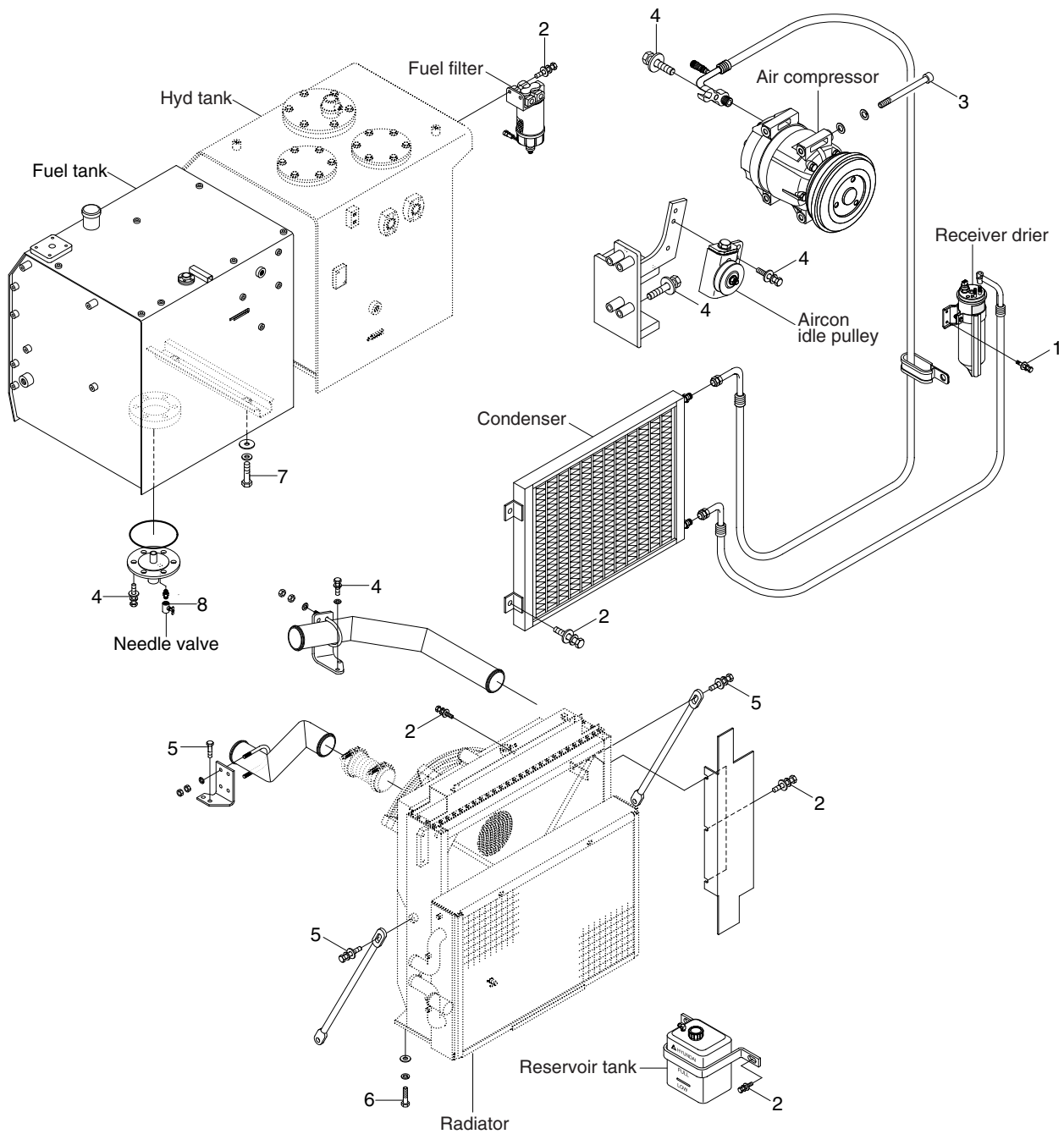

51079CM02

· Tightening torque

Item	Size	kgf · m	lbf · ft
1	M 6×1.0	1.05±0.2	7.6±1.45
2	M 8×1.25	2.5±0.5	18.1±3.6
3	M 8×1.25	4.05±0.8	29.3±5.8
4	M10×1.5	6.9±1.4	49.9±10.1

Item	Size	kgf · m	lbf · ft
5	M12×1.75	12.8±3.0	92.6±21.7
6	M16×2.0	29.7±4.5	215±32.5
7	M20×2.5	45±5.1	325±36.9
8	-	2.3±0.6	16.6±4.3

GROUP 3 ELECTRIC SYSTEM

ELECTRIC COMPONENTS MOUNTING 1

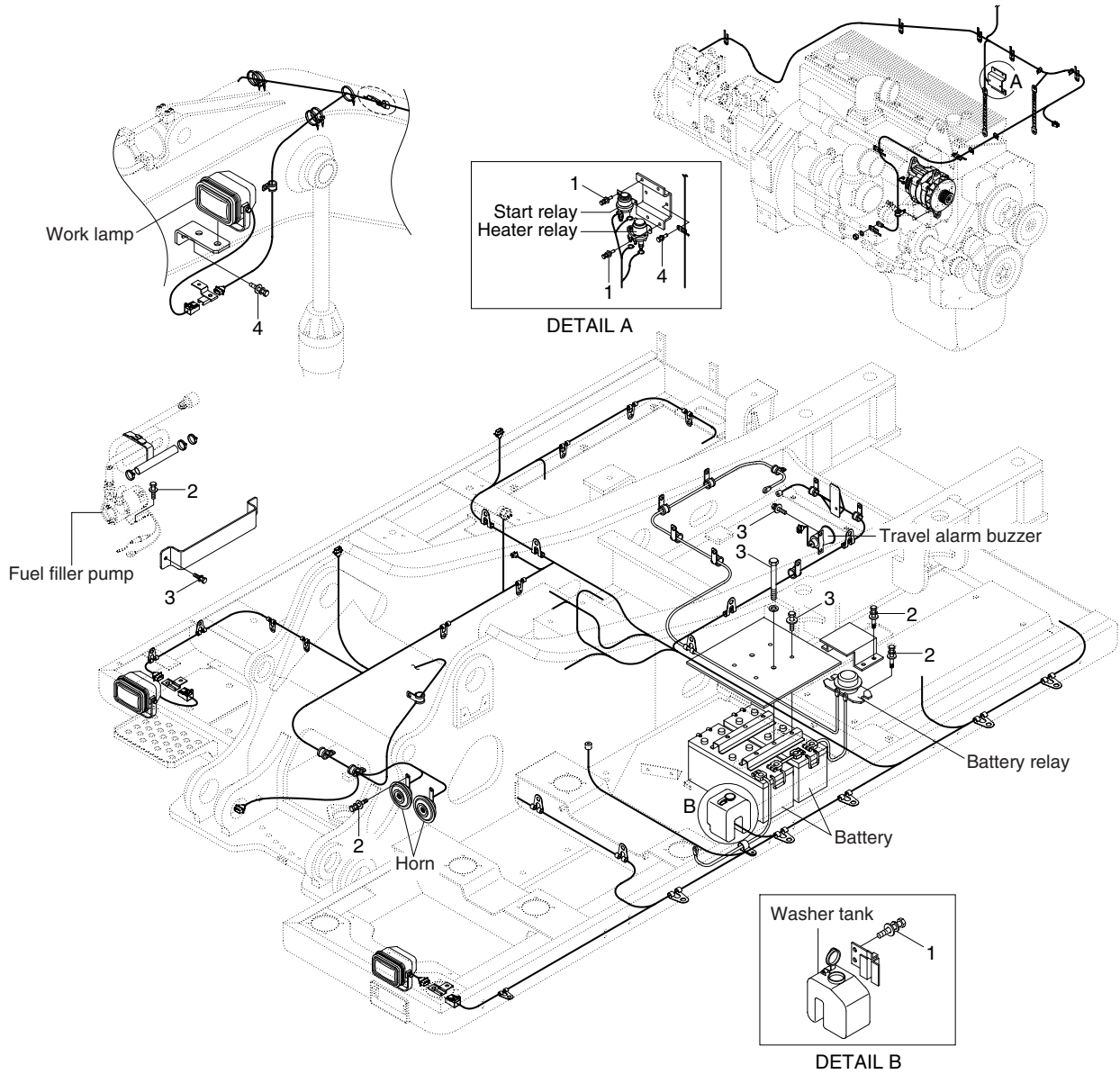

51079CM03

· Tightening torque

Item	Size	kgf · m	lbf · ft
1	M 6×1.0	1.05±0.2	7.6±1.45
2	M 8×1.25	2.5±0.5	18.1±3.6

Item	Size	kgf · m	lbf · ft
3	M10×1.5	6.9±1.4	49.9±10.1
4	M12×1.75	12.8±3.0	92.6±21.7

ELECTRIC COMPONENTS MOUNTING 2

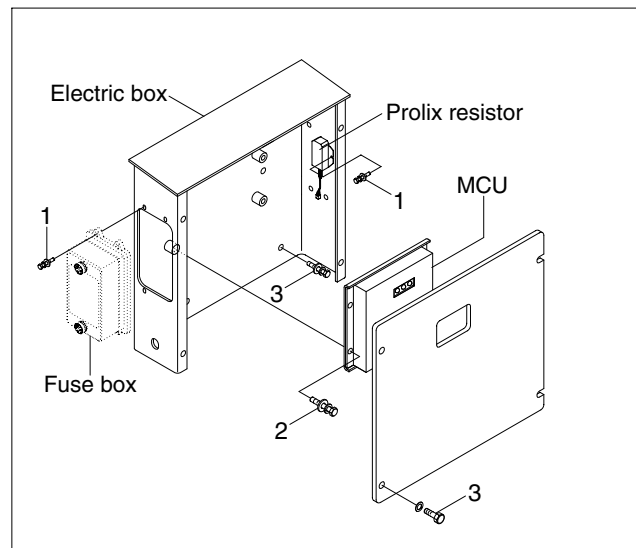
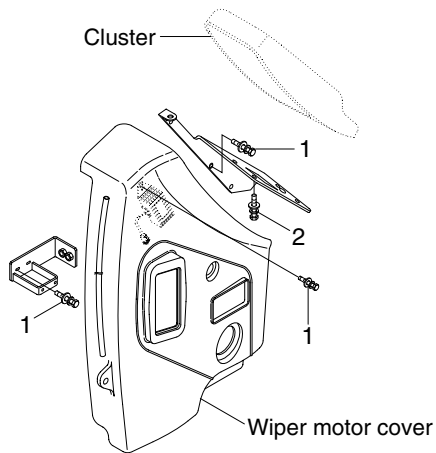
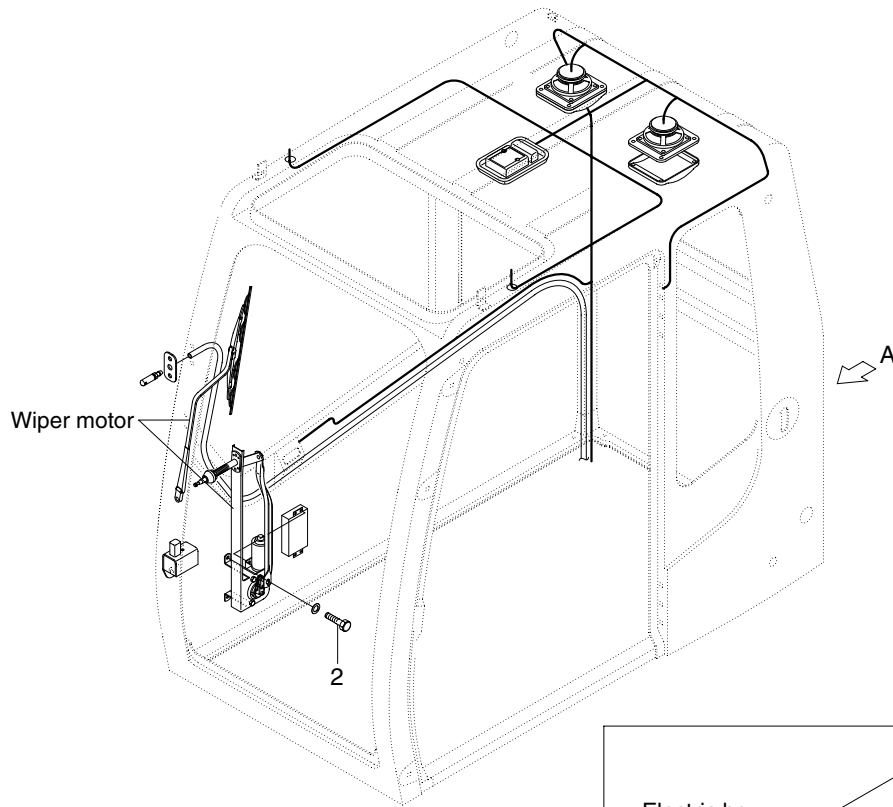

VIEW A

51079CM04

· Tightening torque

Item	Size	kgf · m	lbf · ft
1	M 6×1.0	1.05±0.2	7.6±1.45
2	M 8×1.25	2.5±0.5	18.1±3.6

Item	Size	kgf · m	lbf · ft
3	M10×1.5	6.9±1.4	49.9±10.1
-	-	-	-

GROUP 4 HYDRAULIC SYSTEM

HYDRAULIC COMPONENTS MOUNTING 1

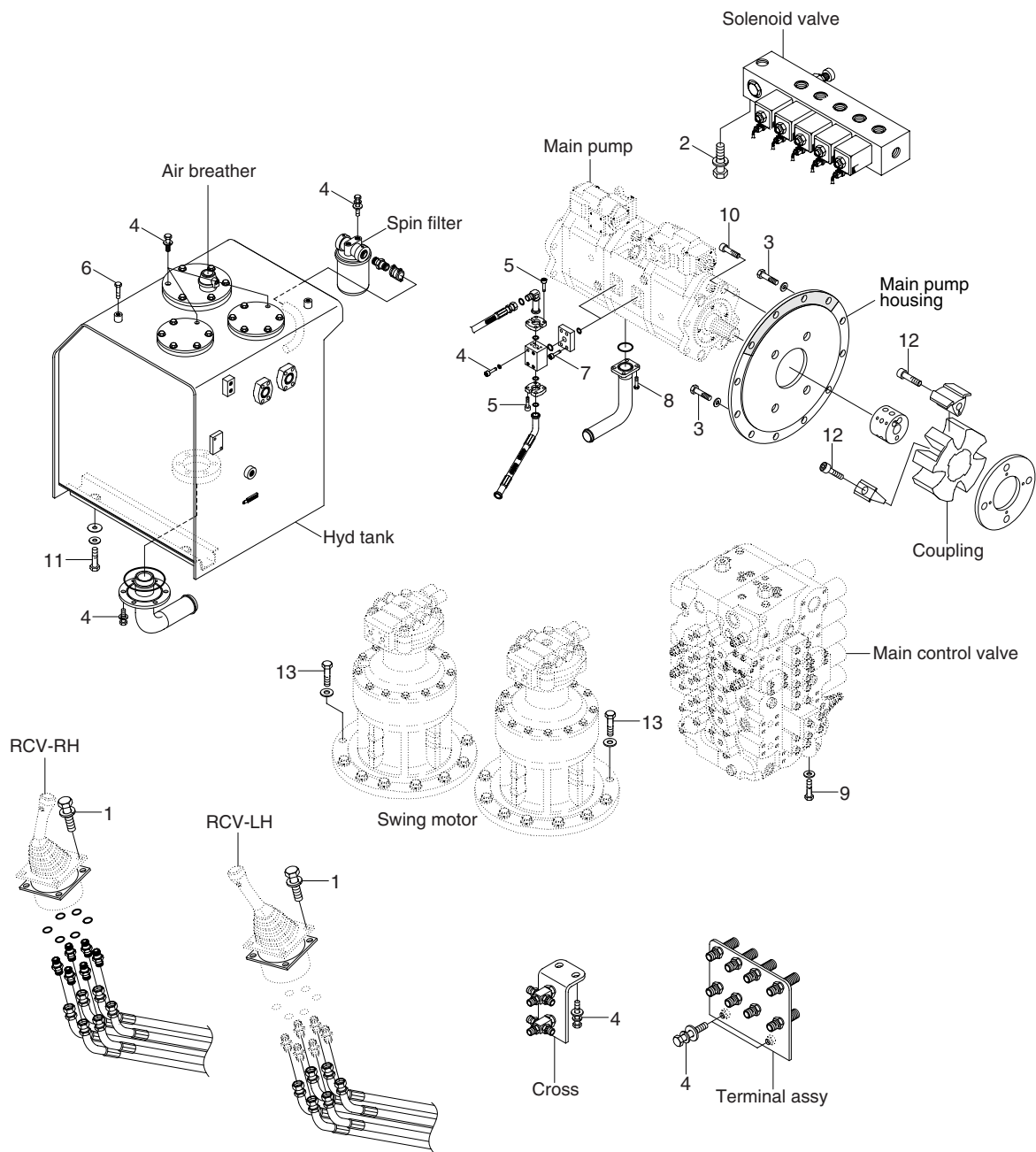

51079CM05

· Tightening torque

Item	Size	kgf · m	lbf · ft
1	M 6×1.0	1.05±0.2	7.6±1.45
2	M 8×1.25	2.5±0.5	18.1±3.6
3	M10×1.5	4.8±0.3	34.7±2.2
4	M10×1.5	6.9±1.4	49.9±10.1
5	M10×1.5	8.27±1.7	59.8±12.3
6	M12×1.75	12.8±3.0	92.6±21.7
7	M12×1.75	14.7±2.2	106±15.9

Item	Size	kgf · m	lbf · ft
8	M16×2.0	35.6±7.1	257±51.3
9	M20×2.5	42±4.5	304±30.5
10	M20×2.5	44±6.6	318±47.7
11	M20×2.5	45±5.1	325±36.8
12	M20×2.5	46.5±2.5	336±18.1
13	M20×2.5	58.4±6.4	422±46.3
-	-	-	-

HYDRAULIC COMPONENTS MOUNTING 2

Double acting attachment piping

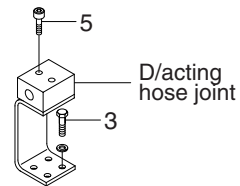
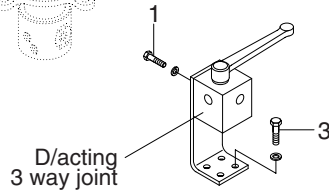
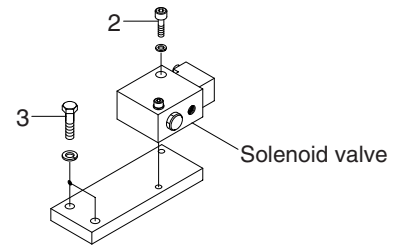
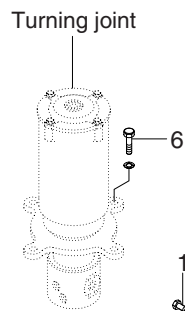
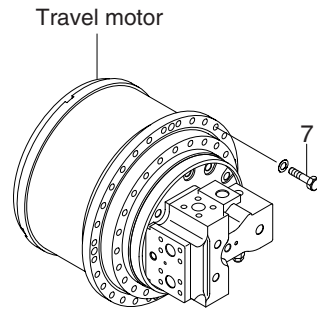
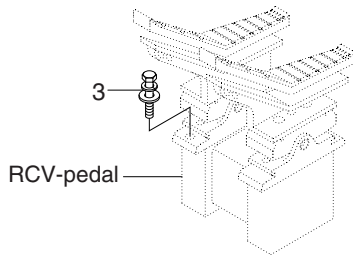
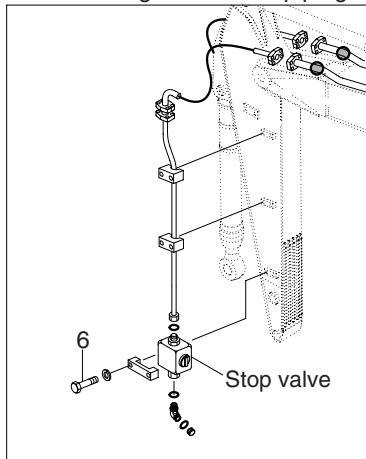

Boom safety lock system

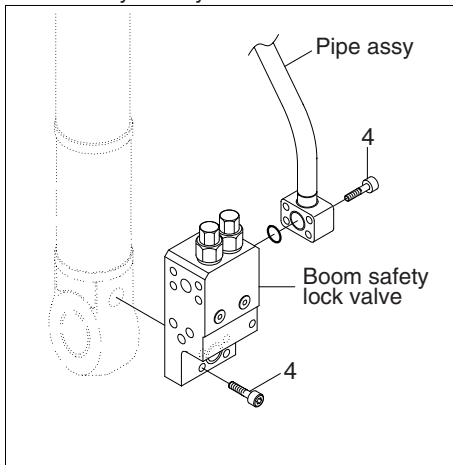

Arm safety lock system

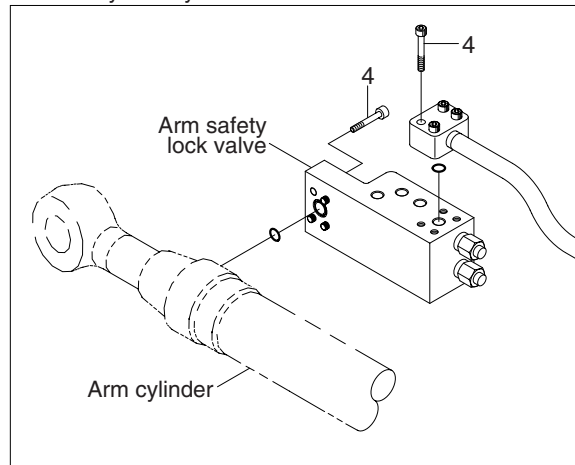

51079CM06

• Tightening torque

Item	Size	kgf · m	lbf · ft
1	M 8×1.25	3.43±0.7	24.8±5.1
2	M 8×1.25	4.05±0.8	29.3±5.8
3	M10×1.5	6.9±1.4	49.9±10.1
4	M12×1.75	12.8±3.0	92.6±21.7

Item	Size	kgf · m	lbf · ft
5	M12×1.75	14.7±2.2	106±15.9
6	M16×2.0	29.7±4.5	215±32.5
7	M20×2.5	57.9±8.7	419±62.9
-	-	-	-

HYDRAULIC COMPONENTS MOUNTING 3

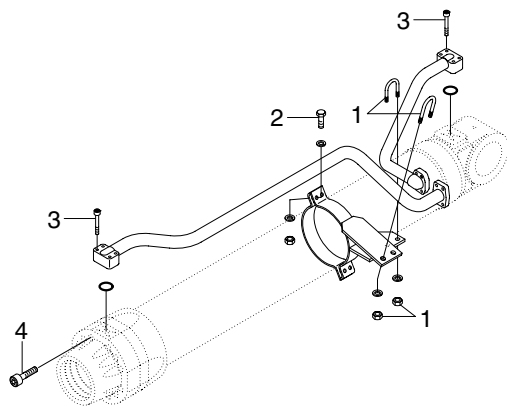

BOOM CYLINDER

Solenoid valve

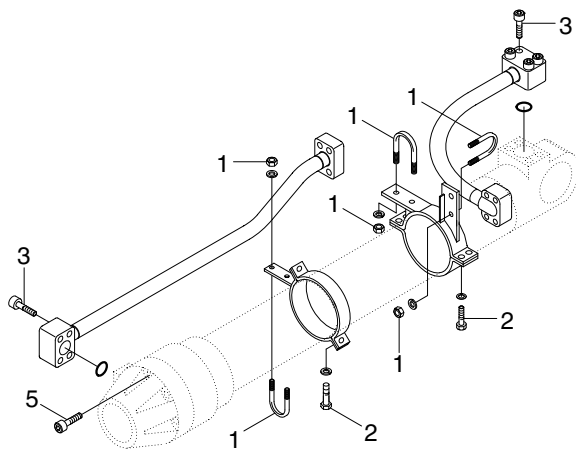
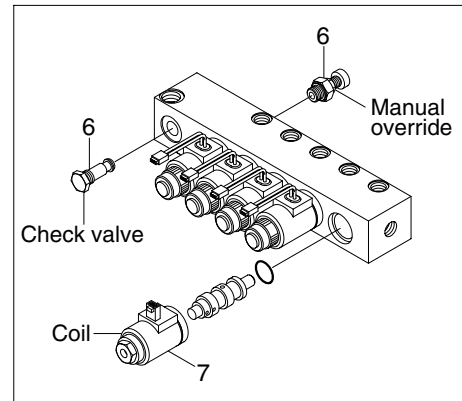

ARM CYLINDER

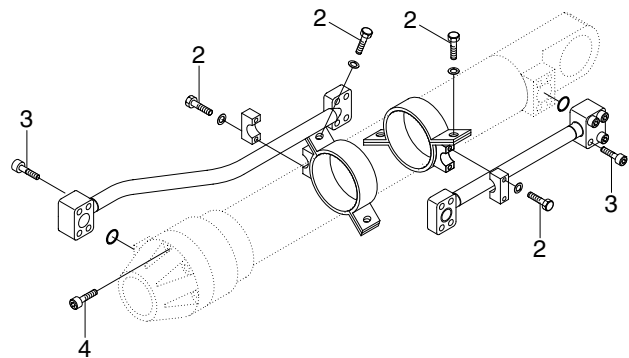

BUCKET CYLINDER

51079CM07

· Tightening torque

Item	Size	kgf · m	lbf · ft
1	M10×1.5	3.2±0.3	23.1±2.2
2	M12×1.75	5.5±0.6	39.8±4.3
3	M12×1.75	9.4±1.0	68.0±7.2
4	M22×2.5	63±6.0	456±43.3

Item	Size	kgf · m	lbf · ft
5	M24×3.0	79±8.0	571±57.9
6	M22×2.5	4.1	29.7
7	M27×3.0	5.1	36.9
-	-	-	-

GROUP 5 UNDERCARRIAGE

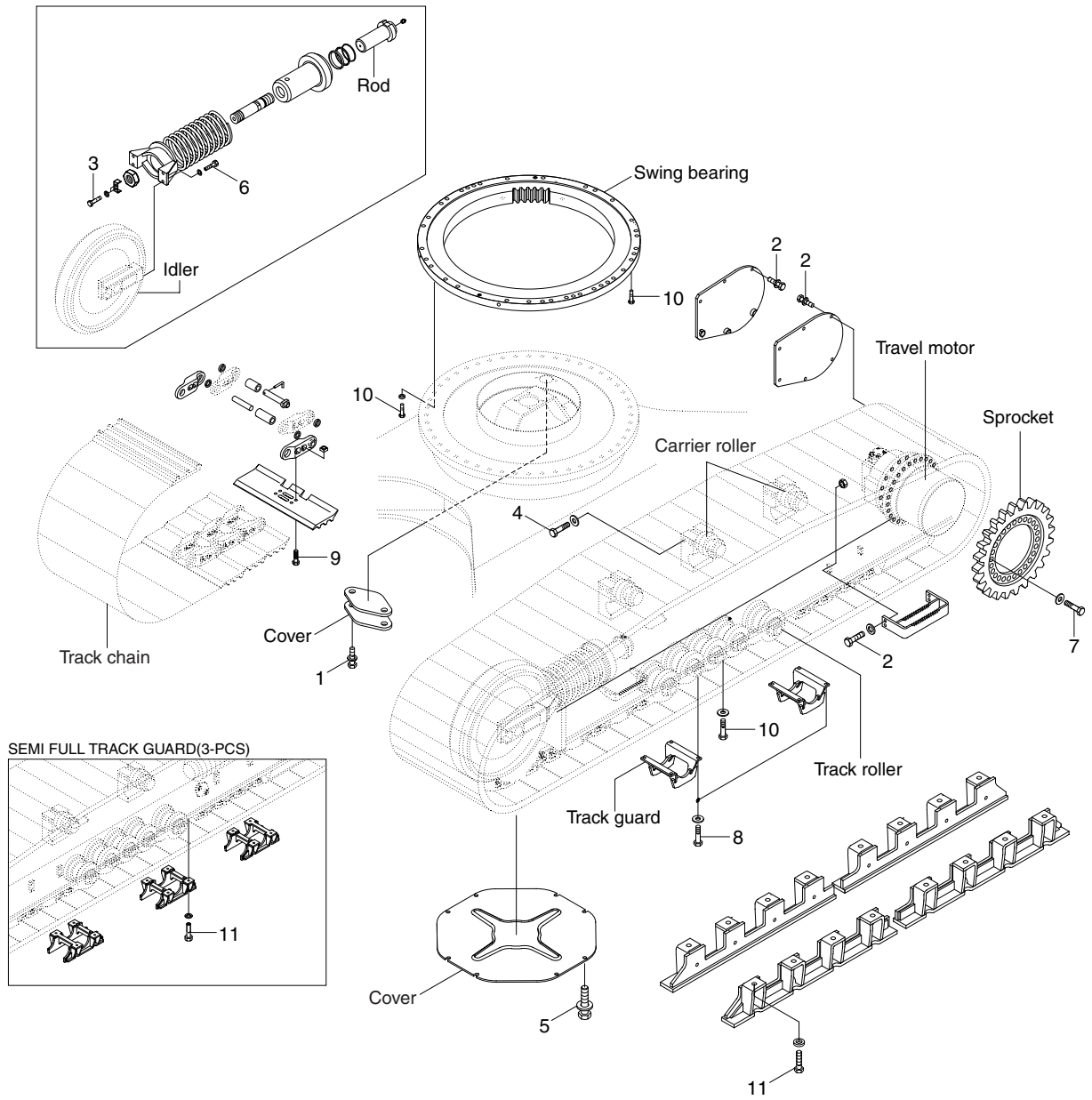

51079CM08

· Tightening torque

Item	Size	kgf · m	lbf · ft
1	M10×1.5	6.9±1.4	49.9±10.1
2	M12×1.75	12.8±3.0	92.6±21.7
3	M14×1.5	21±3.1	152±22.4
4	M16×2.0	29.7±3.0	215±21.7
5	M16×2.0	29.7±4.5	215±32.5

Item	Size	kgf · m	lbf · ft
6	M22×1.5	87.2±12.5	631±90.4
7	M22×2.5	77.4±7.5	560±54.2
8	M22×2.5	81.9±16.1	592±116
9	M24×1.5	140±14	1012±101
10	M24×3.0	100±10	723±72.3

GROUP 6 STRUCTURE

CAB AND ACCESSORIES MOUNTING

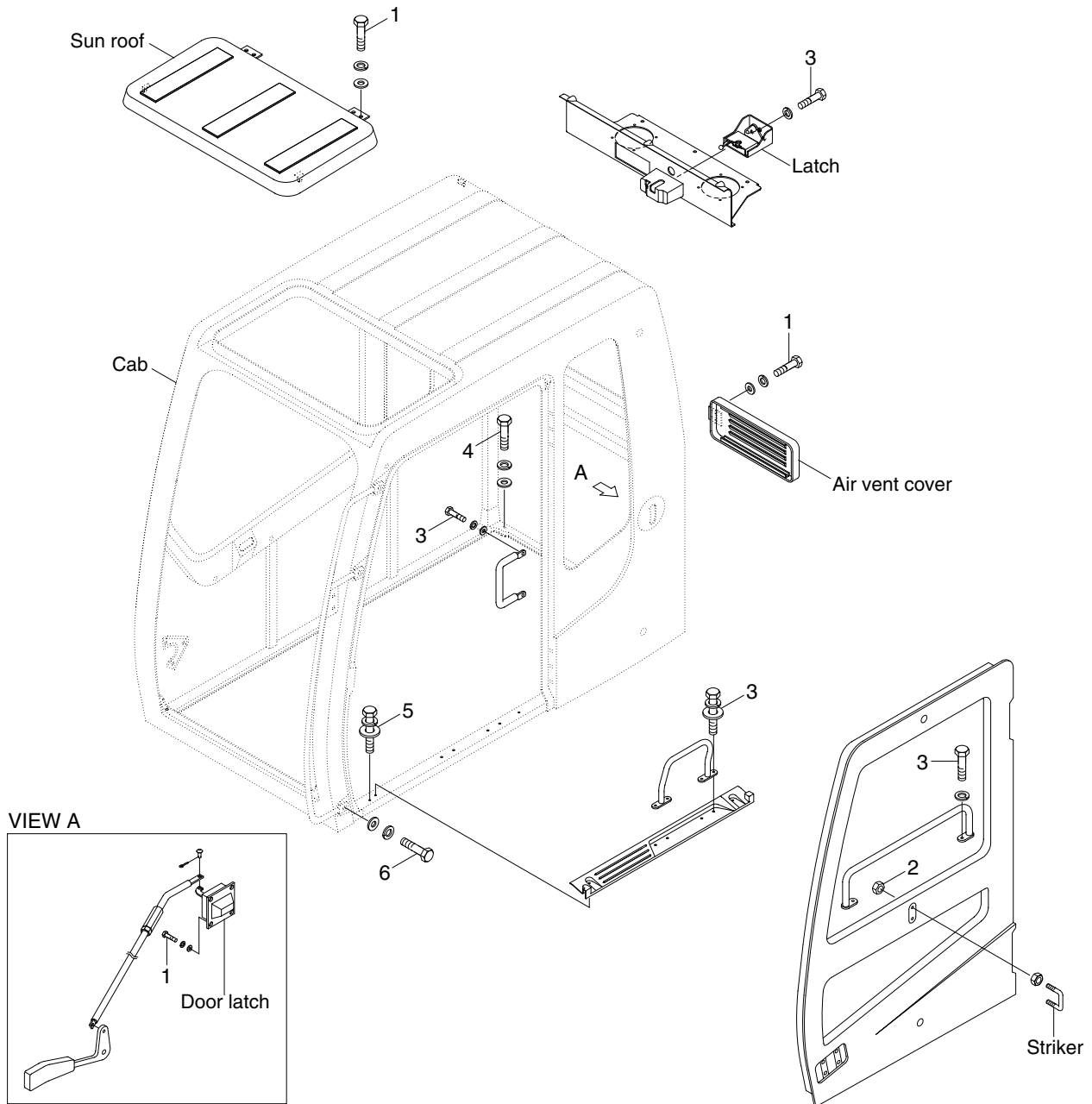

51079CM09

· Tightening torque

Item	Size	kgf · m	lbf · ft
1	M 8×1.25	2.5±0.5	18.1±3.6
2	M10×1.5	4.7±0.9	34.0±6.5
3	M10×1.5	6.9±1.4	49.9±10.1

Item	Size	kgf · m	lbf · ft
4	M12×1.75	12.2±1.3	89.2±9.4
5	M12×1.75	12.8±3.0	92.6±21.7
6	M16×2.0	29.7±4.5	215±32.5

CAB INTERIOR MOUNTING

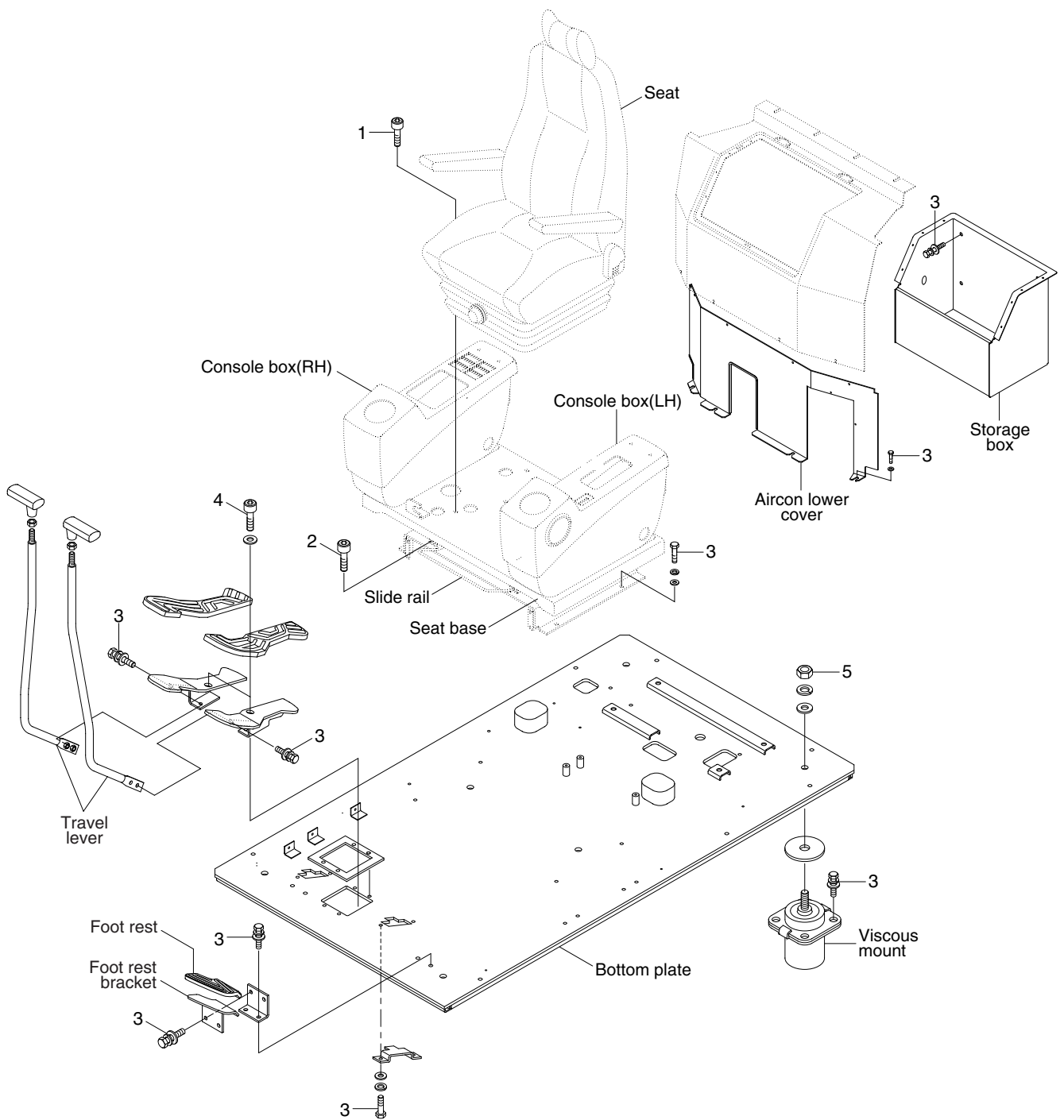

51079CM10

· Tightening torque

Item	Size	kgf · m	lbf · ft
1	M 8×1.25	2.5±0.5	18.1±3.6
2	M 8×1.25	4.05±0.8	29.3±5.8
3	M10×1.5	6.9±1.4	49.9±10.1

Item	Size	kgf · m	lbf · ft
4	M10×1.5	8.27±1.7	59.8±12.3
5	M16×2.0	29.7±4.5	215±32.5
-	-	-	-

COWLING MOUNTING

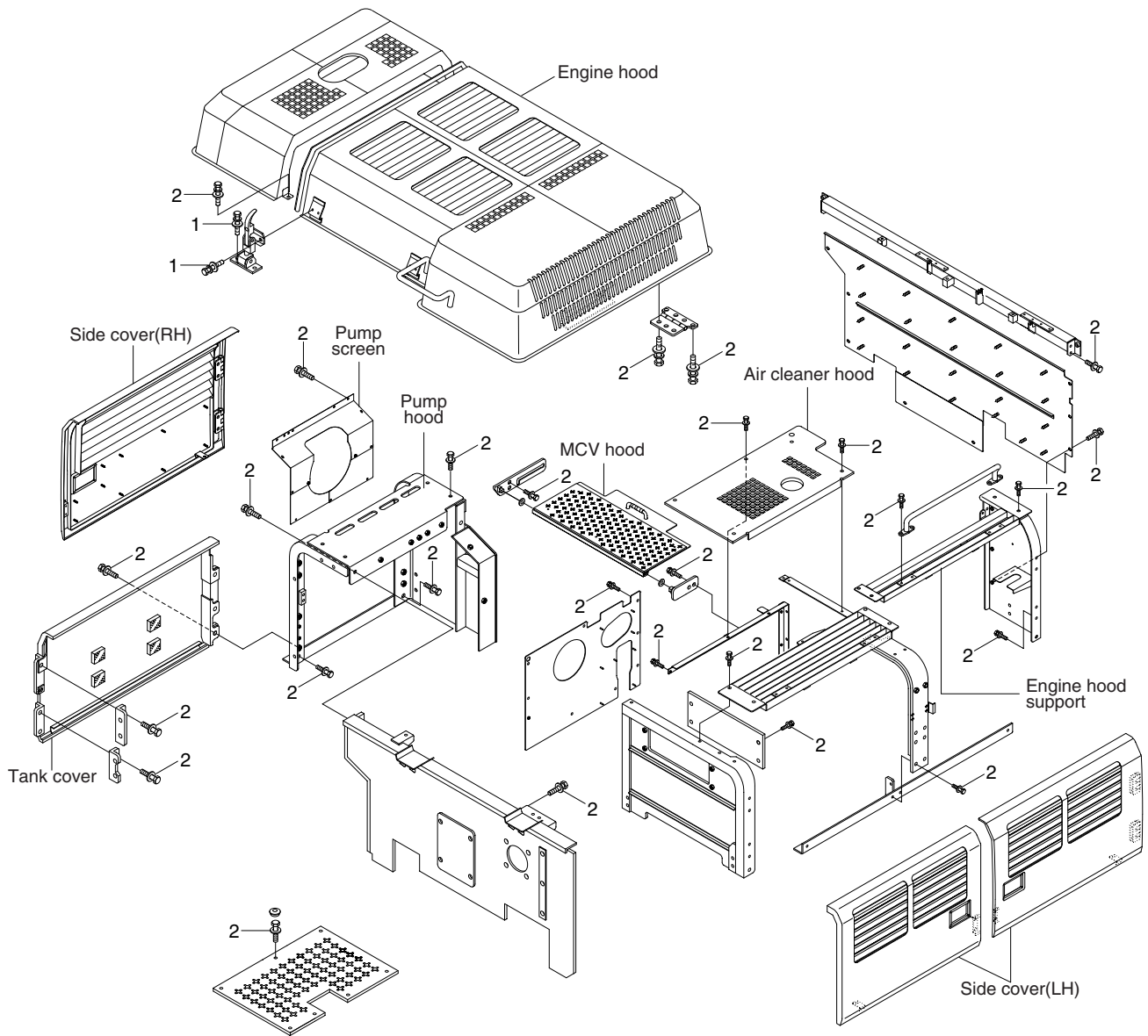

51079CM11

· Tightening torque

Item	Size	kgf · m	lbf · ft
1	M 8×1.25	2.5±0.5	18.1±3.6

Item	Size	kgf · m	lbf · ft
2	M12×1.75	12.8±3.0	92.6±21.7

COUNTERWEIGHT AND COVERS MOUNTING

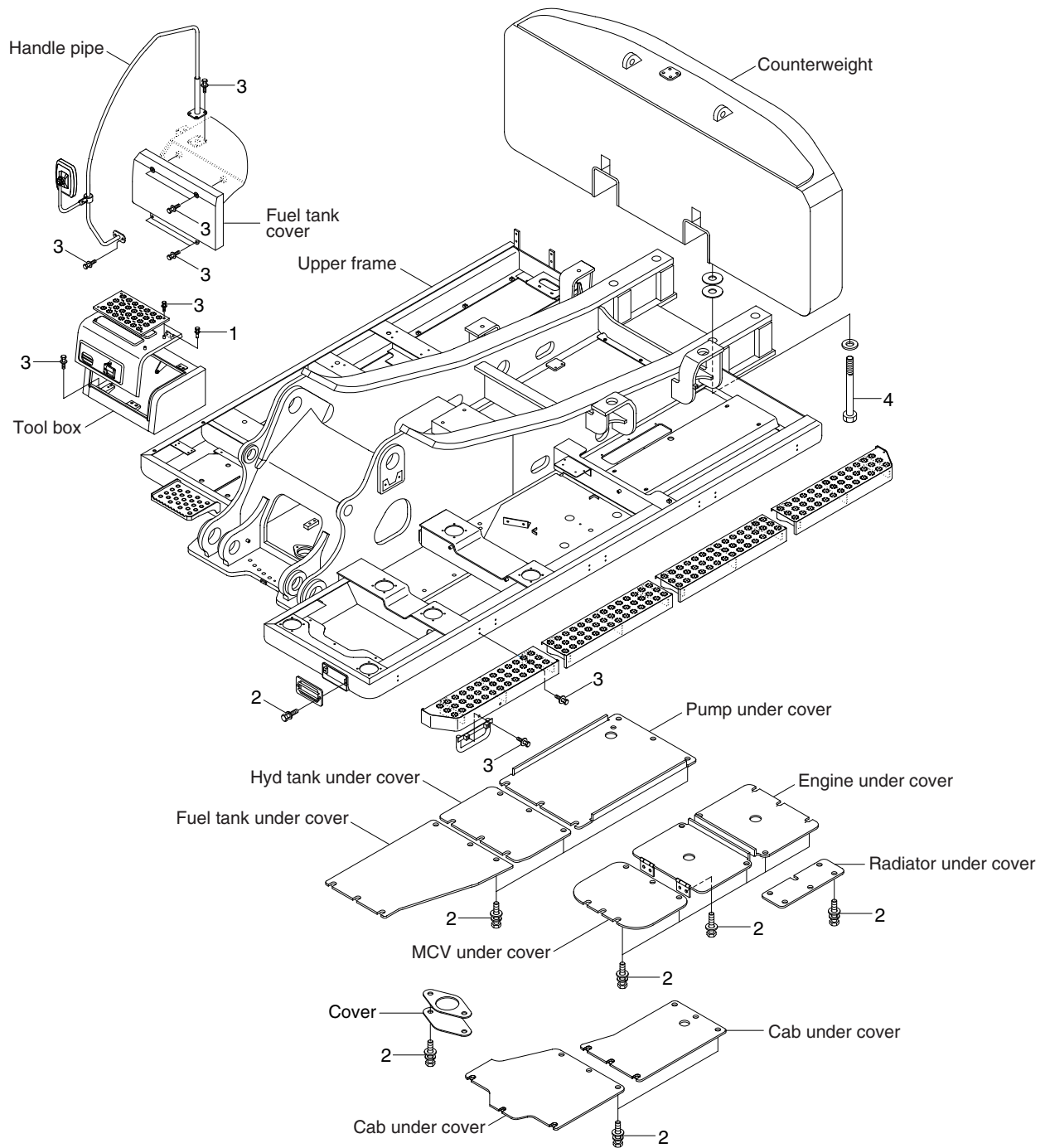

51079CM12

· Tightening torque

Item	Size	kgf · m	lbf · ft
1	M 8×1.25	2.5±0.5	18.1±3.6
2	M10×1.5	6.9±1.4	49.9±10.1

Item	Size	kgf · m	lbf · ft
3	M12×1.75	12.8±3.0	92.6±21.7
4	M42×4.5	390±40	2821±289

GROUP 7 WORK EQUIPMENT

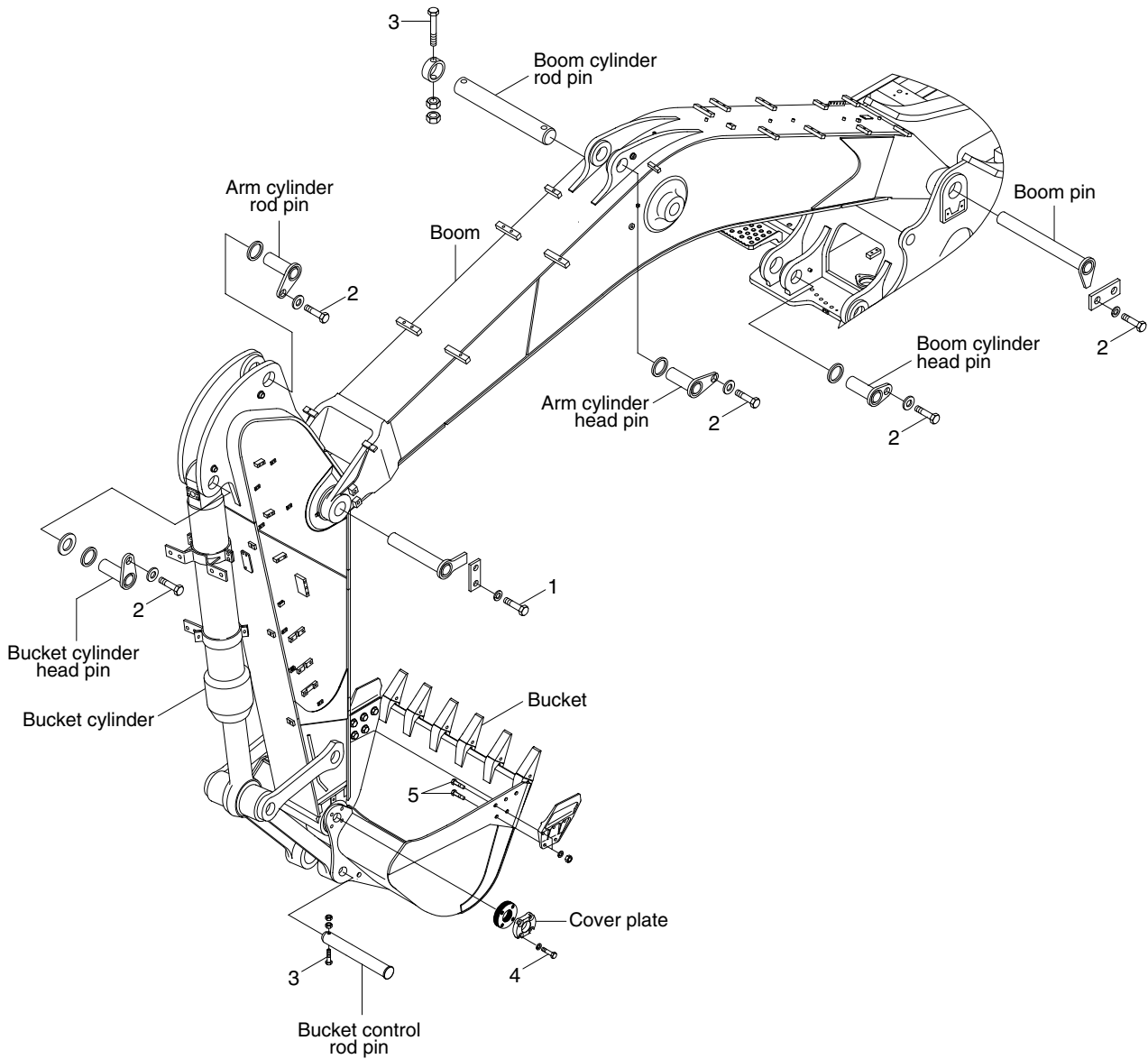

51079CM13

• Tightening torque

Item	Size	kgf · m	lbf · ft
1	M16×2.0	29.7±4.5	215±32.5
2	M20×2.5	57.9±8.7	419±62.9
3	M24×3.0	100±15	723±108

Item	Size	kgf · m	lbf · ft
4	M27×3.0	140±15	1013±108
5	M30×3.5	199±30	1439±217
-	-	-	-