

SECTION 5 MECHATRONICS SYSTEM

Group 1 Outline	5-1
Group 2 Mode Selection System	5-3
Group 3 Automatic Deceleration System	5-6
Group 4 Power Boost System	5-7
Group 5 Travel Speed Control System	5-8
Group 6 Automatic Warming Up Function	5-9
Group 7 Engine Overheat Prevention Function	5-10
Group 8 Anti-Restart System	5-11
Group 9 Self-Diagnostic System	5-12
Group 10 Engine Control System	5-20
Group 11 EPPR(Electro Proportional Pressure Reducing) Valve	5-22
Group 12 Monitoring System	5-25

SECTION 5 MECHATRONICS SYSTEM

GROUP 1 OUTLINE

The NEW CAPO(Computer Aided Power Optimization) system controls engine and pump mutual power at an optimum and less fuel consuming state for the selected work by mode selection, auto-deceleration, power boost function, etc. It monitors machine conditions, for instance, engine speed, coolant temperature, hydraulic oil temperature, and hydraulic oil pressure, etc.

It consists for a MCU, a cluster, an electronic control module (ECM), an EPPR valve, and other components. The MCU and the cluster protect themselves from over-current and high voltage input, and diagnose malfunctions caused by short or open circuit in electric system, and display error codes on the cluster.

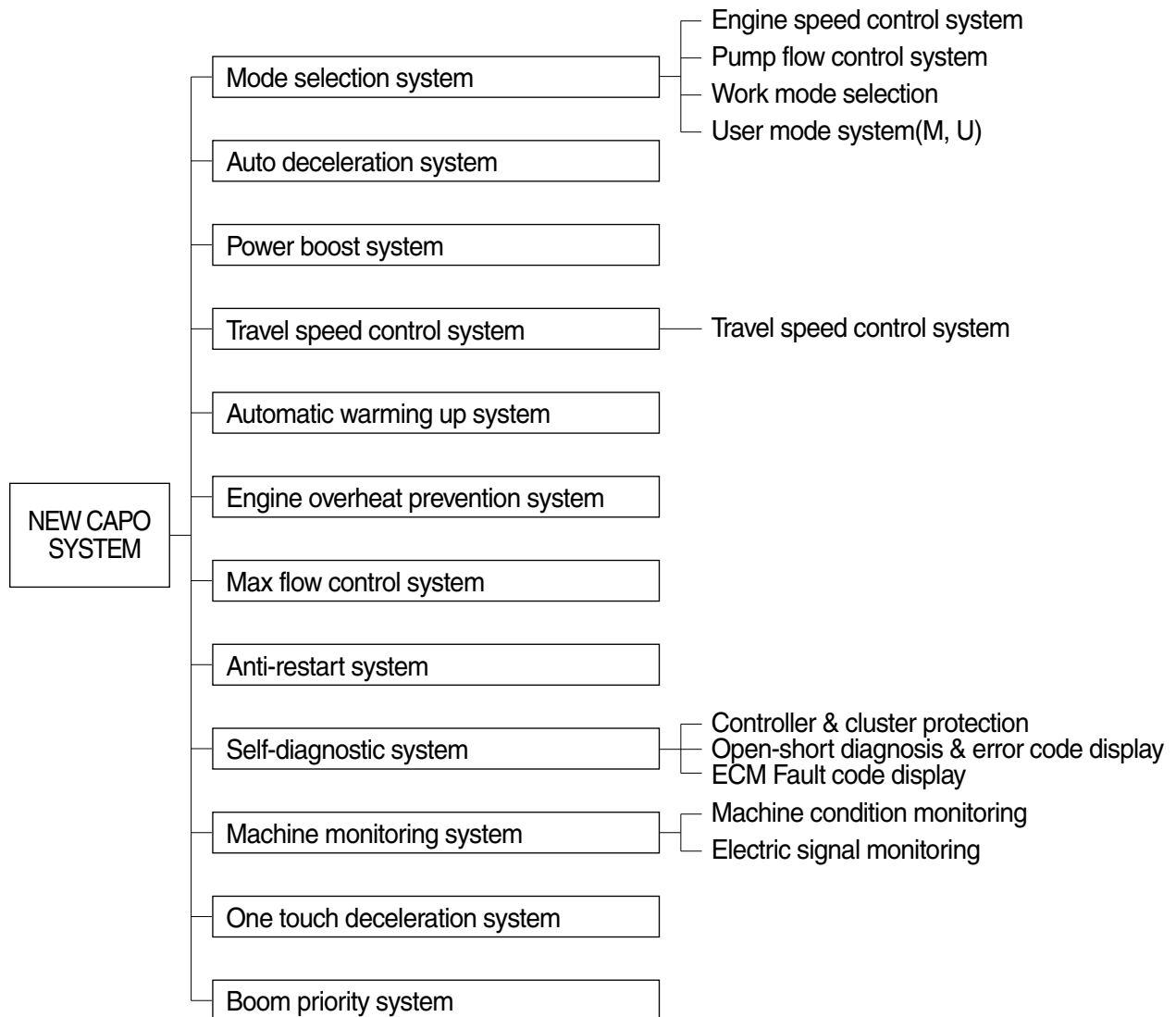

SYSTEM DIAGRAM

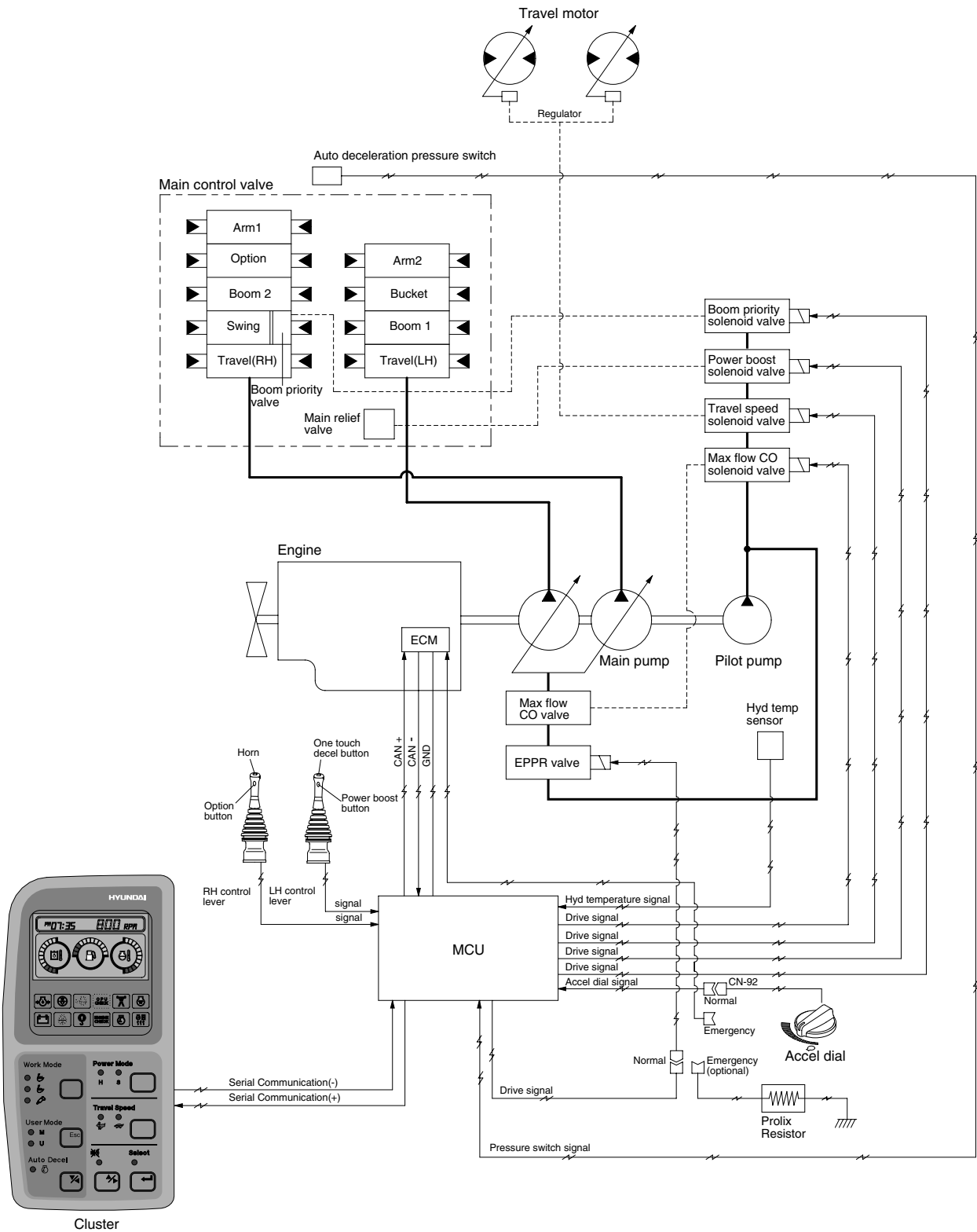

GROUP 2 MODE SELECTION SYSTEM

1. POWER MODE SELECTION SYSTEM

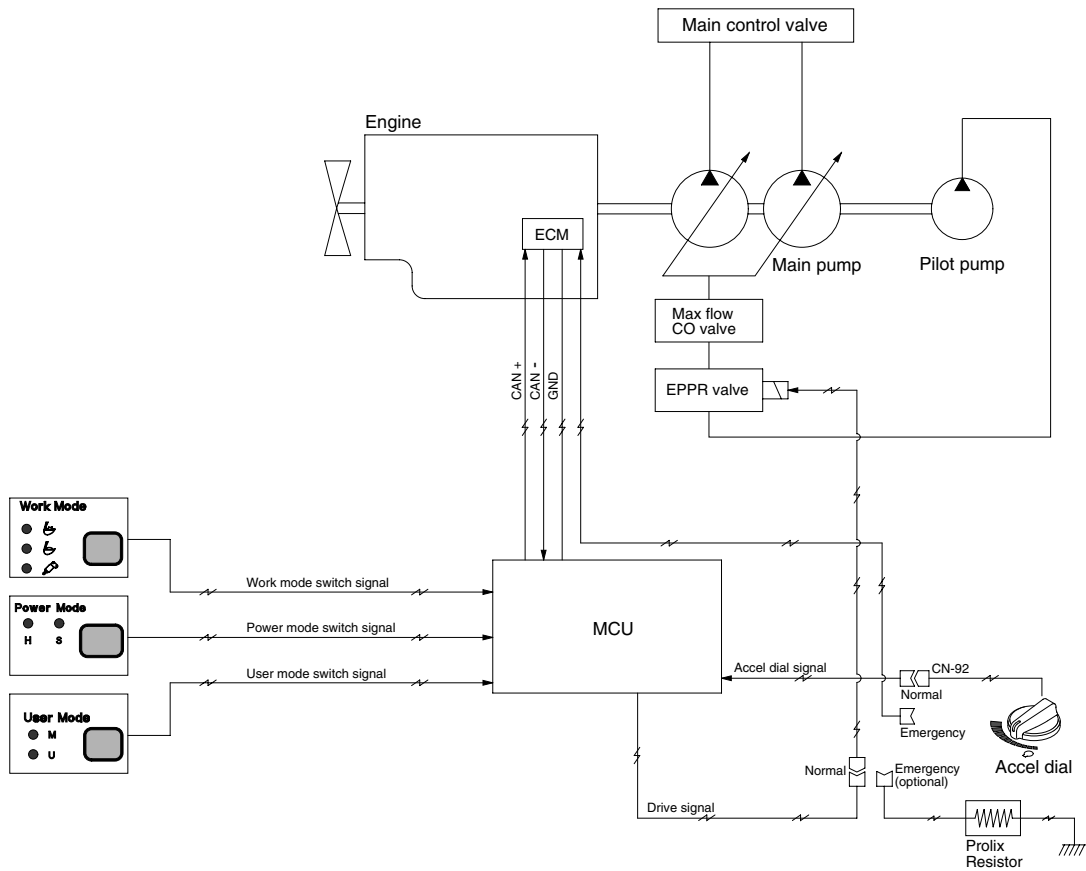

51075MS02

Mode selection system(Micro computer based electro-hydraulic pump and engine mutual control system) optimizes the engine and pump performance.

The combination of 2 power modes(H, S) and accel dial position(10 set) makes it possible to use the engine and pump power more effectively corresponding to the work conditions from a heavy and great power requesting work to a light and precise work.

Mode	Application	Power set (%)	Engine rpm		Power shift by EPPR valve	
			Unload	Load	Current (mA)	Pressure (kgf/cm ²)
M	High power	95	1750±50	1800	360±30	12
H	Standard power	85	1700±50	1750	360±30	12
S	Light power	70	1650±50	1700	360±30	12
AUTO DECEL	Engine deceleration	-	1000±100	-	700±30	38
One touch decel	Engine quick deceleration	-	800±100	-	700±30	38
KEY START	Key switch start position	-	800±100	-	700±30	38

2. WORK MODE SELECTION SYSTEM

3 work modes can be selected for the optional work speed of the machine operation.

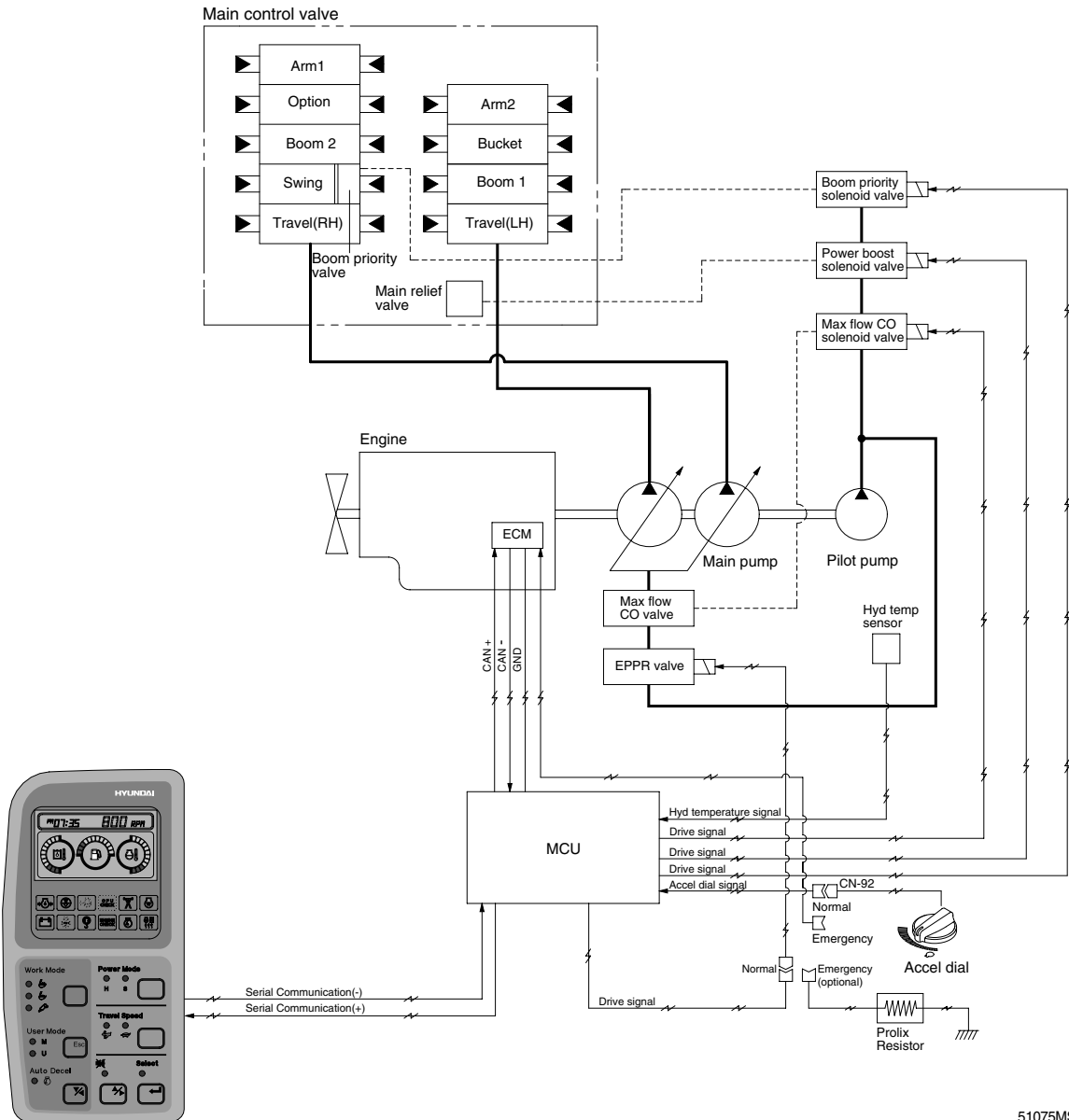

51075MS03

1) HEAVY DUTY WORK MODE

The boom priority solenoid is activated to make the boom operation speed faster.

2) GENERAL WORK MODE

When key switch is turned ON, this mode is selected and swing operation speed is faster than heavy duty work mode.

3) BREAKER OPERATION MODE

It sets the pump flow to the optimal operation of breaker by activating the max flow cut-off solenoid.

Work mode	Boom priority solenoid	Max flow cut-off solenoid
Heavy duty	ON	OFF
General	OFF	OFF
Breaker	OFF	ON

3. USER MODE SELECTION SYSTEM

An operator can change the engine and pump power and memorize it for his preference.

Mode	Operation
U	High idle rpm, auto decel rpm EPPR pressure can be modulated and memorized separately

HOW TO MODULATE THE MEMORY SET

- Each memory mode has a initial set which are mid-range of max engine speed, auto decel rpm, and EPPR valve input current. When you select M or U, cluster LCD displays.
- To change the engine high idle speed, press the USER mode switch and SELECT switch at the same time and then ACCEL blinks at 0.5 seconds interval.
 - By pressing ▲ or ▼ switch, █ will increase or decrease.
- To change DECEL rpm, press the USER mode switch and SELECT switch once more and then DECEL blinks at 0.5 seconds interval.
 - By pressing ▲ or ▼ switch, █ will increase or decrease.
- To change EPPR current, press the USER mode switch and SELECT switch one more and then EPPR blinks at 0.5 seconds interval.
 - By pressing ▲ or ▼ switch, █ will increase or decrease.

· LCD segment vs parameter setting

Segment (█)	ACCEL (rpm)	DECEL (rpm)	EPPR (mA)
1	1400	800	150
2	1450	850	200
3	1500	One touch decel low idle(900)	250
4	1550	950	300
5	1600	Decel rpm(1000)	350
6	1650	1050	400
7	1700	1100	450
8	1750	1150	500
9	1800	1200	550
10	1850	1250	600

- To memorize the final setting, press the USER mode switch and SELECT switch one more time.

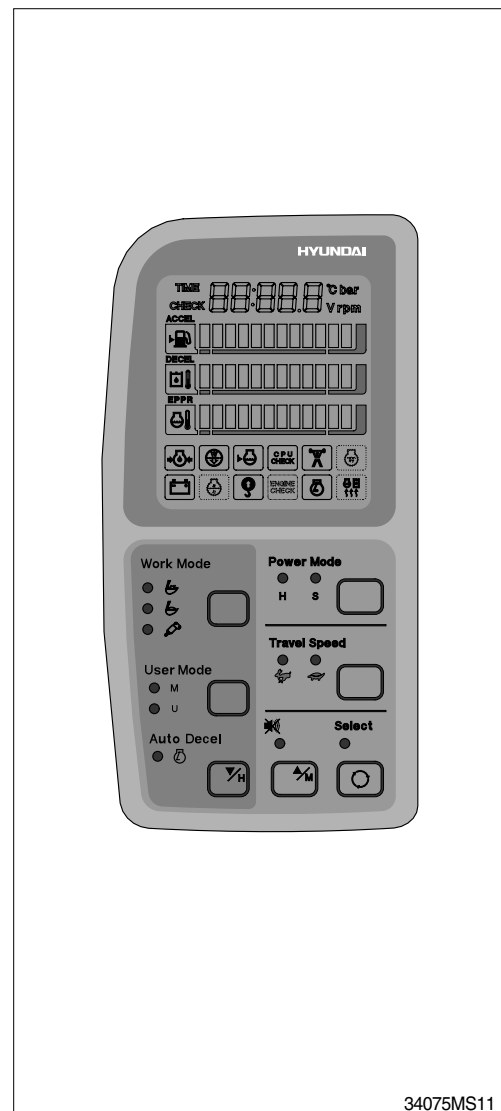
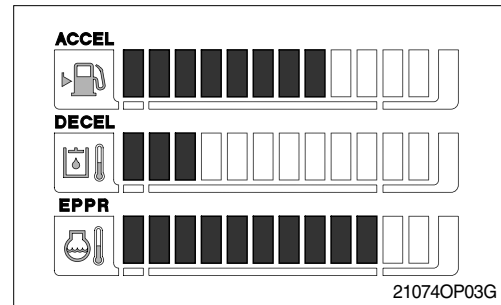

GROUP 3 AUTOMATIC DECELERATION SYSTEM

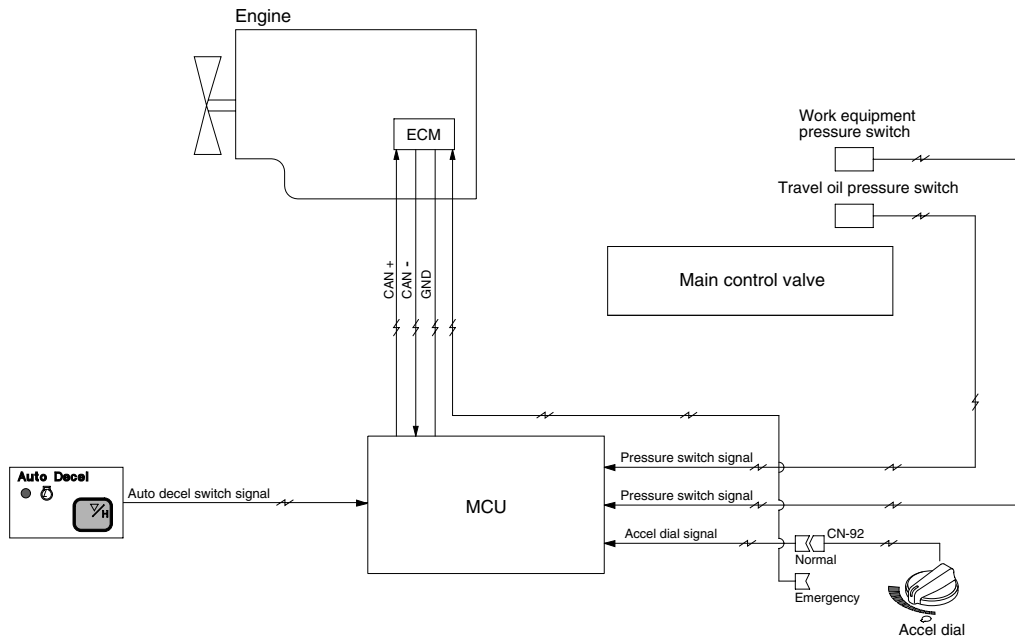

51075MS04

1. WHEN AUTO DECEL LAMP ON

If all the work equipment control levers including swing and travel levers are at neutral for at least 4 seconds, MCU transmits the throttle command to ECM to reduce the engine speed to 1000rpm. As the result of reducing the engine speed, fuel consumption and noise are effectively cut down during non-operation of the control levers.

When the Auto decel lamp is turned off by pressing the switch or any control lever is operated, the reduced engine speed rises upto the speed set before deceleration in a second.

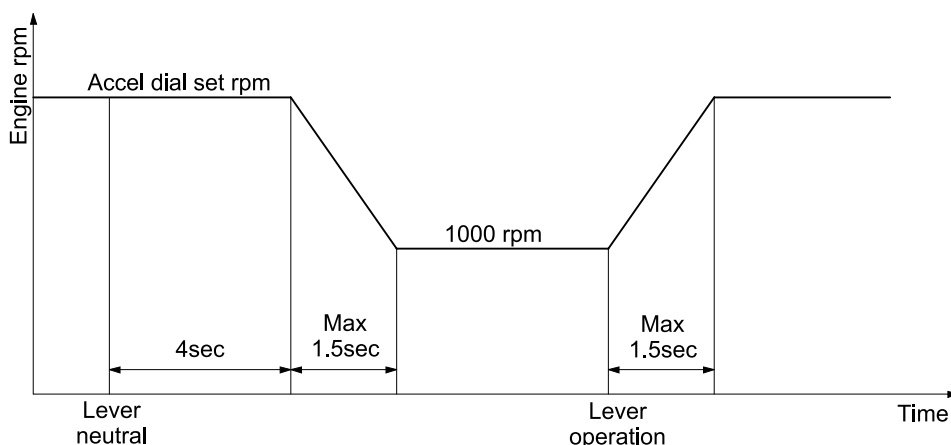

45075MS05

2. WHEN AUTO DECEL LAMP OFF

The engine speed can be set as desired using the engine speed switch, and even if the control levers are neutral, the engine speed is not reduced.

※ **Auto decel function can be activated when accel dial position is over 4.**

GROUP 4 POWER BOOST SYSTEM

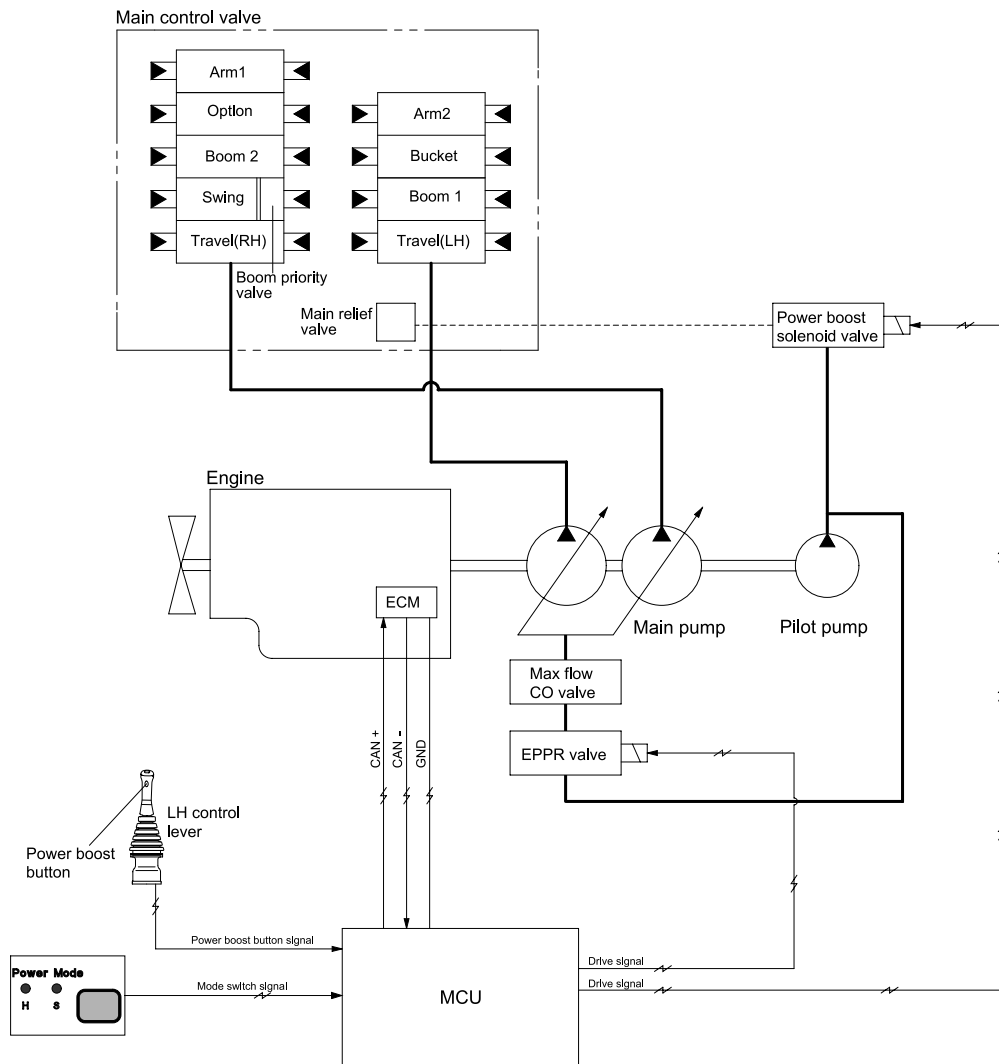

51075MS04

- When the power boost switch on the left control lever knob is pushed ON, the maximum digging power is increased by 10%.
- When the power set is at H or S and the power boost function is activated, the power boost solenoid valve pilot pressure raises the set pressure of the main relief valve to increase the digging power.

Description	Power boost switch	
	OFF	ON
Power set	H or S	H
Main relief valve set pressure	330kgf/cm ²	360kgf/cm ²
Time of operation	-	Even when pressed continuously, it is canceled after 8 sec.

※ Default - Power boost solenoid valve : OFF

GROUP 5 TRAVEL SPEED CONTROL SYSTEM

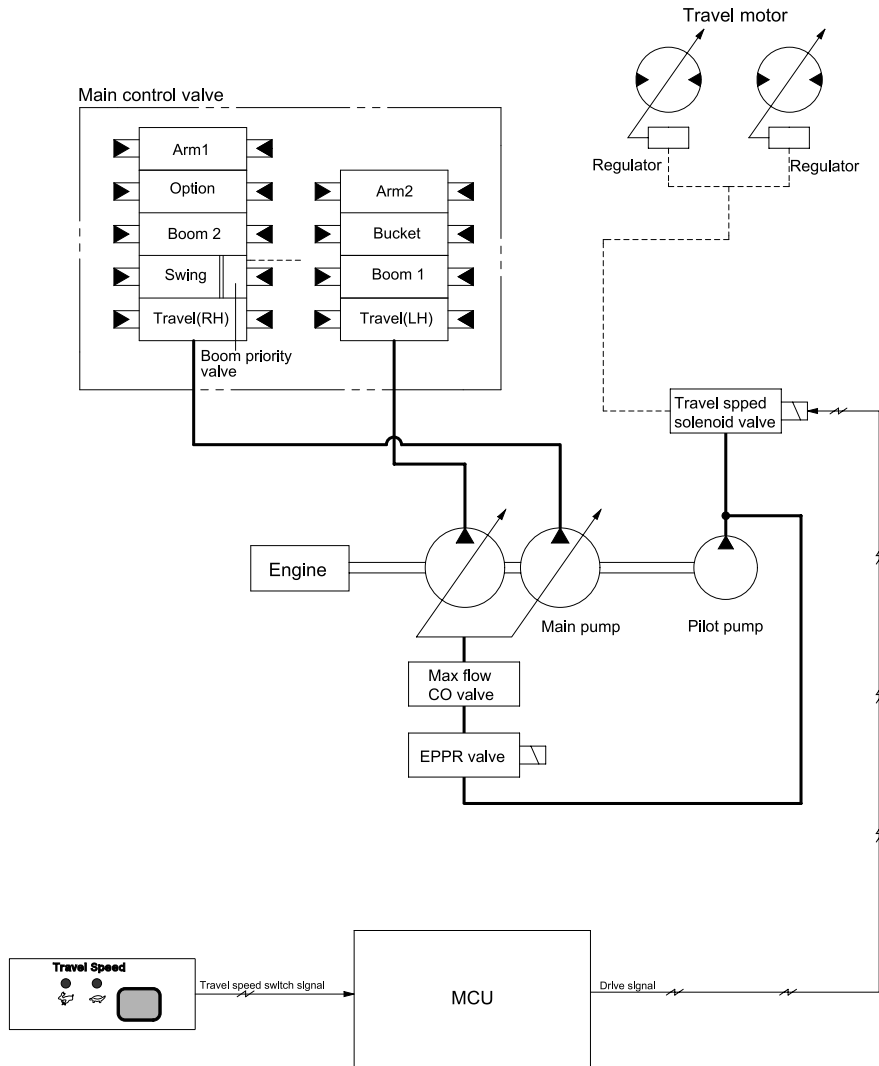

51075MS06

Travel speed can be switched manually by pressing the travel speed switch on the cluster.

Speed	Travel speed solenoid valve	Lamp on cluster	Operation
Lo	OFF	Turtle	Low speed, high driving torque in the travel motor
Hi	ON	Rabbit	High speed, low driving torque in the travel motor

※ Default : Turtle(Lo)

GROUP 6 AUTOMATIC WARMING UP FUNCTION

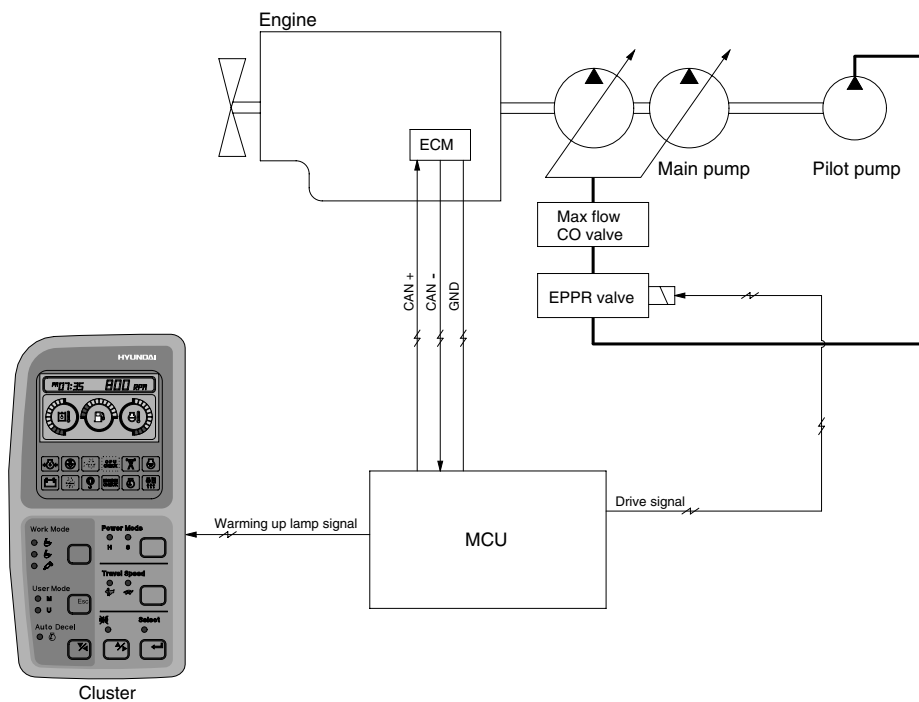

51075MS07

1. MCU receives engine coolant temperature from the ECM, and if the coolant temperature is less than 30°C, it increases the engine speed from key start rpm to 1000rpm. At this time the mode does not change.
2. In case of the coolant temperature increases up to 30°C, the engine speed is decreased to key start speed. And if an operator changes mode set during the warming up function, the MCU cancels the automatic warming up function.

3. LOGIC TABLE

Description	Condition	Function
Actuated	<ul style="list-style-type: none"> - Coolant temperature : Less than 30° C (After engine run) - Accel dial position is under 3 	<ul style="list-style-type: none"> - Mode : Default(S mode) - Warming up time : 10 minutes(Max) - Warming up lamp : ON
Canceled	<ul style="list-style-type: none"> - Coolant temperature : Above 30°C - Warming up time : Above 10 minutes - Changed mode set by operator - Increase engine speed by rotating accel dial clockwise <p>※ If any of the above conditions is applicable, the automatic warming up function is canceled</p>	<ul style="list-style-type: none"> - Default mode - Default mode - Changed mode
Warming up lamp	<ul style="list-style-type: none"> - Coolant temperature : Above 30°C 	<ul style="list-style-type: none"> - Warming up lamp : OFF

GROUP 7 ENGINE OVERHEAT PREVENTION FUNCTION

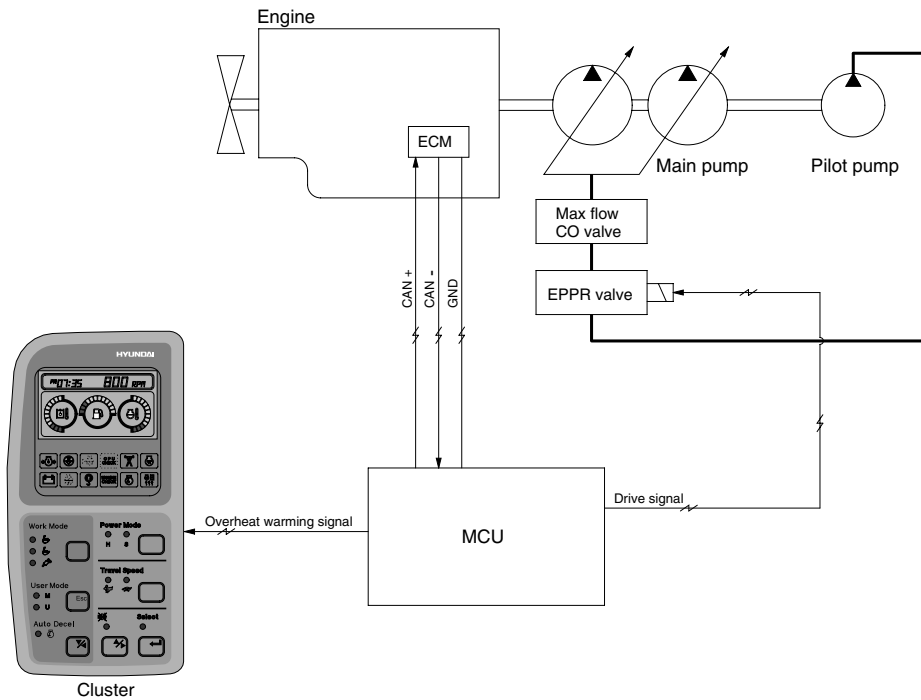

51075MS08

1. MCU receives engine coolant temperature from the ECM and when the engine coolant boils up to 110°C, it sends overheat warning signal to the cluster and decrease the engine speed same as accel dial 7 position.
2. If the coolant temperature drops less than 100°C, the MCU returns the mode to the mode set before. And if mode set is changed during the function, the MCU cancels the function. Even if the overheat prevention function is canceled by mode change, the overheat warning lamp turns OFF only when the coolant temperature is less than 100°C.

3. LOGIC TABLE

Description	Condition	Function
Actuated	- Coolant temperature : Above 110°C - Accel dial set : Above 8	- Engine rpm drop to accel dial 7 position - Overheat warning lamp & buzzer : ON
Canceled	- Coolant temperature : Less than 100°C - Changed mode set by operator ※ If any of the above conditions is applicable, engine overheat prevention function is canceled	- Return to the mode and accel dial set before - Hold on the changed set
Overheat warning lamp	- Coolant temperature : Less than 100°C	- Overheat warning lamp : OFF

GROUP 8 ANTI-RESTART SYSTEM

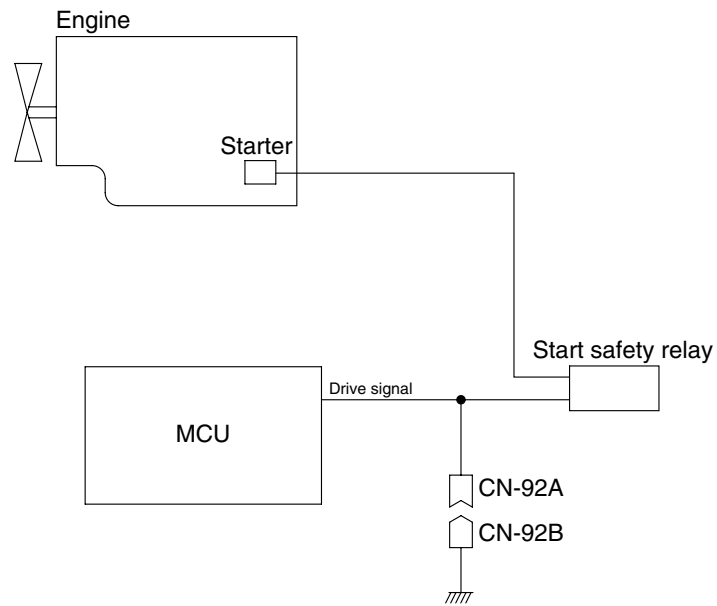

51075MS10

1. ANTI-RESTART FUNCTION

After 10 seconds from the engine starts to run, MCU turns off the start safety relay to protect the starter from inadvertent restarting.

2. When a replacement or taking-off of the MCU is needed, connect CN-92a and CN-92b to ensure the engine start without the MCU.

GROUP 9 SELF-DIAGNOSTIC SYSTEM

1. OUTLINE

When any abnormality occurs in the NEW CAPO system caused by electric parts malfunction and by open or short circuit, the MCU controller diagnoses the problem and sends the error codes to the cluster and also stores them in the memory.

The current or recorded error codes are displayed at the error display mode selected by touching **SELECT** switch 2 times while pressing **BUZZER STOP** switch.

2. CURRENT ERROR DISPLAY

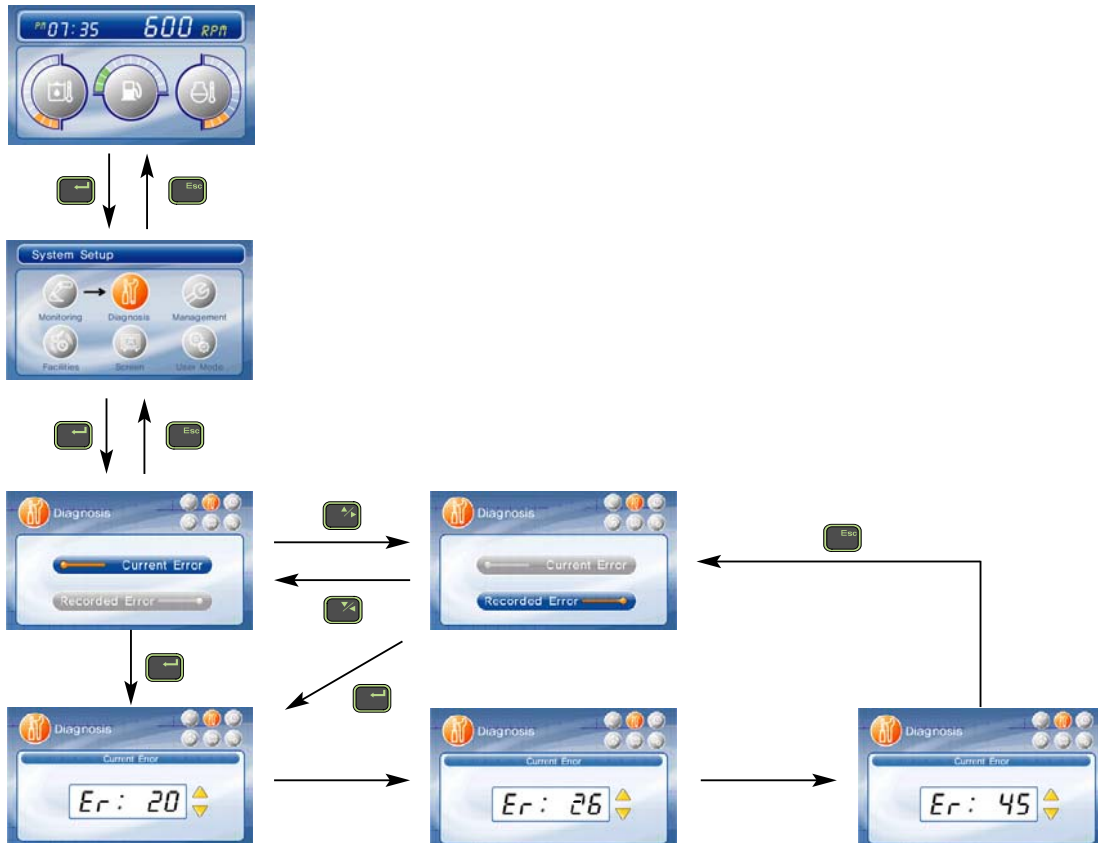

3. ERROR CODES TABLE

Error code No.	Description
1	Short circuit in accel actuator system
2	Potentiometer circuit is shorted to Vcc(5V) or battery +
3	Short circuit in pump EPPR valve system
4	Short circuit in boom down EPPR valve system
5	Short circuit in travel speed solenoid system
6	Short circuit in power boost solenoid system
7	Short circuit in max flow solenoid system
10	Short circuit in hour-meter system
11	Accel dial circuit is shorted to Vcc(5V) or battery +
12	P1 pressure sensor circuit is shorted to power supply(24V) line
13	P2 pressure sensor circuit is shorted to power supply(24V) line
14	P3 pressure sensor circuit is shorted to power supply(24V) line
15	Boom down pressure circuit is shorted to power supply(24V) line
16	Accel actuator circuit is open or shorted to ground
17	Potentiometer circuit is open or shorted to ground
18	Pump EPPR valve circuit is open or shorted to ground
19	Boom down EPPR valve circuit is open or shorted to ground
20	Travel speed solenoid circuit is open or shorted to ground
21	Power boost solenoid circuit is open or shorted to ground
22	Max flow solenoid circuit is open or shorted to ground
25	Hour-meter circuit is open or shorted to ground
26	Accel dial circuit is open or shorted to ground
27	P1 pressure sensor circuit is open or shorted to ground
28	P2 pressure sensor circuit is open or shorted to ground
29	P3 pressure sensor circuit is open or shorted to ground
30	Boom down pressure sensor circuit is open or shorted to ground
31	Engine preheater circuit is open or shorted to ground
32	Travel alarm buzzer circuit is open or shorted to ground
33	Alternator circuit is open or shorted to ground
34	Controller input voltage is below 18V
35	Controller input voltage is over 38V
36	Communication error with cluster
37	Engine speed sensor circuit is open or shorted to ground
38	Anti-restart relay circuit is open or shorted to ground
39	Accel actuator does not stop at a target position
40	There is more than 500rpm difference between target speed and actual speed

Error code No.	Description
41	Hydraulic oil temperature sensor circuit is shorted to ground
42	Fuel level sensor circuit is shorted to ground
43	Coolant temperature sensor circuit is shorted to ground
44	Boom up pressure sensor circuit is shorted to power supply(24V) line
45	Hydraulic oil temperature sensor circuit is open or shorted to battery +
46	Fuel level sensor circuit is open or shorted to battery +
47	Coolant temperature sensor circuit is open or shorted to battery +
48	Boom up pressure sensor circuit is open or shorted to ground
49	Engine preheater circuit is shorted to battery +
51	Boom priority solenoid circuit is open or shorted to ground
56	Travel alarm buzzer circuit is shorted to battery +
58	Boom priority solenoid circuit is shorted to battery +

4. ENGINE FAULT CODE INFORMATION (For QSM11)

Fault code No.	Reason	Effect(only when fault code is active)
111	Error internal to the ECM related to memory hardware failures or internal ECM voltage supply circuits.	Engine will not start.
115	No engine speed signal detected at both engine position sensor circuits.	Engine will die and will not start.
121	No engine speed signal detected from one of the engine position sensor circuits.	None on performance.
122	High voltage detected on the intake manifold pressure circuit.	Derate in power output of the engine.
123	Low voltage detected on the intake manifold pressure circuit.	Derate in power output of the engine.
131	High voltage detected at the throttle position signal circuit.	Severe derate(power and speed). Limp home power only.
132	Low voltage detected at the throttle position signal circuit.	Severe derate(power and speed). Limp home power only.
133	High voltage detected at the remote throttle position signal circuit.	None on performance if remote throttle is not used.
134	Low voltage detected at the remote throttle position signal circuit.	None on performance if remote throttle is not used.
135	High voltage detected at the oil pressure circuit.	No engine protection for oil pressure.
141	Low voltage detected at the oil pressure circuit.	No engine protection for oil pressure.
143	Oil pressure signal indicates oil pressure below the low oil pressure engine protection limit.	Progressive power and speed derate with increasing time after alert. If engine protection shutdown feature is enable, engine will shut down 30 seconds after red lamp starts flashing.
144	High voltage detected at the coolant temperature circuit.	Possible white smoke. Fan will stay on if controlled by the electronic control module (ECM). No engine protection for coolant temperature.
145	Low voltage detected at the coolant temperature circuit.	Possible white smoke. Fan will stay on if controlled by electronic control module (ECM). No engine protection for coolant temperature.
147	A frequency of less then 100Hz was detected at the frequency throttle signal pin of the actuator harness connector at the ECM.	Calibration dependent power and speed derate.
148	A frequency of more than 100Hz was detected at the frequency throttle signal pin of the actuator harness connector at the ECM.	Calibration dependent power and speed derate.
151	Coolant temperature signal indicates coolant temperature above 104° C(220°F).	Progressive power derate with increasing time after alert. If engine protection shutdown feature is enabled, engine will shut down 30 seconds after red lamp starts flashing.
153	High voltage detected at the intake manifold temperature circuit.	Possible white smoke. Fan will stay on if controlled by electronic control module (ECM). No engine protection for coolant temperature.
154	Low voltage detected at the intake manifold temperature circuit.	Possible white smoke. Fan will stay on if controlled by electronic control module (ECM). No engine protection for coolant temperature.
155	Intake manifold temperature signal indicates temperature above 87.8° C(190°F).	Progressive power derate with increasing time after alert. If engine protection shutdown feature is enabled, engine will shut down 30 seconds after red lamp starts flashing.
187	Low voltage detected on the ECM voltage supply line to some sensors(VSEN2 supply).	Engine will run derated. No engine protection for oil pressure and coolant level.

Fault code No.	Reason	Effect(only when fault code is active)
211	Additional machine diagnostic codes have been logged. Check other ECM's for diagnostic codes.	None on engine performance.
212	High voltage detected at the oil temperature circuit.	No engine protection for oil temperature.
213	Low voltage detected at the oil temperature circuit.	No engine protection for oil temperature.
214	Oil temperature signal indicates oil temperature above 123.9° C(225° F).	Progressive power derate with increasing time after alert. If engine protection shutdown feature is enabled, engine will shut down 30sec after the red lamp starts flashing.
219	Low oil level was detected in the Centinel™ makeup oil tank.	None on performance. Centinel™ deactivated.
221	High voltage detected at the ambient air pressure circuit.	Derate in power output of the engine.
222	Low voltage detected at the ambient air pressure circuit.	Derate in power output of the engine.
223	Incorrect voltage detected at the Centinal™ actuator circuit by the ECM.	None on performance. Centinel™ deactivated.
227	High voltage detected on the ECM voltage supply line to some sensors(VSEN2 supply).	Engine will run derated. No engine protection for oil pressure and coolant level.
234	Engine speed signal indicates engine speed is greater than 2730 rpm.	Fuel shutoff valve closes until engine speed falls to 2184 rpm.
235	Coolant level signal indicates coolant level is below the normal range.	Progressive power derate with increasing time after alert. If engine protection shutdown feature is enabled, engine will shut down 30 seconds after red lamp starts flashing.
237	Duty cycle of the throttle input signal to the primary or secondary engine for multiple unit synchronization is less than 3 percent or more than 97 percent.	All engines(primary and secondary) are shut down with increasing time after alert if hard-coupled. Only secondary engines are shut down with increasing time after alert if soft-coupled.
241	The ECM lost the vehicle speed signal.	Engine speed limited to maximum engine speed without vehicle speed sensor parameter value Cruise Control. Gear-Down Protection and Road Speed Governor will not work (automotive only).
242	Invalid or inappropriate vehicle speed signal detected. Signal indicates an intermittent connection or VSS tampering.	Engine speed limited to maximum engine speed without vehicle speed sensor parameter value Cruise Control. Gear-Down Protection and Road Speed Governor will not work (automotive only).
245	Less than 6 VDC detected at fan clutch circuit when on. Indicates an excessive current draw from the ECM or faulty ECM output circuit.	The fan may stay on at all times.
254	Less than 6 VDC detected at FSO circuit when on. Indicates an excessive current draw from the ECM or a faulty ECM output circuit.	The ECM turns off the FSO supply voltage. The engine will shut down.
255	Externally supplied voltage detected going to the fuel shutoff solenoid supply circuit.	None on performance. Fuel shutoff valve stays open.
285	The ECM expected information from a multiplexed device but did not receive it soon enough or did not receive it at all.	At least one multiplexed device will not operate properly.
286	The ECM expected info from a multiplexed device but only received a portion of the necessary information.	At least on multiplexed device will not operate properly.
287	The machine vehicle electronic control unit (VECU) detected a fault with its throttle pedal.	The engine will only idle.

Fault code No.	Reason	Effect(only when fault code is active)
288	The machine vehicle electronic control unit (VECU) detected a fault with its remote throttle.	The engine will not respond to the remote throttle.
293	High voltage detected at the machine temperature sensor signal pin of the 31-pin machine connector.	No engine protection for machine temperature.
294	Low voltage detected at the machine temperature sensor signal pin of the 31-pin machine connector.	No engine protection for machine temperature.
295	An error in the ambient air pressure sensor signal was detected by the ECM.	Engine is derated to no air setting.
297	High voltage detected at the machine pressure sensor signal pin of the 31-pin machine connector.	No engine protection for machine pressure.
298	Low voltage detected at the machine pressure sensor signal pin of the 31-pin machine connector.	No engine protection for machine pressure.
299	Engine shutdown by device other than key switch before proper engine cool down resulting in filtered load factor above maximum shutdown threshold.	No action taken by the ECM.
311	Current detected at No.1 injector when voltage is turned off.	Current to injector is shut off.
312	Current detected at No.5 injector when voltage is turned off.	Current to injector is shut off.
313	Current detected at No.3 injector when the voltage is turned off	Current to injector is shut off.
314	Current detected at No 6 injector when the voltage is turned off.	Current to injector is shut off.
315	Current detected at No.2 injector when the voltage is turned off.	Current to injector is shut off.
319	Real time clock lost power.	None on performance. Data in the ECM will not have accurate time and date information.
321	Current detected at No.4 injector when the voltage is turned on.	Current to injector is shut off.
322	No current detected at No.1 injector when the voltage is turned on.	Current to injector is shut off.
323	No current detected at No.5 injector when the voltage is turned on.	Current to injector is shut off.
324	No current detected at No.3 injector when the voltage is turned on.	Current to injector is shut off.
325	No current detected at No.6 injector when the voltage is turned on.	Current to injector is shut off.
331	No current detected at No.2 injector when the voltage is turned on.	Current to injector is shut off.
332	No current detected at No.4 injector when the voltage is turned on.	Current to injector is shut off.
341	Severe loss of data from the ECM.	Possible no noticeable performance effects OR engine dying OR hard starting. Fault information, trip information and maintenance monitor data may be inaccurate.
343	Internal ECM error.	Possible none on performance or severe derate.
349	A frequency greater than calibrated threshold was detected at the tail shaft governor signal pin of the 31-pin machine connector.	Calibration dependent power and speed derate.
352	Low voltage detected on the ECM voltage supply line to some sensors (VSEN 1 supply).	Engine is derated to no air setting.

Fault code No.	Reason	Effect(only when fault code is active)
386	High voltage detected on the ECM voltage supply line to some sensors (VSEN 1 supply).	Engine is derated to no air setting.
387	High voltage detected on the ECM voltage supply line to the throttle(VTP supply).	Engine will only idle.
415	Oil pressure signal indicates oil pressure below the very low oil pressure engine protection limit.	Progressive power derate with increasing time from alert. If engine protection shutdown feature is enabled, engine will shut down 30 seconds after red lamp starts flashing.
418	Water has been detected in the fuel filter.	Possible white smoke, loss of power, or hard starting.
419	An error in the intake manifold pressure sensor signal was detected by the ECM.	Engine is derated to no air setting.
422	Voltage detected simultaneously on both the coolant level high and low signal circuits OR no voltage detected on both circuits.	No engine protection for coolant level.
426	Communication between the ECM and the J1939 data link has been lost.	None on performance. J1939 devices may not operate.
428	High voltage detected at water-in-fuel sensor.	None on performance.
429	Low voltage detected at water-in-fuel sensor.	None on performance.
431	Voltage detected simultaneously on both the idle validation off-idle and on-idle circuits.	None on performance.
432	Voltage detected at idle validation on-idle circuit when voltage at throttle position circuit indicates the pedal is not at idle OR voltage detected at idle validation off-idle circuit when voltage at throttle position circuit indicates the pedal is at idle.	Engine will only idle.
433	Voltage signal at intake manifold pressure circuit indicates high intake manifold pressure but other engine characteristics indicate intake manifold pressure must be low.	Derate to no air setting.
434	Supply voltage to the ECM fell below 6.2 VDC for a fraction of a second OR the ECM was not allowed to power down correctly (retain battery voltage for 30 seconds after key off).	Possible no noticeable performance effects OR possibility of engine dying OR hard starting. Fault information, trip information and maintenance monitor data may be inaccurate.
435	An error in the oil pressure sensor signal was detected by the ECM.	None on performance. No engine protection for oil pressure.
441	Battery voltage below normal operating level.	Possible no noticeable performance effects OR possibility of rough idle.
442	Battery voltage below normal operating level.	None on performance.
443	Low voltage detected on the ECM voltage supply line to the throttle(s) (VTP supply).	Engine will only idle.
489	Auxiliary speed frequency on input pin indicated that the frequency is below a calibration dependent threshold.	Engine will only idle.
527	Less than 17.0 VDC detected at the dual output A signal pin of the 31-pin machine connector.	No action taken by the ECM.
528	Less than 17.0 VDC detected at the dual output B signal pin of the 31-pin machine connector.	No action taken by the ECM.
529	Less than 17.0 VDC detected at the dual output B signal pin at the ECM.	No action taken by the ECM.
551	No voltage detected simultaneously on both the idle validation off-idle and on-idle circuits.	Engine will only idle.
581	High voltage detected at the fuel inlet restriction sensor signal pin.	Fuel inlet restriction monitor deactivated.

Fault code No.	Reason	Effect(only when fault code is active)
582	Low voltage detected at the fuel inlet restriction sensor signal pin	Fuel inlet restriction monitor deactivated.
583	Restriction has been detected at the fuel pump inlet.	Fuel inlet restriction monitor warning is set.
596	High battery voltage detected by the battery voltage monitor feature.	Yellow lamp will be lit until high battery voltage condition is corrected.
597	ICON™ has restarted the engine three times within three hours due to low battery voltage (automotive only) OR low battery voltage detected by the battery voltage monitor feature.	Yellow lamp will be lit until low battery voltage condition is corrected. The ECM may increase idle speed and deactivate idle decrement switch if idle speedup is enabled. The engine will run continuously if ICON™ is active (automotive only).
598	Very low battery voltage detected by the battery voltage monitor feature.	Red lamp lit until very low battery voltage condition is corrected.
611	Engine shutdown by operator before proper engine cool down resulting in filtered load factor above maximum shutdown threshold.	No action taken by the ECM.
951	A power imbalance between cylinders was detected by the ECM.	Engine may have rough idle or misfire.

GROUP 10 ENGINE CONTROL SYSTEM

1. MCU (Machine control unit) AND ECM (Electronic control module)

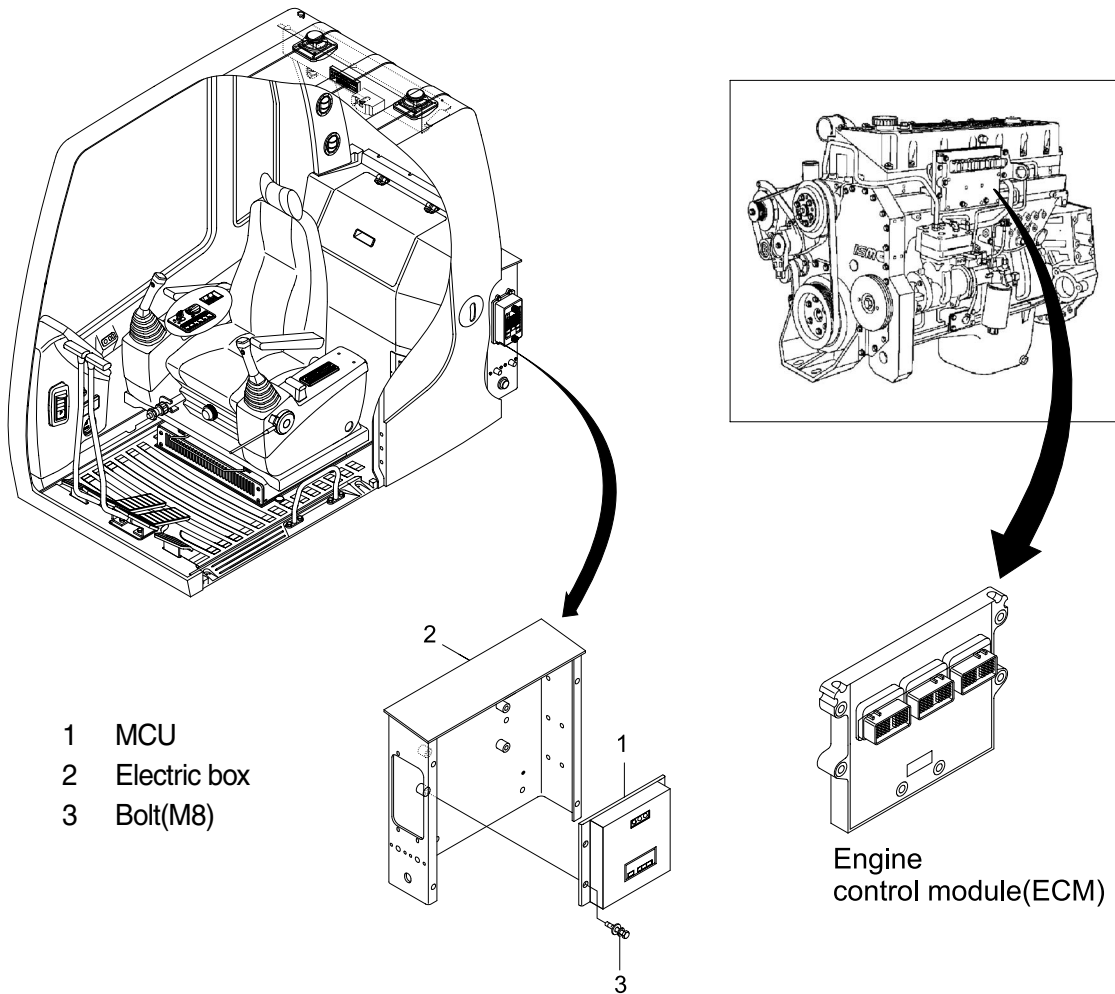

45075MS06

2. MCU ASSEMBLY

- 1) To match the pump absorption torque with the engine torque, MCU varies EPPR valve output pressure, which control pump discharge amount whenever feedbacked engine speed drops under the reference rpm of each mode set.
- 2) Three LED lamps on the MCU display as below.

LED lamp	Trouble	Service
G is turned ON	Normal	-
G and R are turned ON	Trouble on MCU	· Change the MCU
G and Y are turned ON	Trouble on serial communication line	· Check if serial communication lines between controller and cluster are disconnected
Three LED are turned OFF	Trouble on MCU power	· Check if the input power wire (24 V, GND) of controller is disconnected · Check the fuse

G : green, R : red, Y : yellow

3. EXCHANGE METHOD OF THE ROM

- 1) Disassemble the ash tray(2).
- 2) Disassemble the wiper motor cover(3).
- 3) Disassemble the cluster(1).

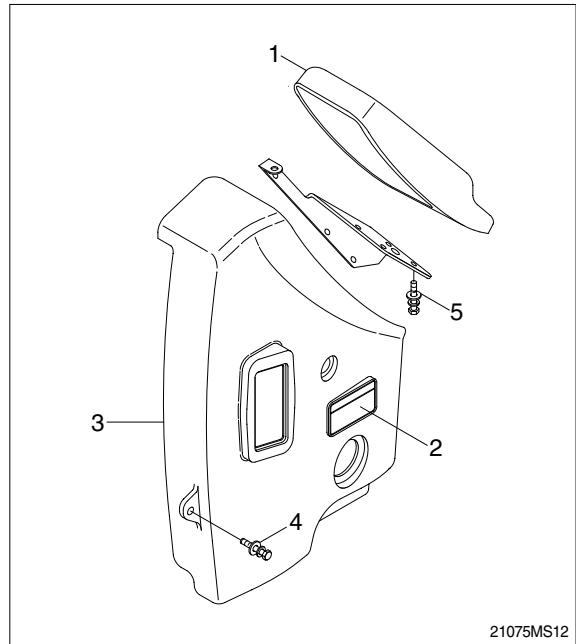

- 4) Loosen the screws(6EA) located back of the cluster.
- 5) Then you can open the upper case of the cluster easily.

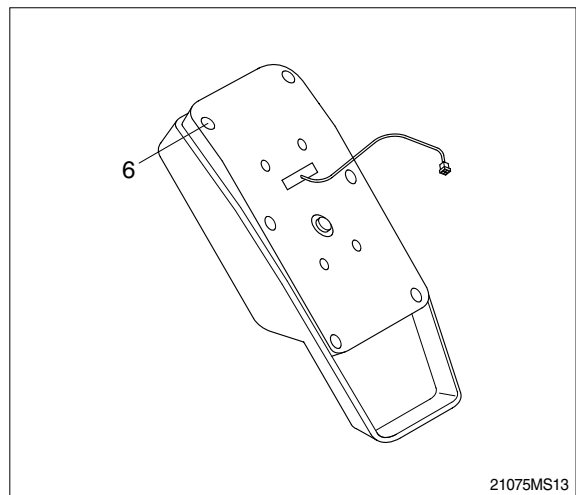

- 6) Install the new ROM.(Be careful of direction and assmelbe the cluster in the reverse order to removal).

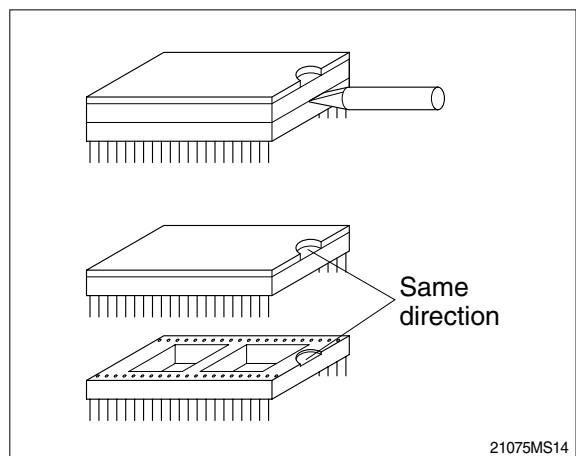

GROUP 11 EPPR VALVE

1. COMPOSITION OF EPPR VALVE

EPPR(Electro Proportional Pressure Reducing) valve consists of electro magnet and spool valve installed at main hydraulic pump.

1) ELECTRO MAGNET VALVE

Receive electric current from MCU and move the spool proportionally according to the specific amount of electric current value.

2) SPOOL VALVE

Is the two way direction control valve for pilot pressure to reduce hydraulic pump flow.

When the electro magnet valve is activated, pilot pressure enters into flow regulator of hydraulic pump. So, pump flow decreases to prevent engine stall.

3) PRESSURE AND ELECTRIC CURRENT VALUE FOR EACH MODE

Mode		Pressure		Electric current (mA)	Engine rpm (At accel dial 10)
		kgf/cm ²	psi		
Standard (Ver : 1.x)	M	12 ± 3	171 ± 40	360 ± 30	1750 ± 50
	H	12 ± 3	171 ± 40	360 ± 30	1700 ± 50
	S	12 ± 3	171 ± 40	360 ± 30	1650 ± 50

2. HOW TO SWITCH THE VERSION(3.1↔ 4.1) ON THE CLUSTER

You can switch the EPPR valve pressure set by selecting the version(3.1 ↔ 4.1).

- Dual mode
 - Changing the MCU mode



2. OPERATING PRINCIPLE

1) STRUCTURE

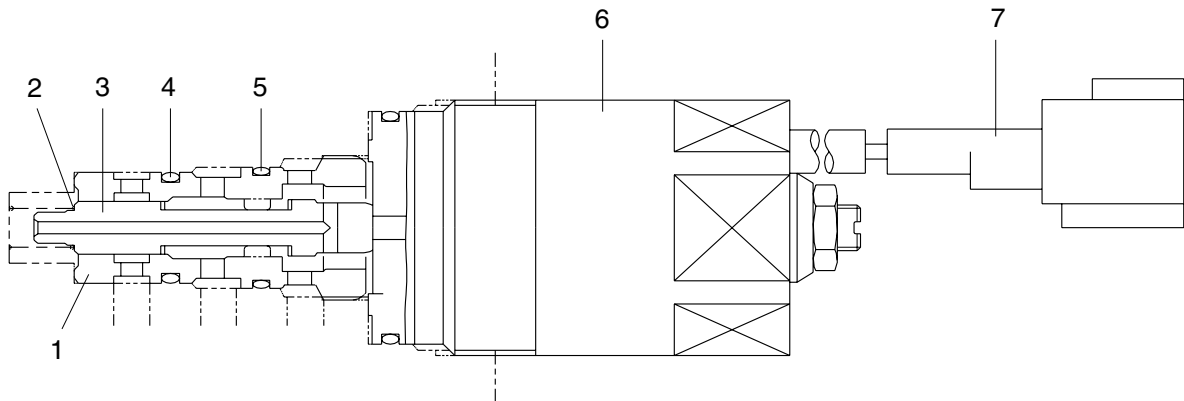

5-22(1) 210-7

- 1 Sleeve
- 2 Spring
- 3 Spool

- 4 O-ring
- 5 O-ring

- 6 Solenoid valve
- 7 Connector

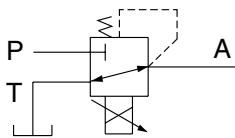

5-22A (210-7)

P Pilot oil supply line(Pilot pressure)

T Return to tank

A Secondary pressure to flow regulator at hydraulic pump

2) AT H MODE

Pressure line is blocked and A oil returns to tank.

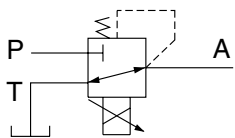

5-22B (210-7)

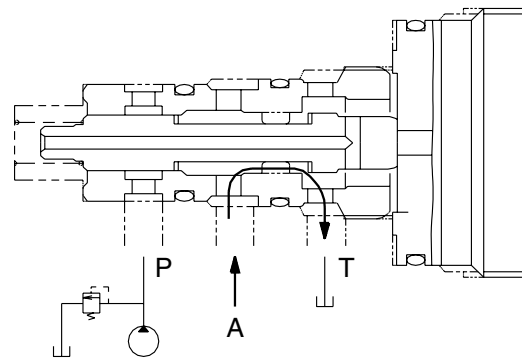

3) AT S MODE

Secondary pressure enters into A.

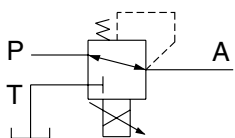

5-22C (210-7)

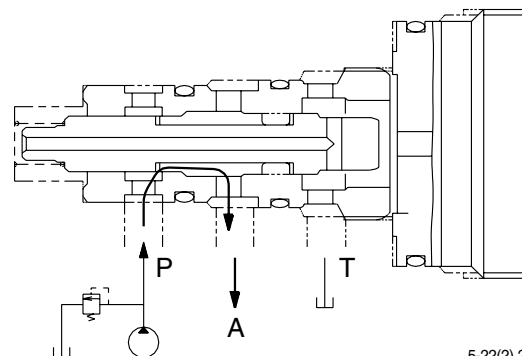

5-22(2) 210-7

3. EPPR VALVE CHECK PROCEDURE

1) CHECK ELECTRIC VALUE AT EPPR VALVE

- (1) Start engine.
- (2) Set S-mode and cancel auto decel mode.
- (3) Position the accel dial at 10.
- (4) If tachometer show approx 1650 ± 50 rpm, disconnect one wire harness from EPPR valve.
- (5) Install multimeter as figure.
- (6) Check electric current at bucket circuit relief position.

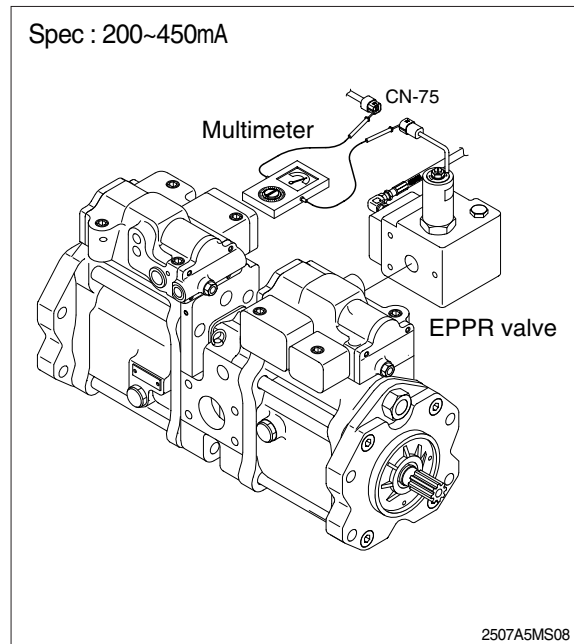

2) CHECK PRESSURE AT EPPR VALVE

- (1) Remove plug and connect pressure gauge as figure.
 - Gauge capacity : 0 to 40-50kgf/cm²
(0 to 580-725psi)
- (2) Start engine.
- (3) Set S-mode and cancel auto decel mode.
- (4) Position the accel dial at 10.
- (5) If tachometer show approx 1650 ± 50 rpm, check pressure at relief position of bucket circuit by operating bucket control lever.
- (6) If pressure is not correct, adjust it.
- (7) After adjust, test the machine.

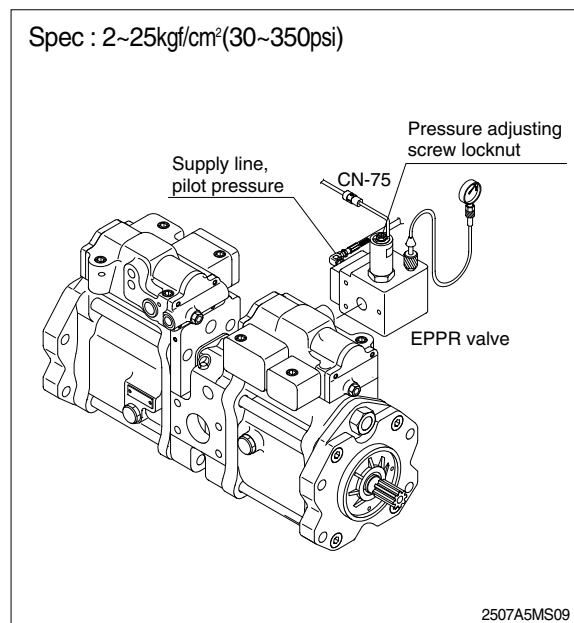

GROUP 11 EPPR VALVE

1. COMPOSITION OF EPPR VALVE

EPPR(Electro Proportional Pressure Reducing) valve consists of electro magnet and spool valve installed at main hydraulic pump.

1) ELECTRO MAGNET VALVE

Receive electric current from MCU and move the spool proportionally according to the specific amount of electric current value.

2) SPOOL VALVE

Is the two way direction control valve for pilot pressure to reduce hydraulic pump flow.

When the electro magnet valve is activated, pilot pressure enters into flow regulator of hydraulic pump. So, pump flow decreases to prevent engine stall.

3) PRESSURE AND ELECTRIC CURRENT VALUE FOR EACH MODE

Mode		Pressure		Electric current (mA)	Engine rpm (At accel dial 10)
		kgf/cm ²	psi		
Standard (Ver : 1.x)	M	12 ± 3	171 ± 40	360 ± 30	1750 ± 50
	H	12 ± 3	171 ± 40	360 ± 30	1700 ± 50
	S	12 ± 3	171 ± 40	360 ± 30	1650 ± 50

2. HOW TO SWITCH THE VERSION(3.1↔ 4.1) ON THE CLUSTER

You can switch the EPPR valve pressure set by selecting the version(3.1 ↔ 4.1).

- Dual mode
 - Changing the MCU mode



2. OPERATING PRINCIPLE

1) STRUCTURE

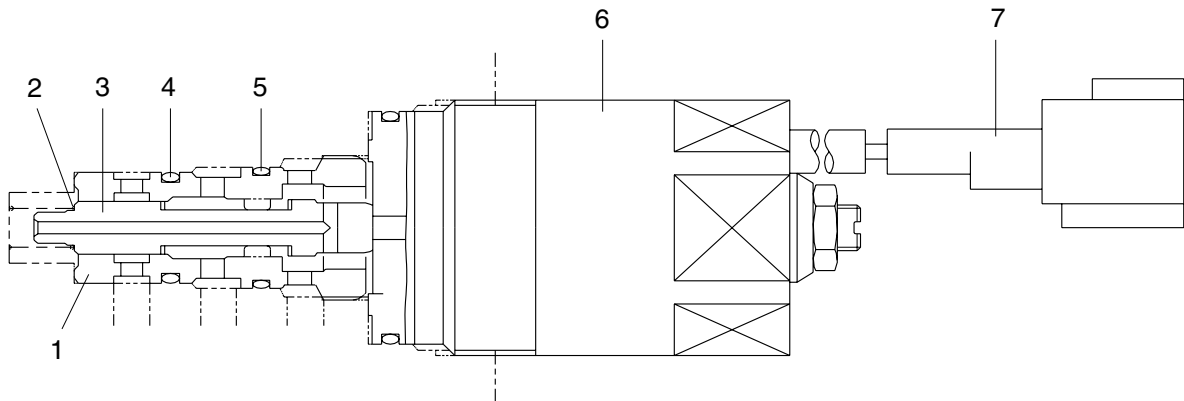

5-22(1) 210-7

- 1 Sleeve
- 2 Spring
- 3 Spool

- 4 O-ring
- 5 O-ring

- 6 Solenoid valve
- 7 Connector

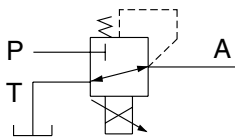

5-22A (210-7)

P Pilot oil supply line(Pilot pressure)

T Return to tank

A Secondary pressure to flow regulator at hydraulic pump

2) AT H MODE

Pressure line is blocked and A oil returns to tank.

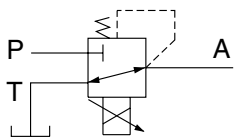

5-22B (210-7)

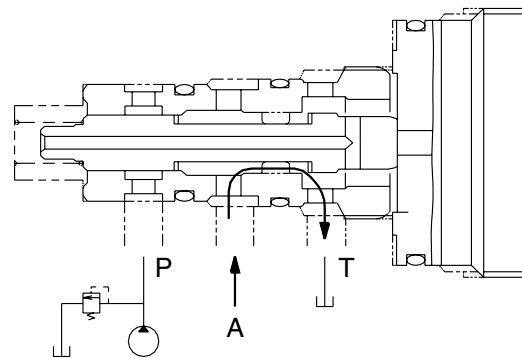

3) AT S MODE

Secondary pressure enters into A.

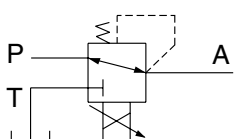

5-22C (210-7)

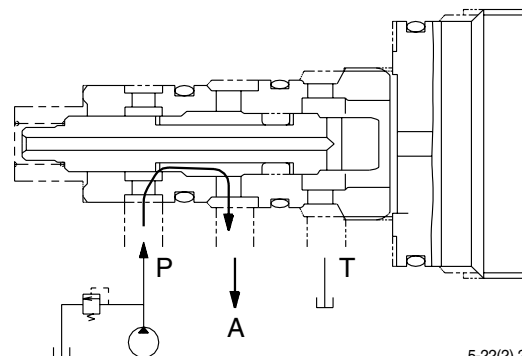

5-22(2) 210-7

3. EPPR VALVE CHECK PROCEDURE

1) CHECK ELECTRIC VALUE AT EPPR VALVE

- (1) Start engine.
- (2) Set S-mode and cancel auto decel mode.
- (3) Position the accel dial at 10.
- (4) If tachometer show approx 1650 ± 50 rpm, disconnect one wire harness from EPPR valve.
- (5) Install multimeter as figure.
- (6) Check electric current at bucket circuit relief position.

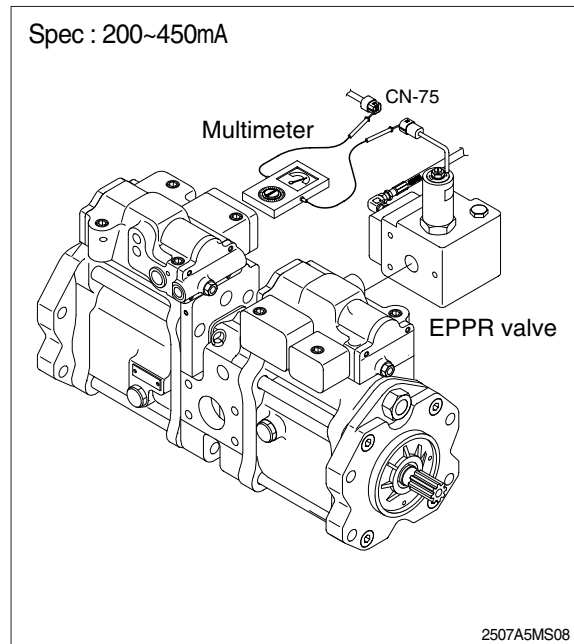

2) CHECK PRESSURE AT EPPR VALVE

- (1) Remove plug and connect pressure gauge as figure.
 - Gauge capacity : 0 to 40-50kgf/cm²
(0 to 580-725psi)
- (2) Start engine.
- (3) Set S-mode and cancel auto decel mode.
- (4) Position the accel dial at 10.
- (5) If tachometer show approx 1650 ± 50 rpm, check pressure at relief position of bucket circuit by operating bucket control lever.
- (6) If pressure is not correct, adjust it.
- (7) After adjust, test the machine.

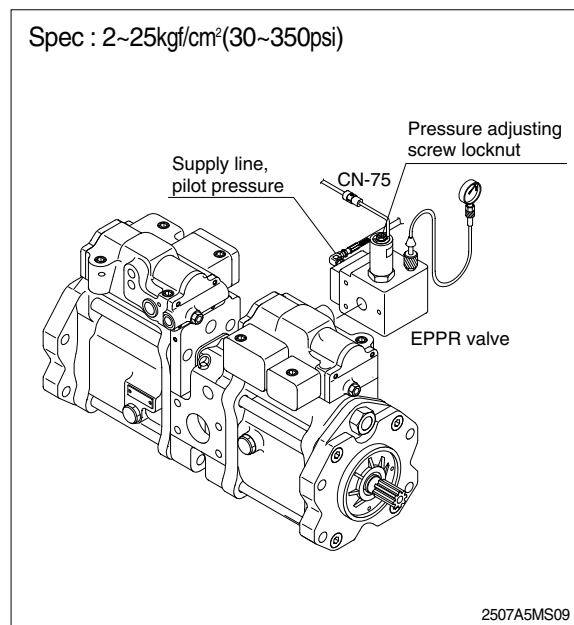

GROUP 12 MONITORING SYSTEM

1. OUTLINE

Monitoring system consists of the monitor part and switch part.

The monitor part gives warnings when any abnormality occurs in the machine and informs the condition of the machine.

Various select switches are built into the monitor panel, which act as the control portion of the machine control system.

2. CLUSTER

1) MONITOR PANEL

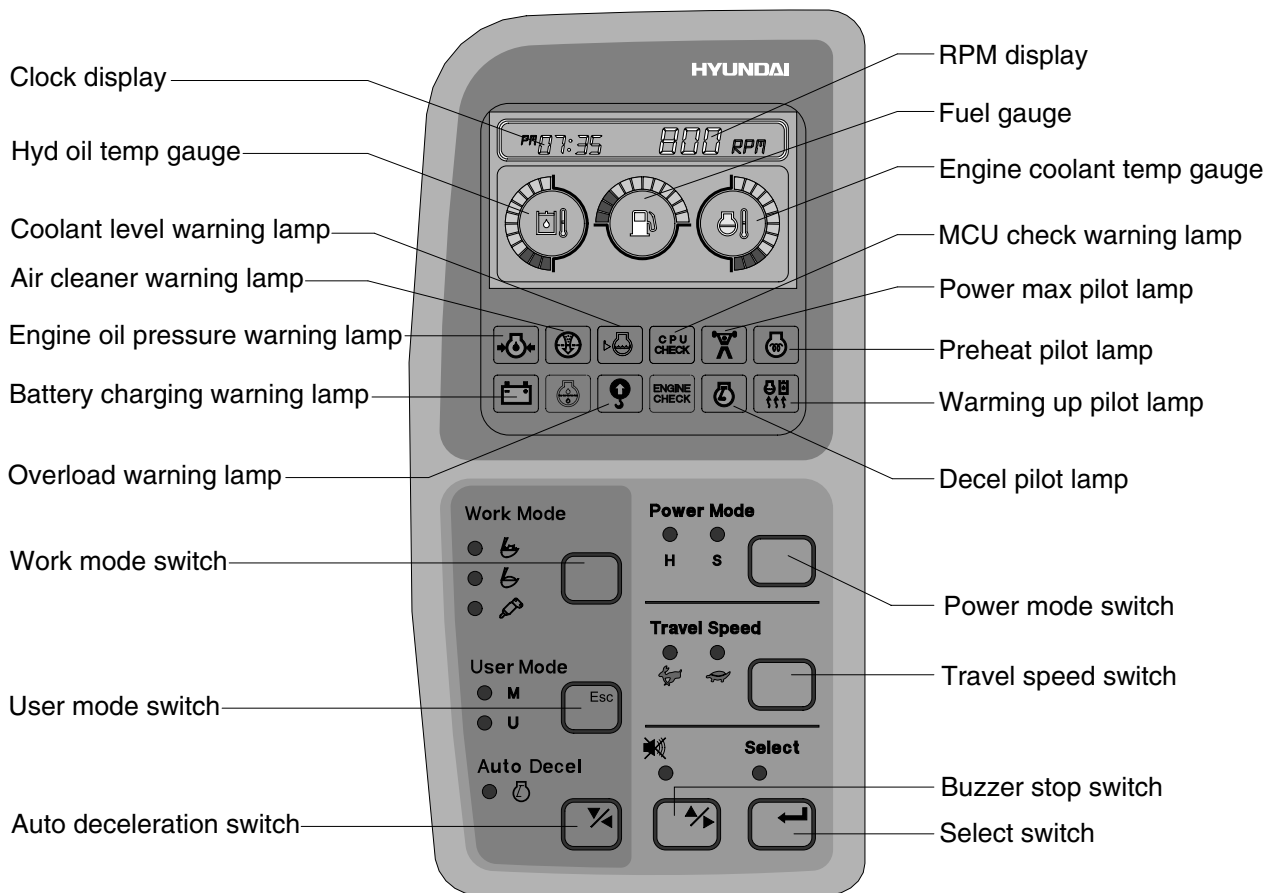

30075MS01

2) CLUSTER CHECK PROCEDURE

(1) Start key : ON

- ① Check monitor initial 5 seconds
 - a. All lamps light up.
 - b. Buzzer sound.
- ② Check monitor after 5 seconds : Indicate cluster version and machine condition
 - a. Cluster program version : 「1.00」 ← Indicates program version 「1.00」 for 5 seconds.
 - b. Tachometer : 0rpm
 - c. Fuel gauge : All light up below appropriate level
 - d. Hydraulic temperature : All light up below appropriate level
 - e. Engine coolant temperature gauge : All light up below appropriate level
 - f. Warning lamp
 - ※ During start key **ON** the engine oil pressure lamp and battery charging lamp go on, but it is not abnormal.
 - ※ When engine coolant temperature below 30°C, the warming up lamp lights up.
- ③ Indicating lamp state
 - a. Work mode selection : General work
 - b. Power mode selection : S mode
 - c. User mode selection : No LED ON
 - d. Auto decel LED : ON
 - e. Travel speed pilot lamp : Low(Turtle)

(2) Start of engine

- ① Check machine condition
 - a. Tachometer indicates at present rpm
 - b. Gauge and warning lamp : Indicate at present condition.
 - ※ When normal condition : All warning lamp OFF
 - c. Work mode selection : General work
 - d. Power mode selection : S mode
 - e. User mode selection : No LED ON
 - f. Auto decel LED : ON
 - g. Travel speed pilot lamp : Low(Turtle)
- ② When warming up operation
 - a. Warming up lamp : ON
 - b. 10 seconds after engine started, engine speed increases to 1000rpm(Auto decel LED : ON)
 - ※ Others same as above ①.
- ③ When abnormal condition
 - a. The lamp lights up and the buzzer sounds.
 - b. If **BUZZER STOP** switch is pressed, buzzer sound is canceled but the lamp light up until normal condition.

3. CLUSTER CONNECTOR

No.	Signal	Input / Output
1	Power IG(24V)	Input(20~32V)
2	GND	Input(0V)
3	Serial-(RX)	Input(Vpp=12V)
4	Serial+(TX)	Output(Vpp=4V)

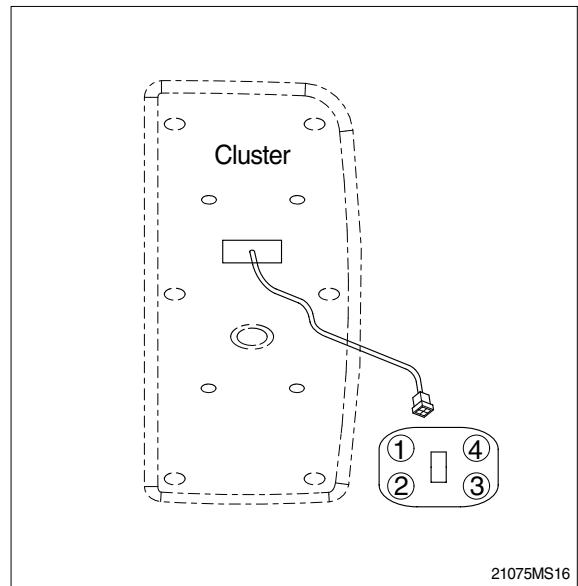

4. CLUSTER FUNCTION

1) LCD main operation display

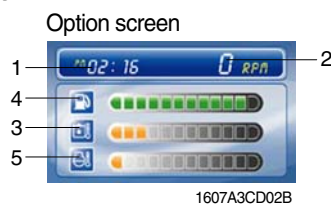
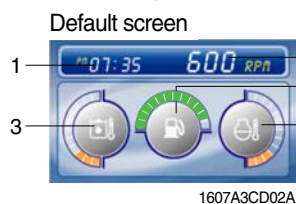

- 1 Time display
- 2 RPM display
- 3 Hydraulic oil temperature gauge
- 4 Fuel level gauge
- 5 Engine coolant temperature gauge

(1) Time display



- ① This displays the current time.

※ Refer to the page 5-45 to set time for details.

(2) RPM display



- ① This displays the engine rpm.

(3) Hydraulic oil temperature gauge



- ① This gauge indicates the temperature of hydraulic oil in 12 step gauge.

- 1st step : Below 30°C(86°F)
- 2nd~10th step : 30-105 °C(86-221°F)
- 11th~12th step : Above 105°C(221°F)

- ② The gauge between 2nd and 10th steps illuminates when operating.
- ③ Keep idling engine at low speed until the gauge between 2nd and 10th steps illuminates, before operation of machine.
- ④ When the gauge of 11th and 12th steps illuminates, reduce the load on the system. If the gauge stays in the 11th~12th steps, stop the machine and check the cause of the problem.

(4) Fuel level gauge

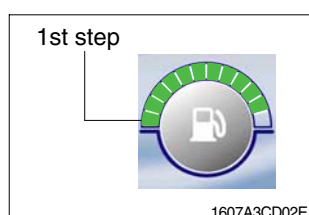

- ① This gauge indicates the amount of fuel in the fuel tank.

- ② Fill the fuel when the 1st step or fuel icon blinks in red.

※ If the gauge illuminates the 1st step or fuel icon blinks in red even though the machine is on the normal condition, check the electric device as that can be caused by the poor connection of electricity or sensor.

(5) Engine coolant temperature gauge

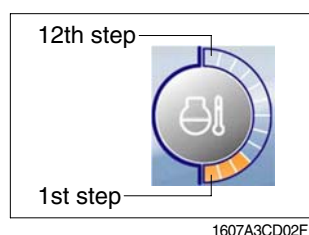

- ① This gauge indicates the temperature of coolant in 12 step gauge.

- 1st step : Below 30°C(86°F)
- 2nd~10th step : 30-105 °C(86-221°F)
- 11th~12th step : Above 105°C(221°F)

- ② The gauge between 2nd and 10th steps illuminates when operating.
- ③ Keep idling engine at low speed until the gauge between 2nd and 10th steps illuminates, before operation of machine.
- ④ When the gauge of 11th and 12th steps illuminates, turn OFF the engine, check the radiator and engine.

3) Warning of main operation screen

(1) Warning display

① Engine coolant temperature



- This lamp blinks and the buzzer sounds when the temperature of coolant is over the normal temperature 105°C (221°F) .
- Check the cooling system when the lamp blinks.

② Fuel level



- This lamp blinks and the buzzer sounds when the level of fuel is below 68 l (18 U.S. gal).
- Fill the fuel immediately when the lamp blinks.

③ Hydraulic oil temperature



- This warning lamp operates and the buzzer sounds when the temperature of hydraulic oil is over 105 °C (221 °F) .
- Check the hydraulic oil level when the lamp blinks.
- Check for debris between oil cooler and radiator.

④ All gauge



- This lamp blinks and the buzzer sounds when the all gauge is abnormal.
- Check the each system when the lamp blinks.

⑤ Communication error



- Communication problem between MCU controller and cluster makes the lamp blinks and the buzzer sounds.
- Check if any fuse for MCU burnt off.
If not check the communication line between them.





(2) Pop-up icon display

No	Switch	Selected mode	Display
1	Work mode switch	General work mode	
		Heavy duty work mode	
		Breaker operation mode	
2	Power mode switch	High power work mode	
		Standard power work mode	

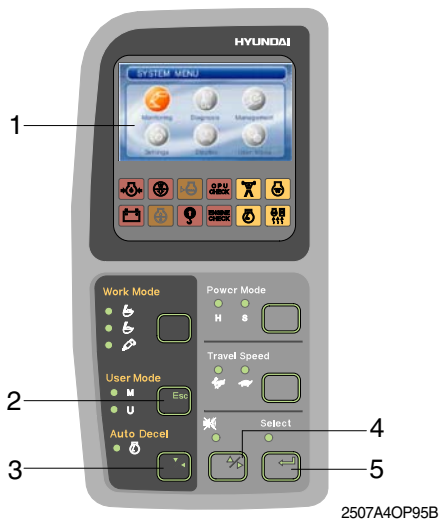
No	Switch	Selected mode	Display
3	Auto deceleration switch	Light ON	
		Light OFF	
4	Travel speed control switch	Low speed	
		High speed	



4) LCD

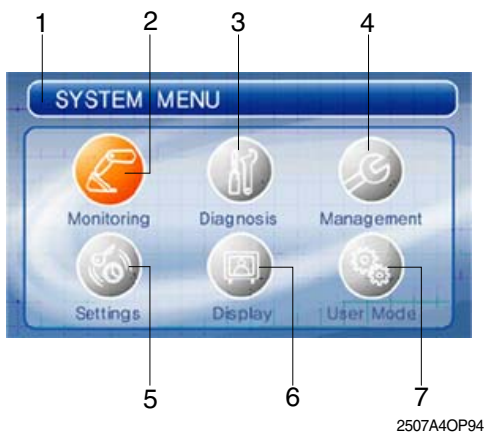

- 1  : LCD
- 2  : Escape,
Return to the previous menu
- 3  : Down/Left Direction
- 4  : Up/Right Direction
- 5  : Select(Enter)
Activate the currently chosen item

(1) Main menu



- 1  : Menu information
- 2  : Monitoring
- Equipment, Switch, Output
- 3  : Diagnosis
- Current error, Recorded error
- 4  : Maintenance
- 5  : Settings
- Time set, Dual mode
- System lock(Reserved)
- 6  : Display
- Operation skin, Brightness, Language
- 7  : User mode

(2) Display map

① Monitoring

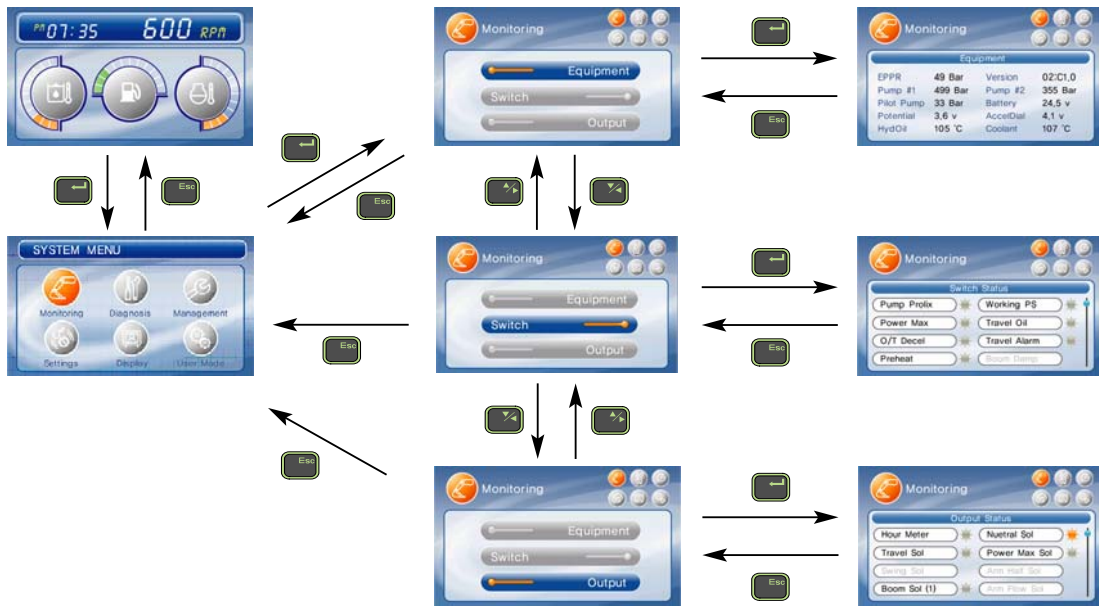

② Diagnosis

- If there are more than 2 error codes, each one can be displayed by pressing or switch respectively.

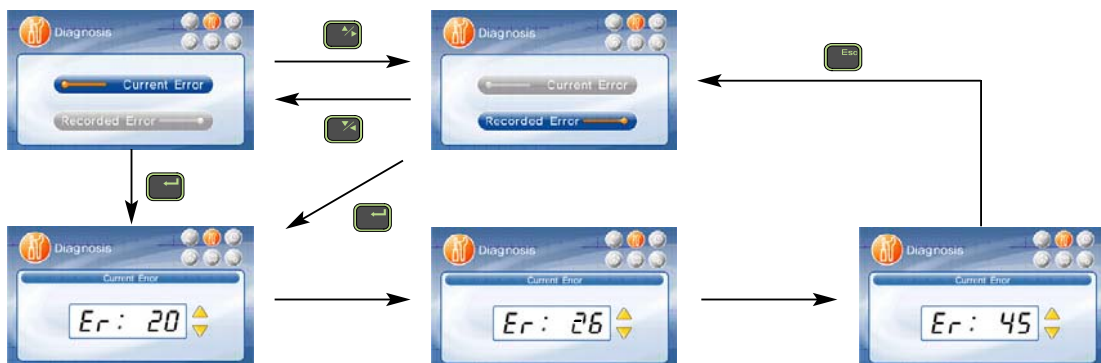

③ Maintenance

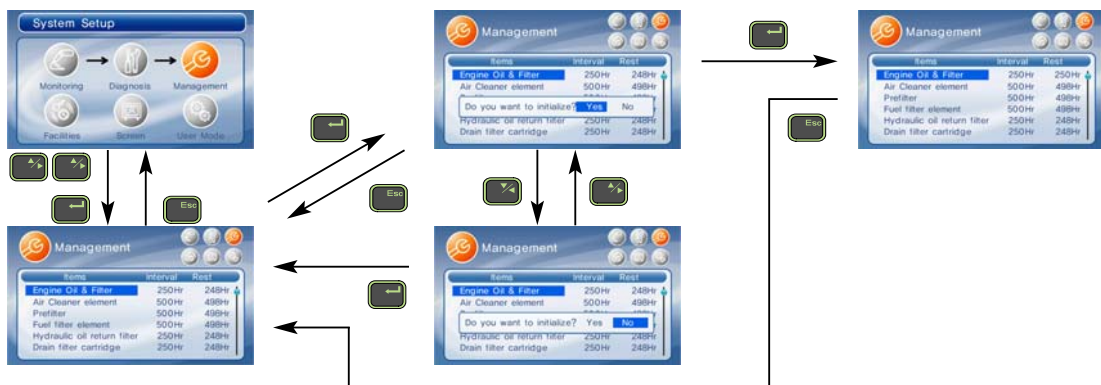

④ Setting

a. Time set



b. System lock - Reserved

c. Dual mode
- Changing the MCU mode



⑤ Display

a. Operation skin



b. Brightness

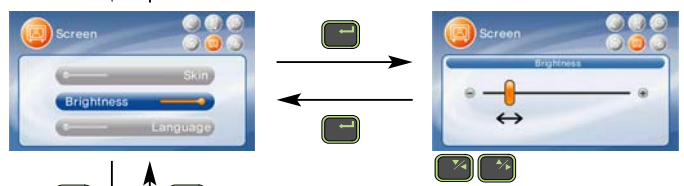

c. Language

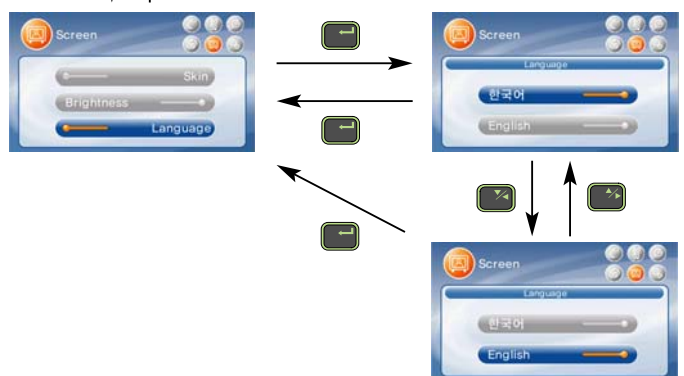

⑥ User mode

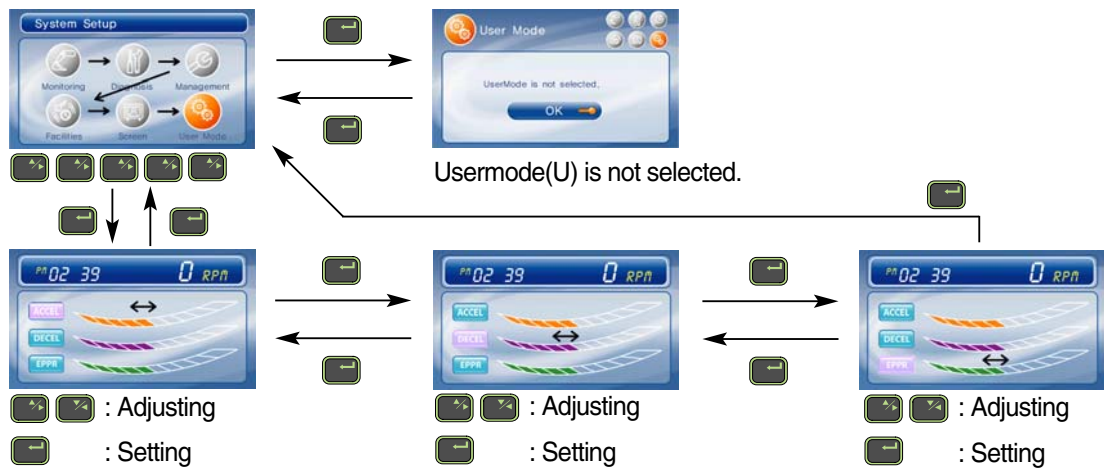

5) Warning and pilot lamp

(1) Engine oil pressure warning lamp

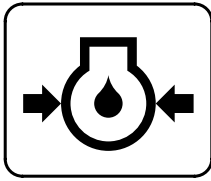

21073CD07

- ① This lamp blinks and the buzzer sounds after starting the engine because of the low oil pressure.
- ② If the lamp blinks during engine operation, shut OFF engine immediately. Check oil level.

(2) Air cleaner warning lamp

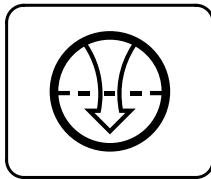

21073CD08

- ① This lamp blinks and the buzzer sounds when the filter of air cleaner is clogged.
- ② Check the filter and clean or replace it.

(3) MCU check warning lamp

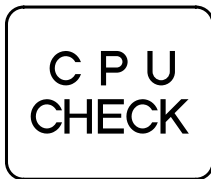

21073CD10

- ① If any fault code is received from MCU, this lamp blinks and the buzzer sounds.
- ② Check the communication line between MCU and cluster.

(4) Battery charging warning lamp

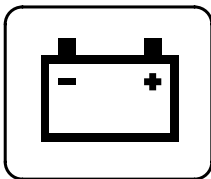

21073CD13

- ① This lamp blinks and the buzzer sounds when the starting switch is ON, it is turned OFF after starting the engine.
- ② Check the battery charging circuit when this lamp blinks during engine operation.

(5) Overload warning lamp (Option)

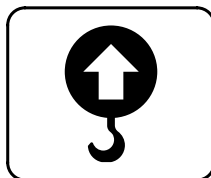

21073CD15

- ① When the machine is overload, the overload warning lamp blinks during the overload switch is ON.

(6) Power max pilot lamp

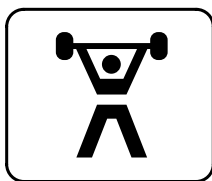

21073CD11

- ① The lamp will be ON when pushing power max switch on the LH RCV lever.

(7) Decel pilot lamp



21073CD17

- ① Operating auto decel or one touch decel makes the lamp ON.
- ② The lamp will be ON when pushing one touch decel switch on the LH RCV lever.

(8) Warming up pilot lamp

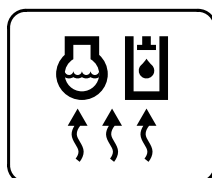

21073CD18

- ① This lamp is turned ON when the coolant temperature is below 30°C (86 °F).
- ② The automatic warming up is cancelled when the engine coolant temperature is above 30 °C, or when 10 minutes have passed since starting.

(9) Preheat pilot lamp

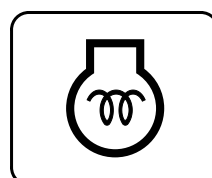



21073CD12

- ① Turning the start key switch ON position starts preheating in cold weather.
- ② Start the engine as this lamp is OFF.

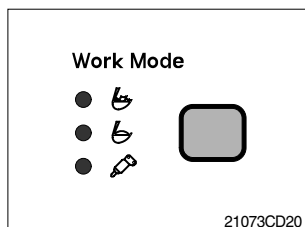
(10) Work mode switch



- ① This switch is to select the machine operation mode, which shifts from general operation mode to heavy operation mode and breaker mode in a row by pressing the switch.
 -  : Heavy duty work mode
 -  : General work mode
 -  : Breaker operation mode

※ Refer to the page 5-4 for details.

(11) User mode switch

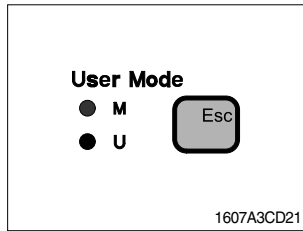

- ① This switch is to select the maximum power or user mode.
 - M : Maximum power
 - U : Memorizing operators preferable power setting.
- ※ Refer to the page 5-5 for details.

(12) Auto deceleration switch

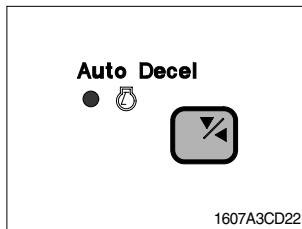

- ① This switch is used to actuate or cancel the auto deceleration function.
- ② When the switch actuated and all control levers and pedals are at neutral position, engine speed will be lowered automatically to save fuel consumption.
 - Light ON : Auto deceleration function is selected.
 - Light OFF : a. Auto deceleration function is cancelled so that the engine speed increased to previous setting value.
b. One touch decel function is available.

(13) Power mode switch

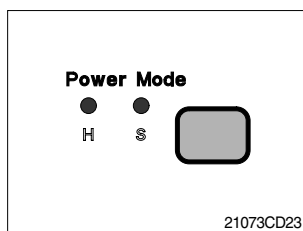

- ① The lamp of selected mode is turned ON by pressing the switch().
 - H : High power work.
 - S : Standard power work.

(14) Travel speed control switch

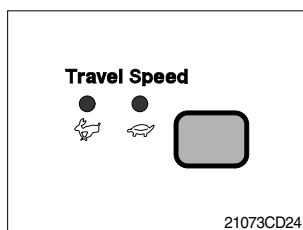

- ① This switch is to control the travel speed which is changed to high speed(Rabbit mark) by pressing the switch and low speed(Turtle mark) by pressing it again.

(15) Buzzer stop switch

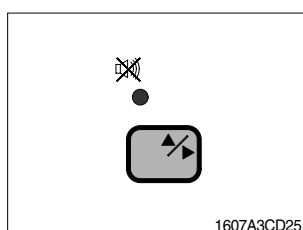

- ① When the starting switch is turned ON first, normally the alarm buzzer sounds for 2 seconds during lamp check operation.
- ② The red lamp lights ON and the buzzer sounds when the machine has a problem.
In this case, press this switch and buzzer stops, but the red lamp lights until the problem is cleared.

(16) Select switch

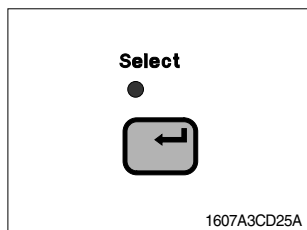

① This switch is used to enter main menu and sub menu of LCD.

※ **Refer to the page 5-30 for details.**