

GROUP 4 MAIN CONTROL VALVE

1. REMOVAL AND INSTALL

1) REMOVAL

- (1) Lower the work equipment to the ground and stop the engine.
- (2) Operate the control levers and pedals several times to release the remaining pressure in the hydraulic piping.
- (3) Loosen the breather slowly to release the pressure inside the hydraulic tank.
- ▲ **Escaping fluid under pressure can penetrate the skin causing serious injury.**
 - ※ When pipes and hoses are disconnected, the oil inside the piping will flow out, so catch it in oil pan.
- (4) Remove bolts and disconnect pipe.
- (5) Disconnect pilot line hoses.
- (6) Disconnect pilot piping.
- (7) Sling the control valve assembly and remove the control valve mounting bolt.
 - Weight : 420kg(930lb)
- (8) Remove the control valve assembly.
When removing the control valve assembly, check that all the piping have been disconnected.

2) INSTALL

- (1) Carry out installation in the reverse order to removal.
- (2) Bleed the air from below items.
 - ① Cylinder(Boom, arm, bucket)
 - ② Swing motor
 - ③ Travel motor
 - ※ See each item removal and install.
- (3) Confirm the hydraulic oil level and recheck the hydraulic oil leak or not.

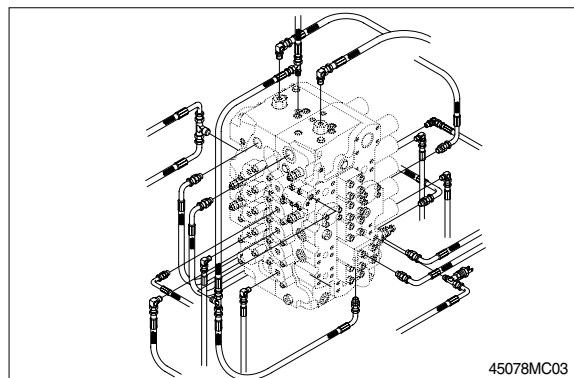
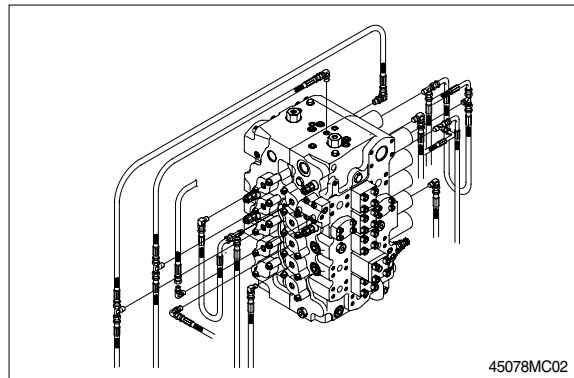
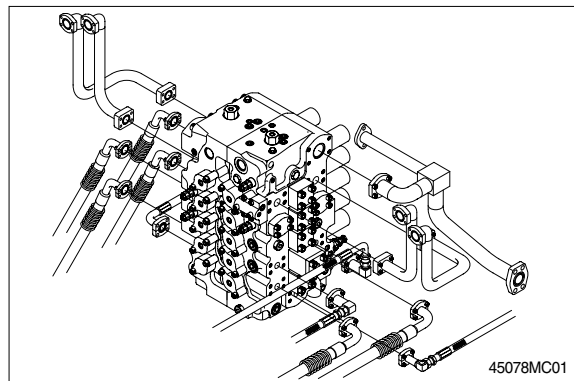

2. STRUCTURE(1/3)

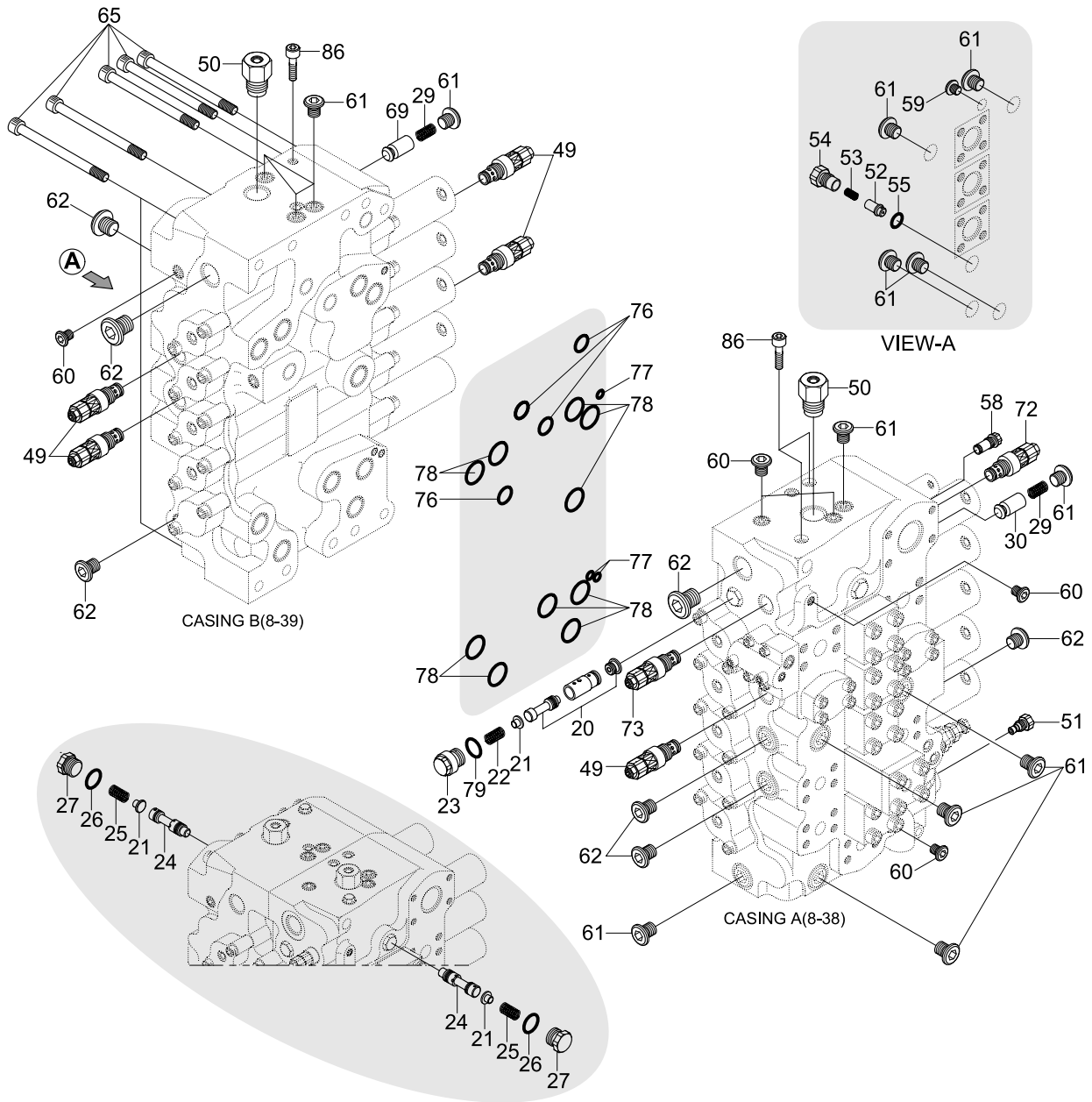

20	Spool assy	50	Relief valve assy	62	Plug assy
21	Spring seat	51	Plug assy	65	Bolt
22	Spring	52	Poppet	69	Poppet
23	Plug	53	Spring	72	Relief valve kit
24	Spool assy	54	Plug	73	Relief valve kit
25	Spring	55	O-ring	76	O-ring
26	O-ring	58	Plug assy	77	O-ring
27	Plug	59	Plug assy	78	O-ring
29	Spring	60	Plug assy	79	O-ring
30	Poppet	61	Plug assy	86	Socket head bolt
49	Relief valve kit				

45078MC04

STRUCTURE(2/3)

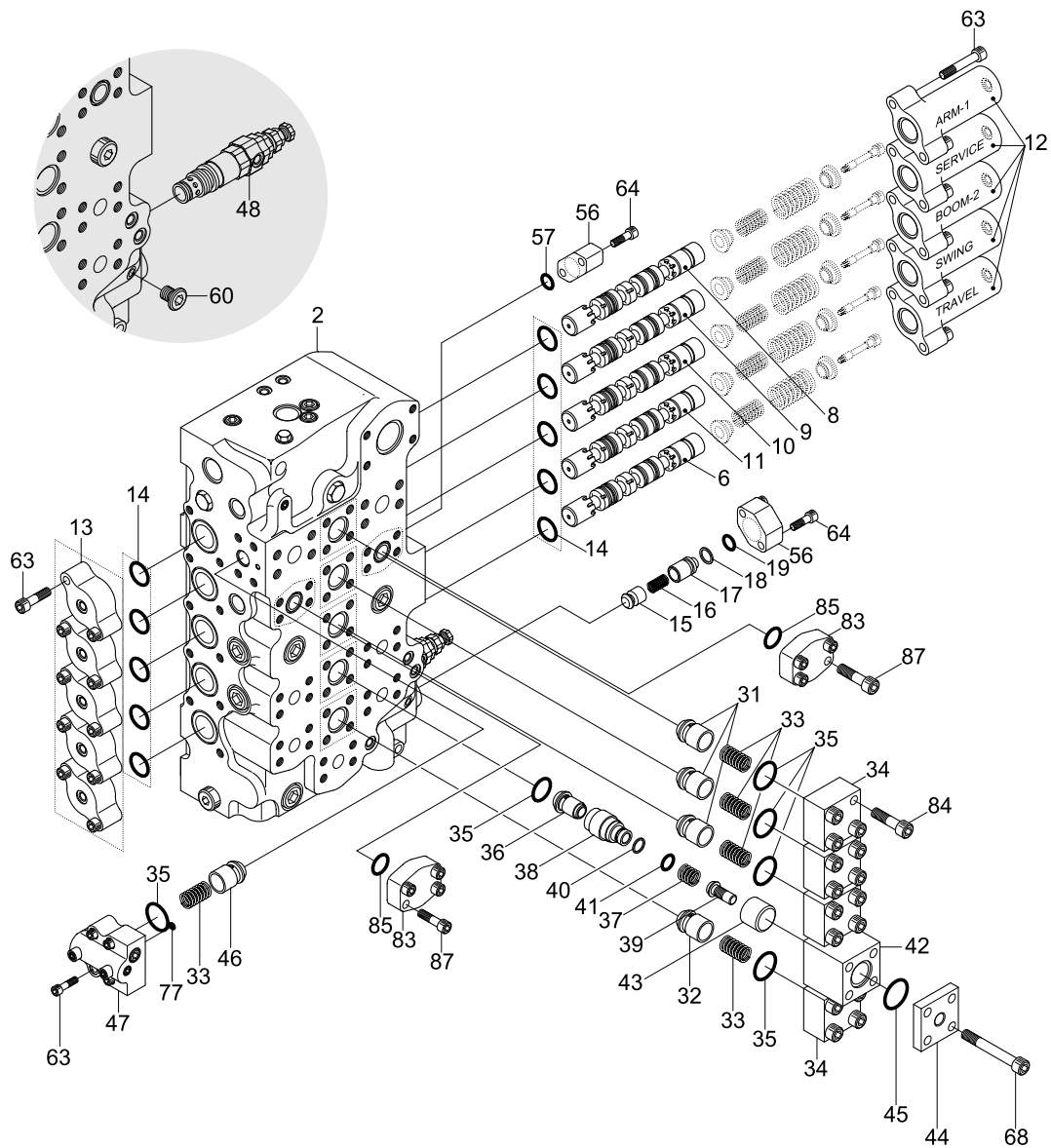

45078MC05

- | | | | | | |
|----|--------------|----|--------------|----|-------------------|
| 2 | Housing | 32 | Poppet | 46 | Poppet |
| 6 | Spool assy | 33 | Spring | 47 | Body assy |
| 8 | Spool assy | 34 | Flange | 48 | Relief valve assy |
| 9 | Spool assy | 35 | O-ring | 56 | Flange |
| 10 | Spool assy | 36 | Poppet assy | 57 | O-ring |
| 11 | Spool assy | 37 | Spring | 60 | Plug assy |
| 12 | Cap | 38 | Sleeve | 63 | Bolt |
| 13 | Cap | 39 | Piston | 64 | Bolt |
| 14 | O-ring | 40 | O-ring | 68 | Bolt |
| 15 | Poppet | 41 | Back up ring | 77 | O-ring |
| 16 | Spring | 42 | Body | 83 | Flange |
| 17 | Spacer | 43 | Piston | 84 | Bolt |
| 18 | O-ring | 44 | Flange | 85 | O-ring |
| 19 | Back up ring | 45 | O-ring | 87 | Bolt |
| 31 | Poppet | | | | |

STRUCTURE(3/3)

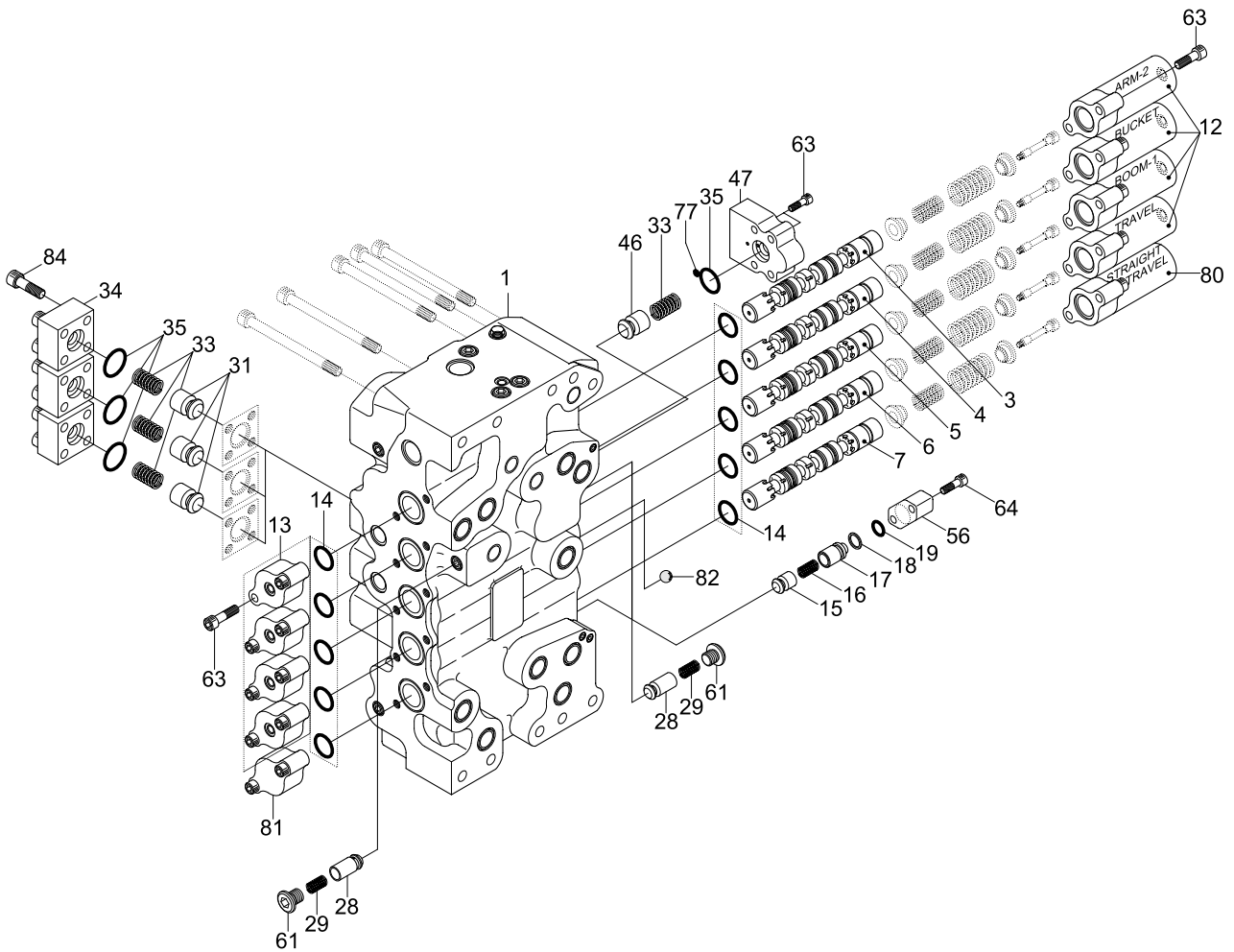

45078MC06

- | | | | | | |
|----|------------|----|--------------|----|------------|
| 1 | Housing | 17 | Spacer | 47 | Body assy |
| 3 | Spool assy | 18 | O-ring | 56 | Flange |
| 4 | Spool assy | 19 | Back up ring | 61 | Plug assy |
| 5 | Spool assy | 28 | Poppet | 63 | Bolt |
| 6 | Spool assy | 29 | Spring | 64 | Bolt |
| 7 | Spool assy | 31 | Poppet | 77 | O-ring |
| 12 | Cap | 33 | Spring | 80 | Cap |
| 13 | Cap | 34 | Flange | 81 | Cap |
| 14 | O-ring | 35 | O-ring | 82 | Steel ball |
| 15 | Poppet | 46 | Poppet | 84 | Bolt |
| 16 | Spring | | | | |

3. TIGHTENING TORQUE(1/2)

※ Unit : kgf · m (lbf · ft)

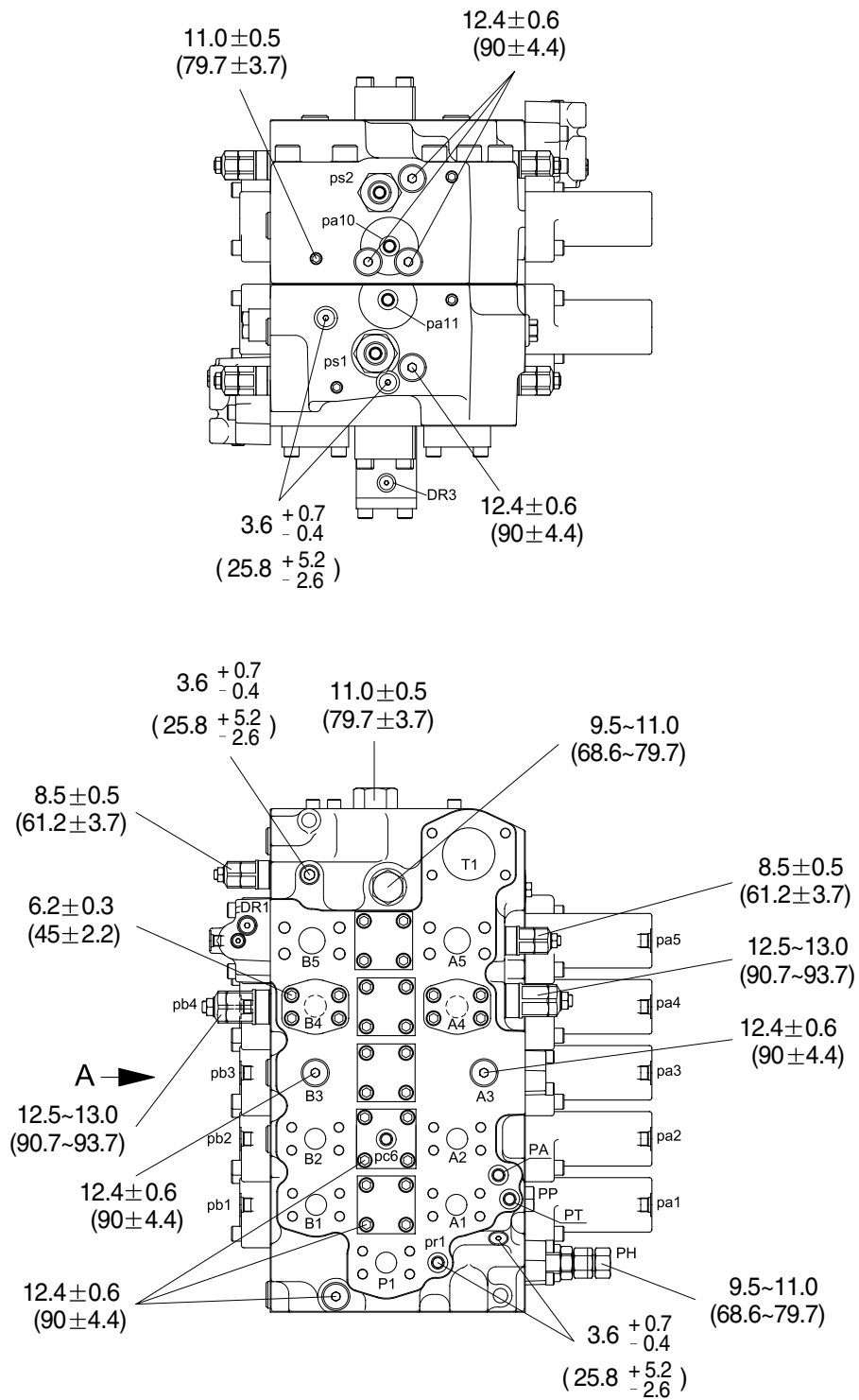

45078MC00

TIGHTENING TORQUE(2/2)

※ Unit : kgf · m (lbf · ft)

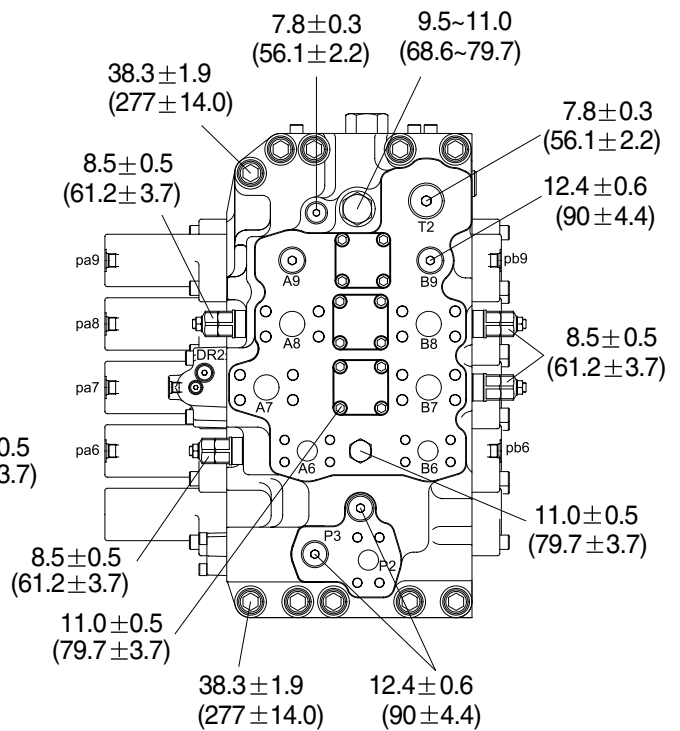
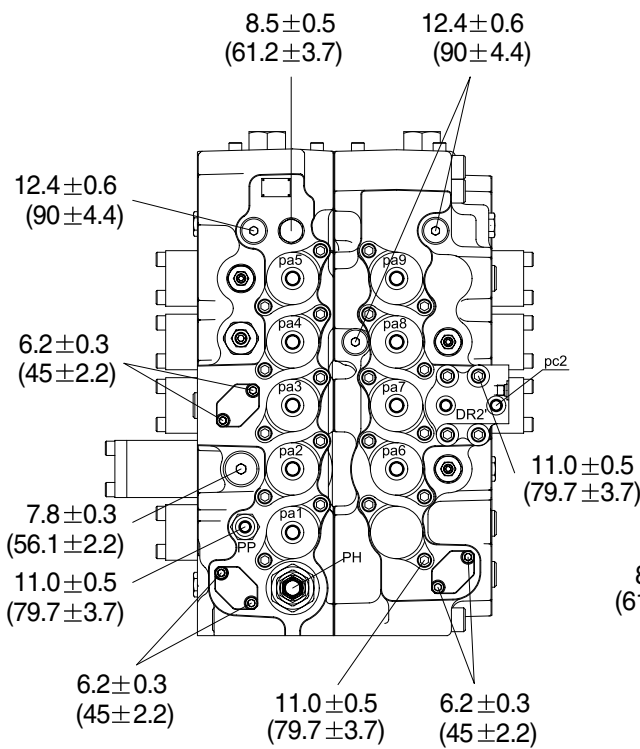
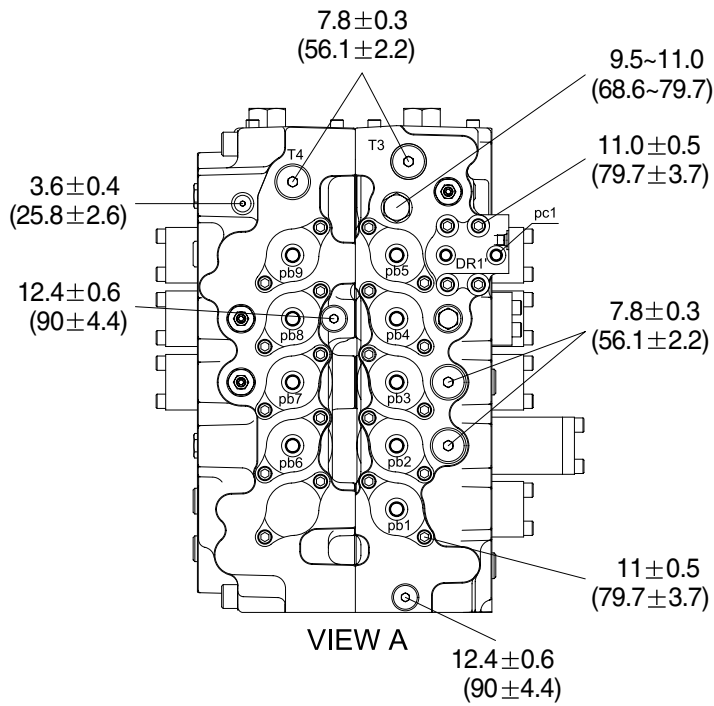

45078MC30

4. DISASSEMBLY AND ASSEMBLY

1) GENERAL PRECAUTIONS

- (1) All hydraulic components are manufactured to a high precision. Consequently, before disassembling and assembling them, it is essential to select an especially clean place.
- (2) In handling a control valve, pay full attention to prevent dust, sand, etc. from entering into it.
- (3) When a control valve is to be removed from the machine, apply caps and masking seals to all ports. Before disassembling the valve, recheck that these caps and masking seals are fitted completely, and then clean the outside of the assembly. Use a proper bench for working. Spread paper or a rubber mat on the bench, and disassemble the valve on it.
- (4) Support the body section carefully when carrying or transferring the control valve. Do not lift by the exposed spool, end cover section etc.
- (5) After disassembling and assembling of the component it is desired to carry out various tests (For the relief characteristics, leakage, flow resistance, etc.), but hydraulic test equipment is necessary for these tests. Therefore, even when its disassembling can be carried out technically, do not disassemble such components that cannot be tested, adjusted, and so on. Additionally one should always prepare clean cleaning oil, hydraulic oil, grease, etc. beforehand.

2) DISASSEMBLY

The figure in () shown after the part name in explanation sentence shows its number in the construction figures.

- (1) Place control valve on working bench.
 - ※ Disassemble the valve in a clean and dry environment and pay careful attention not to damage the sealing flange faces.

(2) Main spool

- ① Loosen socket head bolts(63) and remove the lock cap(12, 80).
Pull out O-ring(14) from valve housing.

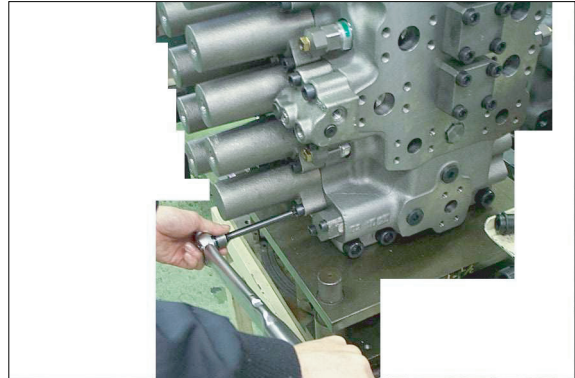

45078MC07

- ② Remove all spool(3~11) of subassembly itself from valve housing.
 - ※ Be careful not to be damaged while pulling out spools. Identify them with a tag to prevent from being mistaken at disassembly.



45078MC08

- ③ Spools sub assy(3, 4, 6, 7, 9, 10, 11).



45078MC10

④ Spool sub assy(5).



45078MC11

⑤ Spool sub assy(8).

- ※ When disassemble the spool assembly, fix the spool with vise. On this occasion attach wood between vise blades to prevent the spool from damaging.
- ※ Heat the outer race of spool with industrial drier and then loosen easily . (Temperature : 200~250°C)



45078MC12

- ⑥ Loosen the socket head bolt(63) and remove the short cap(13, 81).
Pull out O-ring(14) from valve housing.



45078MC09

(3) Center bypass cut spool assy(24)

- ① Loosen the plug(27) and remove spring(25), spring seat(21) and the spool(24).

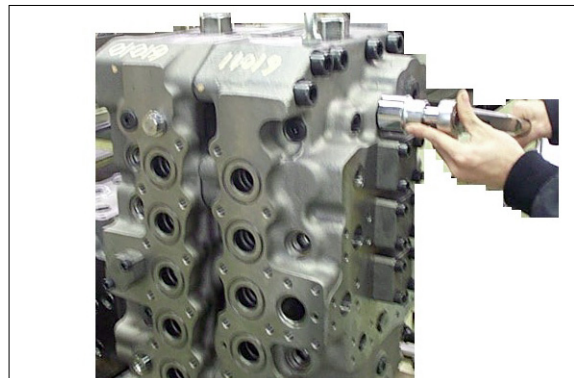

45078MC13

② Pull out O-ring(20).

- ※ When disassemble the spool assembly, fix the spool with vise. On this occasion attach wood between vise blades to prevent the spool from damaging.
- ※ Heat the outer race of spool with industrial drier and then loosen easily .
(Temperature : 200~250°C)

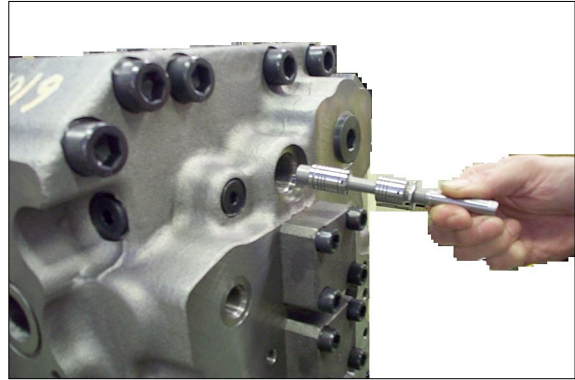

45078MC14

(4) Arm1 regeneration spool assy(20)

① Loosen the plug(23) and pull out O-ring(79).

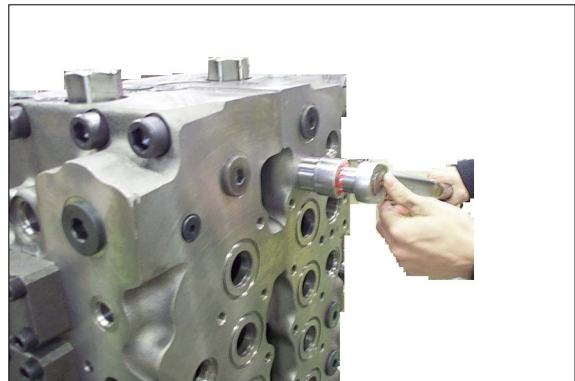

45078MC15

② Disassemble spring(22), spring seat(21) and spool(20).

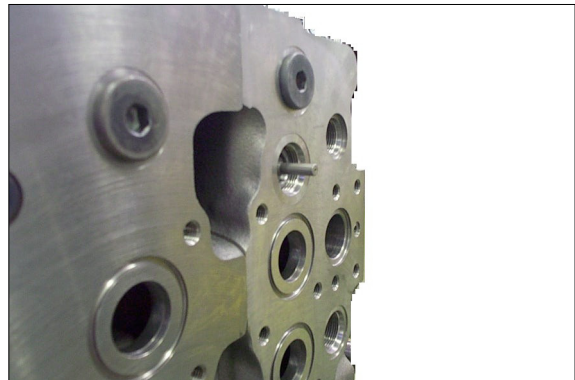

45078MC16

③ Pull out sleeve of hole inside at same time, disassemble sleeve and piston.

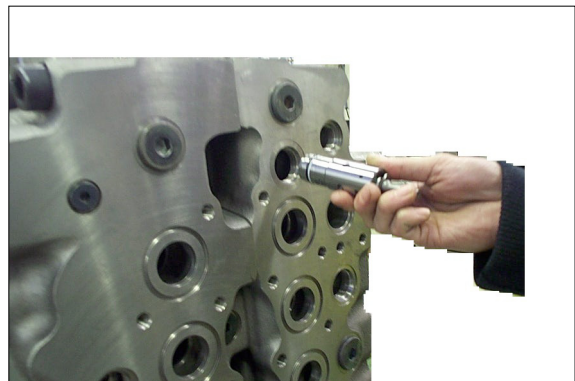

45078MC18

(5) Inspection after disassembly

Clean all disassembled parts with clean mineral oil fully, and dry them with compressed air. Then, place them on clean papers or cloths for inspection.

① Control valve

- a. Check whole surfaces of all parts for burrs, scratches, notches and other defects.
- b. Confirm that seal groove faces of casing and block are smooth and free of dust, dent, rust etc.
- c. Correct dents and damages and check seat faces within the casing, if any, by lapping.
※ Pay careful attention not to leave any lapping agent within the casing.
- d. Confirm that all sliding and fitting parts can be moved manually and that all grooves and paths are free from foreign matter.
- e. If any spring is broken or deformed, replace it with new one.
- f. When a relief valve does not function properly, repair it, following the prescribed disassembly and assembly procedures.
- g. Replace all seals and O-rings with new ones.

② Relief valve

- a. Confirm that all seat faces at ends of all poppets and seats are free of defects and show uniform and consistent contact faces.
- b. Confirm manually that main poppet and seat can slide lightly and smoothly.
- c. Confirm that outside face of main poppet and inside face of seat are free from scratches and so on.
- d. Confirm that springs are free from breakage, deformation, and wear.
- e. Confirm that orifices of main poppet and seat section are not clogged with foreign matter.
- f. Replace all O-rings with new ones.
- g. When any light damage is found in above inspections, correct it by lapping.
- h. When any abnormal part is found, replace it with a completely new relief valve assembly.

3) ASSEMBLY

(1) General comments

- ① In this assembly section, explanation only is shown.
For further understanding, please refer to the figures and photographs shown in the previous disassembly section.
- ② Figure in () shown after the part name in the explanation refers to the reference identity number shown on the construction figure shown in the spares section.
- ③ **Cautions in assembling seal**
 - a. Pay close attention to keeping all seals free from handling damage and inspect carefully for damage before using them.
 - b. Apply clean grease or hydraulic oil to the seal so as to ensure it is fully lubricated before assembly.
 - c. Do not stretch seals so much as to deform them permanently.
 - d. In fitting O-rings, pay close attention not to roll them into their final position in addition, a twisted O-ring cannot easily untwist itself naturally and could thereby cause inadequate sealing and thereby both internal and external oil leakage.
 - e. Tighten fitting bolts for all sections with a torque wrench adjusted to the respective tightening torque as shown on the cross section drawings of the spares section.

(2) Main spool

- ① Apply loctite to thread of spools(3, 4, 6, 7, 9, 10, 11) and assemble spring seat, spring and spool end. Assemble spool end to spool after fixing spool with a vise attached wood.
※ Be careful not to applying loctite too much.
· Tightening torque : 2.4 ~ 2.6 kgf · m(17.4 ~ 18.8lbf · ft)
Fit O-ring into housing and assemble spools(3, 4, 6, 7, 9, 10, 11) into housing.
Assemble lock cap on housing and tighten hex socket bolt.
· Tightening torque : 11 ± 0.5 kgf · m(79.7 ± 3.7 lbf · ft)
- ② Insert poppet, spring into spool(5) and then apply loctite to thread of spool.
Fit O-ring and backup ring on the plug and then tighten plug.
Assemble spring seat, spring, and spool end and then assemble spool end sub assy to spool after fixing spool with a vise attached wood.
· Tightening torque : 2.4 ~ 2.6 kgf · m(17.4 ~ 18.8lbf · ft)
Fit O-ring into housing and assemble spool(5) into housing.
Assemble lock cap on housing and tighten hex socket bolt.
· Tightening torque : 11 ± 0.5 kgf · m(79.7 ± 3.7 lbf · ft)
- ③ Insert poppet, spring into spool(8) and then apply loctite to thread for spool.
Fit O-ring and backup ring on the plug and then tighten plug.
Assemble spring seat, spring, and spool end and then assemble spool end sub assy to spool after fixing spool with a vise attached wood.
· Tightening torque : 2.4 ~ 2.6 kgf · m(17.4 ~ 18.8lbf · ft)
Fit O-ring into housing and assemble spool(8) into housing.
Assemble lock cap on housing and tighten hex socket bolt.
· Tightening torque : 11 ± 0.5 kgf · m(79.7 ± 3.7 lbf · ft)
- ④ Assemble short cap on housing and tighten hex socket bolt.
· Tightening torque : 11 ± 0.5 kgf · m(79.7 ± 3.7 lbf · ft)

(3) Center bypass cut spool assy(24)

- ① Apply loctite to thread of spool, assemble spool end to spool.
 - ※ Be careful not to applying loctite too much.
- ② Assemble spool assy, spring seat, spring and tighten plug with O-ring.
 - Tightening torque : 9.5 ~ 11.0 kgf · m(68.6 ~ 79.7lbf · ft)

(4) Arm1 regeneration spool assy(20)

- ① Assemble backup rings and O-rings to sleeve respectively.
- ② Assemble piston to sleeve which seal is assemble, and insert spool into sleeve.
- ③ Assemble spool assy, spring seat, spring and tighten plug with O-ring.
 - Tightening torque : 9.5 ~ 11.0 kgf · m(68.6 ~ 79.7lbf · ft)