

GROUP 4 HYDRAULIC SYSTEM

HYDRAULIC COMPONENTS MOUNTING 1

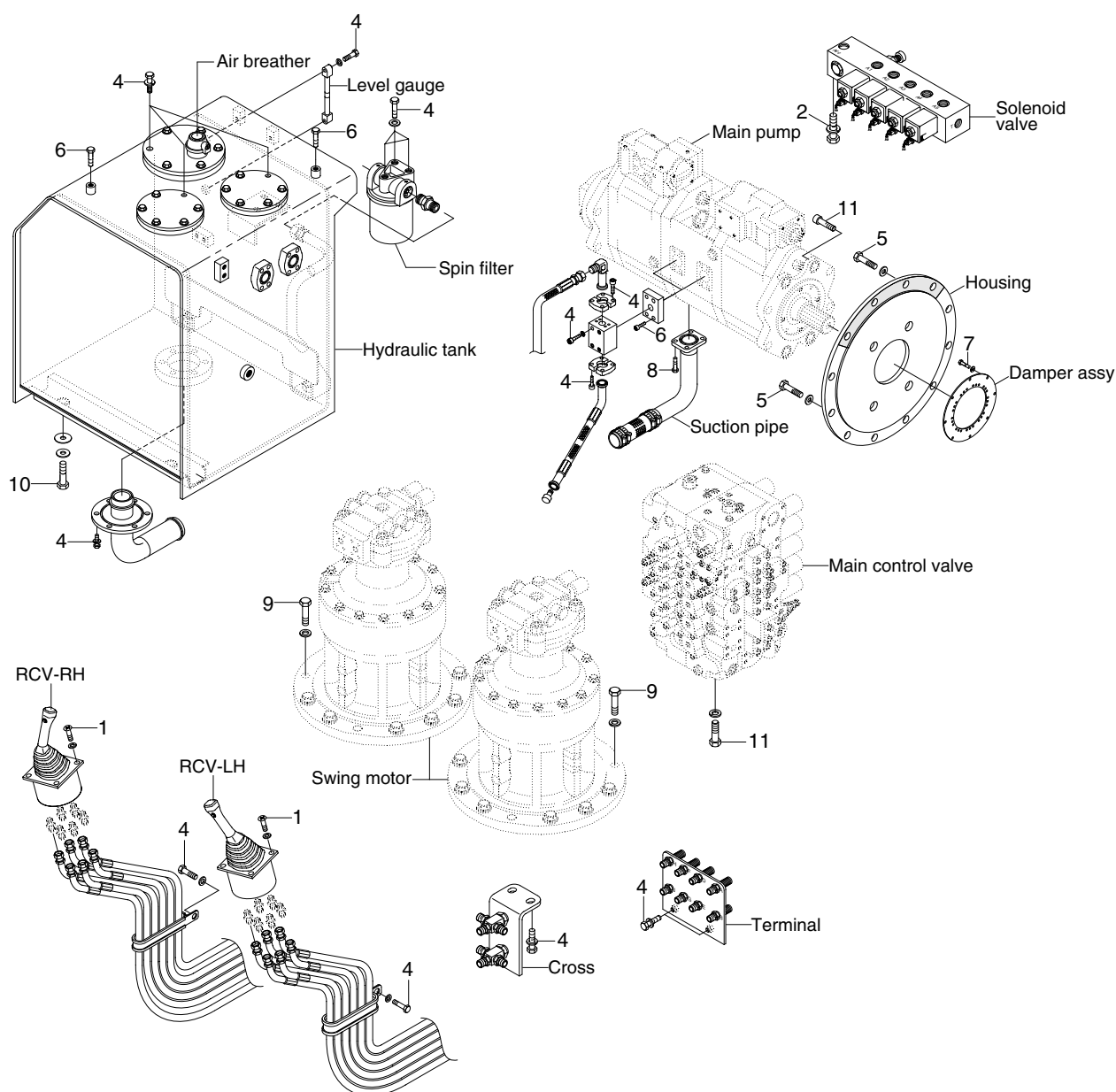

50079CM05

· Tightening torque

Item	Size	kgf · m	lbf · ft
1	M 6×1.0	1.05±0.2	7.6±1.45
2	M 8×1.25	2.5±0.5	18.1±3.6
3	M10×1.5	4.8±0.3	34.7±2.2
4	M10×1.5	6.9±1.4	49.9±10.1
5	M10×1.5	4.6±1.0	33.3±7.2
6	M12×1.75	12.2±1.3	88.2±9.4

Item	Size	kgf · m	lbf · ft
7	3/8-16UNC	4.6±1.0	33.3±7.2
8	M16×2.0	29.7±4.4	215±31.8
9	M20×2.5	58.4±6.4	422±46.3
10	M20×2.5	46±5.1	333±36.9
11	M20×2.5	44±6.6	318±47.7
-	-	-	-

HYDRAULIC COMPONENTS MOUNTING 2

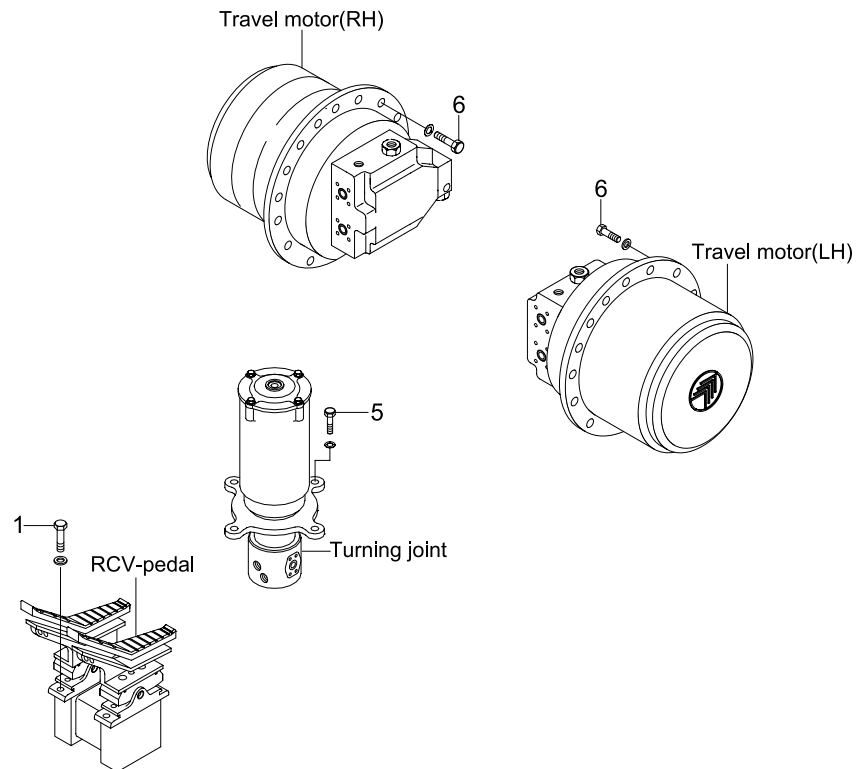

Boom safety lock system

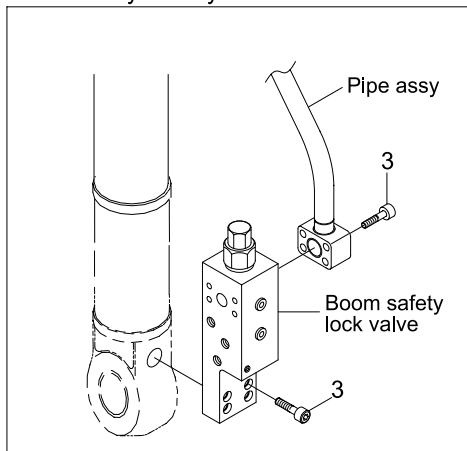

Arm safety lock system

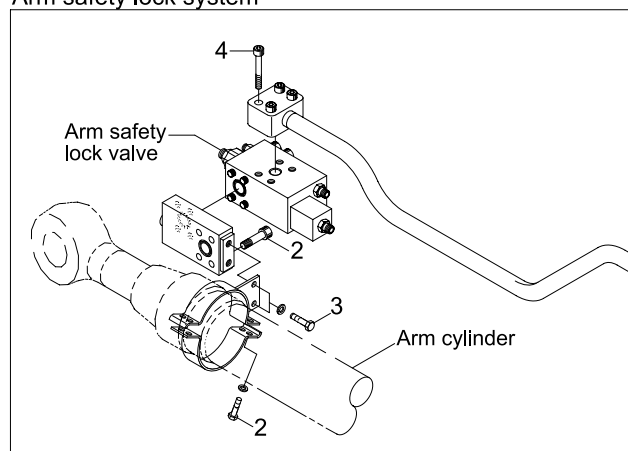

50079CM06

· Tightening torque

Item	Size	kgf · m	lbf · ft
1	M10×1.5	6.9±1.4	49.9±10.1
2	M10×1.5	5.4±0.5	39.1±3.6
3	M12×1.75	12.8±3.0	92.6±21.7

Item	Size	kgf · m	lbf · ft
4	M14×2.0	19.6±2.9	142±21
5	M16×2.0	29.7±4.5	215±32.5
6	M20×2.5	57.9±8.7	419±62.9

HYDRAULIC COMPONENTS MOUNTING 3

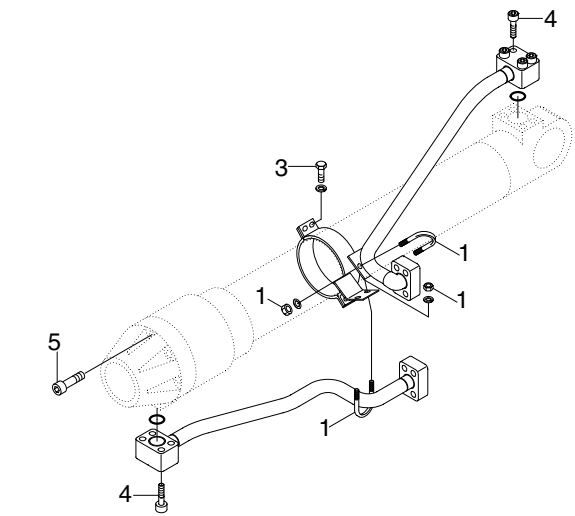

BOOM CYLINDER

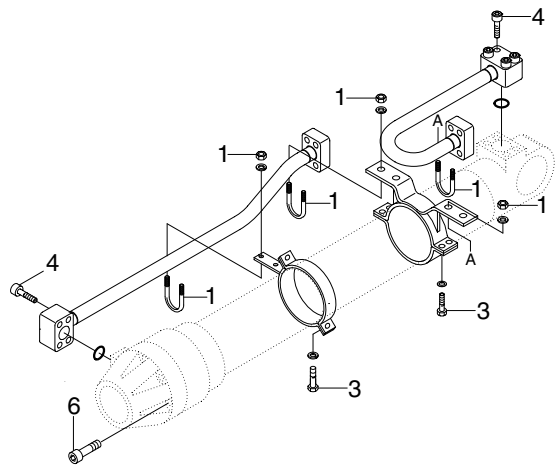
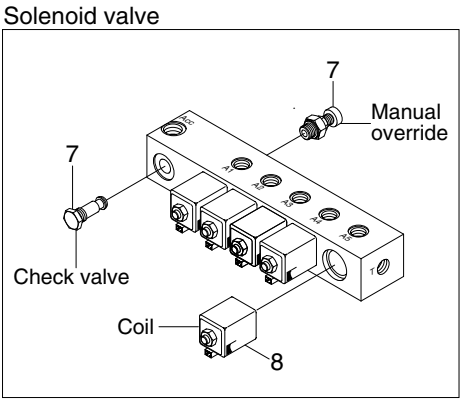

ARM CYLINDER

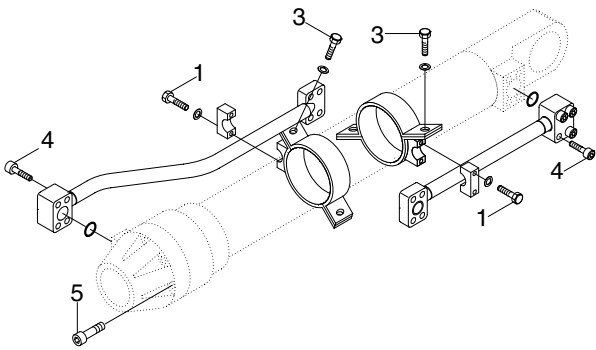

BUCKET CYLINDER

50079CM07

· Tightening torque

Item	Size	kgf · m	lbf · ft
1	M10×1.5	3.2±0.3	23.1±2.2
2	M10×1.5	5.4±0.5	39.1±3.6
3	M12×1.75	5.5±0.6	39.8±4.3
4	M12×1.75	9.4±1.0	68.0±7.2

Item	Size	kgf · m	lbf · ft
5	M22×2.5	63±6.0	456±43.3
6	M24×3.0	79±8.0	571±57.9
7	M22×2.5	4.1	29.7
8	M27×3.0	5.1	36.9