

# GROUP 2 ENGINE SYSTEM

## ENGINE AND ACCESSORIES MOUNTING

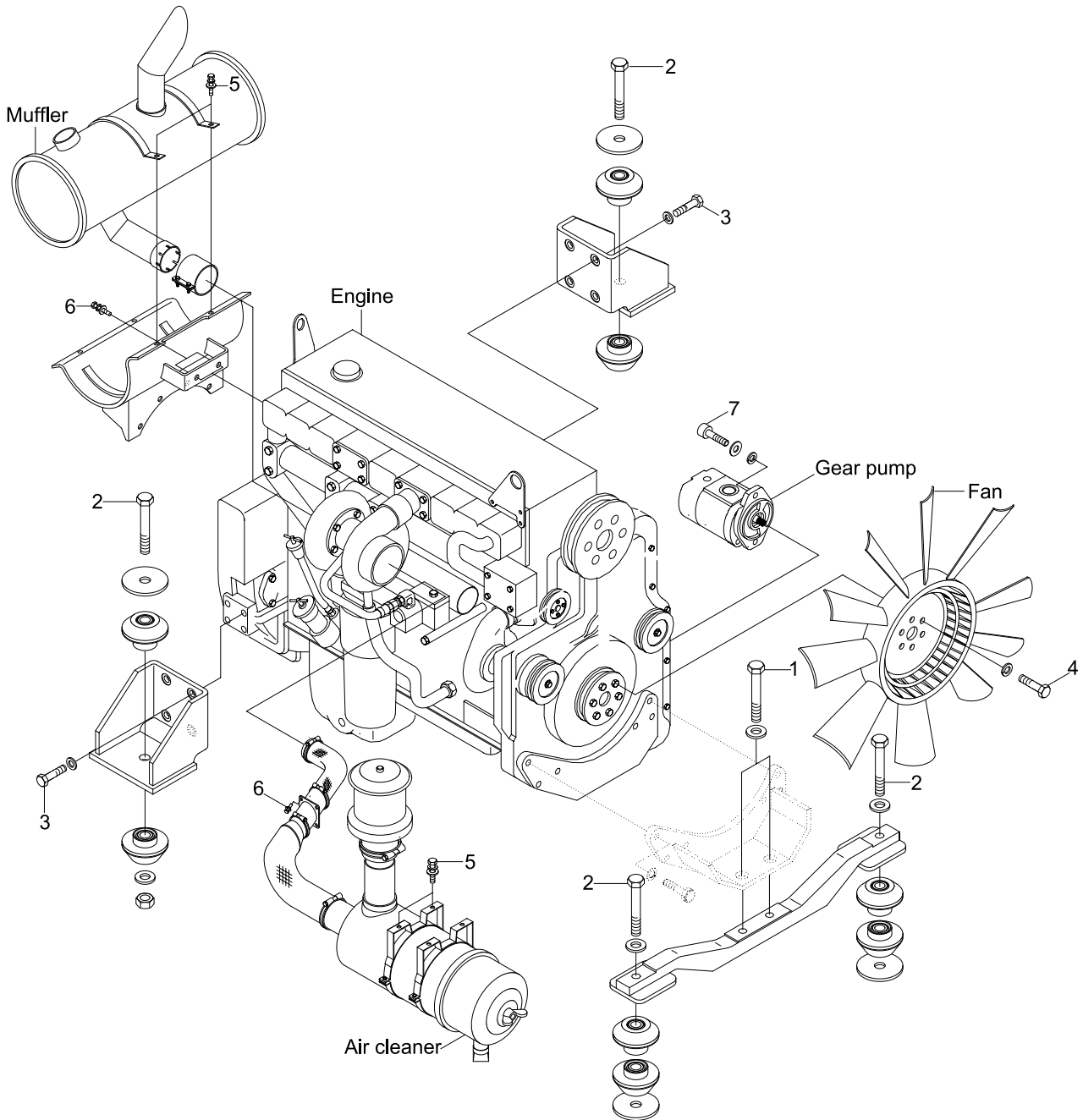

50079CM01

· Tightening torque

Item	Size	kgf · m	lbf · ft
1	M20×2.5	57.9±8.7	419±62.9
2	M20×2.5	46.4±4.6	336±33.0
3	M16×2.0	19.0±3.0	137±21.7
4	3/8-16UNC	6.1±1.0	44.1±7.2

Item	Size	kgf · m	lbf · ft
5	M10×1.5	6.9±1.4	49.9±10.1
6	M12×1.75	12.2±1.3	88.2±9.4
7	M 8×1.25	3.4±0.7	24.6±5.1
-	-	-	-

# COOLING SYSTEM AND FUEL TANK MOUNTING

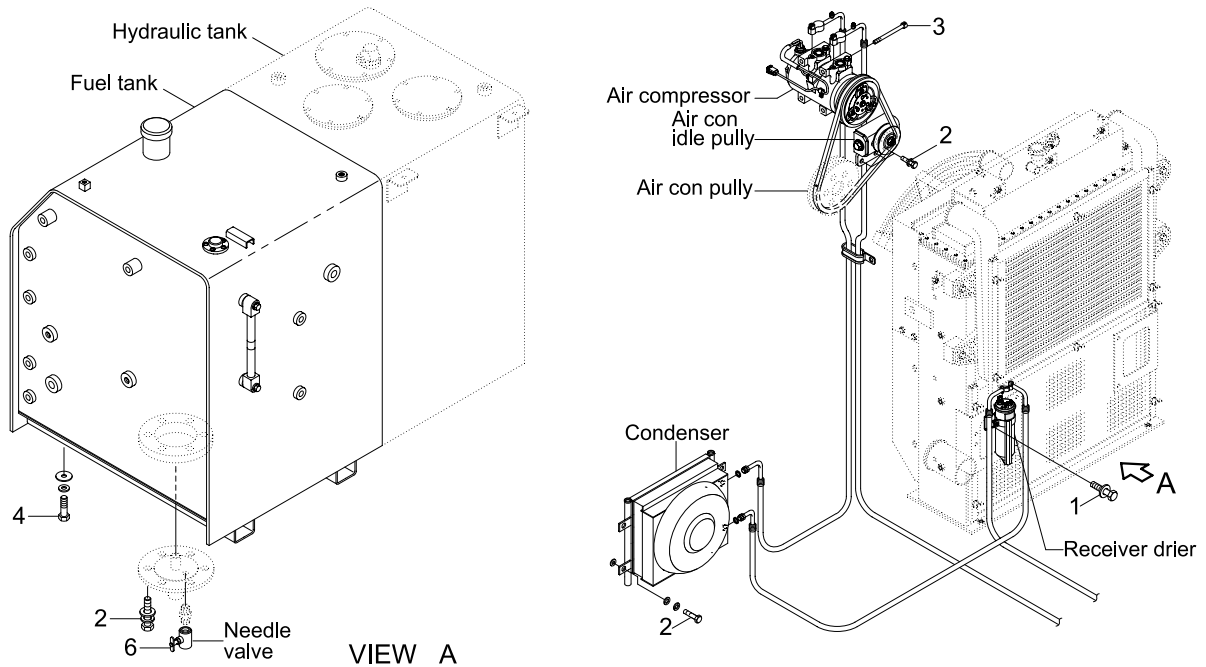

VIEW A

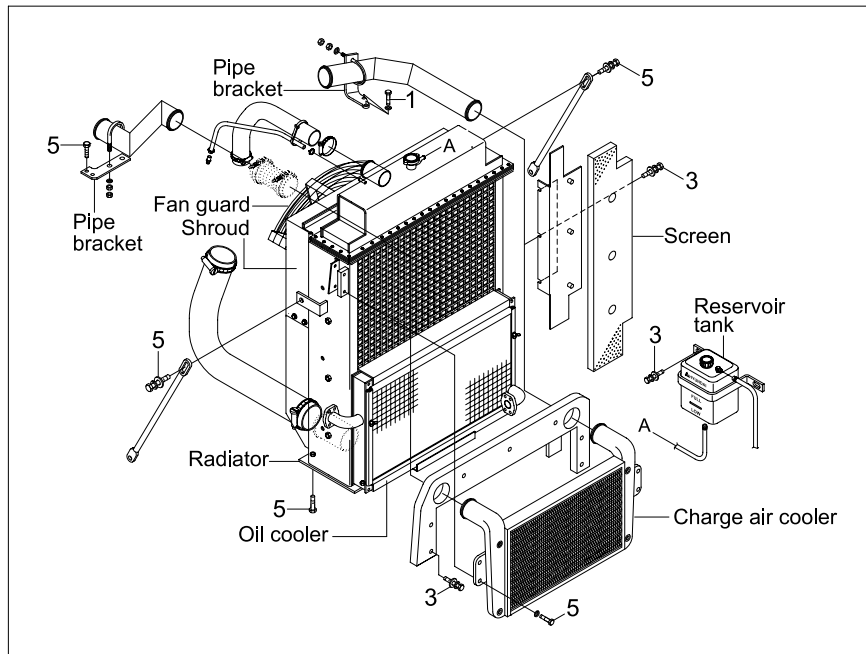

45079CM02

## · Tightening torque

Item	Size	kgf · m	lbf · ft
1	M 6×1.0	1.05±0.2	7.6±1.45
2	M10×1.5	6.9±1.4	49.9±10.1
3	M 8×1.25	2.5±0.5	18.1±3.6

Item	Size	kgf · m	lbf · ft
4	M20×2.5	45±5.1	325±36.9
5	M12×1.75	12.8±3.0	92.6±21.7
6	-	2.3±0.6	16.6±4.3