

GROUP 6 TRAVEL DEVICE (TYPE 1)

1. REMOVAL AND INSTALL

1) REMOVAL

- (1) Swing the work equipment 90° and lower it completely to the ground.
- (2) Operate the control levers and pedals several times to release the remaining pressure in the hydraulic piping.
- (3) Loosen the breather slowly to release the pressure inside the hydraulic tank.

▲ Escaping fluid under pressure can penetrate the skin causing serious injury.

- ※ When pipes and hoses are disconnected, the oil inside the piping will flow out, so catch it in oil pan.
- (4) Remove the track shoe assembly.
For details, see removal of track shoe assembly.
 - (5) Remove the cover.
 - (6) Remove the hose.
 - ※ Fit blind plugs to the disconnected hoses.
 - (7) Remove the bolts and the sprocket.
 - (8) Sling travel device assembly (1).
 - (9) Remove the mounting bolts (2), then remove the travel device assembly.
 - Weight : 360 kg (790 lb)

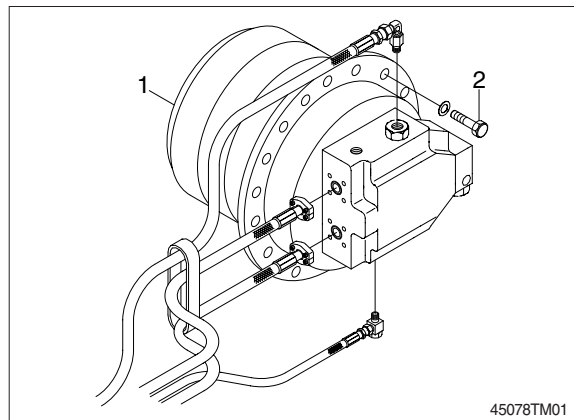

2) INSTALL

- (1) Carry out installation in the reverse order to removal.
- (2) Bleed the air from the travel motor.
 - ① Remove the air vent plug.
 - ② Pour in hydraulic oil until it overflows from the port.
 - ③ Tighten plug lightly.
 - ④ Start the engine, run at low idling, and check oil come out from plug.
 - ⑤ Tighten plug fully.
- (3) Confirm the hydraulic oil level and check the hydraulic oil leak or not.

2. TRAVEL MOTOR (1/2)

1) STRUCTURE

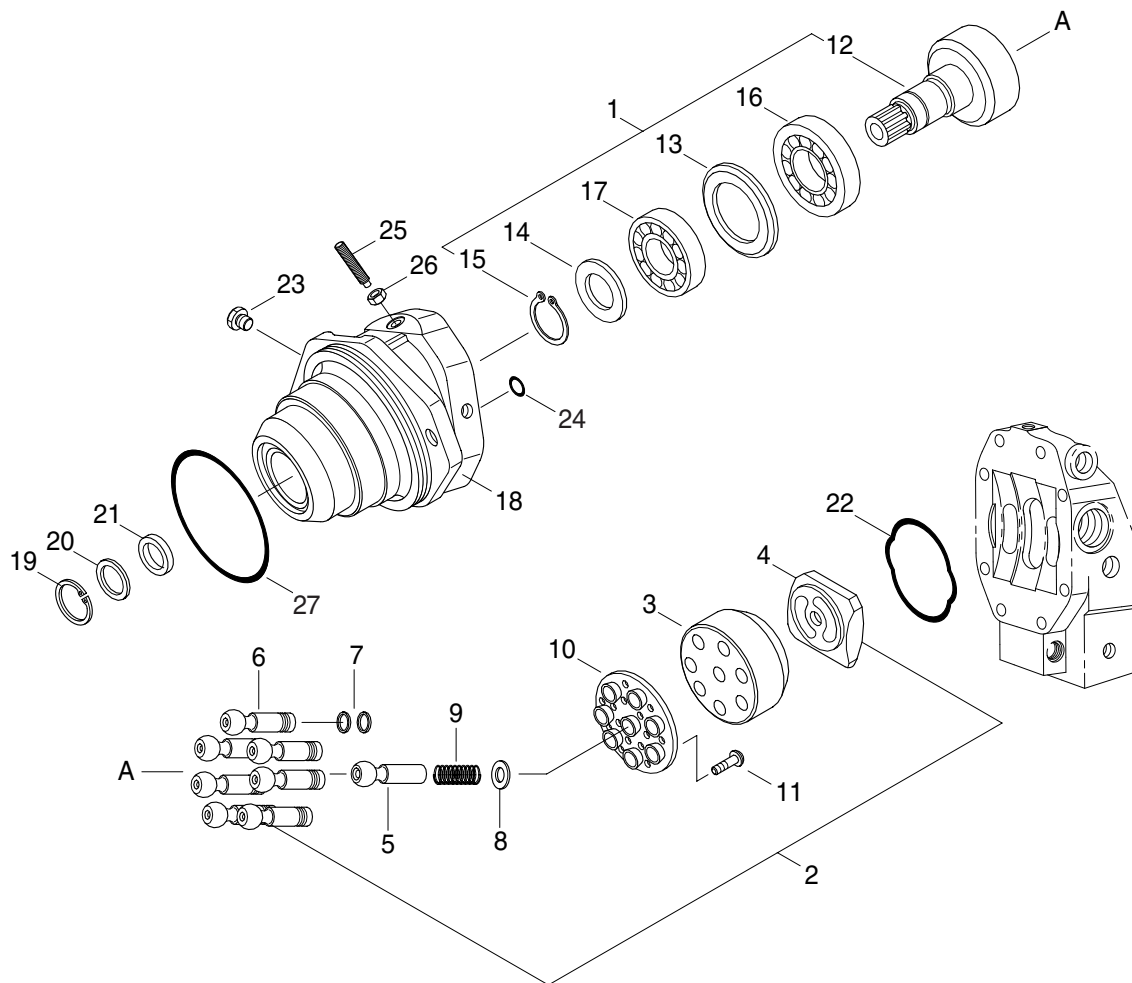

450A8TO02

1	Rotary group	10	Retainer plate	19	Retainer ring
2	Hyd section rotary	11	Screw	20	Shaft seal ring
3	Cylinder	12	Drive shaft	21	Back up plate
4	Control lens	13	Shim	22	O-ring
5	Center pin	14	Back up plate	23	Locking screw
6	Piston	15	Retainer ring	24	O-ring
7	Steel ring	16	Roller bearing	25	Threaded pin
8	Adjustment shim	17	Roller bearing	26	Seal lock nut
9	Pressure spring	18	Housing	27	O-ring

TRAVEL MOTOR (2/2)

· Control part

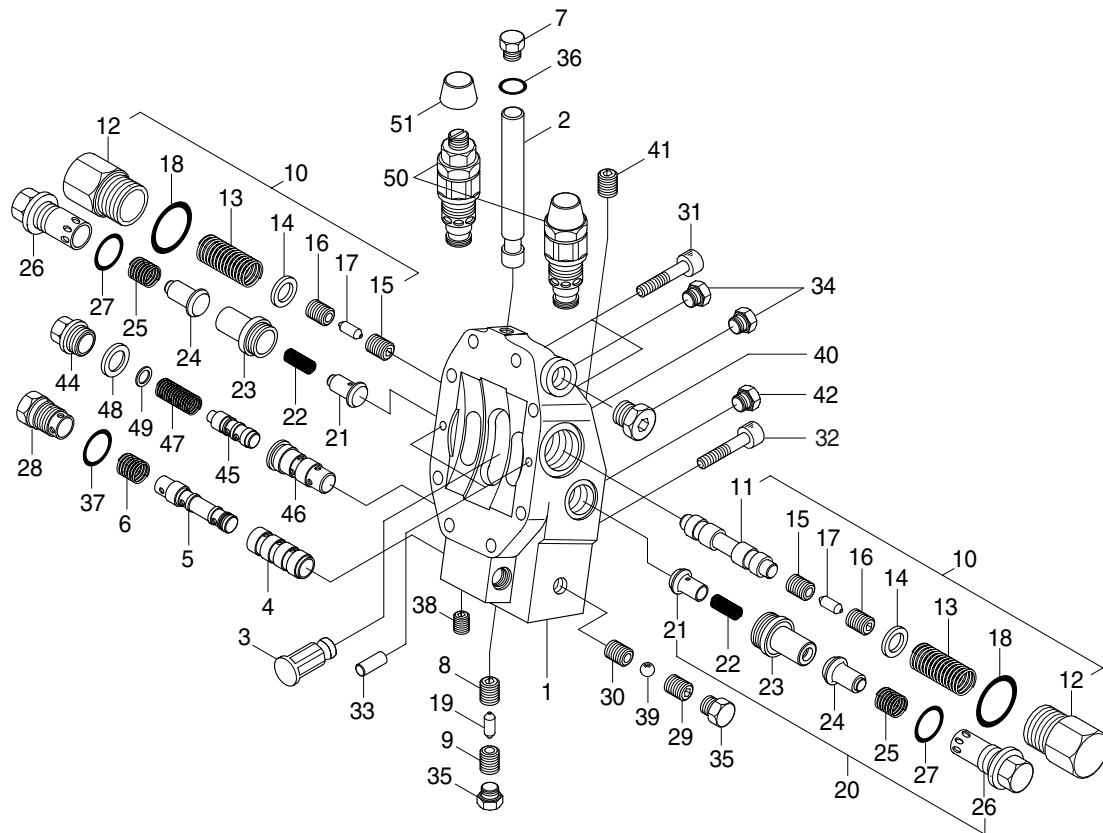

450A8TO03

1	Port plate	18	O-ring	35	Locking screw
2	Position piston	19	Throttle pin	36	O-ring
3	Position turnnion	20	Valve	37	O-ring
4	Control bushing	21	Poppet valve	38	Brake off pin
5	Control piston	22	Pressure spring	39	Ball
6	Pressure spring	23	Seat poppet	40	Locking screw
7	Locking screw	24	Poppet valve	41	Brake off pin
8	Throttle screw	25	Pressure spring	42	Locking screw
9	Throttle screw	26	Locking screw	43	Pressure control valve
10	Brake valve	27	O-ring	44	Locking screw
11	Brake piston	28	Locking screw	45	Control piston
12	Locking screw	29	Valve screw	46	Control bushing
13	Pressure spring	30	Bushing	47	Pressure spring
14	Washer	31	Socket screw	48	O-ring
15	Throttle screw	32	Socket screw	49	Shim
16	Throttle screw	33	Cylinder pin	50	Relief pressure valve
17	Throttle pin	34	Locking screw	51	Cap

2) TOOLS AND TIGHTENING TORQUE

(1) Tools

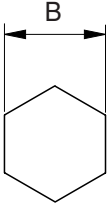
Tool name	Remark	
Allen wrench	2.5	
	4	
	6	
	8	
	10	
	14	
Socket for socket wrench, spanner	19	
Torque wrench	Capable of tightening with the specified torques.	
Pliers	-	
(-) Driver	150 mm	
Plastic and iron hammer	Wooden hammer allowed. Nominal 1 or so	
Steel rod approx	7 × 7 × 200 mm	
Monkey wrench	-	
Oil seal inserting jig	-	
Bearing pliers	-	
Seal tape	-	
Press (0.5 ton)	-	
Oil stone	-	
Bearing assembling jig	-	
Liquid packing	Loctite #577	
Screw lock	Loctite #243	

(2) Tightening torque

Part name	Item	Size	Torque	
			kgf·m	lbf·ft
Locking screw	11	M 6 × 20	1.0	7.4
Locking screw	13	M26 × 1.5	7.0	50.9
Locking nut	18	M12	7.0	50.9
Socket head screw	20, 21	M16 × 90	-	-
Socket head screw	22	M16 × 120	-	-
Locking screw	24	M14 × 1.5	3.0	22
Locking screw	25	M10 × 1	1.0	7
Locking screw	30	M27 × 2.0	9.1	66
Locking screw	32	M16 × 1.5	7.0	50.9

3) DISASSEMBLY

(1) General precautions

- ① Before disassembling the motor, check the items to be inspected and, for remedy against trouble, closely examine the nature of the trouble, so that the motor can be disassembled effectively.
- ② To disassemble the motor, use the disassembling procedures described in section 2) and select a clean place.
- ③ Place a rubber or vinyl sheet or other such protective materials on your working bench to protect the surface of the motor to be serviced.
- ④ During disassembly, give a match mark to the mating surfaces of each part.
- ⑤ Arrange removed parts in order so that they will not become damaged or missing during disassembly.
- ⑥ Once seals have been disassembled, they should be replaced even if damage is not observed. Have replacement seals ready on hand before starting your disassembling job.

(2) Seal kit and component groups

① Attention

Observe the following notices when carrying out repair work at hydraulic aggregates!



② Close all ports of the hydraulic aggregates.

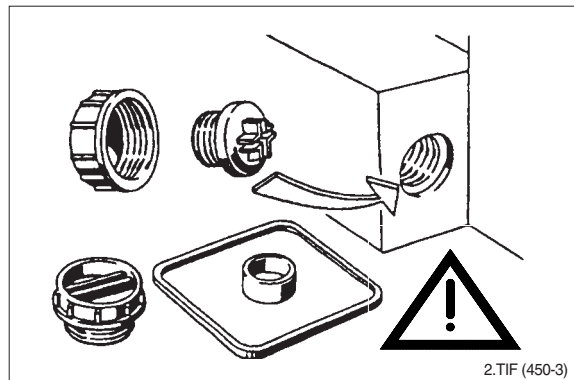

③ Replace all seals.

Use only original spare parts.

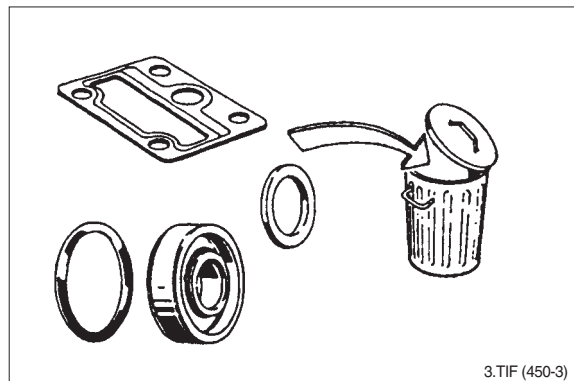

④ Check all seal and sliding surfaces for wear.

Rework of sealing area for example with abrasive paper can damage surface.

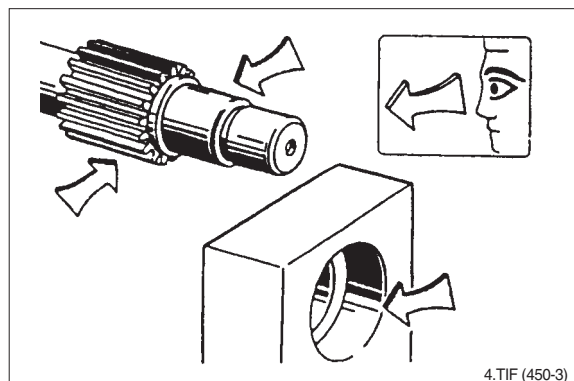

- ⑤ Fill up hydraulic aggregates with hydraulic oil before start-up.

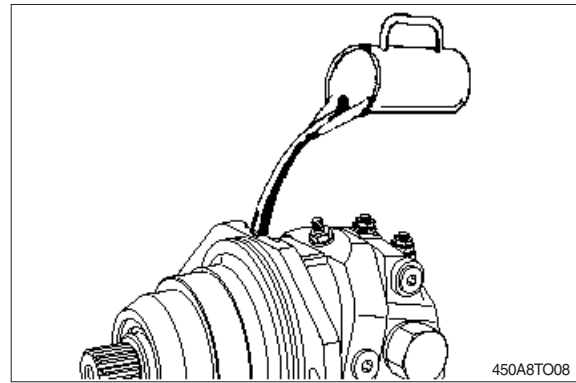

- ⑥ Seal kit for drive shaft.

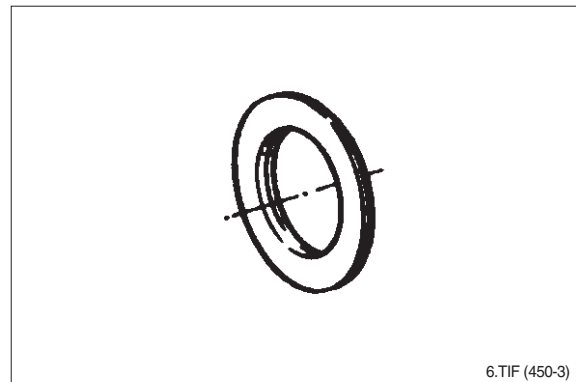

- ⑦ External seal kit.

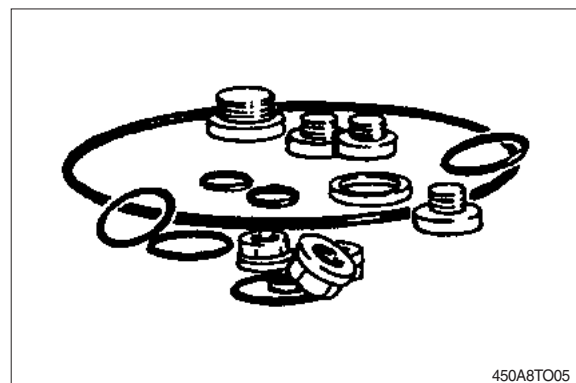

- ⑧ Housing.

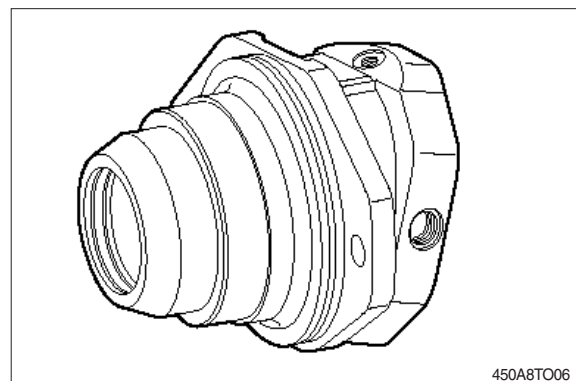

⑨ Complete rotary group.

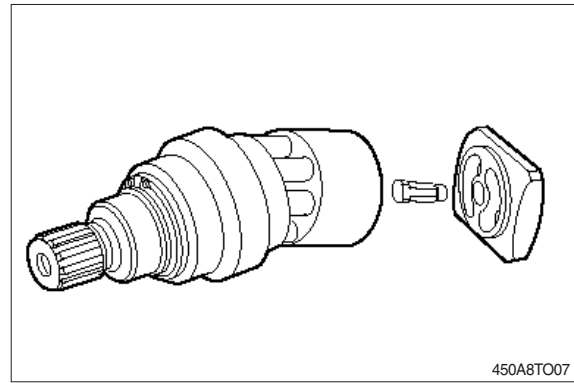

⑩ Port plate with control piston and counter-balance valve.

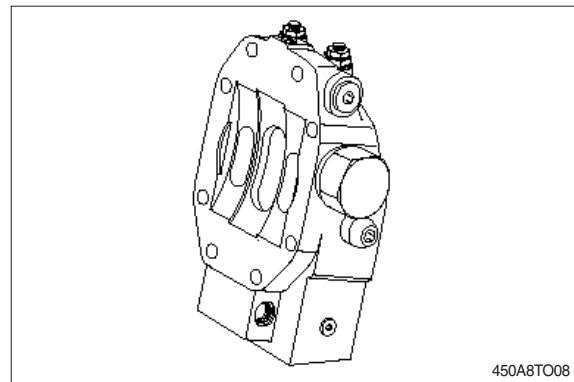

⑪ Relief valve/Make up check valve

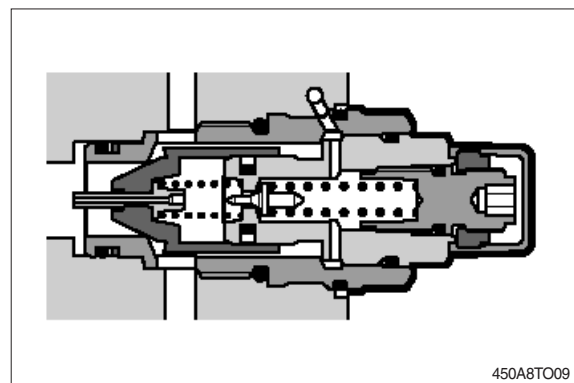

⑫ Replace seal nut.
First measure and record setting height.

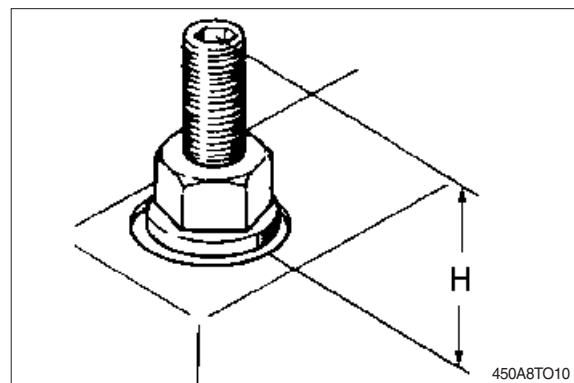

- ⑬ When tightening, counterhold setting screw, then check setting height.

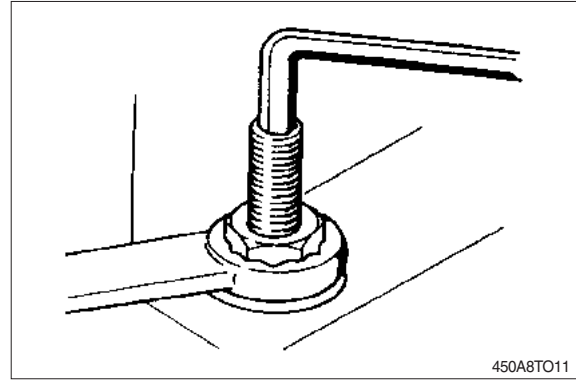

(3) Sealing the drive shaft

- ① Protecting the drive shaft.
Remove retaining ring and shim.

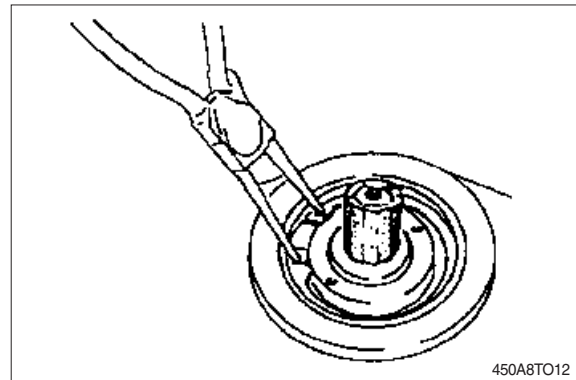

- ② Screw in sheet metal screw into the holes fitted with rubber.
Pull out seal with pliers.

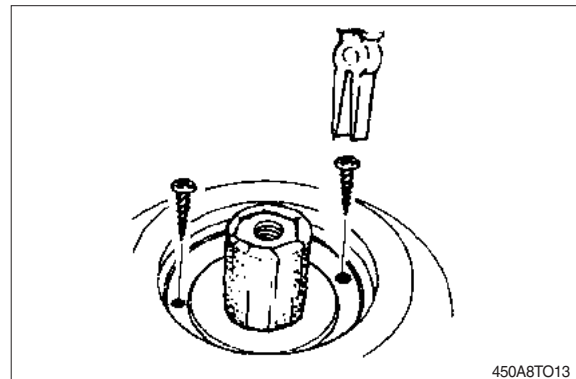

- ③ Press in shaft seal and shim with bush to stop.
※ Pay attention to pressing depth!
★ Mark for pressing depth.
Assemble retaining ring.

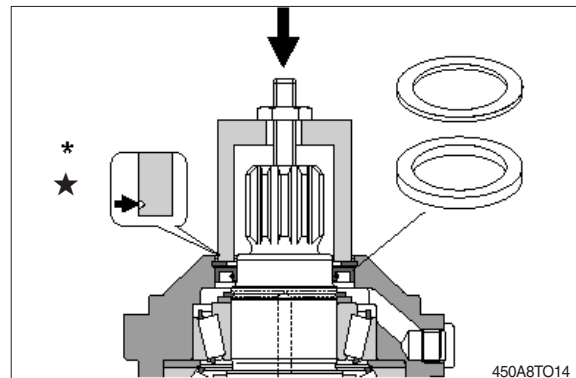

(4) Sealing of the control parts

- ① HZ-Controller
- ※ O-ring, O-ring groove, housing.

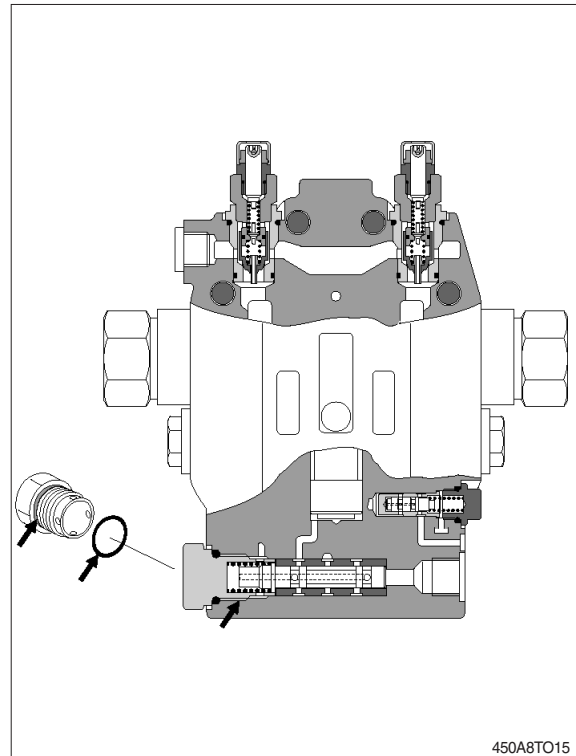

(5) Sealing of the relief valve

- ① Remove relief valve.

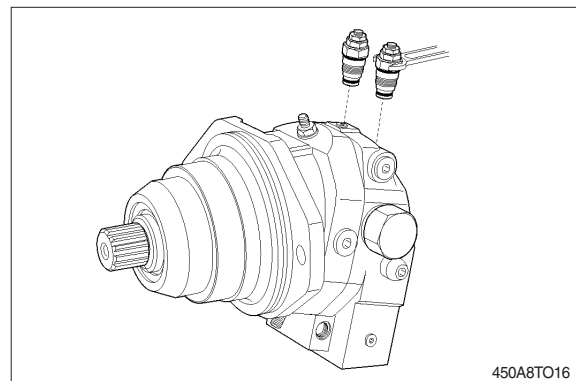

- ② Inspect O-ring.

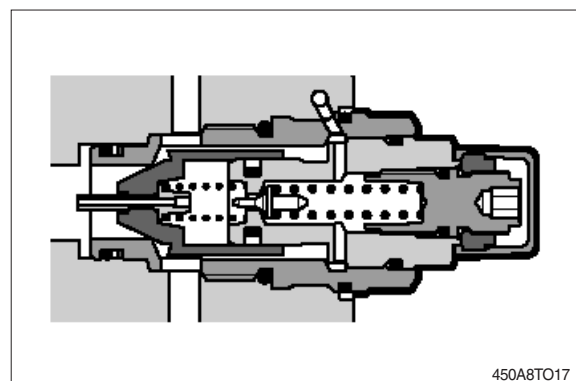

(6) Disassembly of the port plate

- ① Note dimension x .
Remove Q_{\min} -screw.

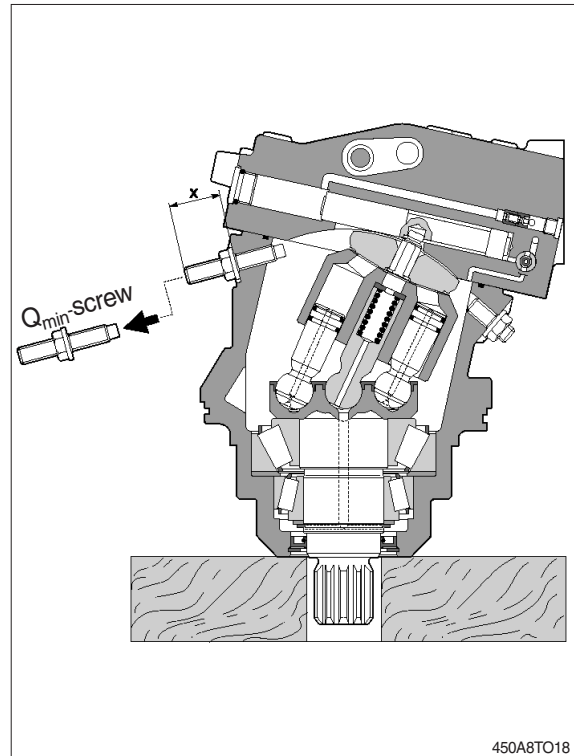

- ② For disassembly of the port plate, swivel always rotary group to zero position. Piston rings to hang out of the cylinder boring. Swivel rotary group to zero position with screw Q_{\max} .

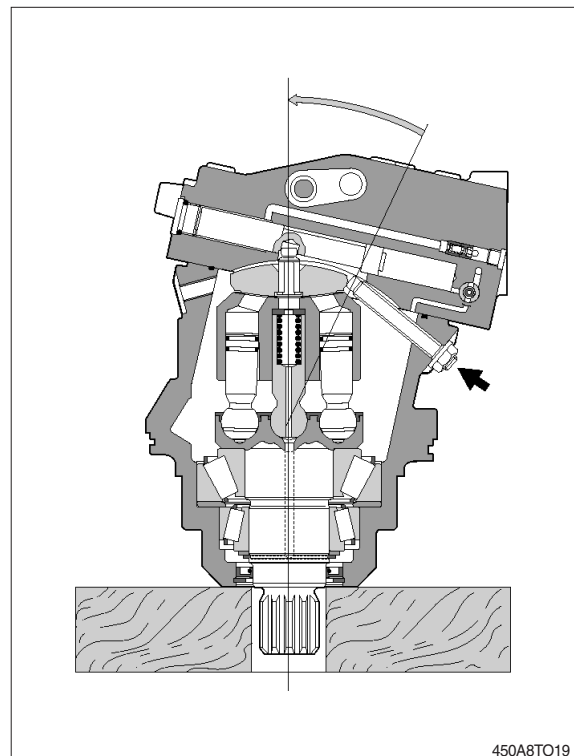

- ③ Port plate
Mark position. Loosen screws.
Removal.

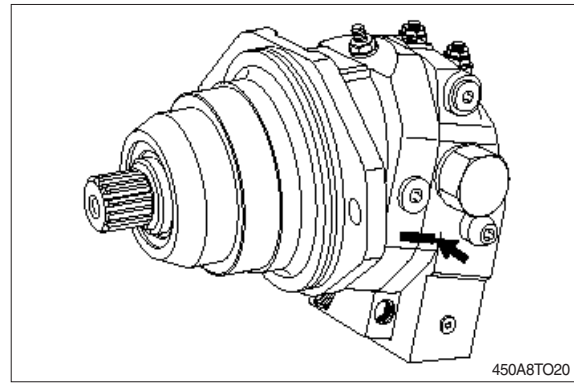

- ④ Check O-ring.
※ Stick new O-ring with some grease. Do not swivel rotary group. Piston rings to hang out from the cylinder boring.

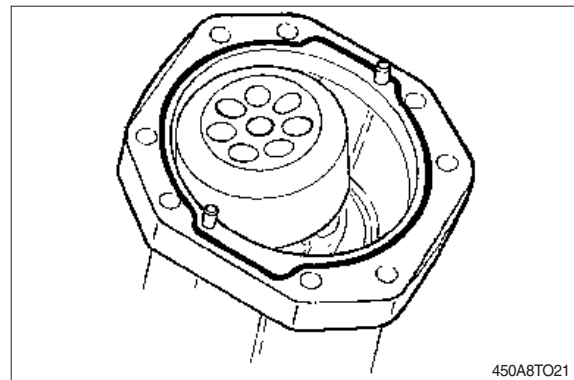

(7) Remove rotary group

- ① Screw in threaded pin into center pin.
Fix the cylinder with disc and lock nut.
Size : M8 × 105 mm

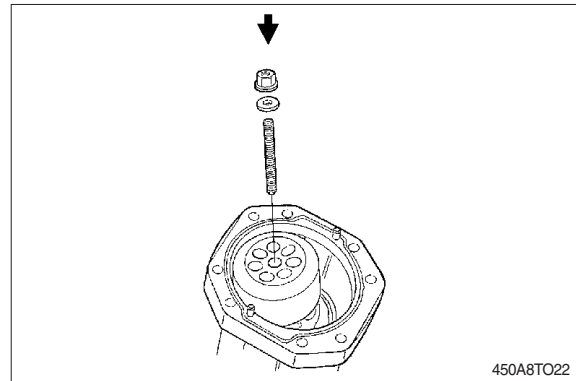

- ② Press out rotary group!
※ If the bearings are used again do not hit on the drive shaft.

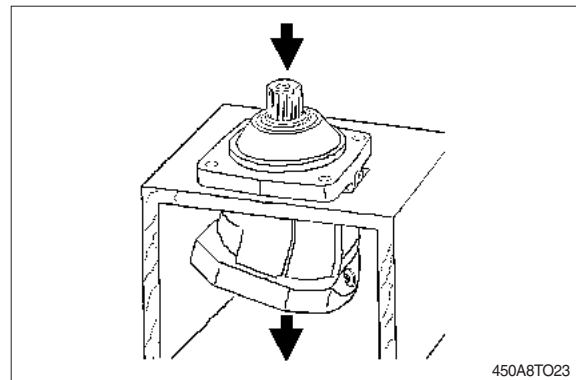

(8) Exchanging of the rotary group

- ① Remove fixing screw (cylinder).
Remove cylinder.

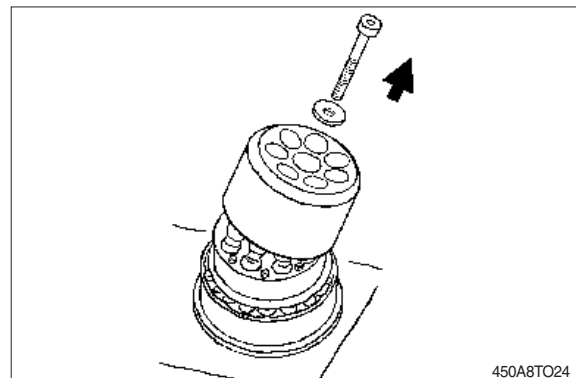

- ② Disassemble retaining plate.
※ Screws are glued. Use Torx-tools.

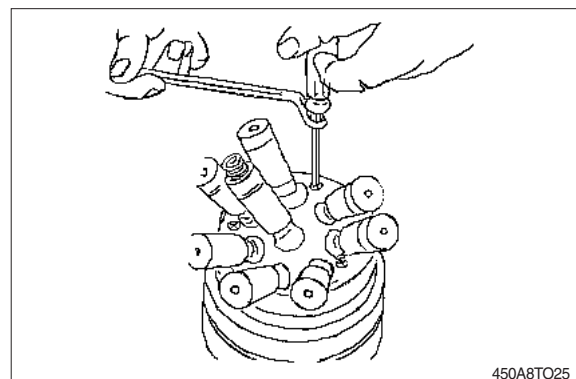

4) ASSEMBLY

(1) General precautions

- ① Reassemble in a work area that is clean and free from dust and grit.
- ② Handle parts with bare hands to keep them free of liny contaminates.
- ③ Repair or replace the damaged parts.
Each parts must be free of burrs its corners.
- ④ Do not reuse O-rings, oil seal and floating seal that were removed in disassembly.
Provide the new parts.
- ⑤ Wash all parts thoroughly in a suitable solvent.
Dry thoroughly with compressed air.
Do not use the cloths.
- ⑥ When reassembling oil motor components of motor, be sure to coat the sliding parts of the motor and valve with fresh hydraulic oil. (NAS class 9 or above)
- ⑦ Use a torque wrench to tighten bolts and plugs, to the torque specified as follows.

(2) Rotary group assembly

- ① Rotary group completely assembled ready for assembly.

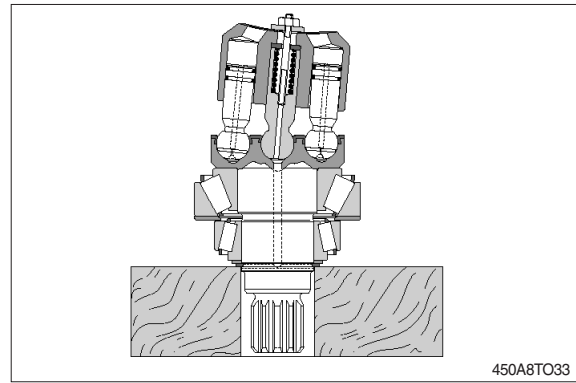

- ② Place assembly sleeve.

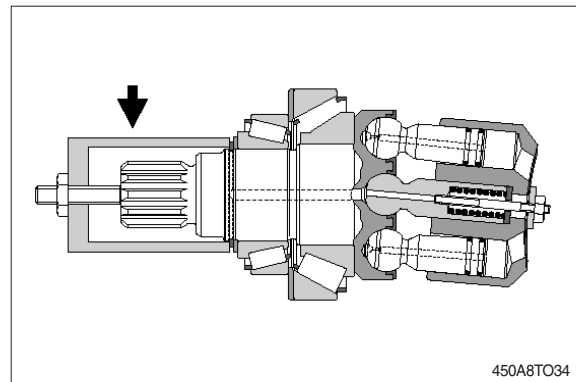

- ③ Warm up housing to 80°C.

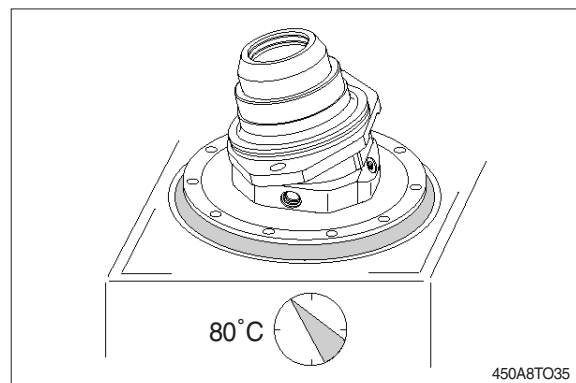

- ④ Insert rotary group into housing to seat position.

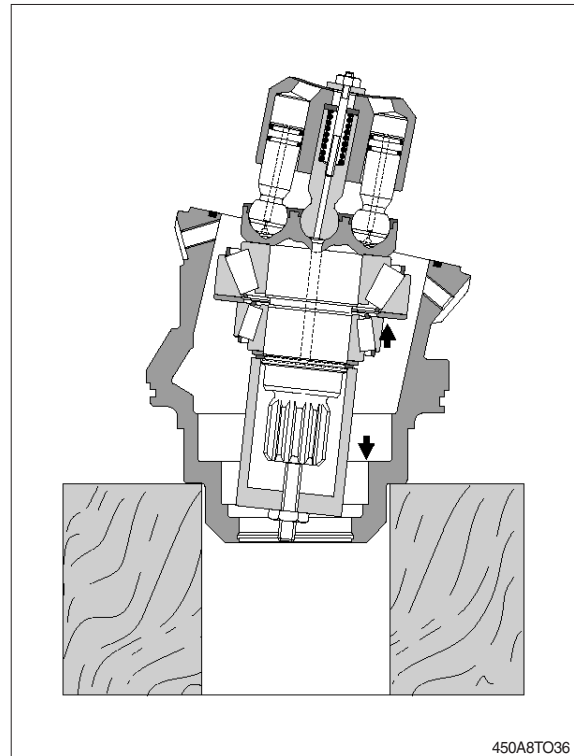

- ⑤ Fix zero position of cylinder with Q_{max} screw.
- a. Disassemble cylinder fixing screw.
 - b. Insert O-ring.

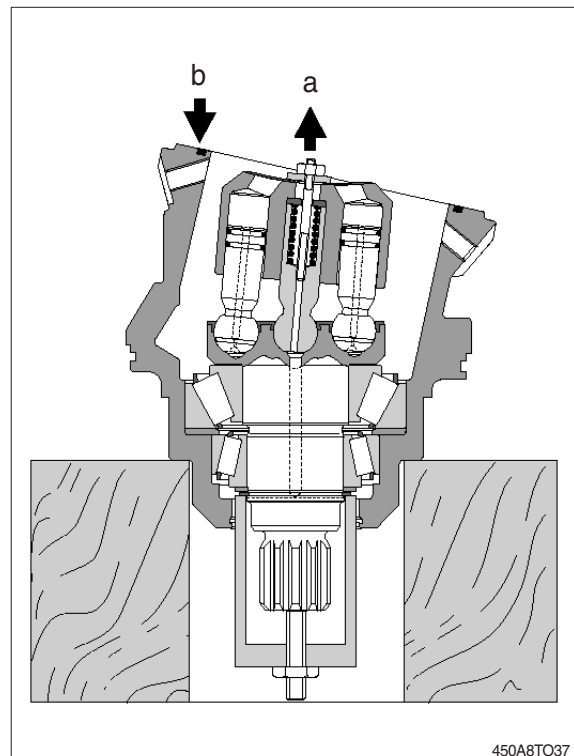

(3) Rotary group adjustment

- ① Determine cylinder swivel range to max angle with screw.

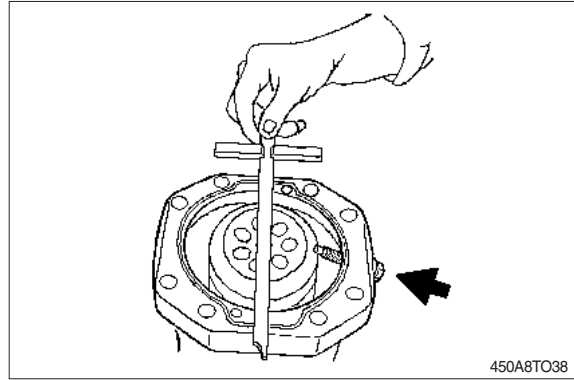

- ② *Disc

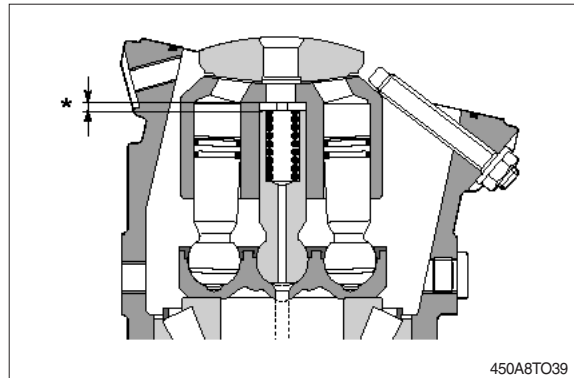

- ③ Place centering disc.

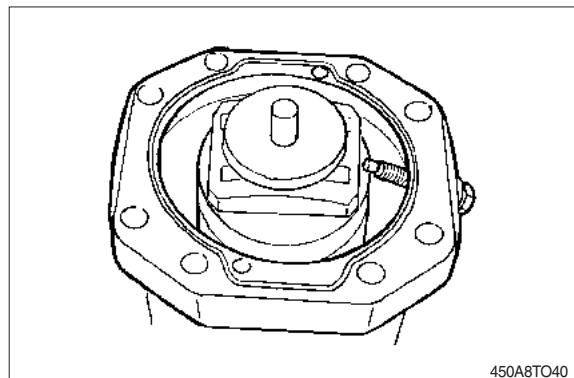

- ④ Mount measuring device.

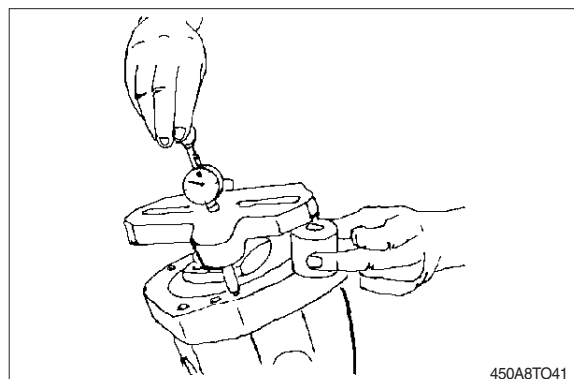

⑤ Check dimension X.

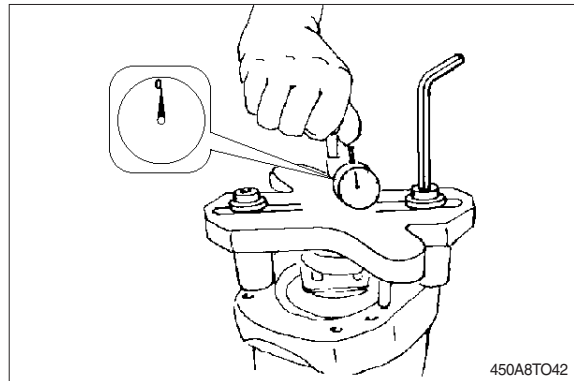

(4) Assembly of the port plate

- ※ Stick control lens in sliding surface with grease. Assembly in reversal order. Mount port plate.

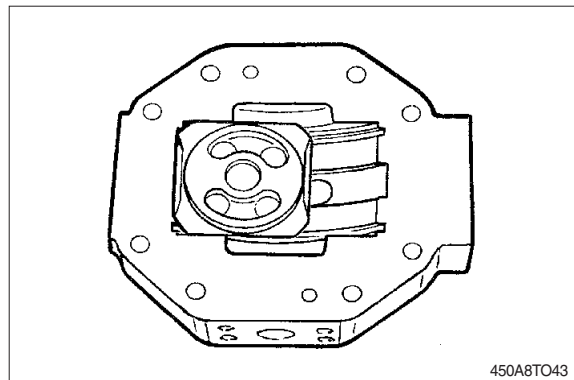

① Assembly port plate.

- ※ Take care of assembly design! Tighten fixing screws with torque.
 - a. Set Q_{min} -screw to dimension*.
 - b. Assemble plug.
 - c. Remove assembly sleeve.

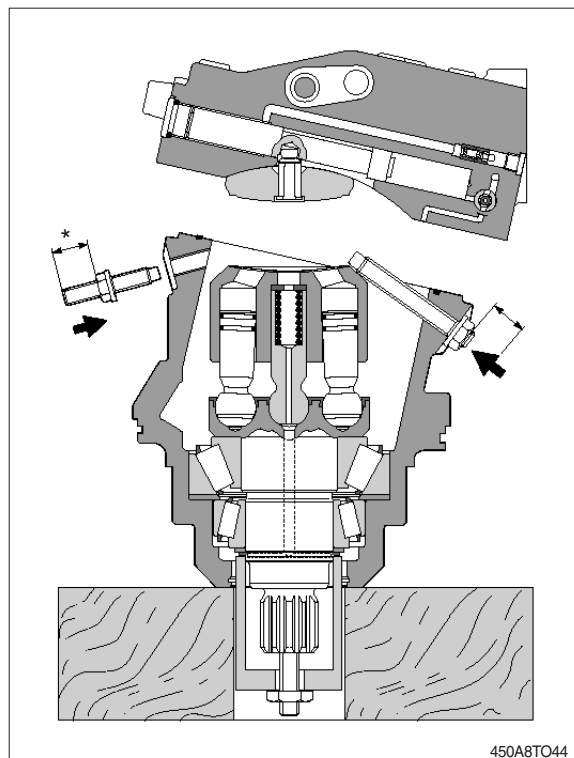

- ② Assemble shaft seal, disc and safety ring. Press-in with assembly sleeve.
※ Take care of press-in depth.

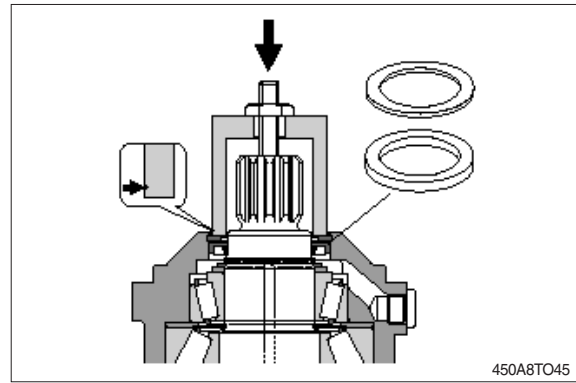

3. REDUCTION GEAR

1) STRUCTURE

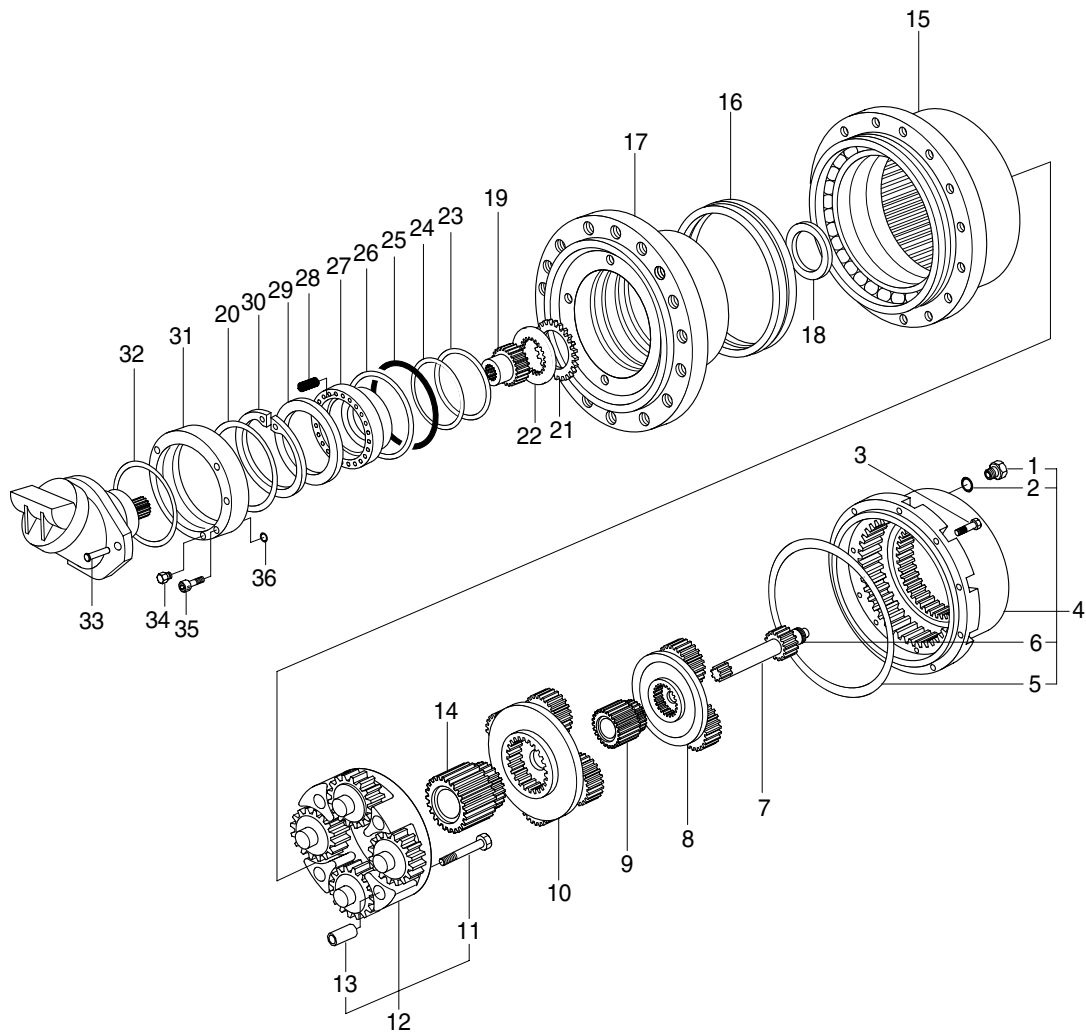

450A8TR01

- | | | | | | |
|----|---------------------|----|---------------|----|-------------|
| 1 | Washer | 13 | Bushing | 25 | O-ring |
| 2 | Breather plug | 14 | Sun gear | 26 | Spiral ring |
| 3 | Screw | 15 | Housing | 27 | Piston |
| 4 | Cover set | 16 | Lifetime seal | 28 | Spring |
| 5 | O-ring | 17 | Hub | 29 | Spacer |
| 6 | Pad | 18 | Spacer | 30 | Circlip |
| 7 | Sun gear | 19 | Brake shaft | 31 | Flange |
| 8 | Reduction assy(1st) | 20 | O-ring | 32 | O-ring |
| 9 | Sun gear | 21 | Brake disc | 33 | Screw |
| 10 | Reduction assy(2nd) | 22 | Steel ring | 34 | Plug |
| 11 | Screw | 23 | Back up ring | 35 | Screw |
| 12 | Reduction assy(3rd) | 24 | O-ring | 36 | O-ring |

2) DISASSEMBLING

Initial inspection of the gears and the travel motor, can be made without disassembling the track and the gearmotor from the machine.

Prior to disassembling make sure that the oil is discharged, unscrew and remove the 2 screws (33), and remove the travel motor and the O-ring (32).

- (1) Unscrew the 8 socket head screws (3) and remove the motor flange from the flanged hub (17).

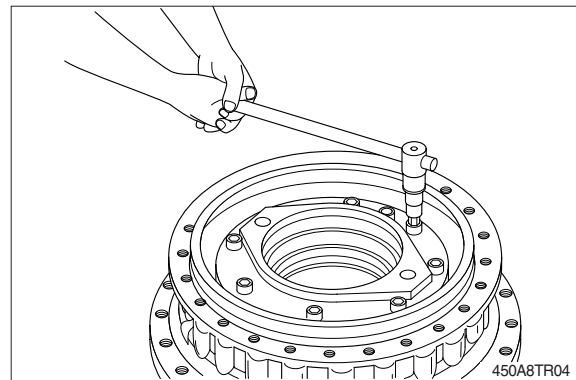

- (2) Remove the O-ring (20) from its groove in the motor flange (31).

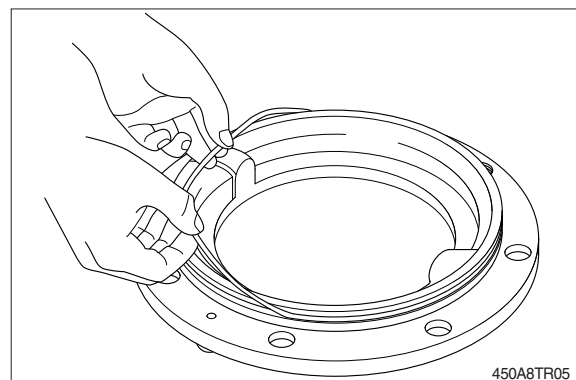

- (3) Remove the O-ring (36) from its groove in the flanged hub (17).

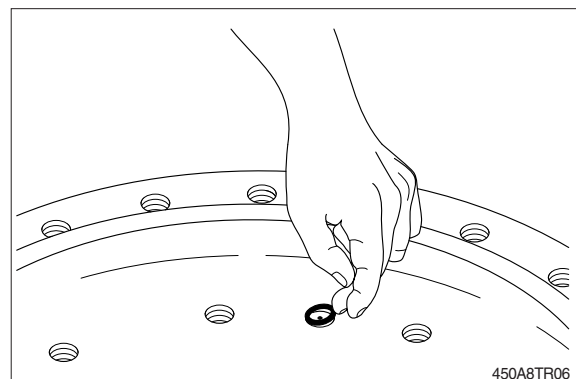

(4) After having placed the disc on the spring retainer (29), fix the pusher on the flanged hub (17) as shown in the scheme by screwing the threaded bar, push the disc on the retainer, thus removing the force of the springs (28) on the circlip (30) and allowing its disassembling.

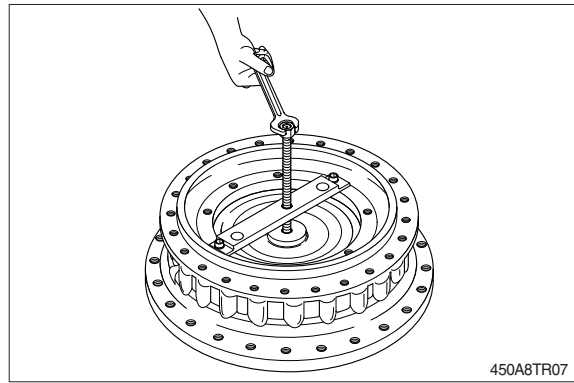

(5) Using pliers remove the circlip (30) from its groove in the flanged hub (17).

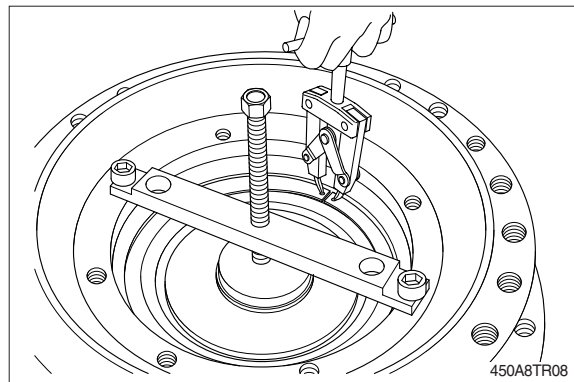

(6) Disassemble the equipment from the flanged hub (17) and remove the circlip (30).

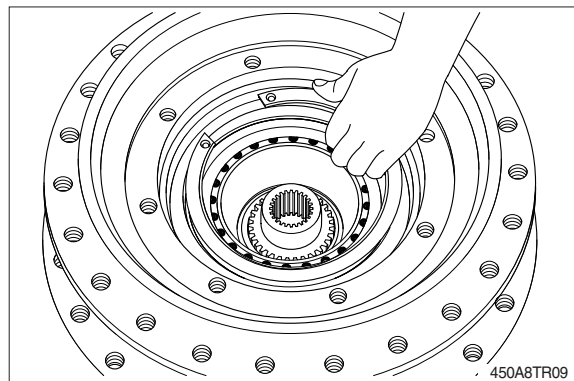

(7) Remove the springs retainer (29).

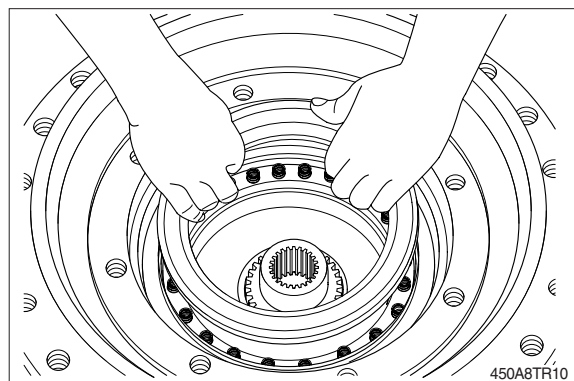

(8) Remove the springs (28) from their grooves.

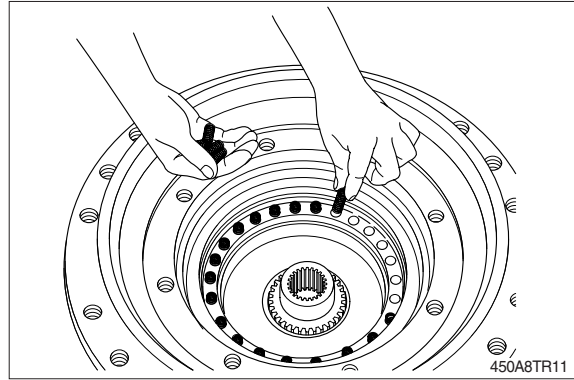

(9) Using pliers remove the brake piston (27).
※ To get it easier, pumping compressed air into the brake port hole.

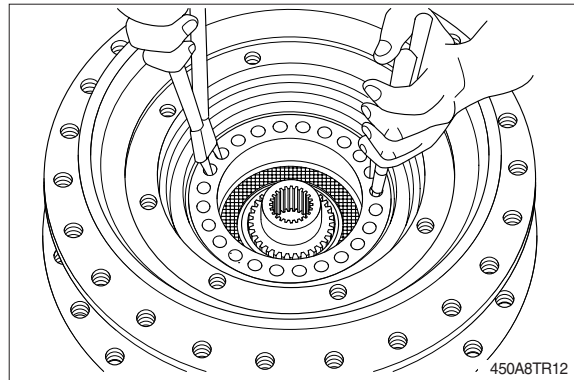

(10) Remove the brake shaft (19).

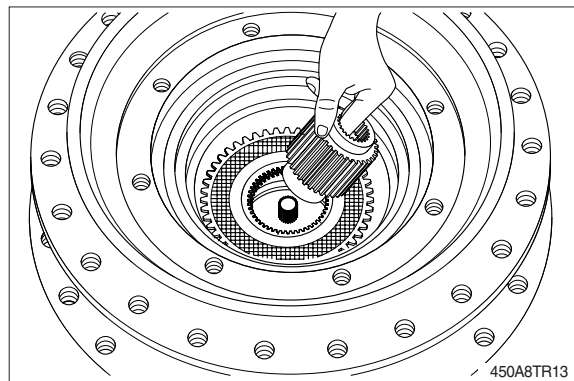

(11) Remove brake discs pack (21, 22).

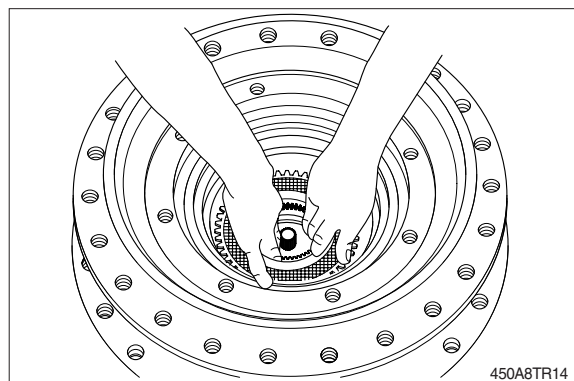

(12) Remove the O-rings (24,25) and the backup rings (23, 26) from their grooves in the flanged hub (17).

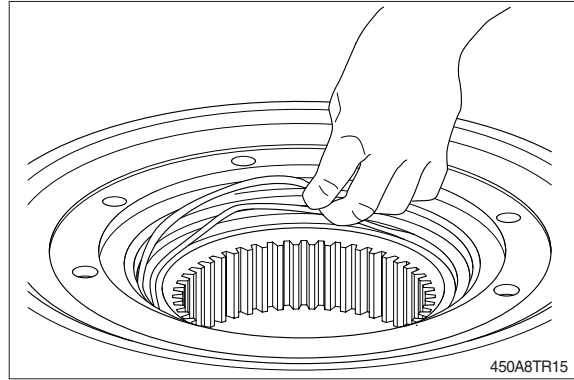

(13) Turn the gearbox around, unscrew and remove the 2 plugs (2) and the 2 washers (1) from the end cover (4).

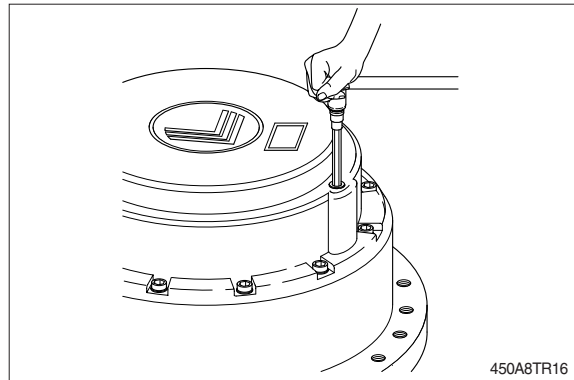

(14) Unscrew and remove the 16 socket head screws (3).

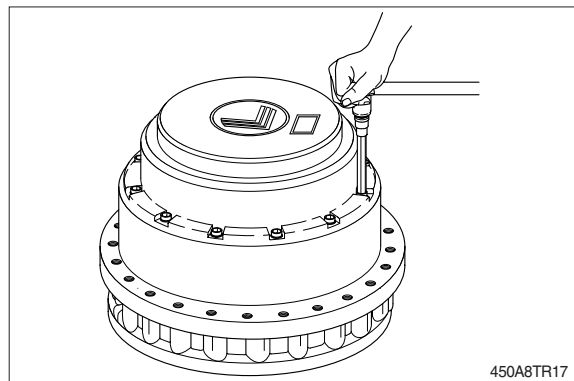

(15) By means of a puller remove the end cover (4).

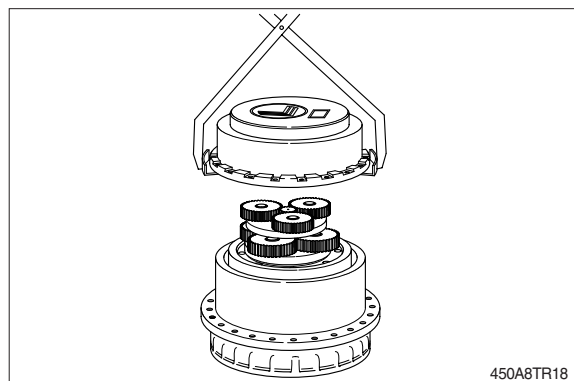

(16) Remove the O-ring (5) from its groove in the end cover (4).

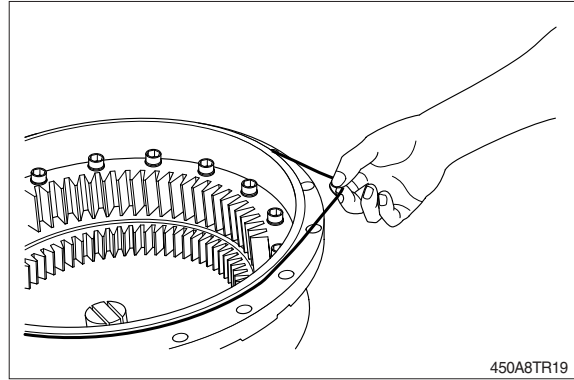

(17) Remove the 1st stage sun gear (7).

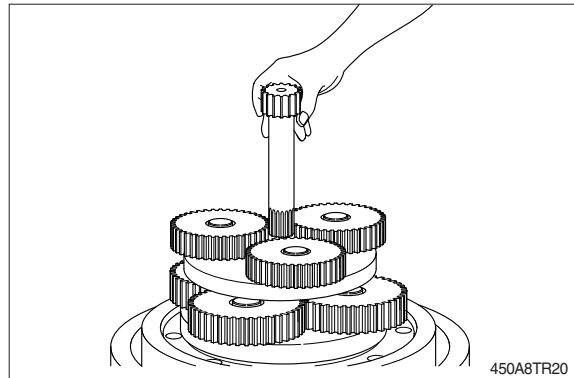

(18) Remove the 1st reduction assembly (8).

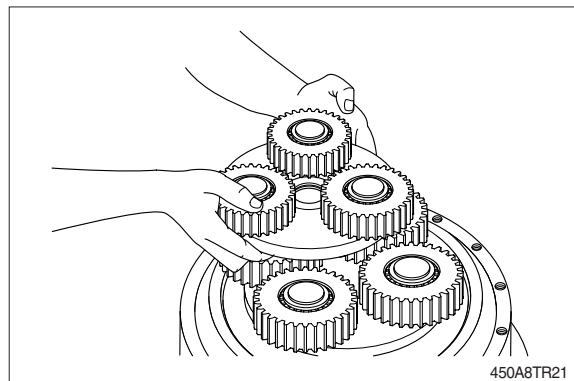

(19) Remove the 2nd stage sun gear (9).

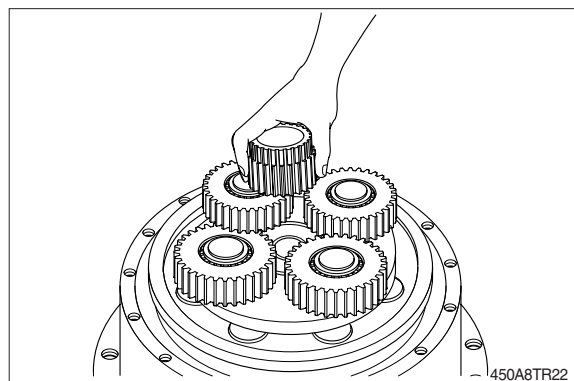

(20) Remove the 2nd reduction assembly (10).

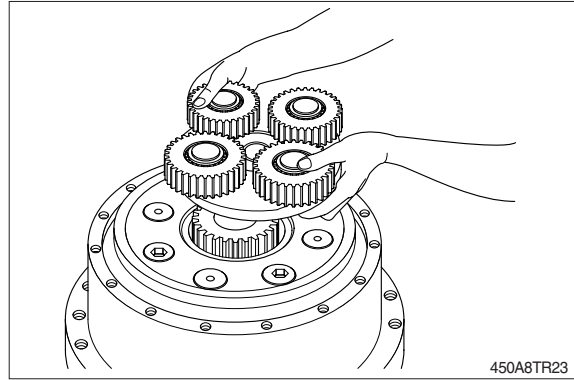

(21) Remove the 3rd stage sun gear (14).

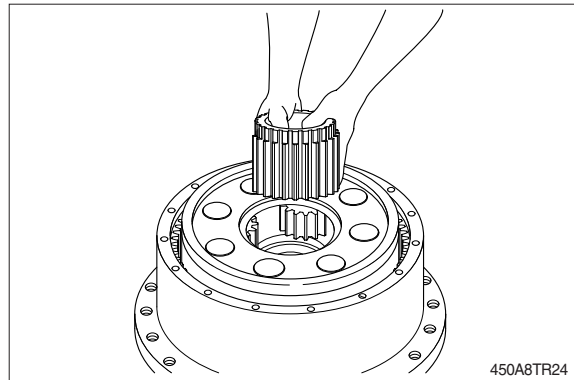

(22) Unscrew the 4 socket head screws (11), fixing the 3rd reduction assembly (12) to the flanged hub (17).

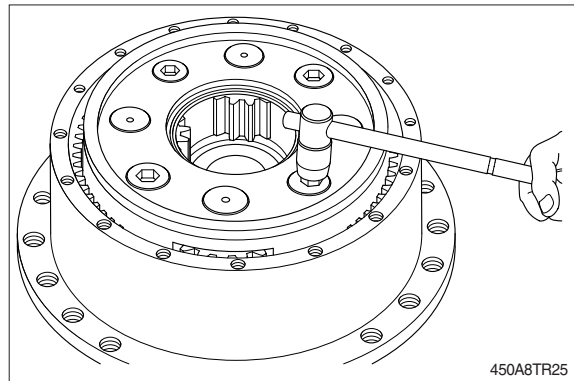

(23) Remove the 4 screws (11).

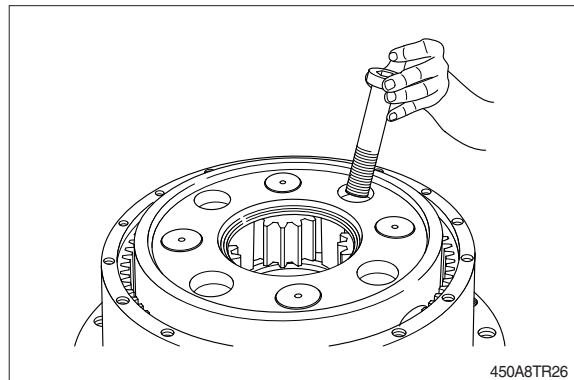

(24) Using a press and a metal stopper, remove the flanged hub (17) from the gearbox housing (14), paying attention to the eventual falling down of the main bearing's balls.

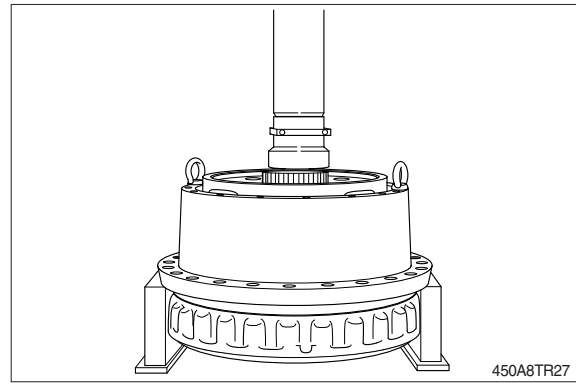

(25) Remove the 3rd reduction assembly (12) from the flanged hub (17).

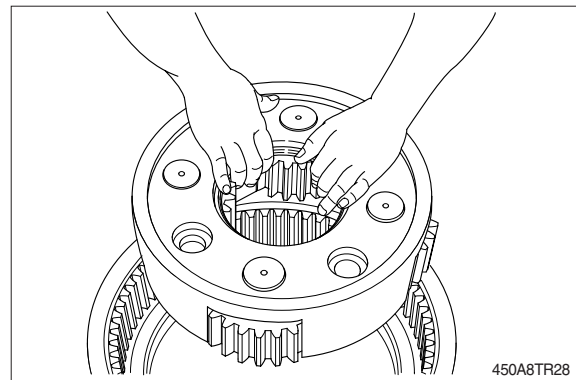

(26) Using the equipment, remove bushes (13) from the flanged hub (17).

- ※ It is possible that the planet assemblies (see reassembly (11)) remain assembled to the planet-carrier. In this case it is sufficient to push on them by means of a rubber pad or a press.
- In case the planet assemblies remain assembled to the flanged hub, it is better to use the fixture (for this operation).

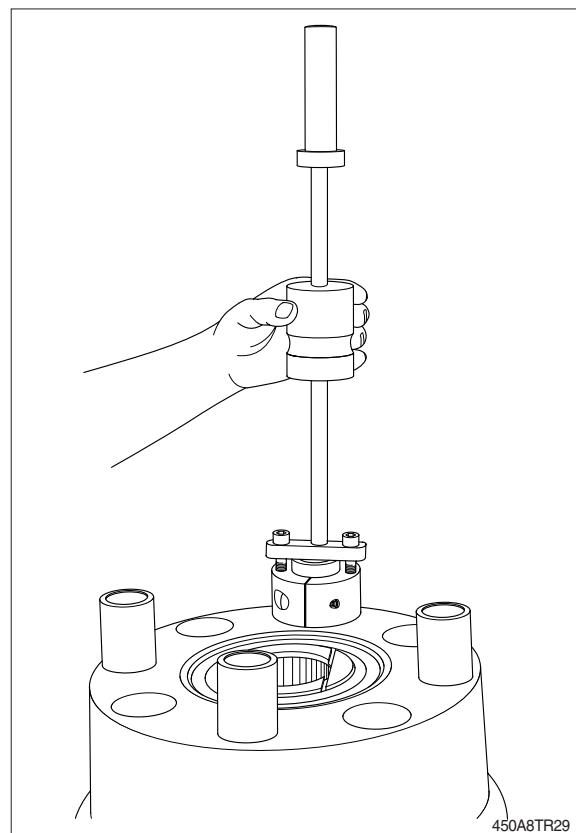

(27) By means of an extractor, remove the inner race of the bearing and spacer kept on the flanged hub (17).

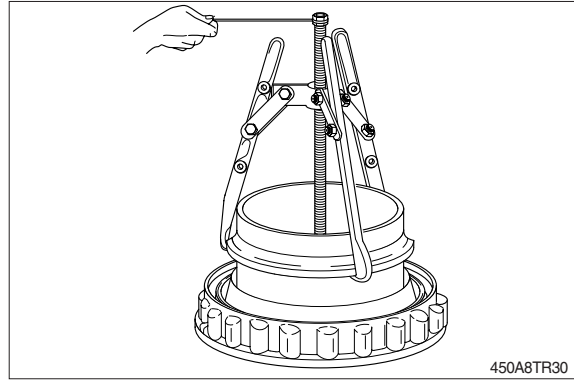

(28) Withdraw both the half-seals (16) from the flanged hub (17) and from the gearbox housing (15).

※ Lifetime seal check

In case of oil leakages, it should be necessary to check and eventually replace the lifetime seal (16), which means both the metal rings parts and the O-rings. In this case it is necessary to disassemble the gearbox from the machine.

※ The gearbox disassembly ends with the above operation: All items are now available for the necessary checks.

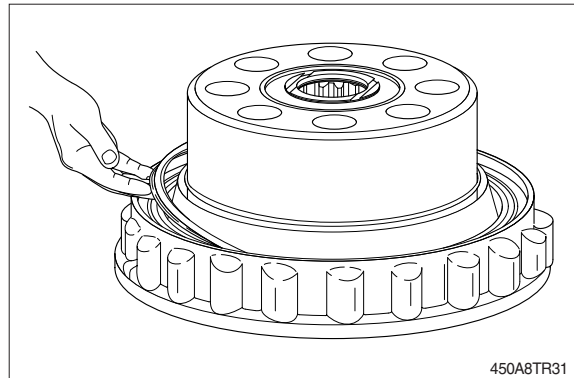

3) REASSEMBLY

※ For the correct assemble of gearbox please follow these basic instructions:

In case of damaged gears, for example a planetary, replace all the reduction assembly and not only the damaged gear.

※ Before reassembling the O-ring, gaskets and the oil seals:

Concerned should be removed.

Clean with care all the housing of the seal and put some grease on the gasket before mounting.

※ Never change only one part of the lifetime seal, always the two rings together.

(1) Fit the half seals (16) on the tool.

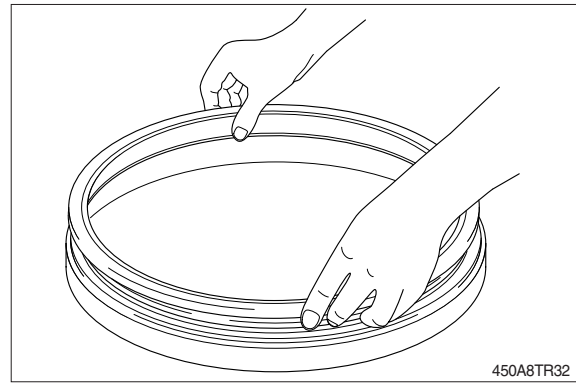

(2) Fit the half seals (16) inside the gearbox housing (15).

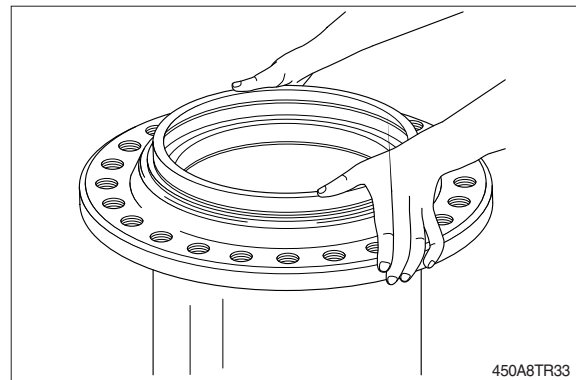

(3) Clean carefully the metallic face of the half-seal.

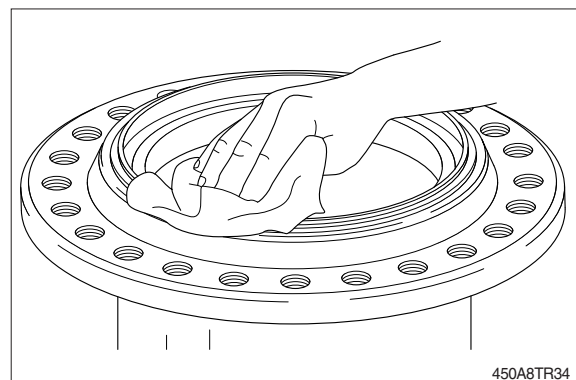

(4) Assemble, by using the same tool, the half seal (16) on the flanged hub (17).

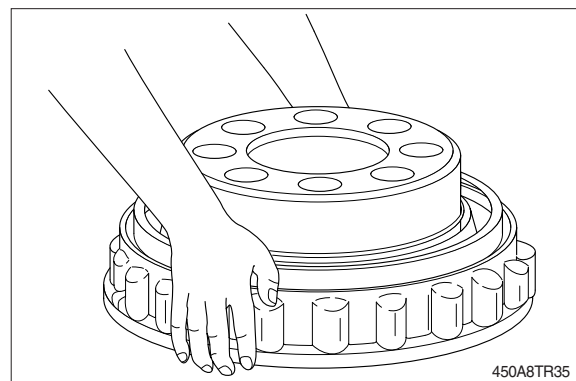

- (5) Lube the metallic face of the half seal with a thin oil film.

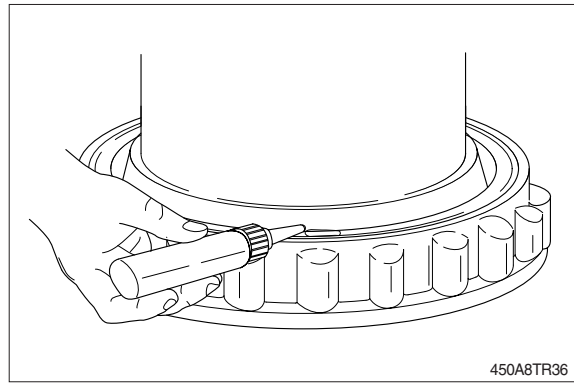

- (6) Fit on the housing the lower ball row, withstanding the ball race through the spacers 1 and 2.
Between the balls, insert the proper spacers.

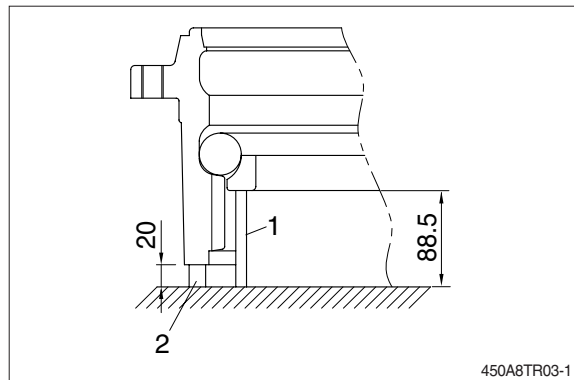

- (7) After having placed the bearing spacer fit the upper ball row.
Then place the upper inner race.

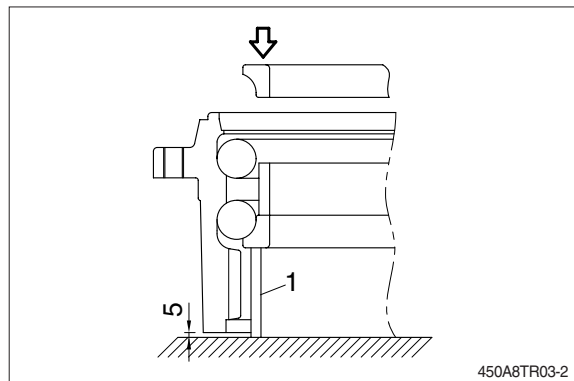

- (8) Lift the flanged hub (17) then lower it inside the gearbox housing (15).

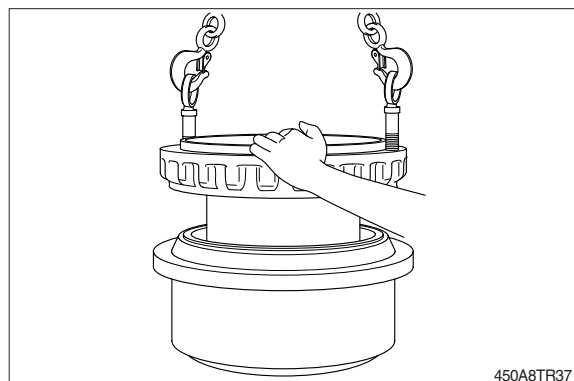

(9) Using a press and a metal stopper, push the flanged hub (17) against the shoulder on the gearbox housing (15) until assembling is complete.

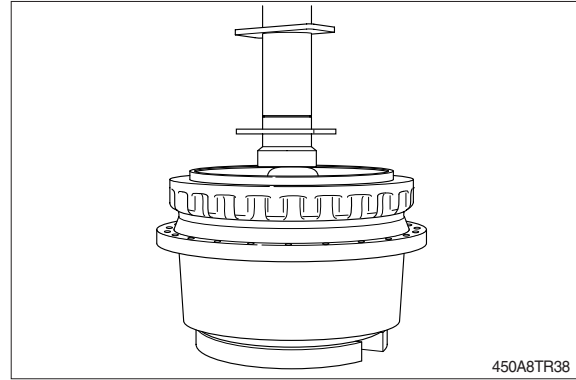

(10) Using a press, place and push the 4 bush, inside their seats on the flanged hub (17).

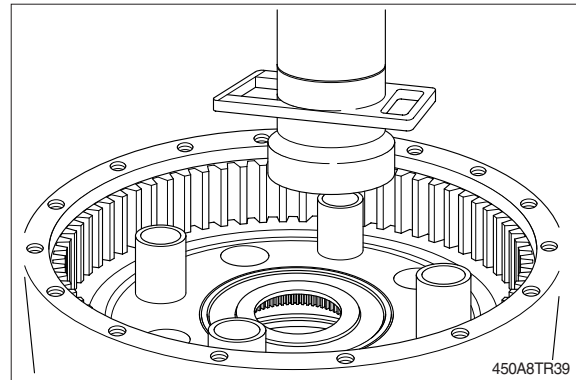

(11) View of the 3rd reduction's planet assembly.

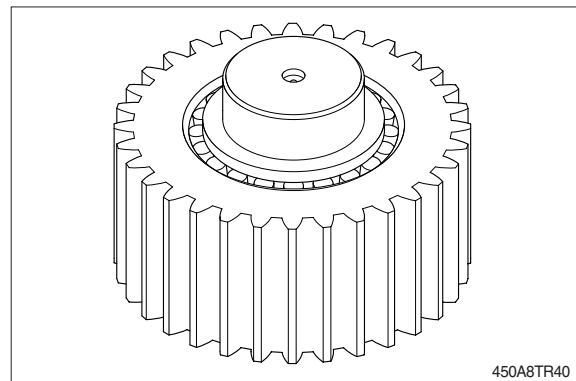

(12) Using a press push the 4 planet assemblies against the shoulder on the flanged hub (17).

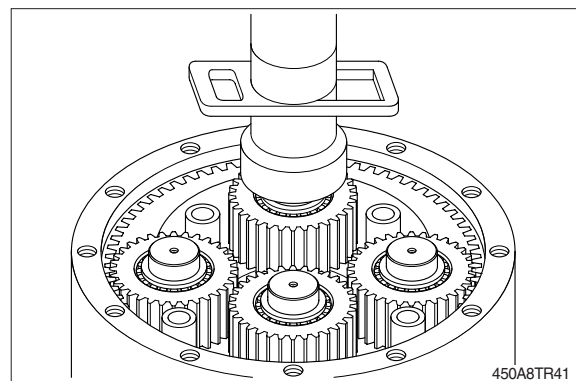

(13) Place the 3rd reduction planet carrier on the hub (17).

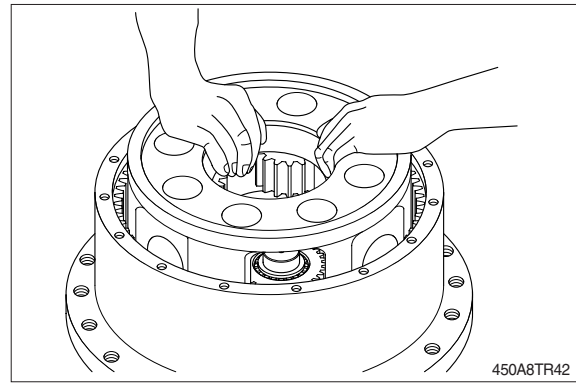

(14) Using a press push the 3rd reduction planet carrier against the shoulder on the flanged hub (17) until complete assembly.

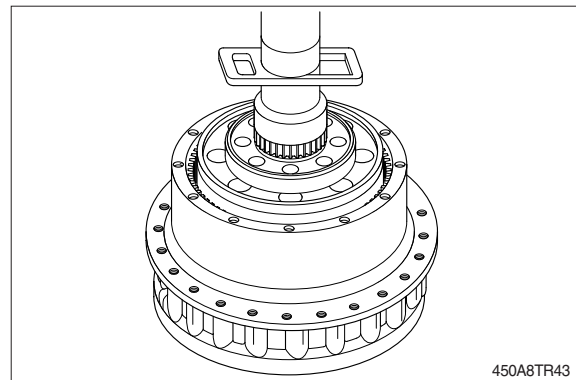

(15) Apply LOCTITE type 243 on the 4 socket head screws (11), and insert them in the thread holes.

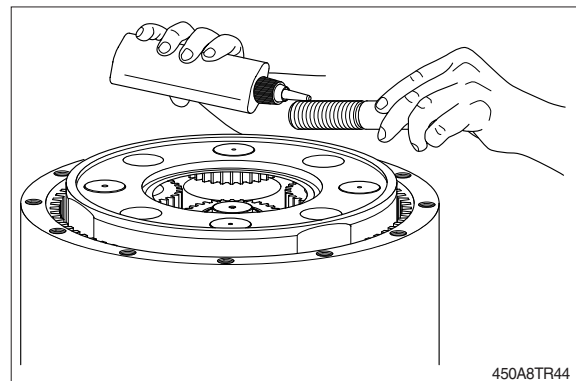

(16) Tighten the screws by a torque wrench at a torque of $153\text{kgf} \cdot \text{m}$ ($1107\text{lb} \cdot \text{ft}$), locking the gearbox acting with the press on a 3rd reduction's planet.

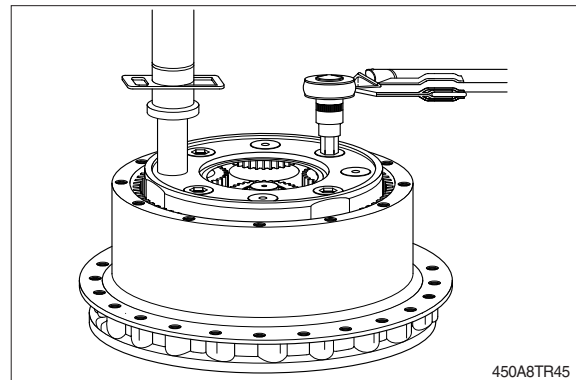

(17) Insert the 3rd stage sun gear (14).

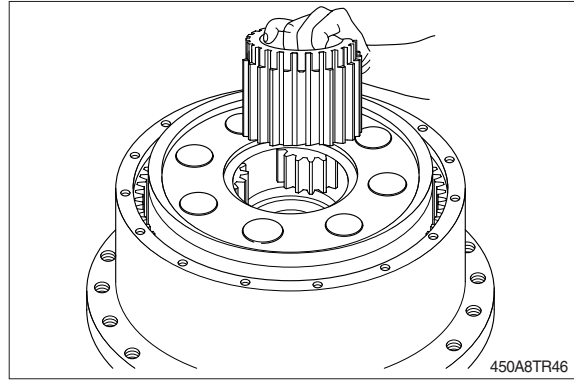

(18) Insert the 2nd reduction assembly (10).

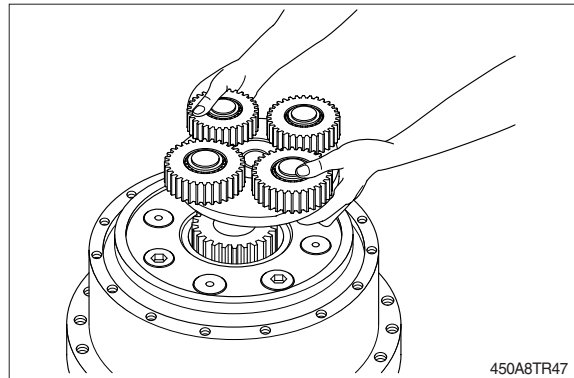

(19) Insert the 2nd stage sun gear (9).

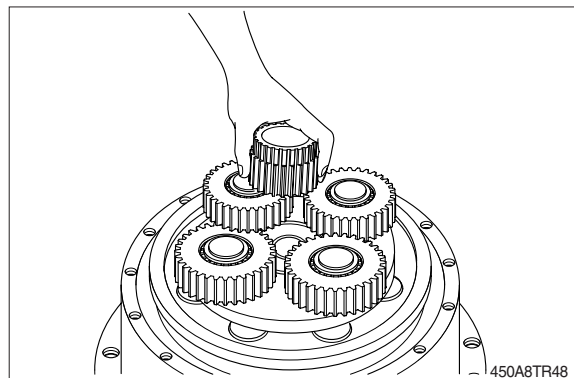

(20) Insert the 1st reduction assembly (8).

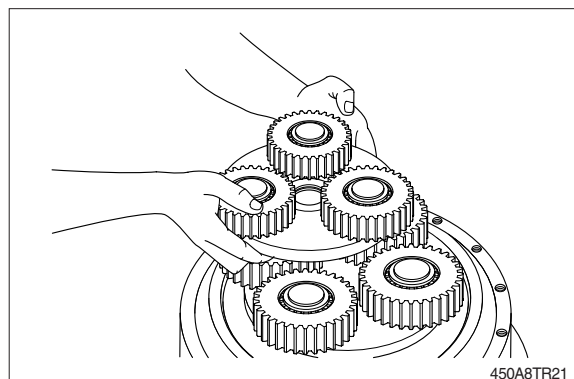

(21) Insert the 1st stage sun gear (7).

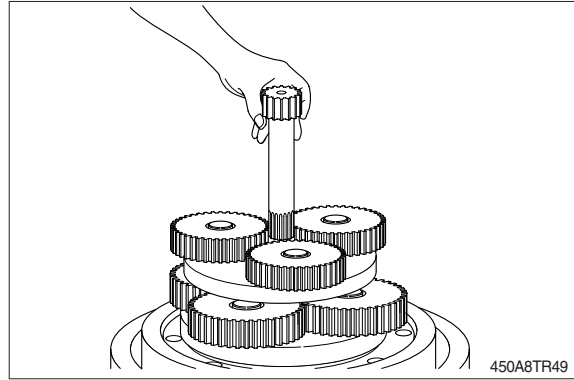

(22) Fit the O-ring (5) into its groove in the end cover (4).

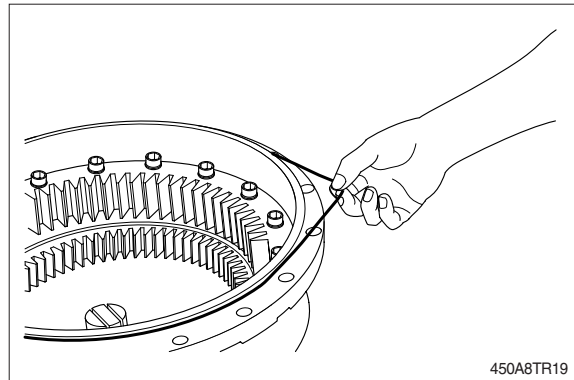

(23) Place the end cover (4) on the gearbox housing (15).

Apply LOCTITE type 243 on the 16 socket head screws (3), and tighten them by a torque wrench at a torque of 19.4 kgf · m (140 lbf · ft).

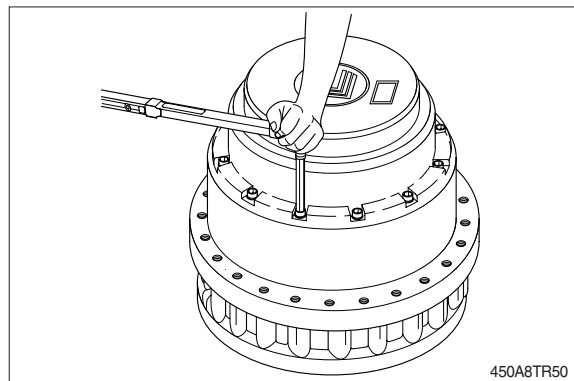

(24) Place the 2 washer (1) in their groves and tighten the 2 plugs at a torque of 6.1~8.2 kgf · m (44.1~59.3 lbf · ft).

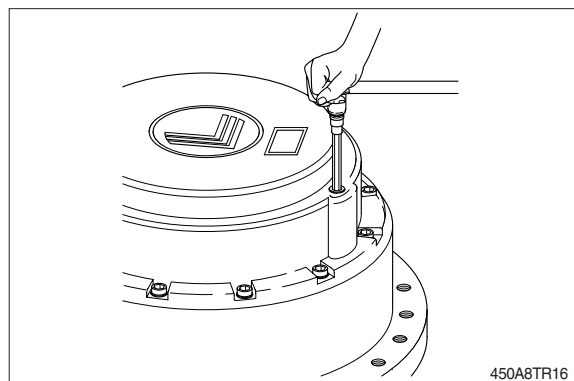

(25) Turn the gearbox around and insert the brake shaft (19).

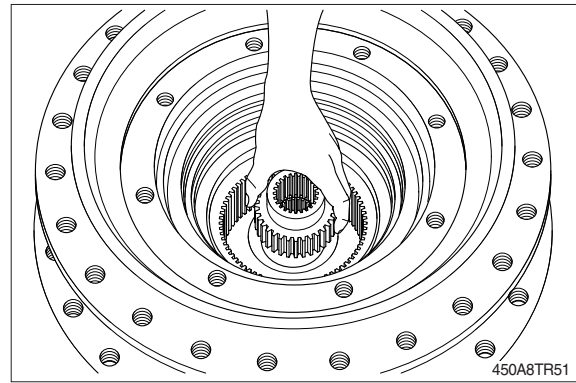

(26) View of the brake discs (21, 22).

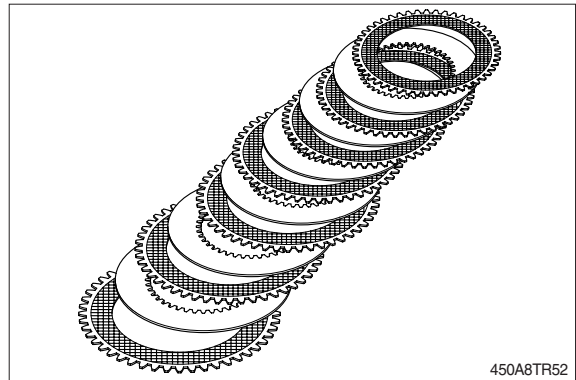

(27) Assemble the brake discs package according to the following order: Firstly insert an external toothed sintered bronze disc (21). Then insert, an internal toothed steel disc (22). Repete the operation until reaching the number of 7 bronze and 6 steel discs.

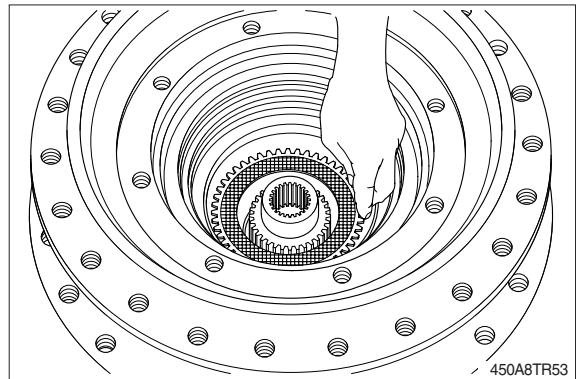

(28) Fit the backup rings (23, 26) and the O-rings (24, 25) inside the two internal grooves of the flanged hub (17, see drawing).

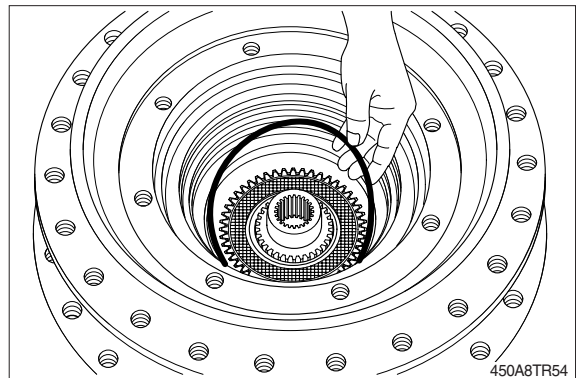

- ※ An O-ring and a backup ring must be fitted in the groove paying attention that the backup ring must always be beyond the O-ring against the oil flow.

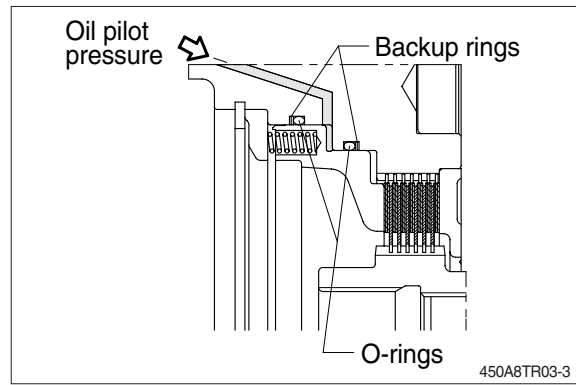

- (29) Insert the brake piston (27) inside the flanged hub (17), paying attention not to damage the seals already fitted.

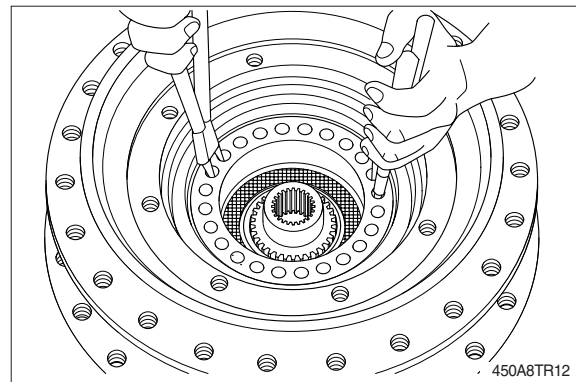

- (30) Insert the springs (28) into the grooves in the brake piston (27).

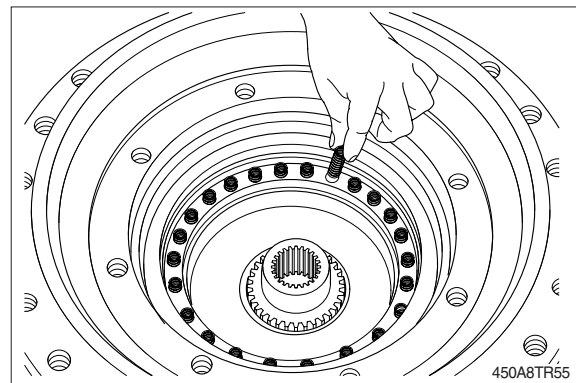

- (31) Insert the retainer disc (29).

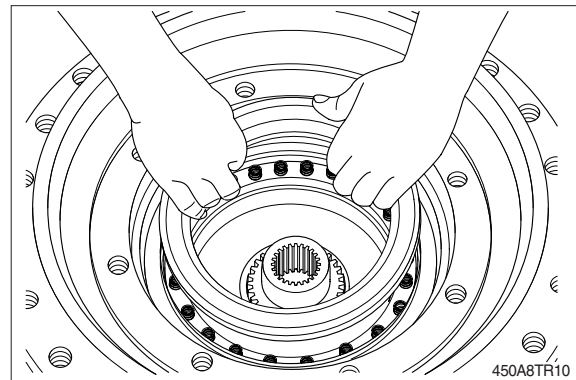

(32) Fixed the equipment to the flanged hub (17) and screw the threaded screw up the springs retainer disc (29) is lowered below the circlip seat (30).

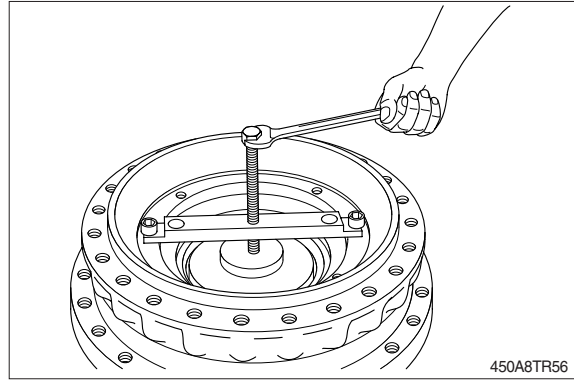

(33) By means of pliers, place the circlip (30) into its groove.

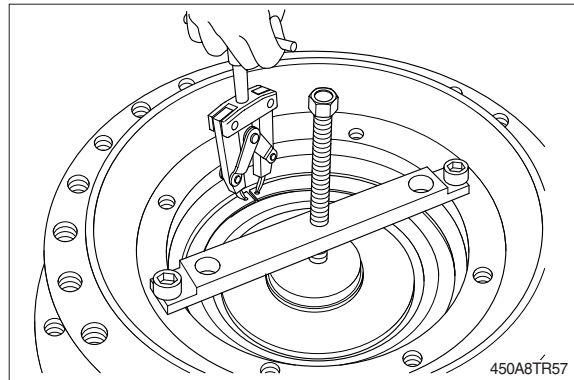

(34) Fit the O-ring (36) into its groove in the flanged hub (17).

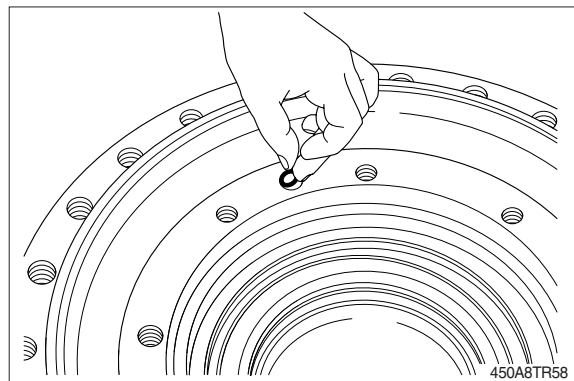

(35) Fit the O-ring (20) into the groove of the motor flange (32).

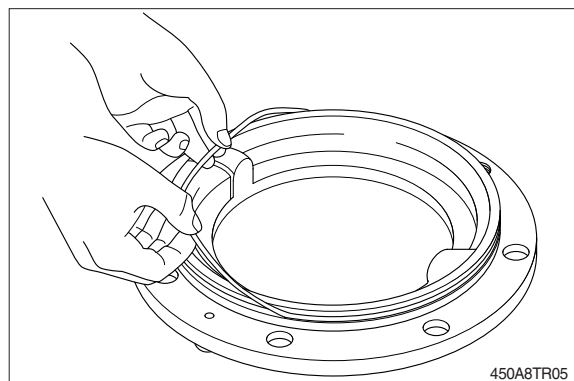

(36) Place and fix the motor flange (32) to the flanged hub (17) through 8 screws (35) tightened by a torque wrench at a torque of 21.9 kgf · m (158.4 lbf · ft).

※ After having reassembled the gearbox, fit the travel motor (taking care to include the O-ring(32), by means of 2 fixing screws(33), tightened at 42.3kgf · m (306.0lbf · ft). Fill the gearbox with the lubricant oil.

