

GROUP 2 MAJOR COMPONENT

1. MAIN PUMP

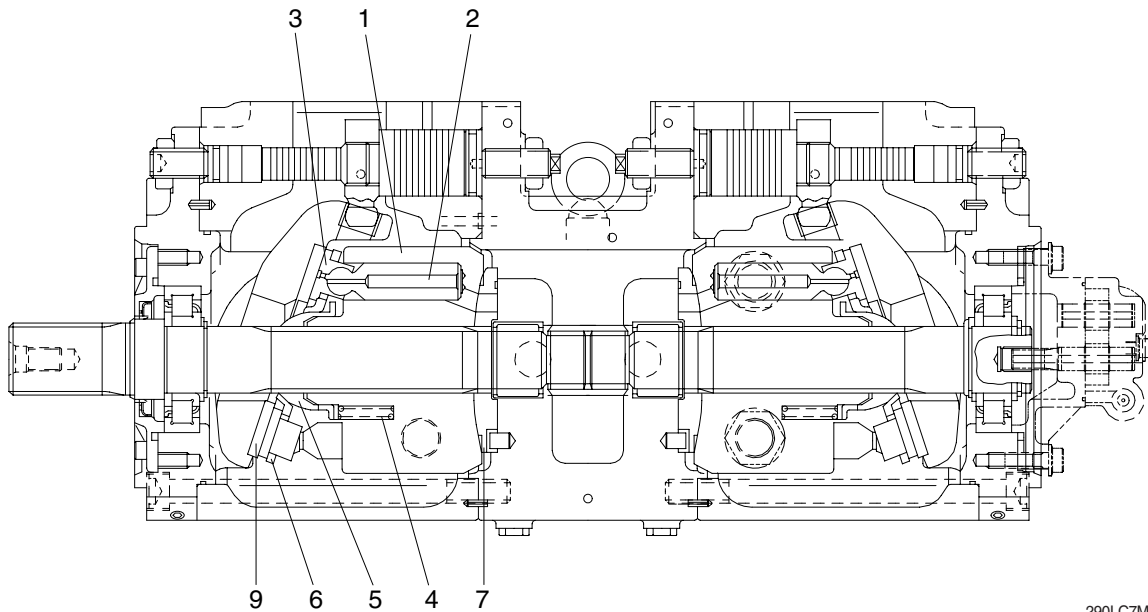
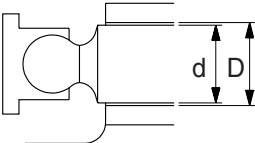
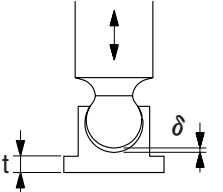
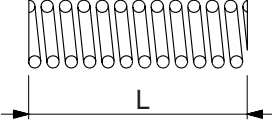
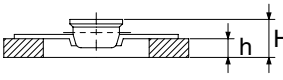

290LC7MS08

Part name & inspection item		Standard dimension	Recommended replacement value	Counter measures
Clearance between piston(1) & cylinder bore(2) (D-d)		0.043	0.070	Replace piston or cylinder.
Play between piston(1) & shoe caulking section(3) (δ)		0-0.1	0.3	Replace assembly of piston & shoe.
Thickness of shoe (t)		5.4	5.0	
Free height of cylinder spring(4) (L)		47.9	47.1	Replace cylinder spring.
Combined height of set plate(5) & spherical bushing(6) (H-h)		23.8	22.8	Replace retainer or set plate.
Surface roughness for valve plate (sliding face) (7,8), swash plate (shoe plate area) (9), & cylinder(2) (sliding face)	Surface roughness necessary to be corrected	3z		Lapping
	Standard surface roughness (corrected value)	0.4z or lower		

2. MAIN CONTROL VALVE

Part name	Inspection item	Criteria & measure
Casing	<ul style="list-style-type: none"> Existence of scratch, rusting or corrosion. 	<ul style="list-style-type: none"> In case of damage in following section, replace part. Sliding sections of casing fore and spool, especially land sections applied with holded pressure. Seal pocket section where spool is inserted. Sealing section of port where O-ring contacts. Sealing section of each relief valve for main, travel and port. Other damages that may damage normal functions.
Spool	<ul style="list-style-type: none"> Existence of scratch, gnawing, rusting or corrosion. O-ring seal sections at both ends. Insert spool into casing hole, rotate and reciprocate it. 	<ul style="list-style-type: none"> Replacement when its outside sliding section has scratch (especially on seals-contacting section). Replacement when its sliding section has scratch. Correction or replacement when O-ring is damaged or when spool does not move smoothly.
Poppet	<ul style="list-style-type: none"> Damage of poppet or spring. Insert poppet into casing and function it. 	<ul style="list-style-type: none"> Correction or replacement when sealing is incomplete. Normal when it can function lightly without being caught.
Around spring	<ul style="list-style-type: none"> Rusting, corrosion, deformation or breaking of spring, spring seat, plug or cover. 	<ul style="list-style-type: none"> Replacement for significant damage.
Around seal for spool	<ul style="list-style-type: none"> External oil leakage. Rusting, corrosion or deformation of seal plate. 	<ul style="list-style-type: none"> Correction or replacement. Correction or replacement.
Main relief valve, port relief valve & negative control relief valve	<ul style="list-style-type: none"> External rusting or damage. Contacting face of valve seat. Contacting face of poppet. Abnormal spring. O-rings, back up rings and seals. 	<ul style="list-style-type: none"> Replacement. Replacement when damaged. Replacement when damaged. Replacement. 100% replacement in general.

3. SWING DEVICE

1) WEARING PARTS

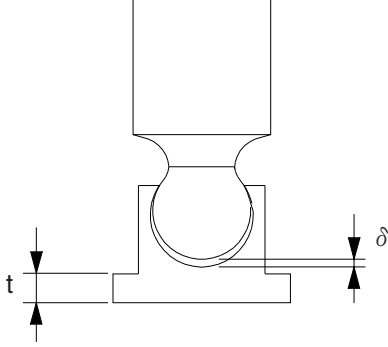
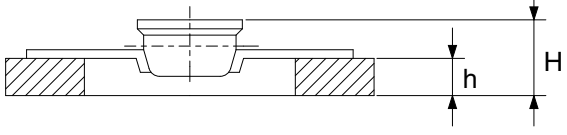
Inspection item	Standard dimension	Recommended replacement value	Counter measures
Clearance between piston and cylinder block bore	0.028	0.058	Replace piston or cylinder block
Play between piston and shoe caulking section (δ)	0	0.3	Replace assembly of piston and shoe
Thickness of shoe (t)	5.5	5.3	Replace assembly of piston and shoe
Combined height of retainer plate and spherical bushing (H-h)	6.5	6.0	Replace set of retainer plate and spherical bushing
Thickness of friction plate	4.0	3.6	Replace
			

2) SLIDING PARTS

Part name	Standard roughness	Allowable roughness	Remark
Shoe	0.8-Z (Ra=0.2) (LAPPING)	3-Z (Ra=0.8)	
Shoe plate	0.4-Z (Ra=0.1) (LAPPING)	3-Z (Ra=0.8)	
Cylinder	1.6-Z (Ra=0.4) (LAPPING)	12.5-Z (Ra=3.2)	
Valve plate	0.8-Z (Ra=0.2) (LAPPING)	6.3-Z (Ra=1.6)	

4. TRAVEL MOTOR (TYPE 1)

- 1) Free of corrosion, erosion or fretting; no damage to splines or keyways.

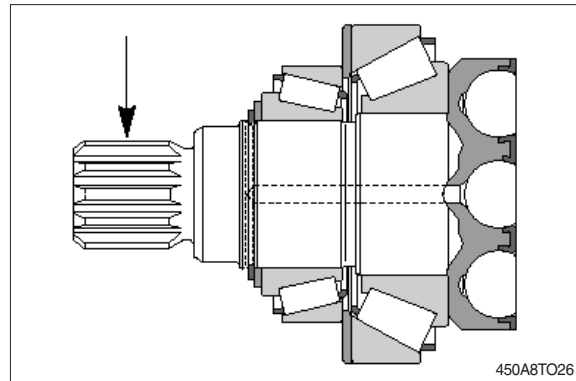

- 2) Pistons
No scoring and no pittings.

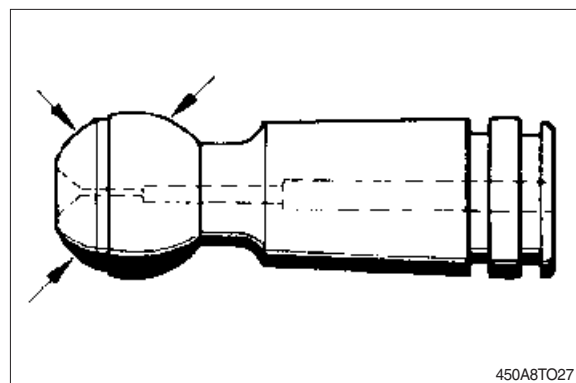

- 3) Center pin
No scoring and no pittings.

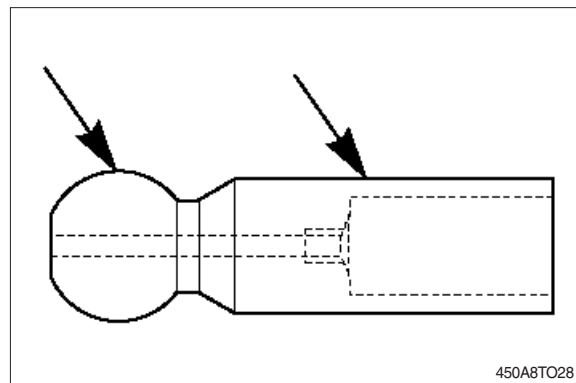

- 4) Retaining plate
No scoring and no evidence of wear.

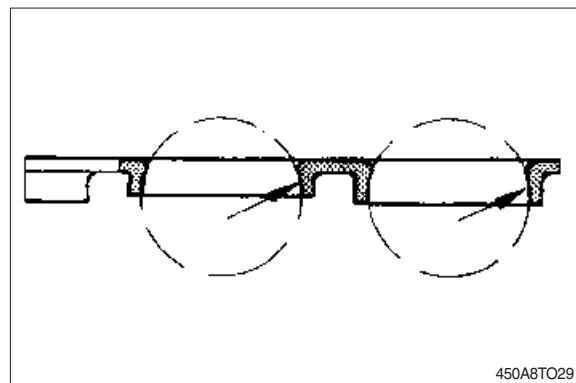

5) Cylinder block / control lens

a : Bores free of scoring, no evidence of wear.

b : Faces smooth and even, free of cracks and scoring.

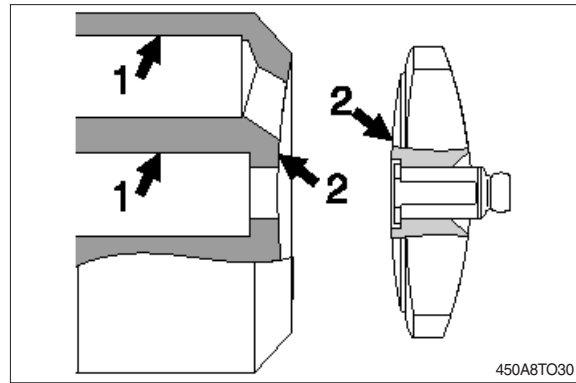

6) Control housing

Sliding surface and side guides free of scoring and no wear.

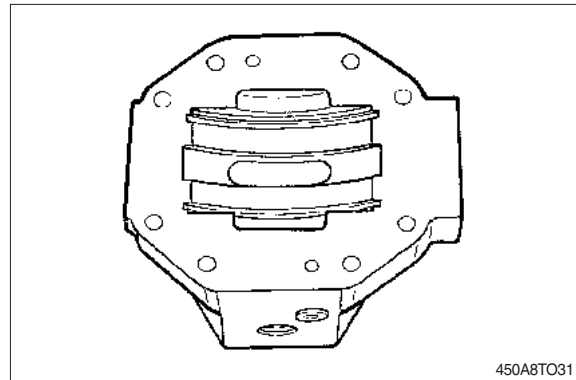

7) Visual check : Bearing areas free of scoring and no evidence of wear.

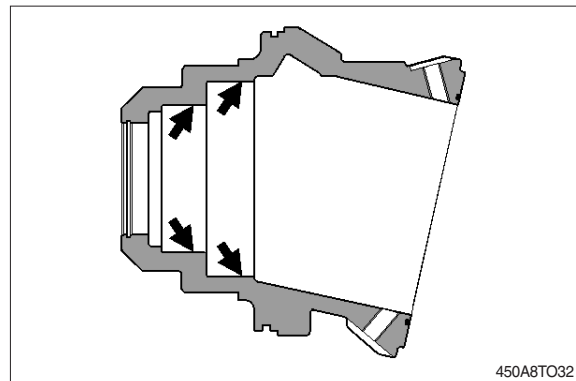

4. TRAVEL MOTOR (TYPE 2)

Replace parts in accordance with the following standards. However, if a part is damaged significantly in terms of its appearance, replace it irrespective of the standards.

1) HYDRAULIC MOTOR

Part name & inspection item	Standard dimension	Recommended value for replacement	Remedy
Clearance between piston & cylinder bore (D-d)	0.052 mm	0.077 mm	Replacement
Clearance caulked part between piston and shoe (δ)	0.1 mm	0.3 mm	Replacement
Thickness of shoe	7.5 mm	7.3 mm	Replacement
Assembled height of spherical bush and set plate (H-h)	26.5 mm	26.0 mm	Replacement as a set
Free length of cylinder spring	68.0 mm	67.4 mm	Replacement
Shaft over pin dia. Output spline Cylinder spline	51.402 (\varnothing 4.5) 58.878 (\varnothing 4.5)	52.002 mm 59.478 mm	Replacement if either one reaches replacement value.
Spline over dia. Spline in cylinder Spline in spherical bushing	42.302 (\varnothing 6)	42.902 mm	Replacement
Thickness of separation plate Thickness of friction plate	2.43 mm 3.9 mm	2.23 mm 3.7 mm	Replacement
Free length of brake spring	39.77 mm	38.77 mm	Replacement
Displacement over teeth Over pin dia. of friction plate internal teeth	68.77 (8teeth) 173.67 (\varnothing 5)	68.47 mm 174.27 mm	Replacement Replacement
Roughness of sliding surfaces Swash plate/shoe Cylinder block/valve plate	0.4 - z 0.4 - z	3 - z 3 - z	Each independent lapping Mutual lapping
Roller bearing Needle bearing	-	-	Replacement if flaking is found on rolling surface.
O-ring Oil seal	-	-	Replacement at every disassembly, in principle.

Part name & inspection item	Standard dimension	Recommended value for replacement	Remedy
Bolt	-	-	Replacement if elongation is found.

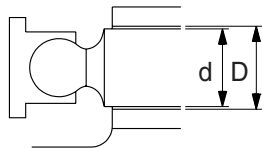

clearance between piston
and cylinder bore : $D-d$

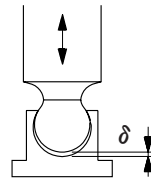

Play at caulking between piston and shoe : δ

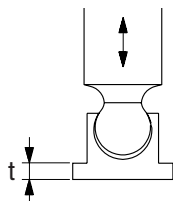

Thickness of shoe : t

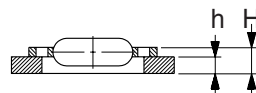

Assembled height of set plate
and spherical bushing : $H-h$

2) REDUCTION GEAR

Part name & inspection item	Standard dimension	Recommended value for replacement	Remedy
Pitting or crack of gear	-	Pitting area rate : 10%	Replacement pitting or crack is found
Motor driving gear external spline	Overpin 51.402(ø 4.5)	52.002 mm	(Z=14)
Drive gear internal spline	Overpin 51.491 (ø 4.5)	52.091 mm	Replacement (Z=17)
No. 1 planetary gear	Displacement 48.352 (4EA)	48.052 mm	Replacement (Z=26)
No. 1 carrier internal spline	Overpin 108.01 (ø 13)	108.61 mm	Replacement (Z=21)
No. 2 sun gear	Displacement 65.555 (4EA)	65.255 mm	Replacement (Z=21)
No. 2 planetary gear	Displacement 64.724 (5EA)	64.424 mm	Replacement (Z=23)
No. 2 carrier internal spline	Overpin 119.97 (ø 13)	120.57 mm	Replacement (Z=23)
Ring gear	Overpin 399.97 (ø 10.3)	400.57 mm	Replacement (Z=69)
No. 3 sun gear	Displacement 65.881 (4EA)	65.581 mm	Replacement (Z=23)
No. 3 planetary gear	Displacement 47.474 (3EA)	47.174 mm	Replacement (Z=22)
No. 3 carrier internal spline	Overpin 161.24 (ø 7.5)	161.84 mm	Replacement (Z=45)
Cover internal gear	Overpin 345.0 (ø 7.7)	345.60 mm	Replacement (Z=79)
Crack and flaking of bearing inner/outer races and rollers	-	-	Replacement if crack or flaking is found.
Crack and flaking of 1st/2nd/3rd planetary gears and pins	-	-	Replacement if crack or flaking is found.
Radial clearance of needle bearing	0.01-0.04 mm	0.07 mm	Replacement as a set.
Crack of spline contact part	-	-	Replacement if crack or flaking is found.

Part name & inspection item	Standard dimension	Recommended value for replacement	Remedy
Backlash of spline contact part	0.1-0.3 mm	0.5 mm	Replacement as a recommended value for replacement.
Thrust ring 90	Thickness 8 mm	7.6 mm	Replacement if severe wear or seizure is found on sliding surface.
Floating seal	-	-	Replacement of scratch or rust is found in sliding surface. Replacement if O-ring is deformed or damaged.
Gear oil	-	-	1st time : 500hr 2nd time and later : Every 2000hr After disassembling, fill with new oil without fail. (The above times are measured with engine hour meter.)

5. RCV LEVER

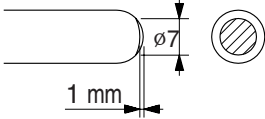
Maintenance check item	Criteria	Remark
Leakage	The valve is to be replaced when the leakage becomes more than 1000cc/m at neutral handle position, or more than 2000cc/m during operation.	Conditions : Primary pressure : 30 kgf/cm ² Oil viscosity : 23cSt
Spool	This is to be replaced when the sliding surface has worn more than 10μm, compared with the non-sliding surface.	The leakage at the left condition is estimated to be nearly equal to the above leakage.
Push rod	 <p>This is to be replaced when the top end has worn more than 1mm.</p>	
Play at operating section	The pin, shaft, and joint of the operating section are to be replaced when their plays become more than 2mm due to wears or so on.	When a play is due to looseness of a tightened section, adjust it.
Operation stability	When abnormal noises, hunting, primary pressure drop, etc. are generated during operation, and these cannot be remedied, referring to section 6. Troubleshooting, replace the related parts.	

- Notes
1. It is desirable to replace seal materials, such as O-rings, every disassembling. However, they may be reused, after being confirmed to be free of damage.
 2. When loosening the hexagon socket head cap screw(125), replace the seal washers(121) without fail.

6. RCV PEDAL

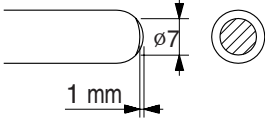
Maintenance check item	Criteria	Remark
Leakage	The valve is to be replaced when the leakage effect to the system. For example, the primary pressure drop.	Conditions : Primary pressure : 30 kgf/cm ² Oil viscosity : 23cSt
Spool	This is to be replaced when the sliding surface has worn more than 10μm, compared with the non-sliding surface.	The leakage at the left condition is estimated to be nearly equal to the above leakage.
Push rod	 <p>This is to be replaced when the top end has worn more than 1 mm.</p>	
Play at operating section	The pin, shaft, and joint of the operating section are to be replaced when their plays become more than 2mm due to wears or so on.	When a play is due to looseness of a tightened section, adjust it.
Operation stability	When abnormal noises, hunting, primary pressure drop, etc. are generated during operation, and these cannot be remedied, referring to section 6. Troubleshooting, replace the related parts.	

Notes 1. It is desirable to replace seal materials, such as O-rings, every disassembling. However, they may be reused, after being confirmed to be free of damage.

7. TURNING JOINT

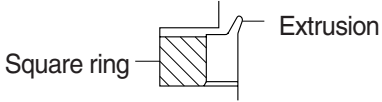
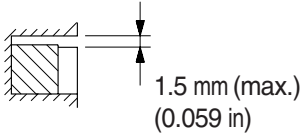
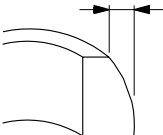
Part name		Maintenance standards	Remedy
Body, Stem	Sliding surface with sealing sections.	Plating worn or peeled due to seizure or contamination.	Replace
	Sliding surface between body and stem other than sealing section.	·Worn abnormality or damaged more than 0.1 mm (0.0039 in) in depth due to seizure contamination.	Replace
		·Damaged more than 0.1 mm (0.0039 in) in depth.	Smooth with oilstone.
	Sliding surface with thrust plate.	·Worn more than 0.5 mm (0.02 in) or abnormality.	Replace
		·Worn less than 0.5 mm (0.02 in).	Smooth
		·Damage due to seizure or contamination remediable within wear limit (0.5 mm) (0.02 in).	Smooth
Cover	Sliding surface with thrust plate.	·Worn more than 0.5 mm (0.02 in) or abnormality.	Replace
		·Worn less than 0.5 mm (0.02 in).	Smooth
		·Damage due to seizure or contamination remediable within wear limit (0.5 mm) (0.02 in).	Replace
Seal set	-	·Extruded excessively from seal groove square ring. 	Replace
	-	·Slipper ring 1.5 mm (0.059 in) narrower than seal groove, or narrower than back ring. 	Replace
	-	·Worn more than 0.5 mm (0.02 in)~1.5 mm (MAX.) (0.059 in) 	Replace

8. CYLINDER

Part name	Inspecting section	Inspection item	Remedy
Piston rod	· Neck of rod pin	· Presence of crack	· Replace
	· Weld on rod hub	· Presence of crack	· Replace
	· Stepped part to which piston is attached.	· Presence of crack	· Replace
	· Threads	· Presence of crack	· Recondition or replace
	· Plated surface	· Plating is not worn off to base metal. · Rust is not present on plating. · Scratches are not present.	· Replace or replate · Replace or replate · Recondition, replate or replace
	· Rod	· Wear of O.D.	· Recondition, replate or replace
	· Bushing at mounting part	· Wear of I.D.	· Replace
Cylinder tube	· Weld on bottom	· Presence of crack	· Replace
	· Weld on head	· Presence of crack	· Replace
	· Weld on hub	· Presence of crack	· Replace
	· Tube interior	· Presence of faults	· Replace if oil leak is seen
	· Bushing at mounting part	· Wear on inner surface	· Replace
Gland	· Bushing	· Flaw on inner surface	· Replace if flaw is deeper than coating