

GROUP 4 HYDRAULIC SYSTEM

HYDRAULIC COMPONENTS MOUNTING 1

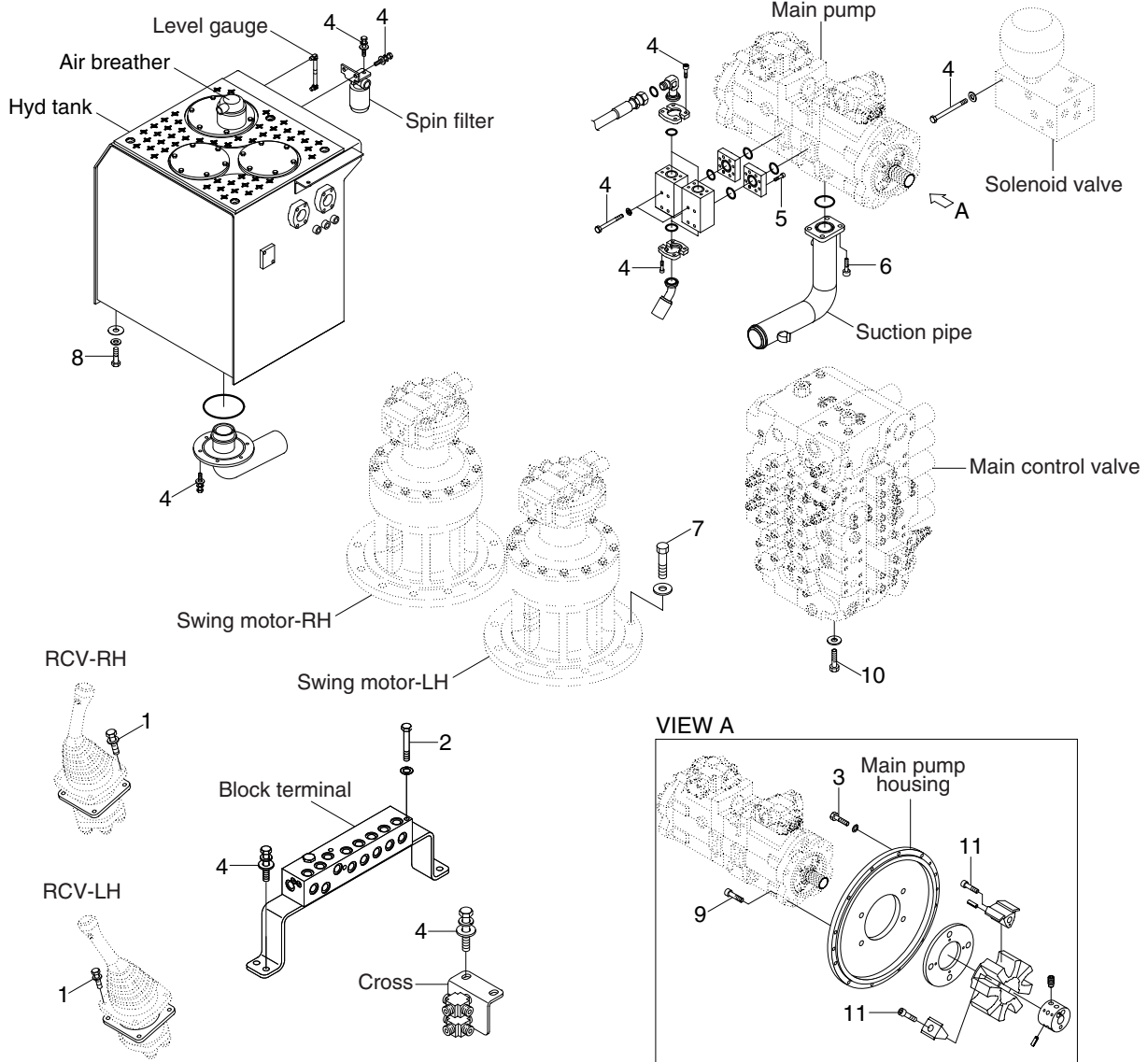

4809MH9CM05

· Tightening torque

Item	Size	kgf · m	lbf · ft
1	M 6×1.0	1.05±0.2	7.6±1.45
2	M 8×1.25	2.5±0.5	18.1±3.6
3	M10×1.5	4.8±0.3	34.7±2.2
4	M10×1.5	6.9±1.4	49.9±10.1
5	M12×1.75	12.3±1.3	88.2±9.4
6	M16×2.0	29.7±4.4	215±31.8

Item	Size	kgf · m	lbf · ft
7	M20×2.5	58.4±6.4	422±46.2
8	M20×2.5	46±5.1	333±36.9
9	M20×2.5	44±6.6	318±47.7
10	M20×2.5	57.9±8.7	419±62.9
11	M20×2.5	46.5±2.5	336±18
-	-	-	-

HYDRAULIC COMPONENTS MOUNTING 2

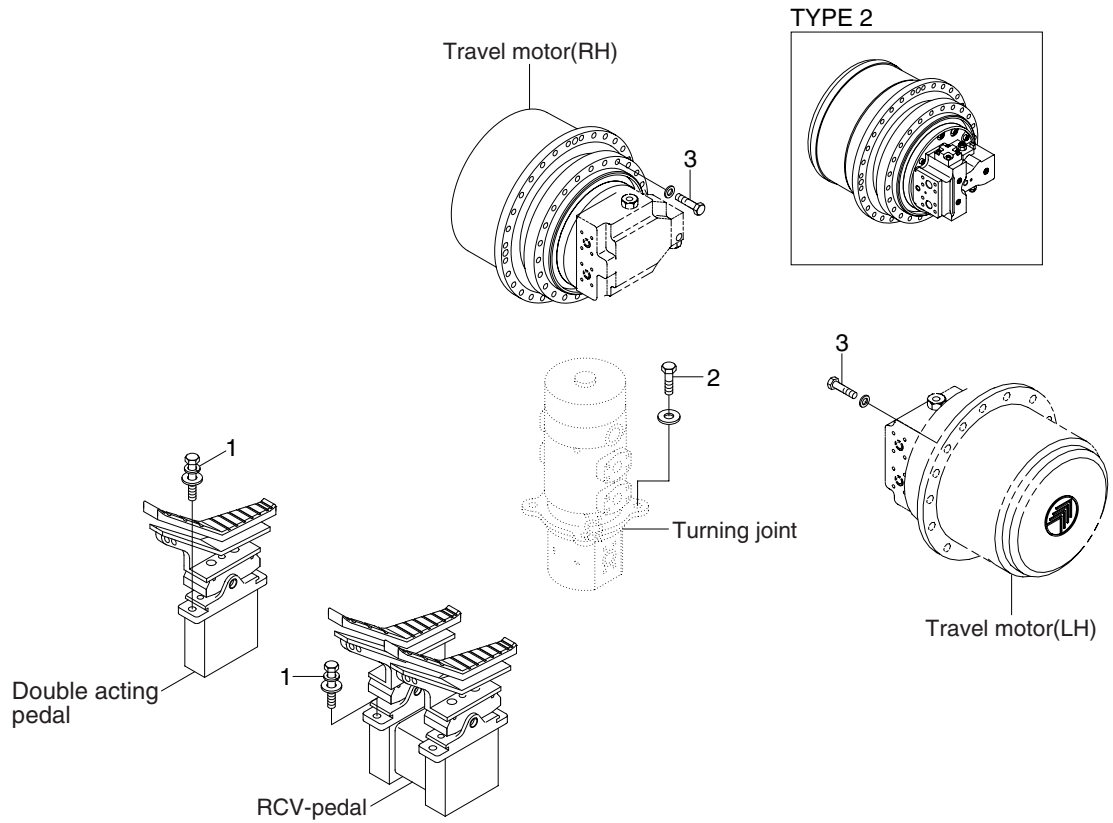

4809MH9CM06

· Tightening torque

Item	Size	kgf · m	lbf · ft
1	M10×1.5	6.9±1.4	49.9±10.1
2	M16×2.0	29.7±4.5	215±32.5

Item	Size	kgf · m	lbf · ft
3	M20×2.5	57.9±8.7	419±62.9
-	-	-	-

HYDRAULIC COMPONENTS MOUNTING 3

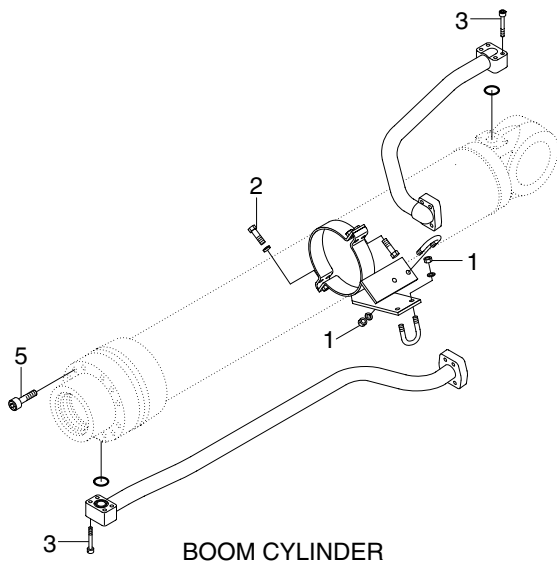

SOLENOID VALVE

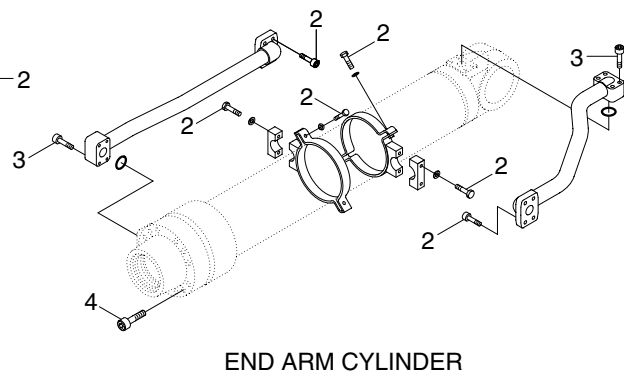
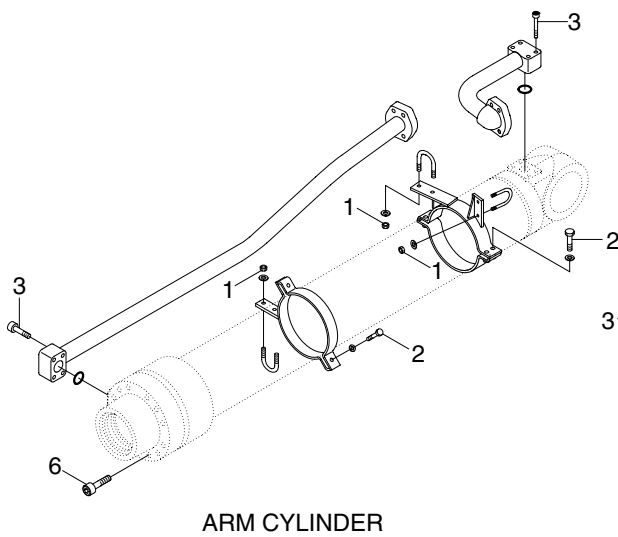
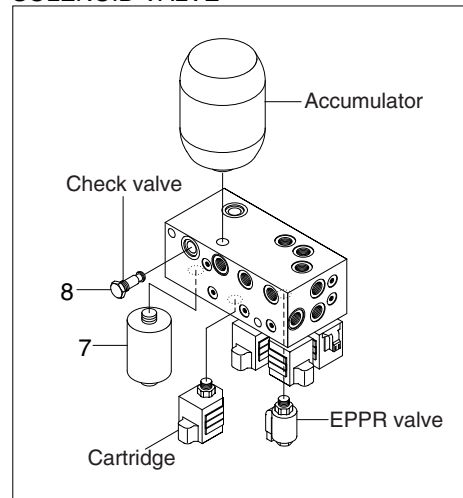

4809MH9CM07

· Tightening torque

Item	Size	kgf · m	lbf · ft
1	M10×1.5	3.2±0.3	23.1±2.2
2	M12×1.75	5.5±0.6	39.8±4.3
3	M12×1.75	9.4±1.0	68.0±7.2
4	M20×2.5	46±5.0	333±36.2

Item	Size	kgf · m	lbf · ft
5	M22×2.5	63±6.0	456±43.4
6	M24×3.0	79±8.0	571±57.9
7	Line filter	2.5	18.0
8	Check valve	4.0	28.9