

GROUP 6 TRAVEL DEVICE (TYPE 1, 2)

1. REMOVAL AND INSTALL

1) REMOVAL

- (1) Swing the work equipment 90 ° and lower it completely to the ground.
- (2) Operate the control levers and pedals several times to release the remaining pressure in the hydraulic piping.
- (3) Loosen the breather slowly to release the pressure inside the hydraulic tank.

▲ Escaping fluid under pressure can penetrate the skin causing serious injury.

- ※ When pipes and hoses are disconnected, the oil inside the piping will flow out, so catch it in oil pan.
- (4) Remove the track shoe assembly.
For details, see removal of track shoe assembly.
 - (5) Remove the cover.
 - (6) Remove the hoses.
 - ※ Fit blind plugs to the disconnected hoses.
 - (7) Remove the bolts and the sprocket.
 - (8) Sling travel device assembly (1).
 - (9) Remove the mounting bolts (2), then remove the travel device assembly.
 - Weight : 632 kg (1393 lb)
 - Tightening torque : 57.9 ± 8.7 kgf · m
(419 ± 62.9 lbf · ft)

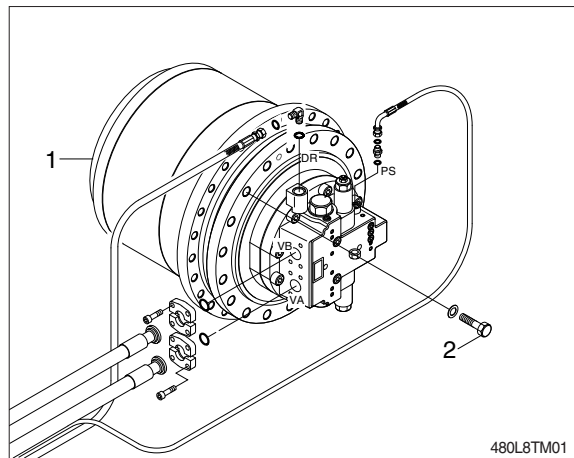

2) INSTALL

- (1) Carry out installation in the reverse order to removal.
- (2) Bleed the air from the travel motor.
 - ① Remove the air vent plug.
 - ② Pour in hydraulic oil until it overflows from the port.
 - ③ Tighten plug lightly.
 - ④ Start the engine, run at low idling, and check oil come out from plug.
 - ⑤ Tighten plug fully.
- (3) Confirm the hydraulic oil level and check the hydraulic oil leak or not.

2. TRAVEL MOTOR

1) STRUCTURE (TYPE 1)

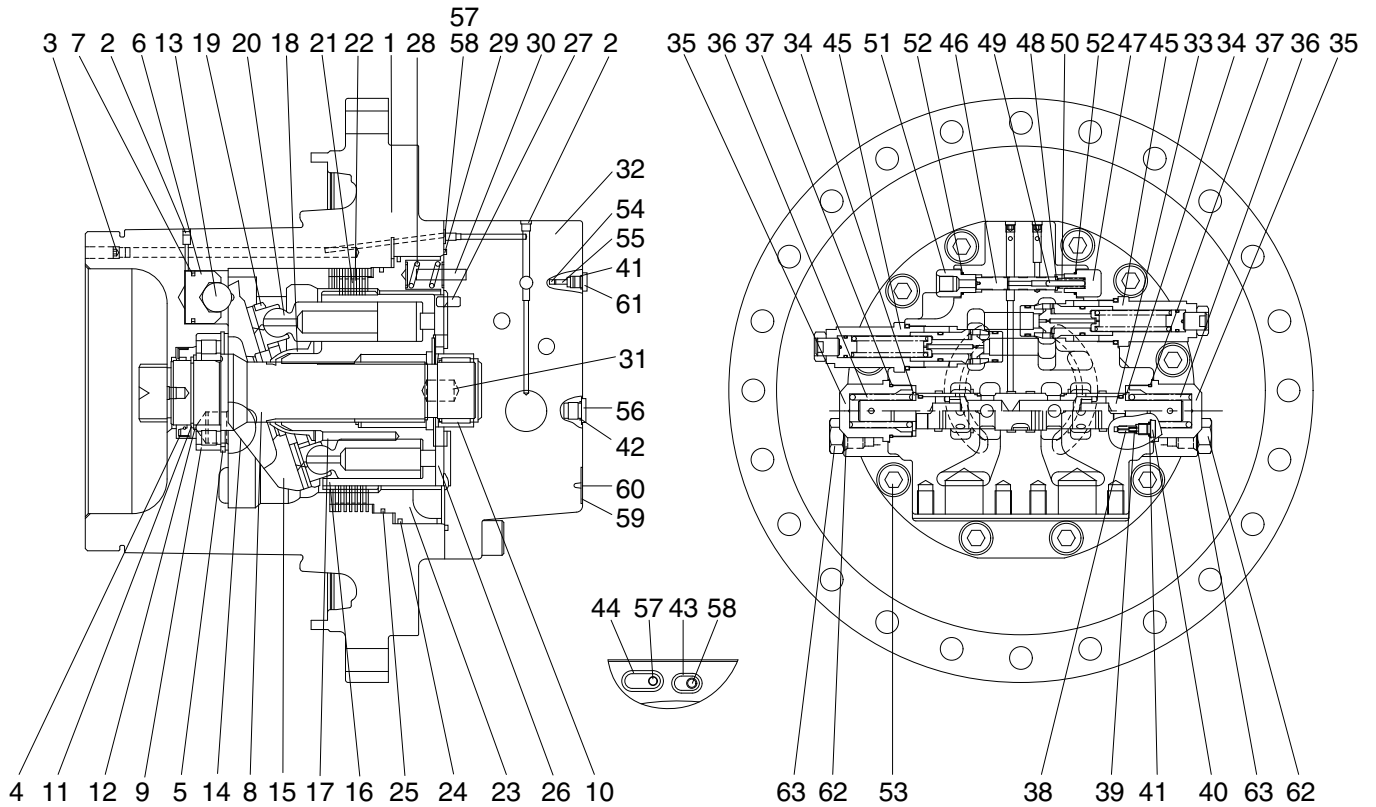

480A2TM02

1	Casing	22	Separate plate	43	O-ring
2	Plug	23	Parking piston	44	O-ring
3	Plug	24	D-ring	45	Relief valve assy
4	Oil seal	25	D-ring	46	Spool
5	Retainer ring	26	Valve plate	47	Plug
6	Piston	27	Parallel pin	48	Spring seat
7	Piston seal	28	Spring	49	Parallel pin
8	Shaft	29	O-ring	50	Spring
9	Roller bearing	30	Spring pin	51	Connector
10	Needle bearing	31	Parallel pin	52	O-ring
11	Retainer ring	32	Rear cover	53	Hex socket head bolt
12	Thrust plate	33	Main spool kit	54	Check valve
13	Steel ball	34	Spring seat	55	Spring
14	Pivot	35	Plug	56	Plug
15	Swash plate	36	Spring	57	Restrictor
16	Rotary block	37	O-ring	58	Restrictor
17	Spring	38	Restrictor	59	Name plate
18	Ball guide	39	Spring	60	Rivet
19	Retainer plate	40	Plug	61	Plug
20	Piston and shoe	41	O-ring	62	Plug
21	Friction plate	42	O-ring	63	O-ring

STRUCTURE (TYPE 2)

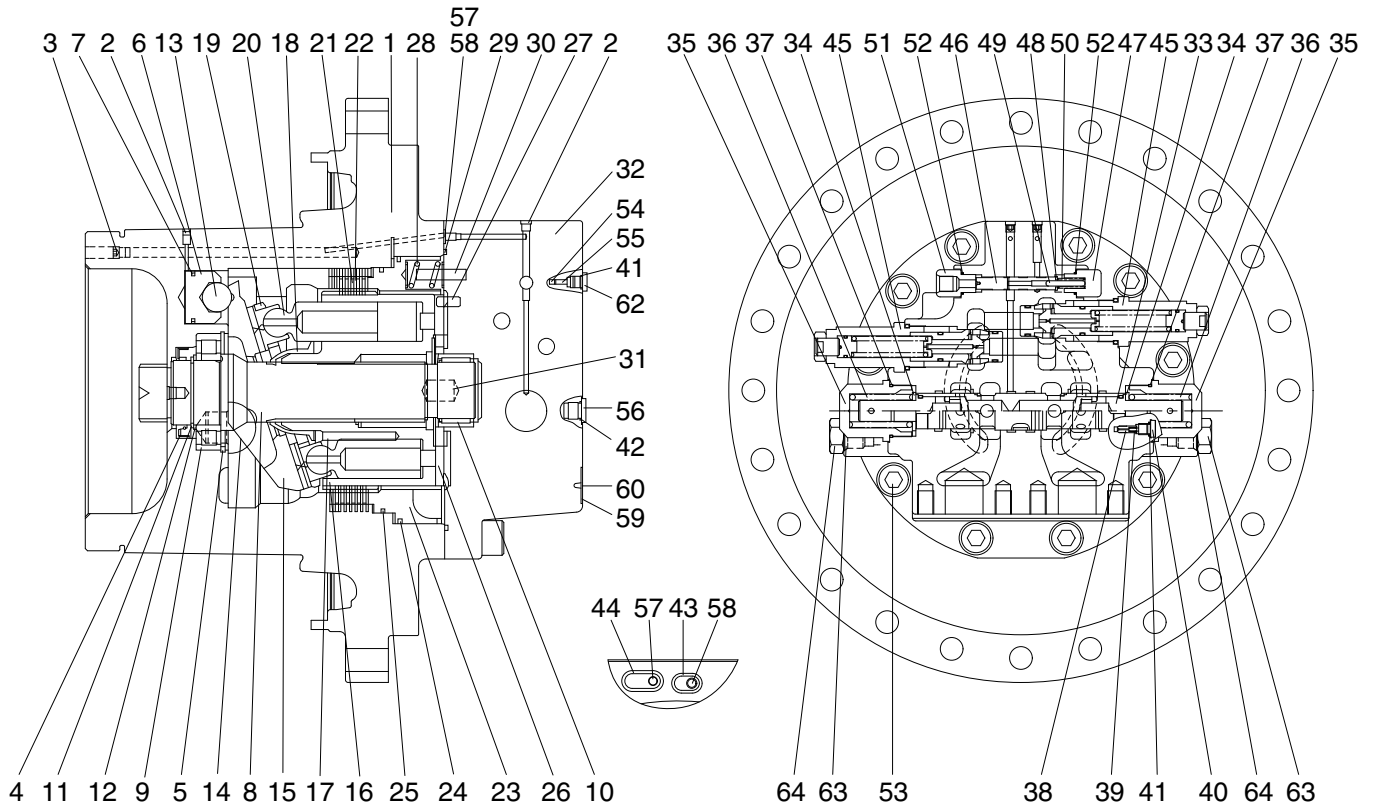

480F2TM02

1	Casing	22	Separate plate	43	O-ring
2	Plug	23	Parking piston	44	O-ring
3	Plug	24	D-ring	45	Relief valve assy
4	Oil seal	25	D-ring	46	Spool
5	Retainer ring	26	Valve plate	47	Plug
6	Piston	27	Parallel pin	48	Spring seat
7	Piston seal	28	Spring	49	Parallel pin
8	Shaft	29	O-ring	50	Spring
9	Roller bearing	30	Spring pin	51	Connector
10	Needle bearing	31	Parallel pin	52	O-ring
11	Retainer ring	32	Rear cover	53	Hex socket head bolt
12	Thrust plate	33	Main spool kit	54	Check valve
13	Steel ball	34	Spring seat	55	Spring
14	Pivot	35	Plug	56	Plug
15	Swash plate	36	Spring	57	Restrictor
16	Rotary block	37	O-ring	58	Restrictor
17	Spring	38	Restrictor	59	Name plate
18	Ball guide	39	Spring	60	Rivet
19	Retainer plate	40	Plug	62	Plug
20	Piston and shoe	41	O-ring	63	Plug
21	Friction plate	42	O-ring	64	O-ring

3. DISASSEMBLING OF MOTOR

1) GENERAL PRECAUTIONS

- (1) Pay attention to not damaging contact surfaces for O-rings, oil seals, etc. and contact/sliding surfaces for gears, pins, bearings, etc.
- (2) This motor can be disassembled even in a state on the reduction gear. However, in that case, pay full attention to preventing mud, dust, etc. from entering in it.
- (3) The numerical in parentheses following each part name indicates its part number shown in the attached **assembly drawings**.
- (4) The piping side of the motor is referred to as the rear side, and the output side as the front side.

2) DISASSEMBLY OF REDUCTION GEAR

- (1) Disassemble relief valve assy (45) from rear cover (32) using spanner and torque wrench.

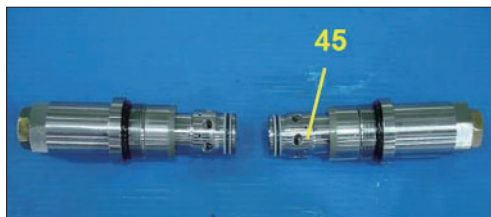

480L2TM11

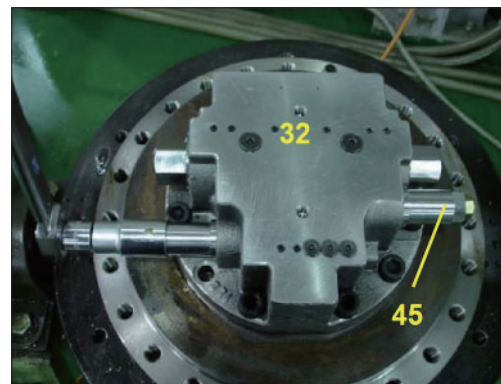

480L2TM12

- (2) Disassemble plug (35) from rear cover (32) and then disassemble spring (36), spring seat (34), main spool kit (33) in regular sequence.

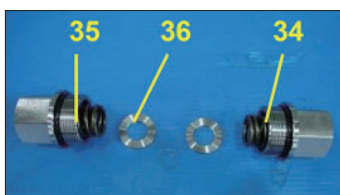

480L2TM13

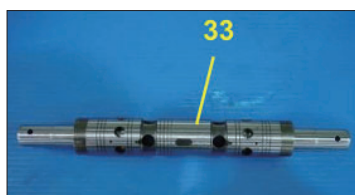

480L2TM14

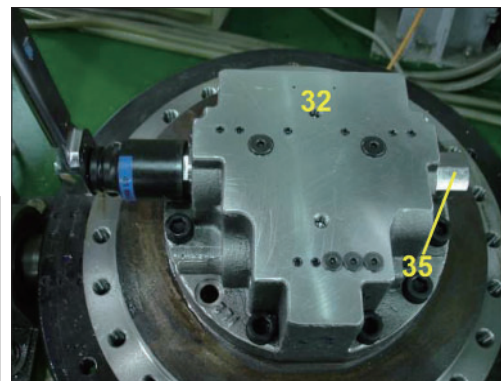

480L2TM15

- (3) Disassemble socket bolt (53)-10EA using torque wrench.

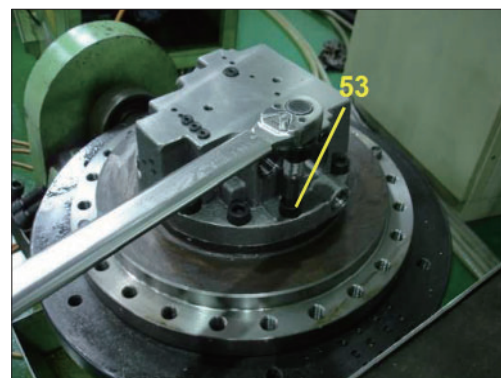

480L2TM16

(4) Take out rear cover (32) from casing (1).

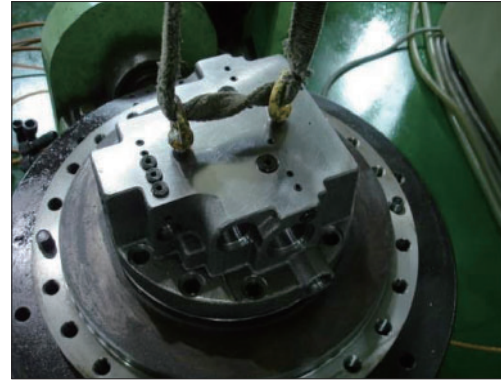

480L2TM17

(5) Disassemble parking piston (23) using jig.



480L2TM18

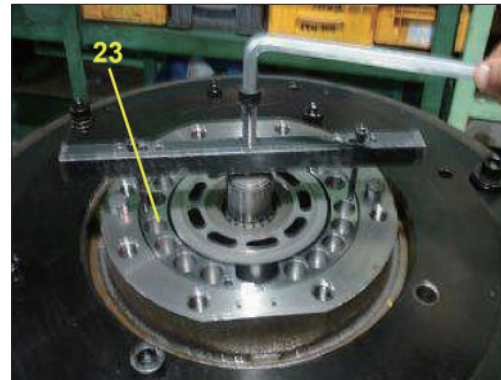

480L2TM19

(6) Disassemble separate plate (22)-7EA, friction plate (21)-6EA

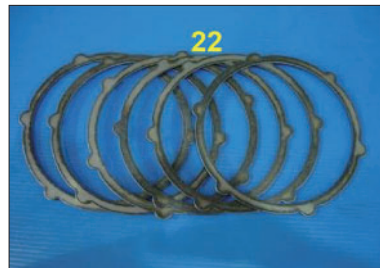

480L2TM20

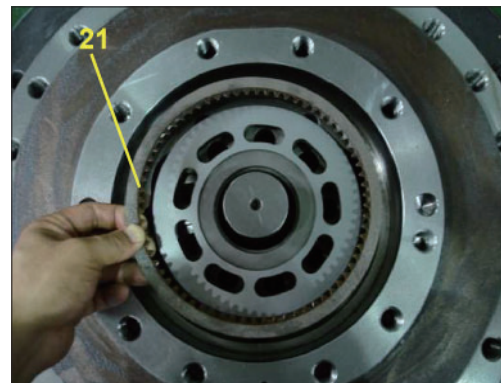

480L2TM21

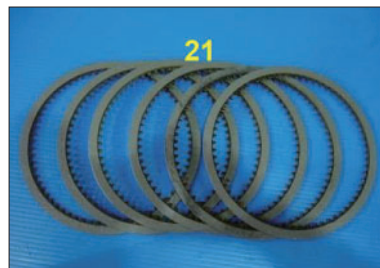

480L2TM22

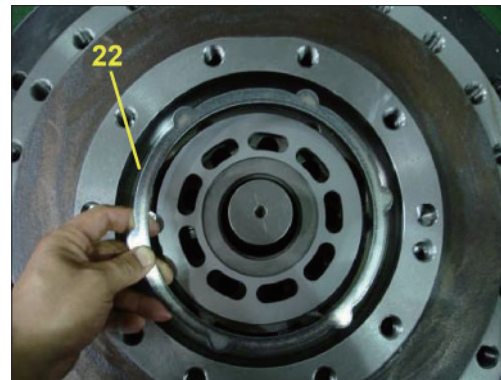

480L2TM23

- (7) Remove rotary block kit.
It is easier to work by placing the casing (1) horizontal.

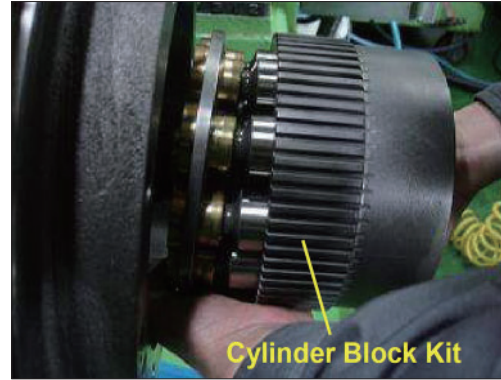

480L2TM24

- (8) Disassemble rotary block (16), retainer plate (19), piston and shoe (20), ball guide (18), spring (17) from rotary block kit.



480L2TM25



480L2TM26

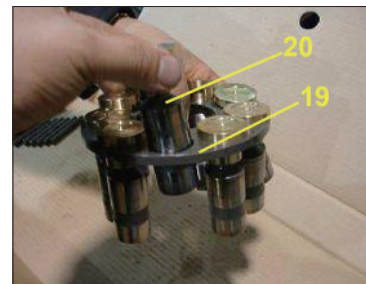

480L2TM27

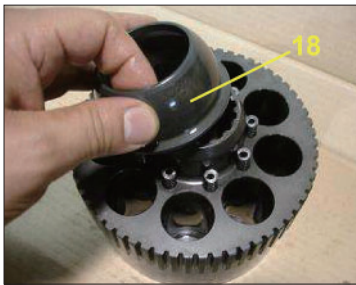

480L2TM28

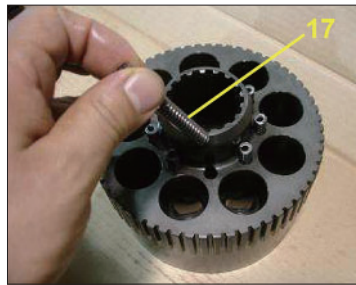

480L2TM29

- (9) Disassemble swash plate (15) from shaft casing (1).



480L2TM30



480L2TM31

(10) Disassemble steel ball (13), swash piston (6)
Hole in the casing (1) of two speed line is decomposed by injecting oil.

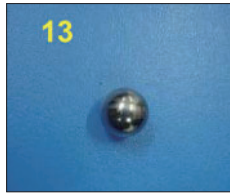

480L2TM32

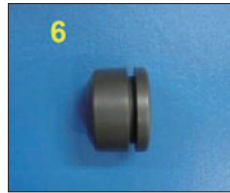

480L2TM33



480L2TM34

(11) Disassemble pivot (14)-2EA from casing (1).

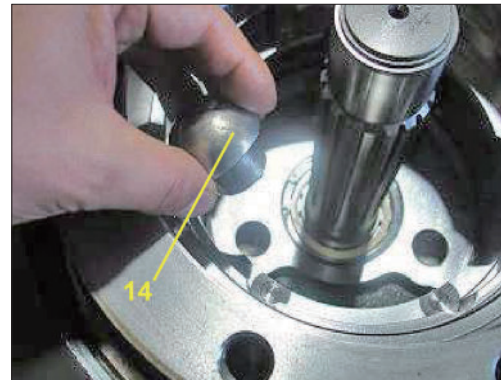

480L2TM35

(12) Disassemble retainer ring (5) using pliers.

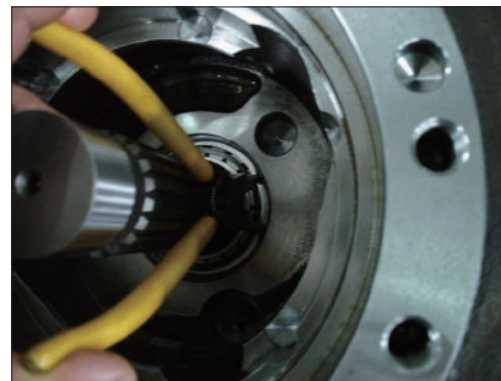

480L2TM36

(13) In the casing (1), the arrow part of the shaft (8)
using a rubber mallet taps and then disassemble the shaft (8) and roller bearing (9)
to the other side.

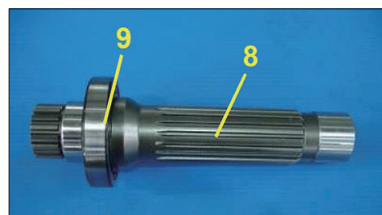

480L2TM37

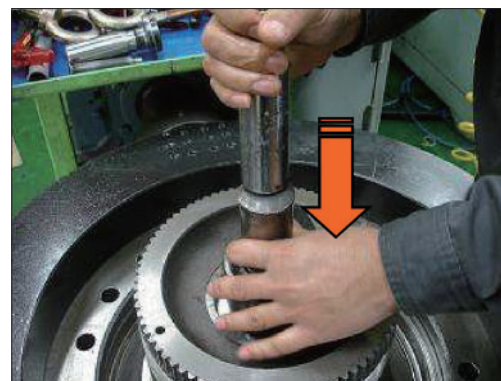

480L2TM38

(14) Disassemble valve plate (36) from rear cover (32).

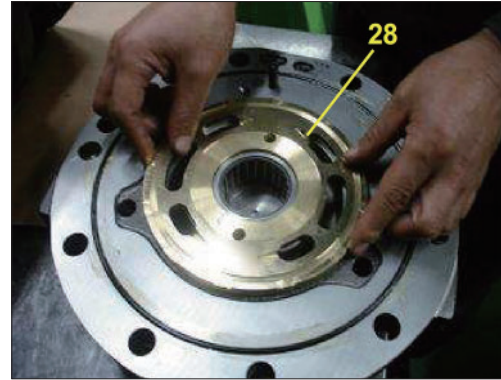

480L2TM39

(15) Disassemble plug (47), connector (51) from rear cover (32) and then disassemble spring (50), spring seat (48), parallel pin (49), spool (46) in regular sequence.

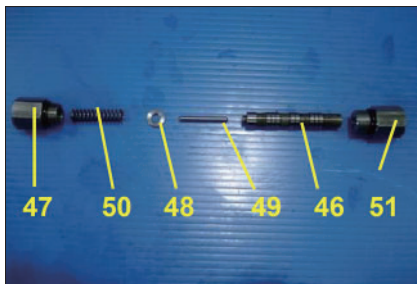

480L2TM40

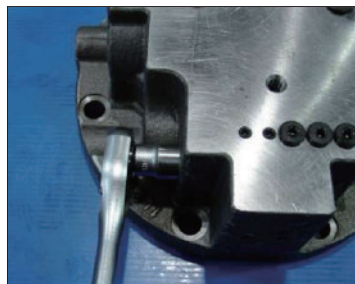

480L2TM41

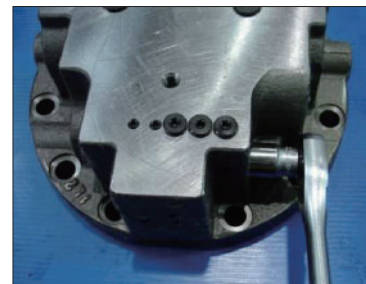

480L2TM42

(16) Disassemble plug (40) from rear cover (32) and then disassemble spring (39), restictor (38) from rear cover (34) in regular sequence.

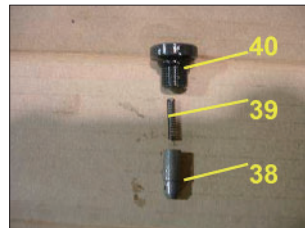

480L2TM43

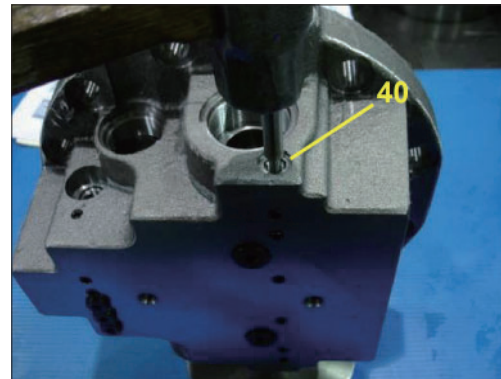

480L2TM44

(17) Disassemble plug (40) from rear cover (32) and then disassemble spring (55), check valve (54) from rear cover (32) in regular sequence.

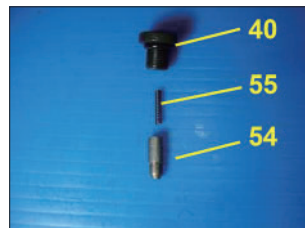

480L2TM45

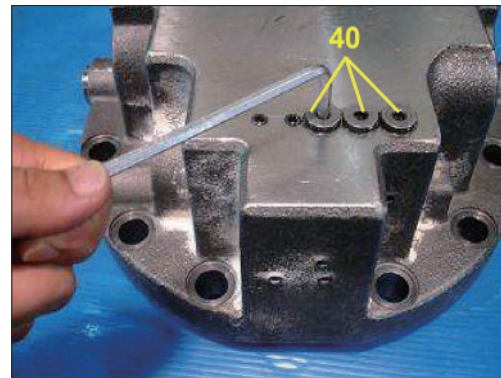

480L2TM46

(18) Disassemble plug (56) from rear cover (32).

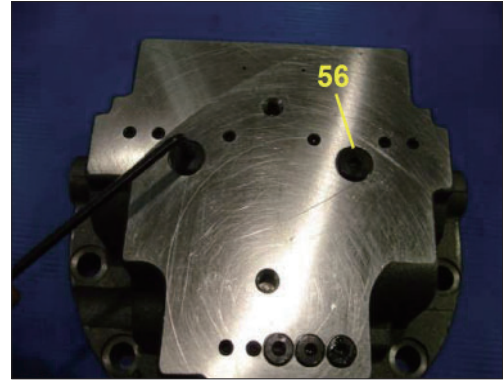

480L2TM47

2) ASSEMBLY OF MOTOR

- (1) Insert check valve (54), spring (55) into rear cover (32) and then assemble plug (40) using torque wrench.

· Tightening torque : $3.0 \pm 0.3 \text{ kgf} \cdot \text{m}$
($21.7 \pm 2.2 \text{ lbf} \cdot \text{ft}$)

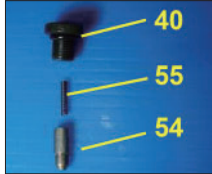

480L2TM48

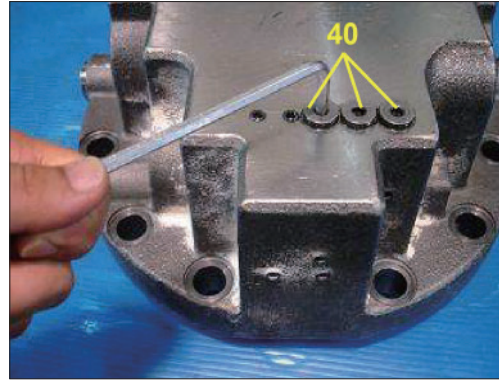

480L2TM49

- (2) Insert restrictor (38), spring (39) into rear cover (32) and then assemble plug (40) using torque-wrench.

· Tightening torque : $3.0 \pm 0.3 \text{ kgf} \cdot \text{m}$
($21.7 \pm 2.2 \text{ lbf} \cdot \text{ft}$)

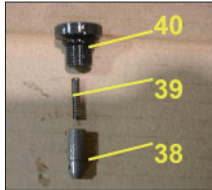

480L2TM50

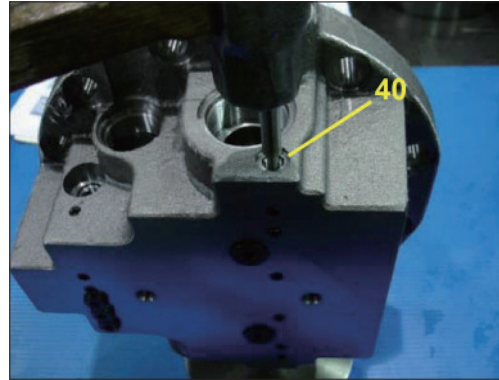

480L2TM51

- (3) Apply loctite #242 on the 14-NPTF 1/16 plug (2) and then assemble 14-NPTF 1/16 plug (2) into rear cover (32).



480L2TM52

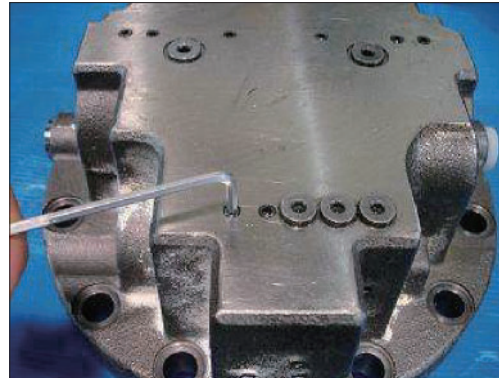

480L2TM53

- (4) Assemble 2-PF1/4 plug (56, 61) using torque-wrench.

· Tightening torque : $4.5 \pm 0.5 \text{ kgf} \cdot \text{m}$
($32.5 \pm 3.6 \text{ lbf} \cdot \text{ft}$)

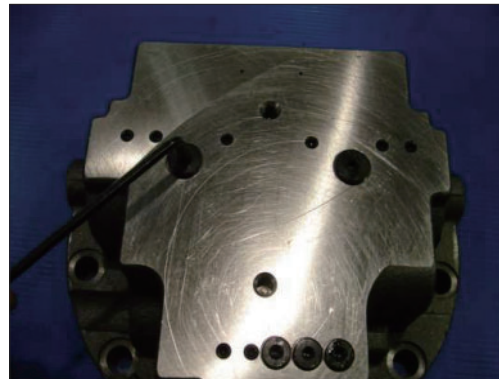

480L2TM54

- (5) Insert spool (46), parallel pin (49), spring seat (48), spring (50) in regular sequence and then assemble plug (47), connector (51) using torque wrench.
 · Tightening torque : $5.5 \pm 0.5 \text{ kgf} \cdot \text{m}$ ($40 \pm 3.6 \text{ lbf} \cdot \text{ft}$)

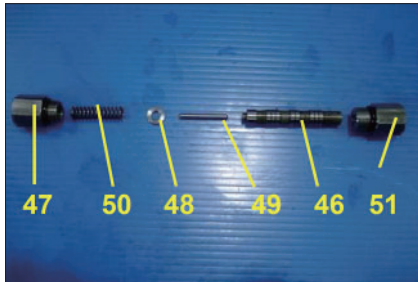

480L2TM55

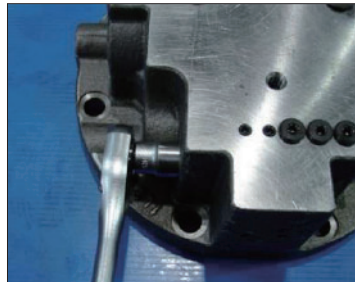

480L2TM56

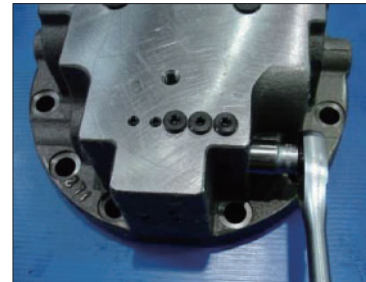

480L2TM57

- (6) Press needle bearing (10) into rear cover (32) using jig.



480L2TM58

- (7) Assemble spring pin (30), parallel pin (27) using small hammer.



480L2TM59

- (8) Apply loctite #242 on the restrictor (57, 58) and then assemble restrictor (57, 58), O-ring (43, 44) into rear cover (32).



480L2TM60

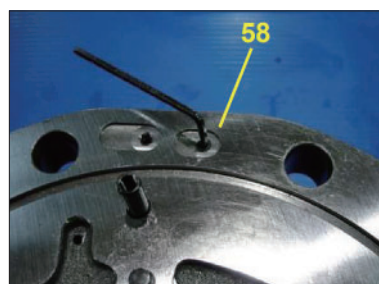

480L2TM61

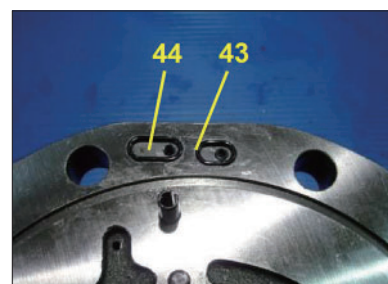

480L2TM62

- (9) Assemble valve plate (26) into rear cover (32).
Apply grease to the valve plate contact and then assemble valve plate into rear cover (32).

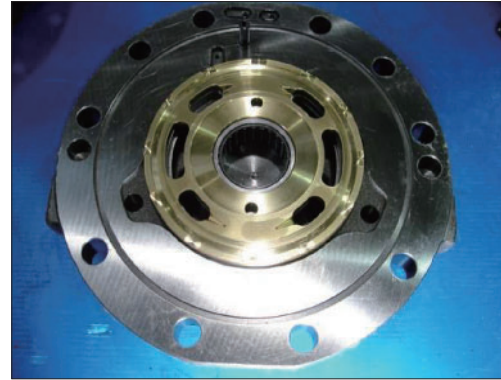

480L2TM63

- (10) Apply grease to the O-ring (29), and then assemble O-ring into rear cover (32).

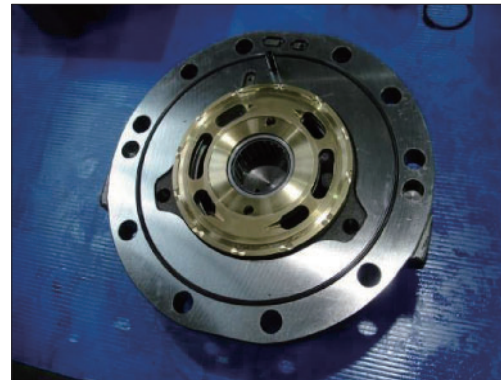

480L2TM64

- (11) Assemble the heated roller bearing (9) onto the shaft (8) and then assemble retainer ring (5) into shaft (8).

- ① The temperature of the roller bearing : 100°C
* Using tool : heater.
- ② Be careful not to damage the sliding surface for the oil seal on the shaft.

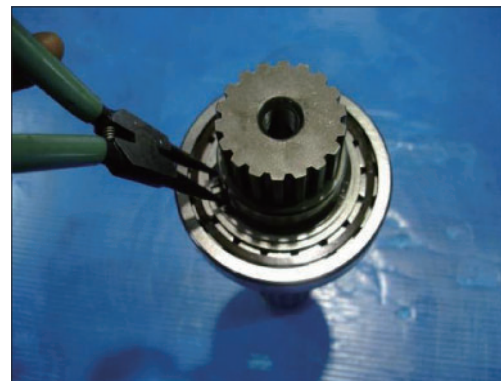

480L2TM65



480L2TM66



480L2TM67



480L2TM68

(12) Install casing (1) into assembling jig.

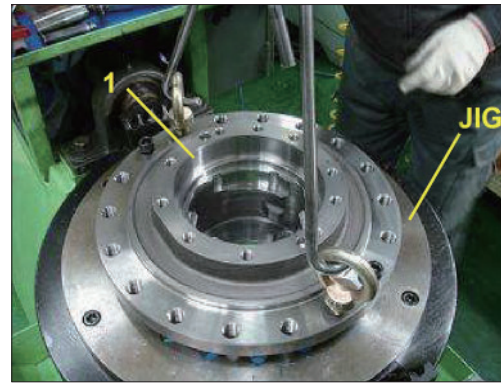

480L2TM69

(13) Assemble plug (2), (3) into casing (1).

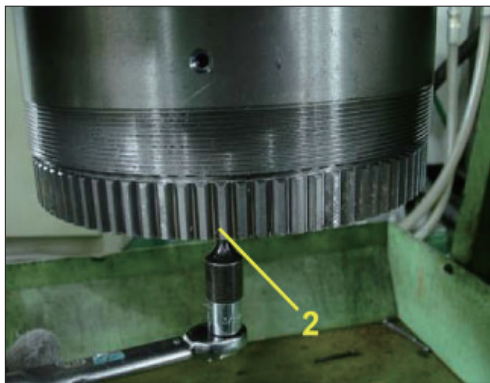

480L2TM70



480L2TM71

(14) Assemble oil seal (4) into casing (1) with assembling jig.

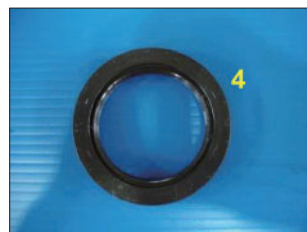

480L2TM72



480L2TM73

(15) Insert assembled shaft assy in the direction of the arrow into casing (1) using a rubber mallet.

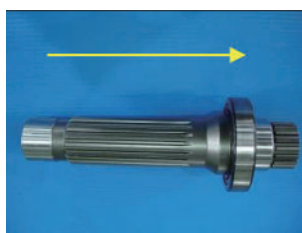

480L2TM74



480L2TM75

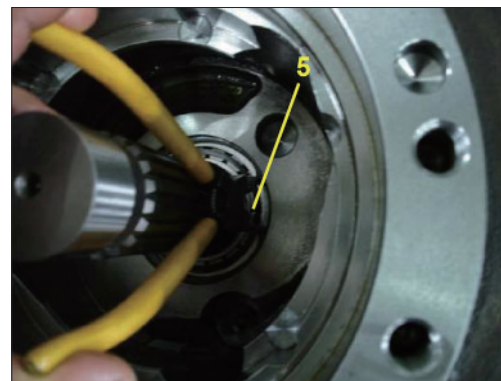

480L2TM76

(16) Apply the grease to pivot (14)-2EA and then assemble pivot (14) into casing (1).

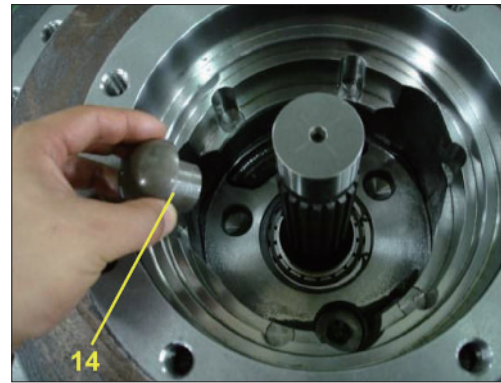

480L2TM77

(17) Warm piston seal (7) and assemble it on swash piston (6) and then bind the piston seal (7) with a bend for a minute. Remove the bend and assemble it into casing (1).

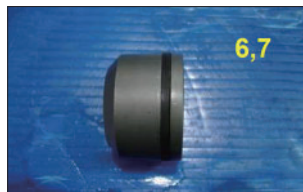

480L2TM78

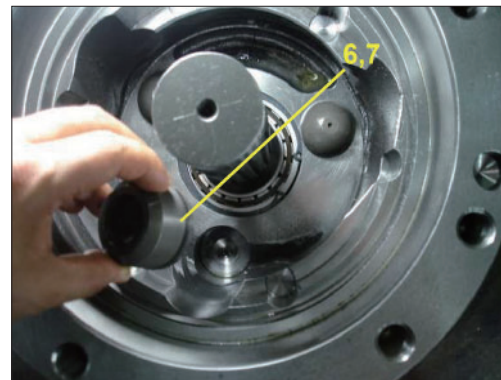

480L2TM79

(18) Apply the grease to steel ball (13) and then assemble steel ball (13) into casing (1).



480L2TM80

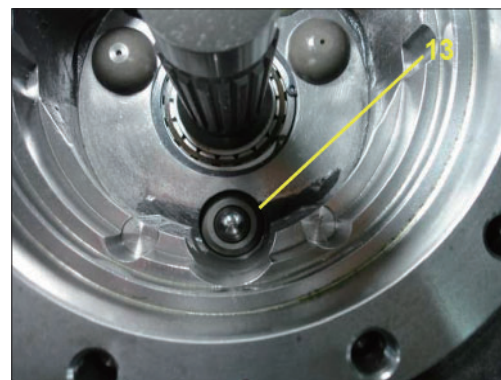

480L2TM81

(19) Apply the grease to swash plate (15) and then assemble swash plate (15) into casing (1).



480L2TM82

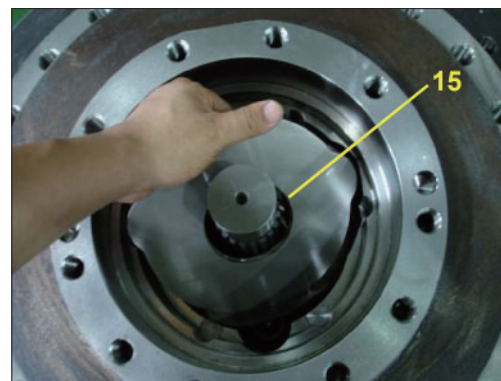

480L2TM83

(20) Assemble spring (17), ball guide (18), retainer plate (19), piston and shoe (20) into rotary block (16) in regular sequence.

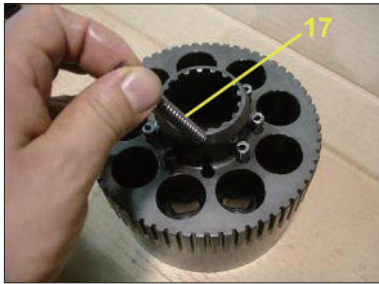

480L2TM84



480L2TM85

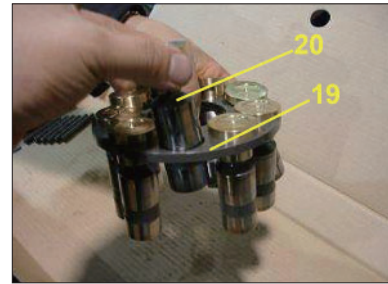

480L2TM86



480L2TM87



480L2TM88

(21) Assemble rotary block kit into casing (1).

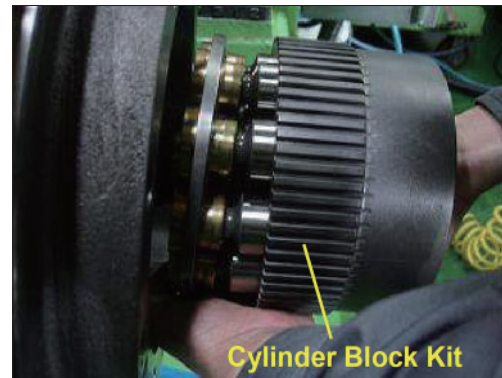

480L2TM89

(22) Assemble separate plate (22), friction plate (21) into rotary block in regular sequence.

Friction plate : 6 EA

Separate plate : 7 EA

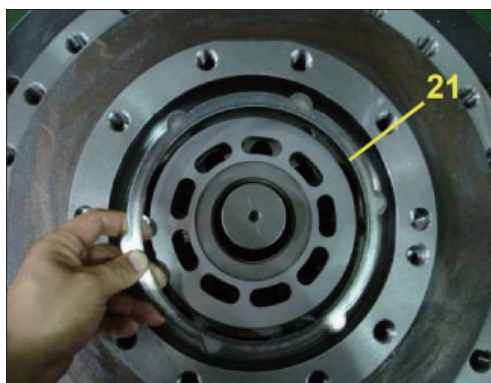

480L2TM90

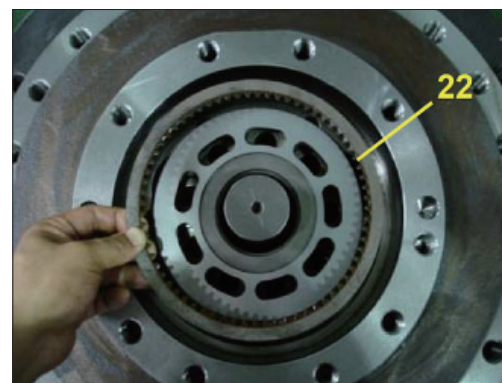

480L2TM91

(23) Assemble parallel pin (31) into casing (1).

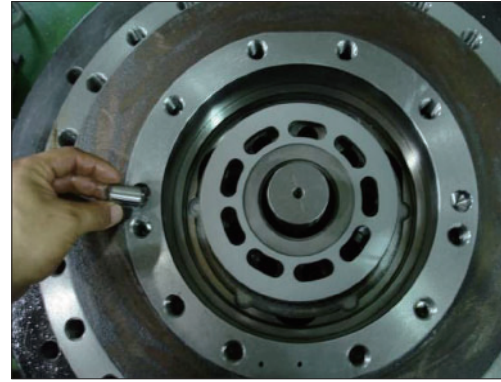

480L2TM92

(24) Apply the grease to D-ring (24,25) and then assemble D-ring (24, 25) into parking piston (23)

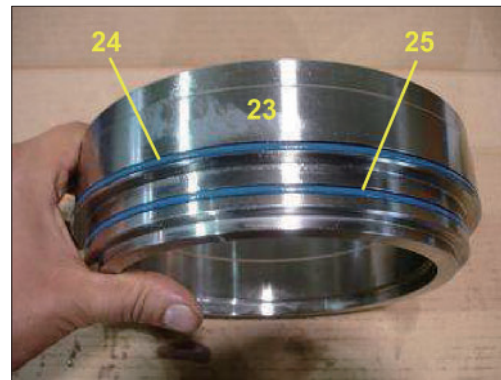

480L2TM93

(25) Assemble parking piston (23) into casing using jig.



480L2TM94

(26) Assemble parking spring (28)-14EA.

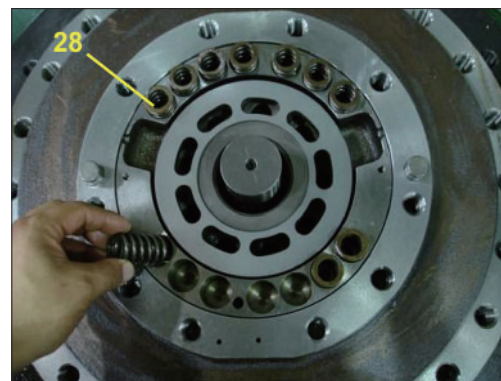

480L2TM95

(27) Put on the rear cover (32) on the casing (1).



480L2TM96

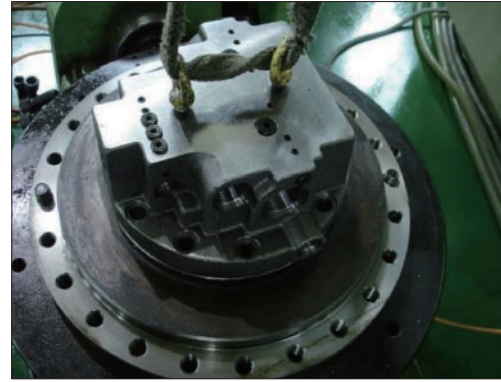

480L2TM97

(28) Assemble rear cover (32) into casing (1) and then tighten the socket bolt (53) using torque wrench.

- Tightening torque : $33 \pm 3.3 \text{ kgf} \cdot \text{m}$
($239 \pm 23.9 \text{ lbf} \cdot \text{ft}$)

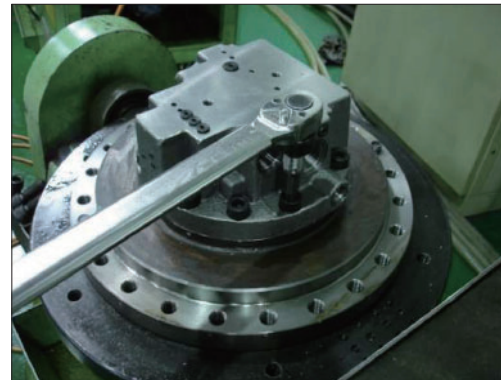

480L2TM98

(29) Assemble main spool kit (33) into rear cover (32) after checking the direction to be correct.



480L2TM99

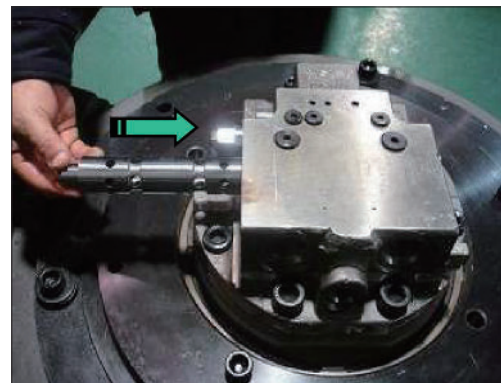

480L2TM100

(30) Assemble spring (36), plug (35) into rear cover (32) in regular sequence and then plug (35) into rear cover (32) using torque wrench.

- Tightening torque : $45 \pm 4.5 \text{ kgf} \cdot \text{m}$ ($325 \pm 32.5 \text{ lbf} \cdot \text{ft}$)



480L2TM101

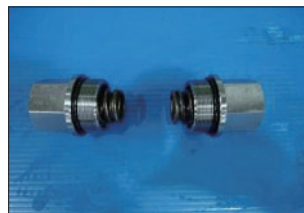

480L2TM102

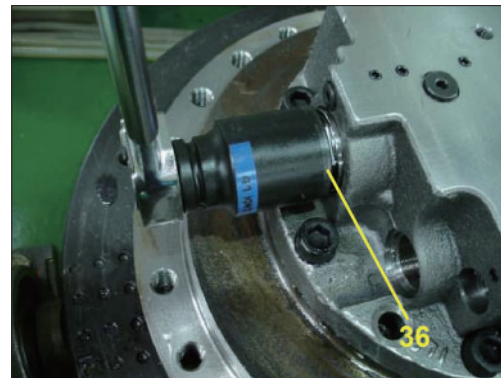

480L2TM103

(31) Assemble relief valve assy (45) using torque wrench.

- Tightening torque : $26 \pm 2.6 \text{ kgf} \cdot \text{m}$
($188 \pm 18.8 \text{ lbf} \cdot \text{ft}$)

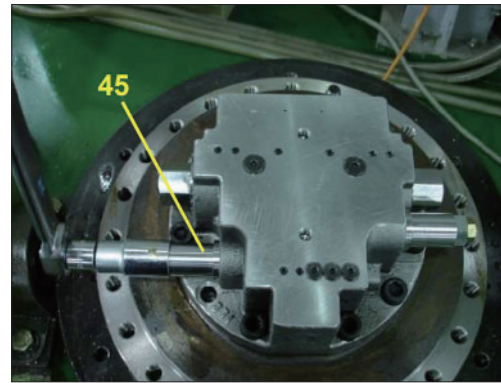

480L2TM104

4. TRAVEL REDUCTION GEAR

1) STRUCTURE

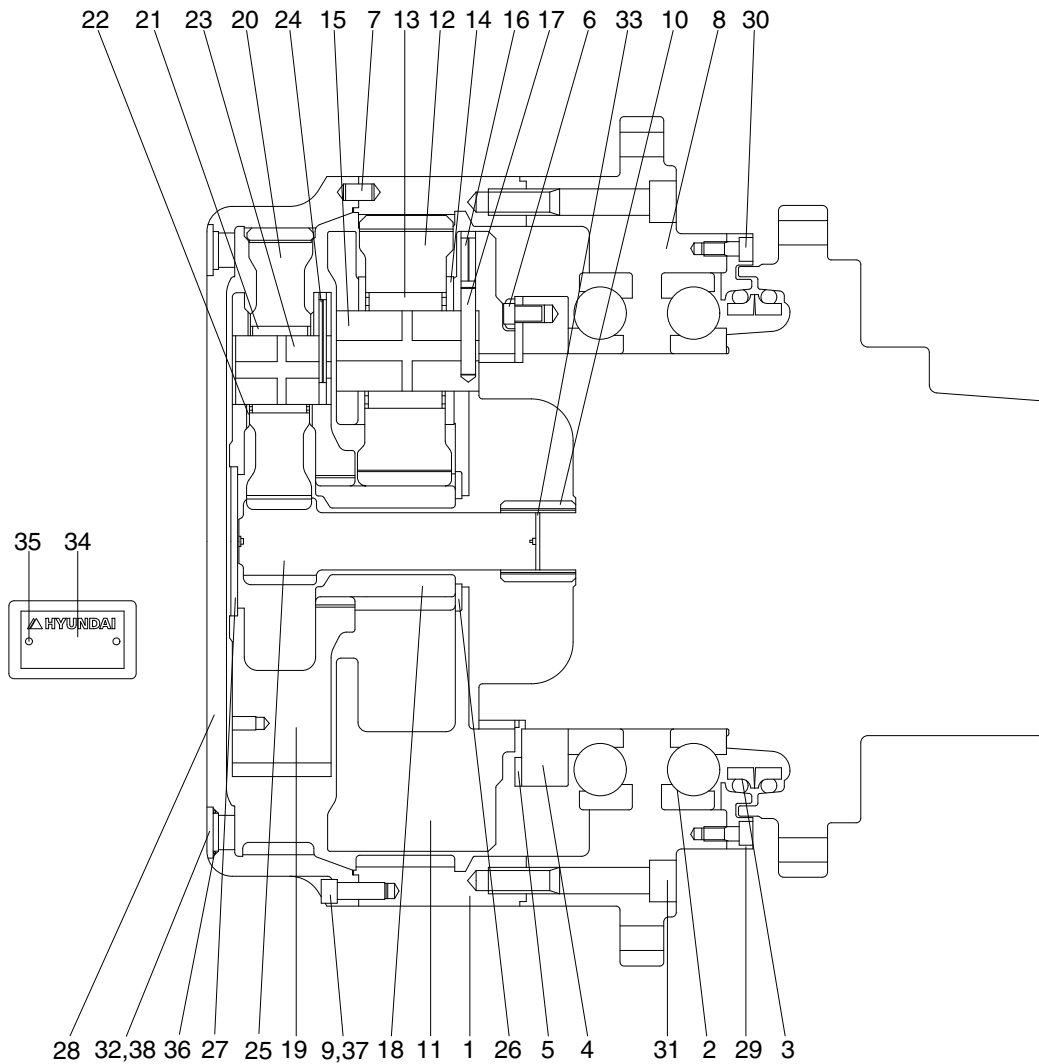

480A2TM03

1	Ring gear	14	Thrust washer	27	Thrust plate
2	Ball bearing	15	Carrier pin No. 2	28	Cover
3	Floating seal assy	16	Spring pin	29	Cover seal
4	Ring nut	17	Solid pin No. 2	30	Hex socket head bolt
5	Lock plate	18	Sun gear No. 2	31	Hex socket head bolt
6	Hexagon head bolt	19	Carrier No. 1	32	Plug
7	Parallel pin	20	Planetary gear No. 1	33	Retainer ring
8	Housing	21	Needle bearing	34	Name plate
9	Hexagon socket head bolt	22	Thrust washer	35	Rivet
10	Coupling	23	Carrier pin No. 1	36	O-ring
11	Carrier No. 2	24	Spring pin	37	Rubber cap
12	Planetary gear No. 2	25	Sun gear No. 1	38	Rubber cap
13	Needle bearing	26	Thrust plate		

5. DISASSEMBLY OF REDUCTION GEAR

1) READY FOR DISASSEMBLING

- (1) Reduction gear removed from machine usually covered with dirt, so clean it with cleaning liquid and dry it.
- (2) Put reduction gear on stable place with drain port down side and remove oil plug (PF3/4) to pull-out gear oil through drain port.
 - ※ When the oil is hot, there are high chance to blow out hot oil because of the pressure difference between container and out side.
- (3) Set reduction gear on work table.
- (4) Mark surface of cover, ring gear and housing for proper reassembly.

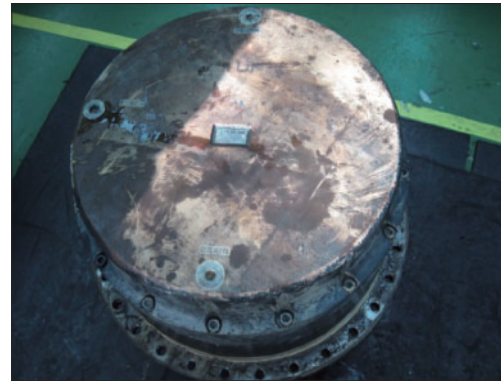

480L2TM201

2) PUT REDUCTION GEAR ON WORK TABLE TO DISASSEMBLE

- (1) Set eye bolt (M20) into M20 tap hole on housing flange. Make reduction gear cover upper direction using hoist machine.
 - ▲ **Be aware of safety. There are some chances of accidents when put down the reduction gear. Do not place the part pall on your foot.**



480L2TM202

3) COVER REMOVE

- (1) Remove 16 of bolt-hex. socket head (M12X35L) connecting cover and ring gear using torque wrench.
- (2) Using sharp tools to separate cover and ring gear. Put sharp tools into the gap between ring gear and cover and tap the tool tenderly.



480L2TM203

4) REMOVE THRUST PLATE AND NO.1 CARRIER SUB

- (1) Remove thrust plate first, set eye bolt (M10) in No.1 carrier tap hole. After these, pull-up No.1 carrier assy slowly.

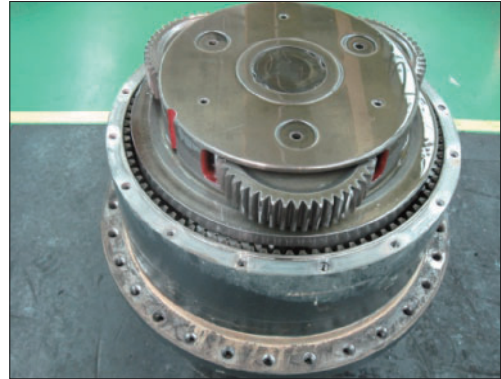

480L2TM204

- (2) Remove No.1 sun gear from reduction gear slowly.
※ When disassemble No.1 sun gear, be sure to keep vertical against ground with No.1 sun gear.

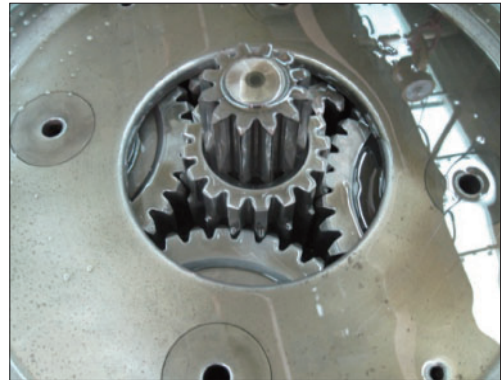

480L2TM205

5) REMOVE NO.2 CARRIER SUB

- (1) Remove No.2 sun gear slowly.
※ When disassemble No.2 sun gear, be sure to keep vertical against ground with No.2 sun gear.

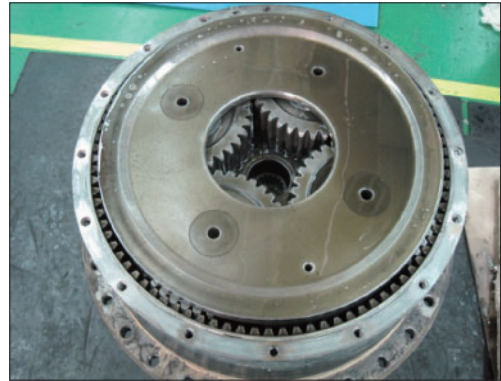

480L2TM206

- (2) Set eye bolt (M10) in No.2 carrier assy, pull-up slowly.



480L2TM207

6) REMOVE COUPLING

- (1) Remove coupling on motor spline.

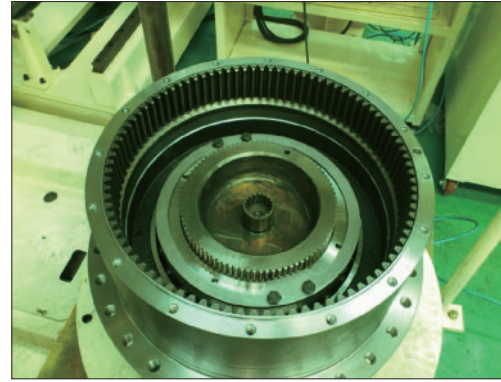

480L2TM208

7) REMOVE RING NUT AND LOCK PLATE

- (1) Remove hex head bolt (M12 × 20L) using torque wrench which is connecting ring nut and lock plate.
- (2) Remove lock plate from motor casing spline.

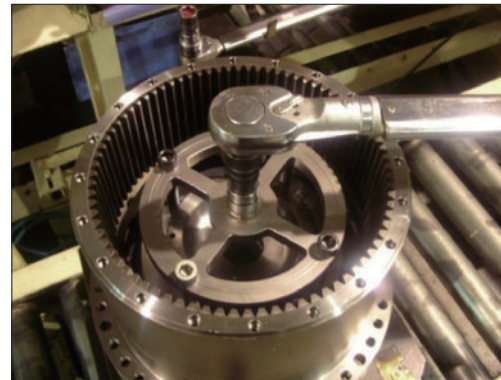

480L2TM209

- (3) Remove ring nut using designed tools.

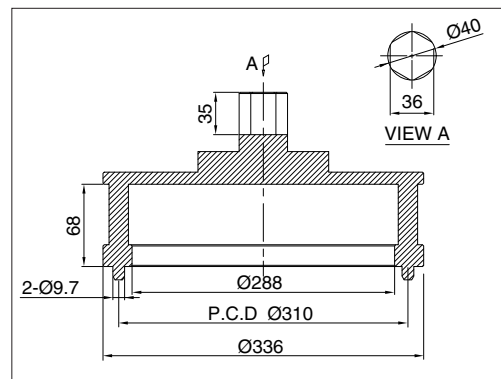

480L8TM03

8) DISASSEMBLE RING GEAR AND HOUSING

- (1) Set eye bolt (M20) in flange of housing, pulling ring gear and housing from motor.

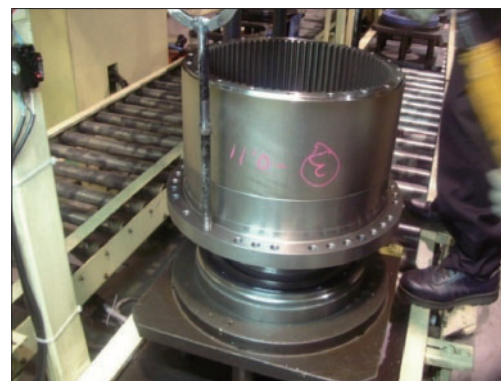

480L2TM210

(2) Put disassembled ring gear and housing on work table. Be sure to set floating seal upper side, and remove floating seal.

※ Do not re-use floating seal.

(3) Remove hex socket head bolt (M20×120L) connecting housing and ring gear using torque wrench.

(4) Put sharp tool into gap between ring gear and housing and tap it tenderly to separate gear and housing.

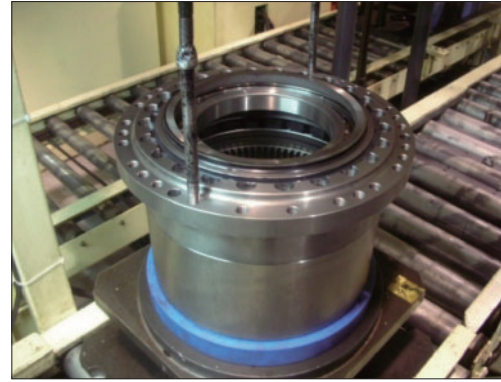

480L2TM212

9) DISASSEMBLE HOUSING COMPONENTS

Hex socket head bolt (M10×25L) connecting housing and seal cover using torque wrench, and remove seal cover.



480L2TM213

10) SEPARATE MOTOR CASING AND FLOATING SEAL

Pull floating seal in motor casing slowly and remove floating seal from motor casing.

※ Do not re-use floating seal.

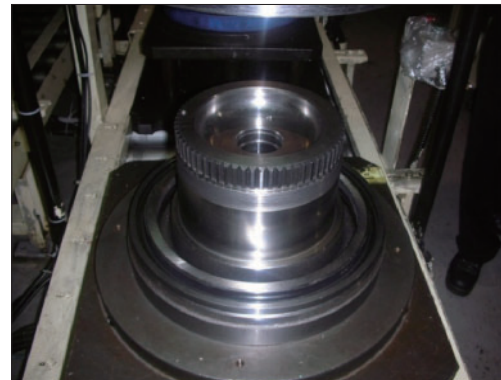

480L2TM211

11) NO.1 CARRIER ASS'Y DISASSEMBLE

(1) Put spring pin into spring pin hole using specially designed tool.



480L2TM214

- (2) Disassemble No.1 planetary gear, thrust washer, spring pin, needle bearing form No.1 carrier.
- ※ Do not re-use spring pin.



480L2TM215

12) NO.2 CARRIER ASS'Y DISASSEMBLE

- (1) Cut No.2 solid pin by pressing spring pin using press machine.
- ▲ **Be aware of scattering of components when operator use press machine.**
- (2) Disassemble No.2 planetary gear, thrust washer, spring pin, needle bearing from No.2 carrier.
- ※ Do not re-use spring pin.



480L2TM216

3. ASSEMBLY OF REDUCTION GEAR

1) GENERAL PRECAUTIONS

- (1) Clean all components with kerosene and dry them in shade. Remove all loctite with solvent.
Check the components.
Apply loctite #262 on thread of bolt-hex.socket head.
Be aware of dropping of parts on foot and safety accident.
Check the quantity of all parts in advance.
- (2) Check the abnormality of thrust washer like twist or wear.
- (3) Check the surface of every gear. Whether there is pitting or crack on them.
- (4) Rolling the bearing and check the rolling condition and the noise.
- (5) Check the surface of floating seal and crack of O-ring.

2) NO.1 CARRIER ASSEMBLY

- (1) Set No.1 carrier on stable and even place.
- (2) Put needle bearing in No.1 planetary gear and place thrust washer 2 pcs on both side of gear. Assemble gear in carrier.



480L2TM217

- (3) Align spring pin with No.1 carrier spring pin hole and assemble spring pin accordingly.



480L2TM218

- (4) Put spring pin into No.1 carrier using jig with force.



480L2TM221

- (5) Caulking both side of pressed spring pin 180° using caulking jig.

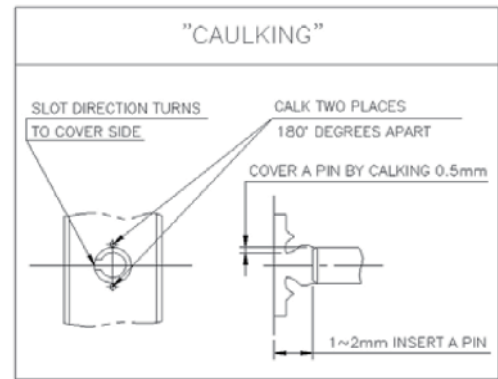

480L2TM219

3) NO.2 CARRIER ASSEMBLY

- (1) Set No.2 carrier on stable and even place.
- (2) Put needle bearing in No.2 planetary gear and place thrust washer 2 pcs on both side of gear. Assemble gear in carrier.
- (3) Align solid pin hole of spring pin and No.2 carrier spring pin hole. and assemble spring pin accordingly.
- (4) After assembly solid pin, put spring pin with force.
- (5) Caulking both sides of pressed spring pin 180° using caulking jig.



480L2TM220

4) FLOATING SEAL ASSEMBLY

Wipe O-ring side of floating seal and contact surface of floating seal of motor casing with oil applied lint free towel, and press fitting floating seal into motor casing with special jig.

- ※ Keep the floating seal vertical against ground.

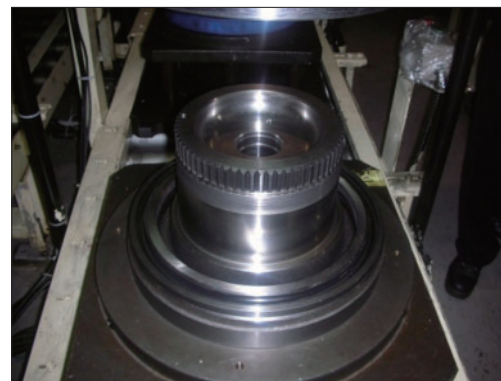

480L2TM222

5) HOUSING & MAIN BEARING ASSEMBLY

- (1) Heating and cleaning housing with 60~70°C temperature.
- (2) Set the housing on working table safely, press fitting main bearing into both side of housing.

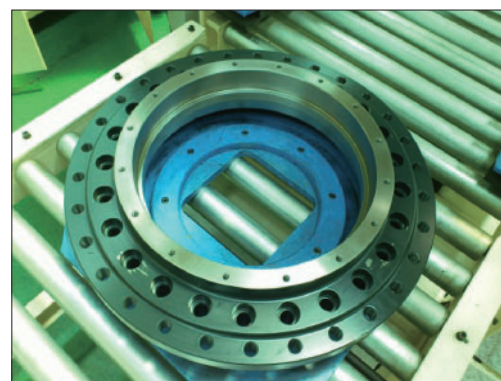

480L2TM224

6) SEAL COVER ASSEMBLY

Apply three bond #1194 on contact surface of housing and seal cover, tighten hex socket head bolt (M10×25L) with designed torque 6.3 ± 0.6 kgf · m (45.6 ± 4.3 lbf · ft) using torque wrench.



480L2TM225

7) HOUSING COMPONENTS AND RING GEAR ASSEMBLY

- (1) Apply three bond #1194 on the surface of ring gear and housing contact surface, tighten hex socket head bolt (M20×120L) with designed torque 53 ± 5.3 kgf · m (383 ± 38.3 lbf · ft) using torque wrench.
- (2) Wipe O-ring side of floating seal and contact surface of floating seal of seal cover with oil applied lint free towel, and press fitting floating seal into seal cover.

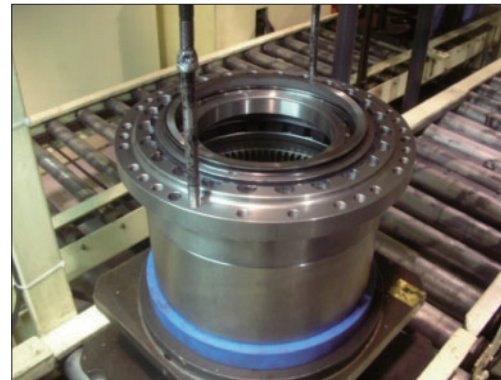

480L2TM223

8) MOTOR & ASSEMBLED HOUSING COMPONENTS ASSEMBLY

- (1) Set eye bolt (M20) in housing flange tap hole.
 - (2) Assemble assembled housing components on motor using hoist.
- ※ Be sure set eye bolt firmly to keep operator safe.

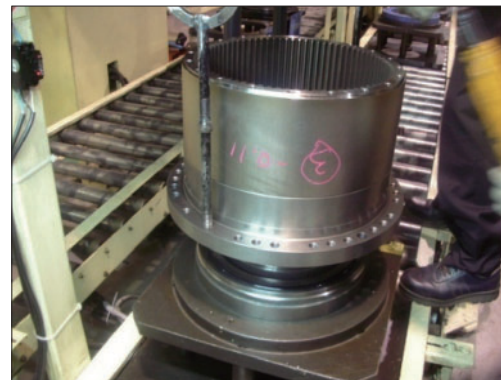

480L2TM226

9) NUT RING AND LOCK PLATE ASSEMBLY

- (1) Tighten nut ring with designed torque using torque wrench.
- (2) Set lock plate along with bolt hole of nut ring and assemble them.
- (3) Tighten hex head bolt (M12×20L) with designed torque 8.8 ± 0.9 kgf · m (63.6 ± 6.5 lbf · ft).

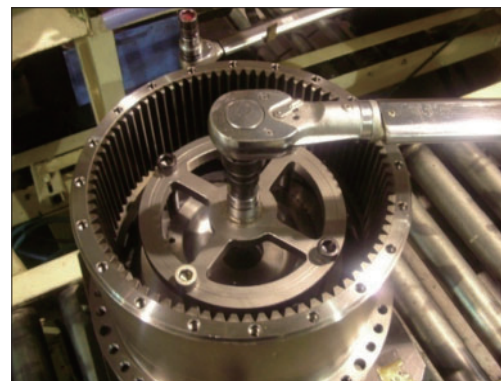

480L2TM228

10) COUPLING ASSEMBLY

Assemble coupling with motor's spline.

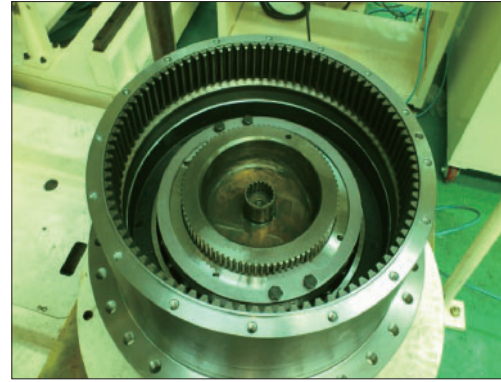

480L2TM230

11) NO.2 CARRIER SUB ASSEMBLY

(1) Set eye bolt (M10) in No.2 carrier assy, lift them using hoist and set down No.2 carrier assy into motor.



480L2TM229

※ To set the align valve ports, refer to right drawing.

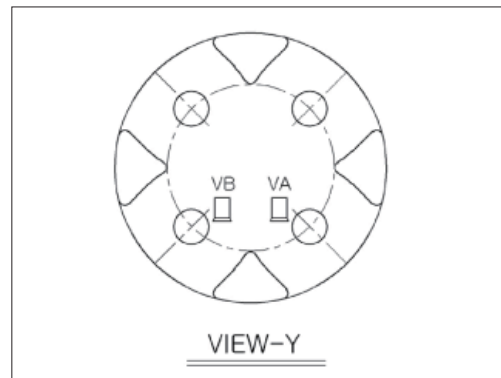

480L2TM231

(2) Assemble No.2 sun gear into No.2 carrier assy.

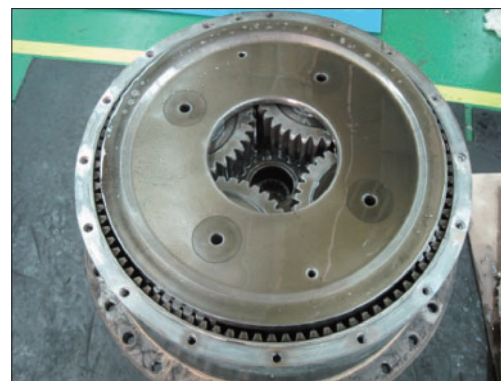

480L2TM227

12) NO.1 CARRIER SUB ASSEMBLY

- (1) Set eye bolt (M10) in No.1 carrier tap hole and set down No.1 carrier assy slowly.
- (2) Assemble No.1 sun gear and No.1 carrier assy.
- (3) Assemble thrust plate and carrier.

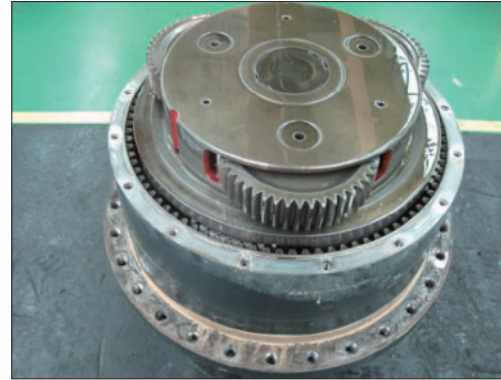

480L2TM232

13) COVER ASSEMBLY

- (1) Put parallel pin ($\varnothing 13 \times 20L$) into parallel pin hole of ring gear with rubber hammer.
- (2) Apply three bond #1194 on cover contacting surface of ring gear and assemble cover.
- (3) Tighten 16 of hex socket head bolt (M12 \times 35L) with designed torque $14.3 \pm 1.4 \text{ kgf} \cdot \text{m}$ ($103 \pm 10.1 \text{ lbf} \cdot \text{ft}$) using torque wrench.



480L2TM233

14) PUTTING GEAR OIL

- (1) Put gear oil $12 \pm 0.5L$ through drain port and check the level gage.
- (2) Tighten oil plug with torque $10 \pm 1.0 \text{ kgf} \cdot \text{m}$ ($72.3 \pm 7.2 \text{ lbf} \cdot \text{ft}$).

TRAVEL DEVICE (TYPE 3)

1. REMOVAL AND INSTALL

1) REMOVAL

- (1) Swing the work equipment 90° and lower it completely to the ground.
- (2) Operate the control levers and pedals several times to release the remaining pressure in the hydraulic piping.
- (3) Loosen the breather slowly to release the pressure inside the hydraulic tank.

▲ Escaping fluid under pressure can penetrate the skin causing serious injury.

- ※ When pipes and hoses are disconnected, the oil inside the piping will flow out, so catch it in oil pan.
- (4) Remove the track shoe assembly.
For details, see removal of track shoe assembly.
 - (5) Remove the cover.
 - (6) Remove the hose.
 - ※ Fit blind plugs to the disconnected hoses.
 - (7) Remove the bolts and the sprocket.
 - (8) Sling travel device assembly (1).
 - (9) Remove the mounting bolts (2), then remove the travel device assembly.
 - Weight : 360 kg (790 lb)
 - Tightening torque : 57.9 ± 8.7 kgf · m
(419 ± 62.9 lbf · ft)

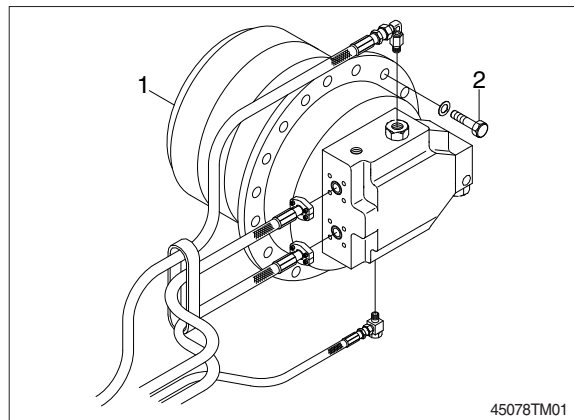

2) INSTALL

- (1) Carry out installation in the reverse order to removal.
- (2) Bleed the air from the travel motor.
 - ① Remove the air vent plug.
 - ② Pour in hydraulic oil until it overflows from the port.
 - ③ Tighten plug lightly.
 - ④ Start the engine, run at low idling, and check oil come out from plug.
 - ⑤ Tighten plug fully.
- (3) Confirm the hydraulic oil level and check the hydraulic oil leak or not.

2. TRAVEL MOTOR (1/2)

1) STRUCTURE

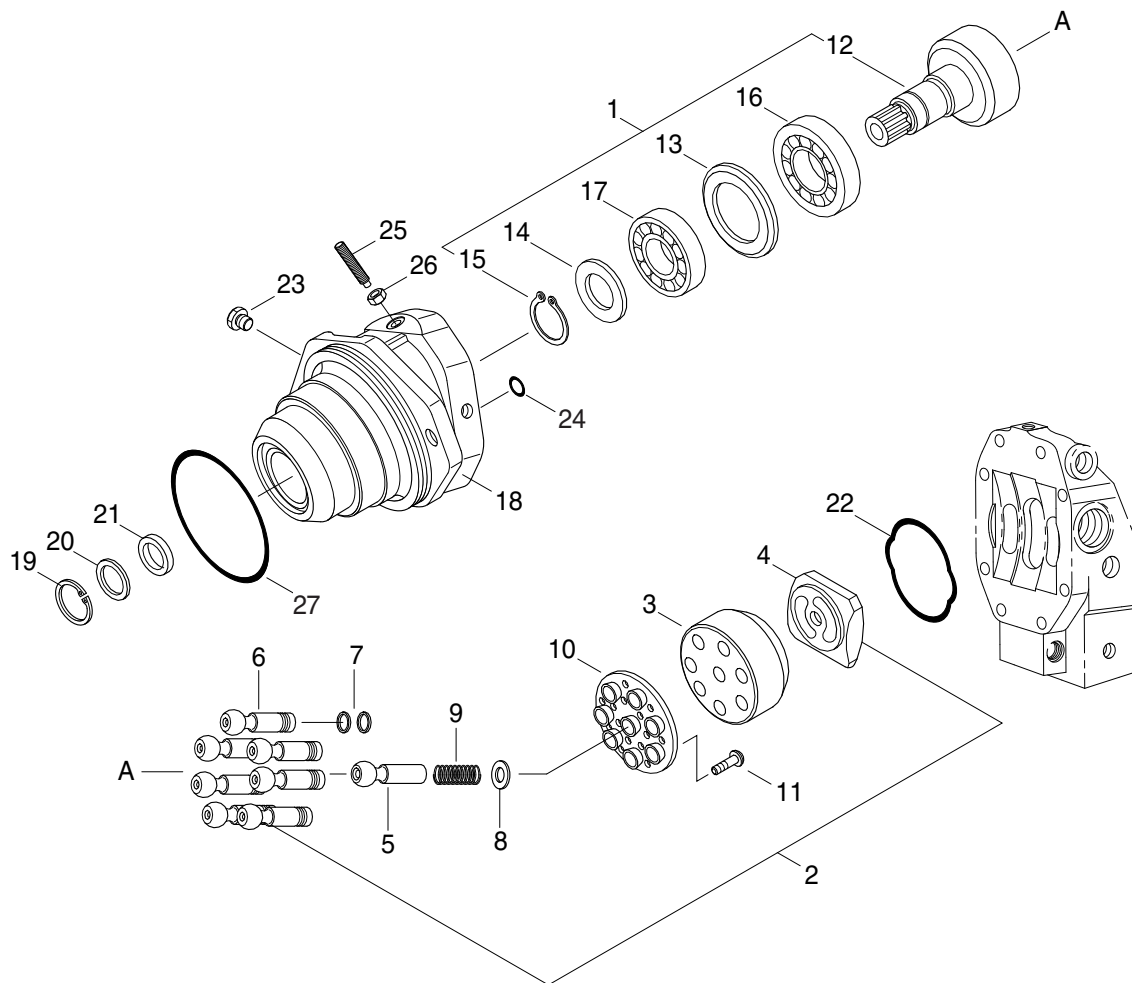

450A8TO02

1	Rotary group	10	Retainer plate	19	Retainer ring
2	Hyd section rotary	11	Screw	20	Shaft seal ring
3	Cylinder	12	Drive shaft	21	Back up plate
4	Control lens	13	Shim	22	O-ring
5	Center pin	14	Back up plate	23	Locking screw
6	Piston	15	Retainer ring	24	O-ring
7	Steel ring	16	Roller bearing	25	Threaded pin
8	Adjustment shim	17	Roller bearing	26	Seal lock nut
9	Pressure spring	18	Housing	27	O-ring

TRAVEL MOTOR (2/2)

· Control part

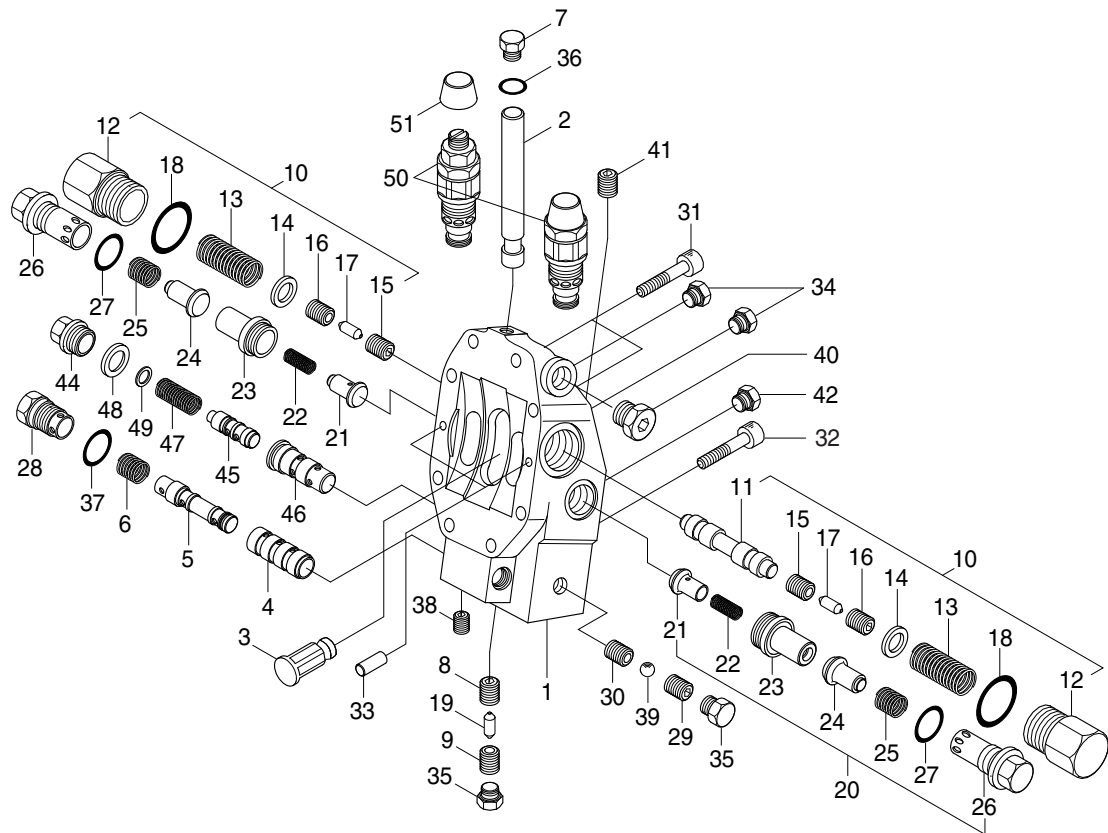

450A8TO03

- | | | | | | |
|----|-------------------|----|-----------------|----|------------------------|
| 1 | Port plate | 18 | O-ring | 35 | Locking screw |
| 2 | Position piston | 19 | Throttle pin | 36 | O-ring |
| 3 | Position turnnion | 20 | Valve | 37 | O-ring |
| 4 | Control bushing | 21 | Poppet valve | 38 | Brake off pin |
| 5 | Control piston | 22 | Pressure spring | 39 | Ball |
| 6 | Pressure spring | 23 | Seat poppet | 40 | Locking screw |
| 7 | Locking screw | 24 | Poppet valve | 41 | Brake off pin |
| 8 | Throttle screw | 25 | Pressure spring | 42 | Locking screw |
| 9 | Throttle screw | 26 | Locking screw | 43 | Pressure control valve |
| 10 | Brake valve | 27 | O-ring | 44 | Locking screw |
| 11 | Brake piston | 28 | Locking screw | 45 | Control piston |
| 12 | Locking screw | 29 | Valve screw | 46 | Control bushing |
| 13 | Pressure spring | 30 | Bushing | 47 | Pressure spring |
| 14 | Washer | 31 | Socket screw | 48 | O-ring |
| 15 | Throttle screw | 32 | Socket screw | 49 | Shim |
| 16 | Throttle screw | 33 | Cylinder pin | 50 | Relief pressure valve |
| 17 | Throttle pin | 34 | Locking screw | 51 | Cap |

2) TOOLS AND TIGHTENING TORQUE

(1) Tools

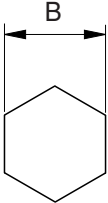
Tool name	Remark	
Allen wrench	2.5	
	4	
	6	
	8	
	10	
	14	
Socket for socket wrench, spanner	19	
Torque wrench	Capable of tightening with the specified torques.	
Pliers	-	
(-) Driver	150 mm	
Plastic and iron hammer	Wooden hammer allowed. Nominal 1 or so	
Steel rod approx	7×7×200 mm	
Monkey wrench	-	
Oil seal inserting jig	-	
Bearing pliers	-	
Seal tape	-	
Press (0.5 ton)	-	
Oil stone	-	
Bearing assembling jig	-	
Liquid packing	Loctite #577	
Screw lock	Loctite #243	

(2) Tightening torque

Part name	Item	Size	Torque	
			kgf·m	lbf·ft
Locking screw	11	M 6×20	1.0	7.4
Locking screw	13	M26×1.5	7.0	50.9
Locking nut	18	M12	7.0	50.9
Socket head screw	20, 21	M16×90	-	-
Socket head screw	22	M16×120	-	-
Locking screw	24	M14×1.5	3.0	22
Locking screw	25	M10×1	1.0	7
Locking screw	30	M27×2.0	9.1	66
Locking screw	32	M16×1.5	7.0	50.9

3) DISASSEMBLY

(1) General precautions

- ① Before disassembling the motor, check the items to be inspected and, for remedy against trouble, closely examine the nature of the trouble, so that the motor can be disassembled effectively.
- ② To disassemble the motor, use the disassembling procedures described in section 2) and select a clean place.
- ③ Place a rubber or vinyl sheet or other such protective materials on your working bench to protect the surface of the motor to be serviced.
- ④ During disassembly, give a match mark to the mating surfaces of each part.
- ⑤ Arrange removed parts in order so that they will not become damaged or missing during disassembly.
- ⑥ Once seals have been disassembled, they should be replaced even if damage is not observed. Have replacement seals ready on hand before starting your disassembling job.

(2) Seal kit and component groups

① Attention

Observe the following notices when carrying out repair work at hydraulic aggregates!



② Close all ports of the hydraulic aggregates.

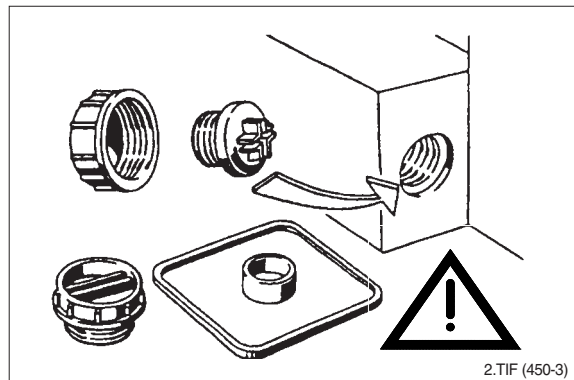

③ Replace all seals.

Use only original spare parts.

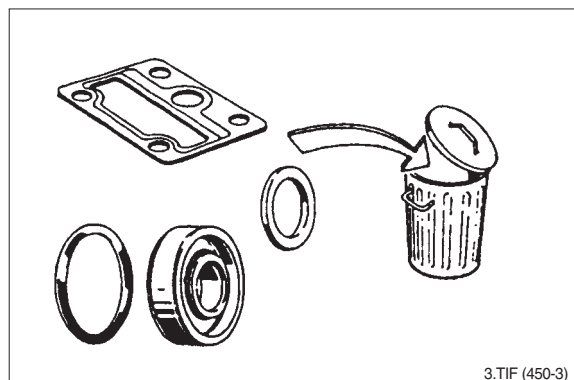

④ Check all seal and sliding surfaces for wear.

Rework of sealing area for example with abrasive paper can damage surface.

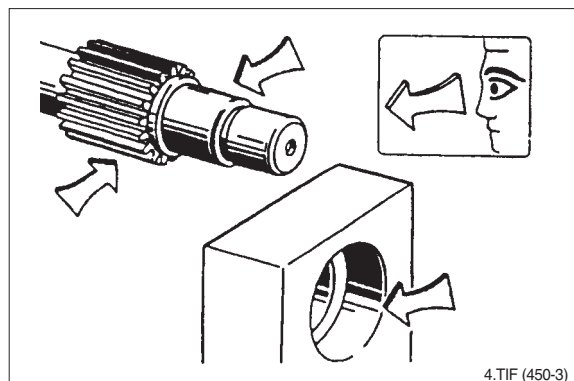

- ⑤ Fill up hydraulic aggregates with hydraulic oil before start-up.

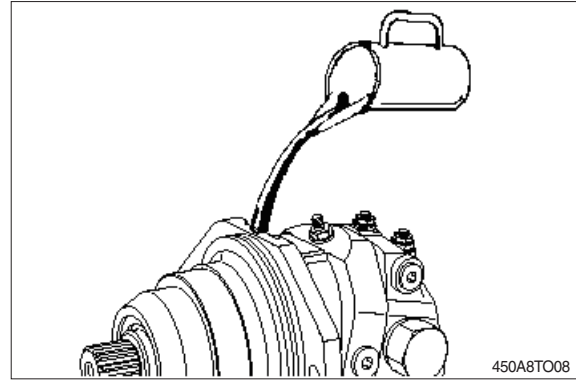

- ⑥ Seal kit for drive shaft.

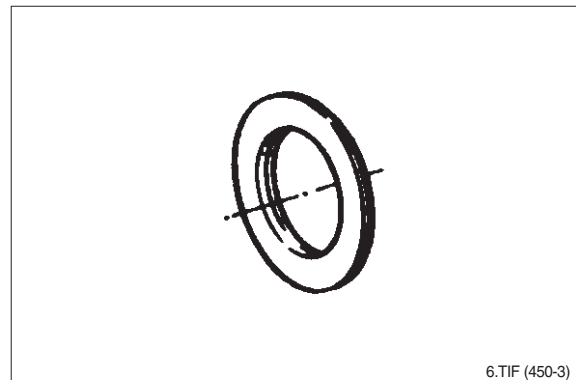

- ⑦ External seal kit.

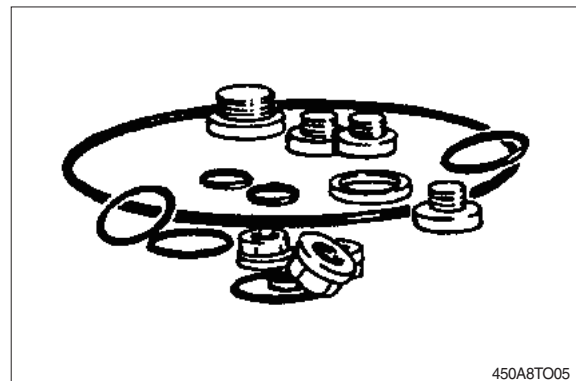

- ⑧ Housing.

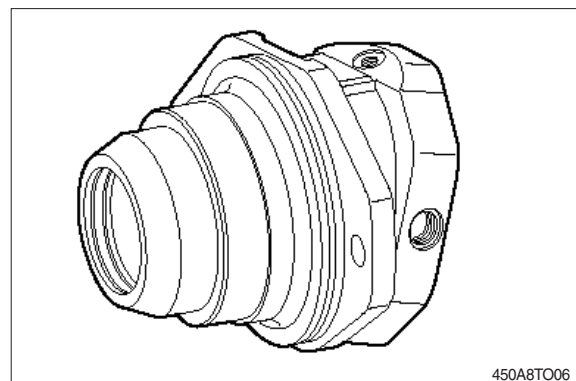

⑨ Complete rotary group.

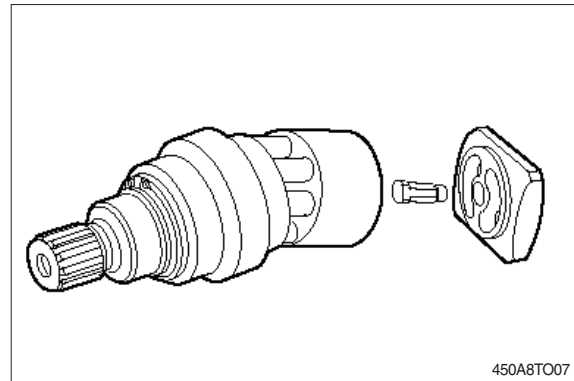

⑩ Port plate with control piston and counter-balance valve.

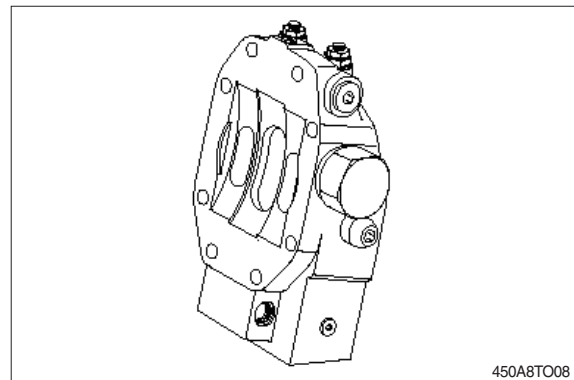

⑪ Relief valve/Make up check valve

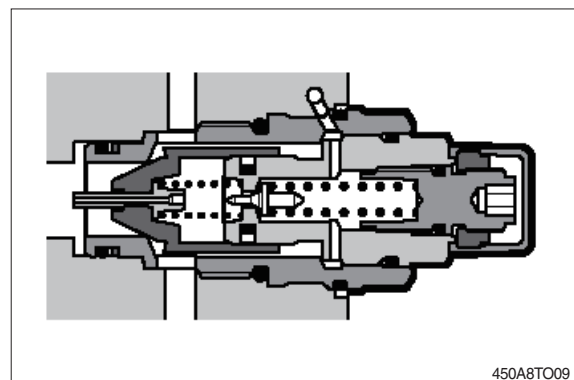

⑫ Replace seal nut.
First measure and record setting height.

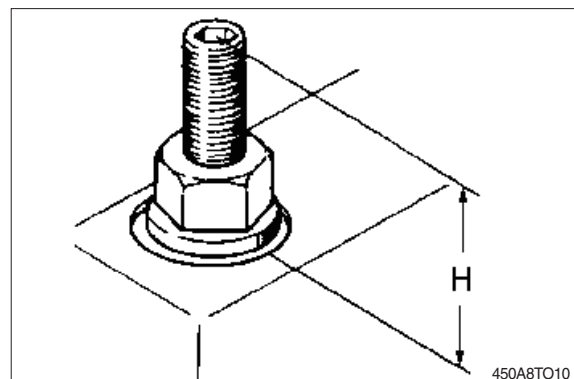

- ⑬ When tightening, counterhold setting screw, then check setting height.

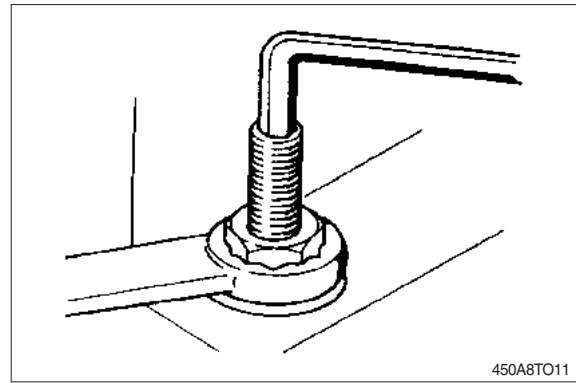

(3) Sealing the drive shaft

- ① Protecting the drive shaft.
Remove retaining ring and shim.

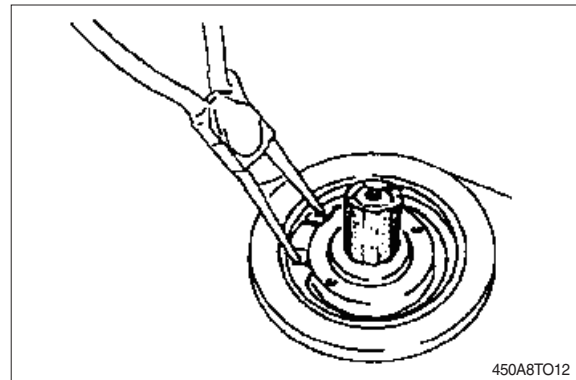

- ② Screw in sheet metal screw into the holes fitted with rubber.
Pull out seal with pliers.

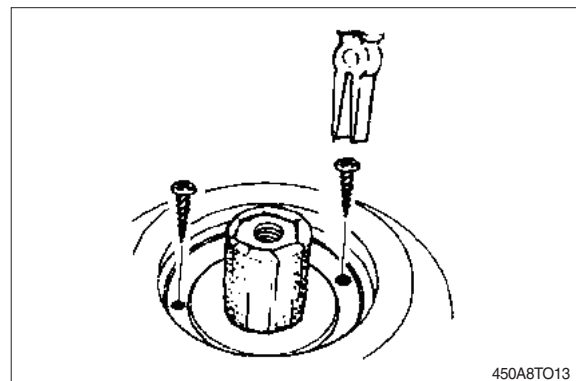

- ③ Press in shaft seal and shim with bush to stop.
※ Pay attention to pressing depth!
★ Mark for pressing depth.
Assemble retaining ring.

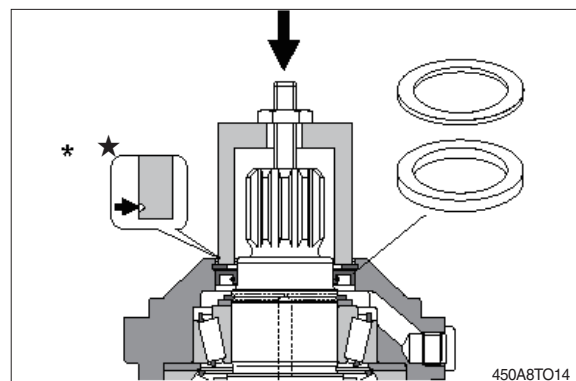

(4) Sealing of the control parts

- ① HZ-Controller
- ※ O-ring, O-ring groove, housing.

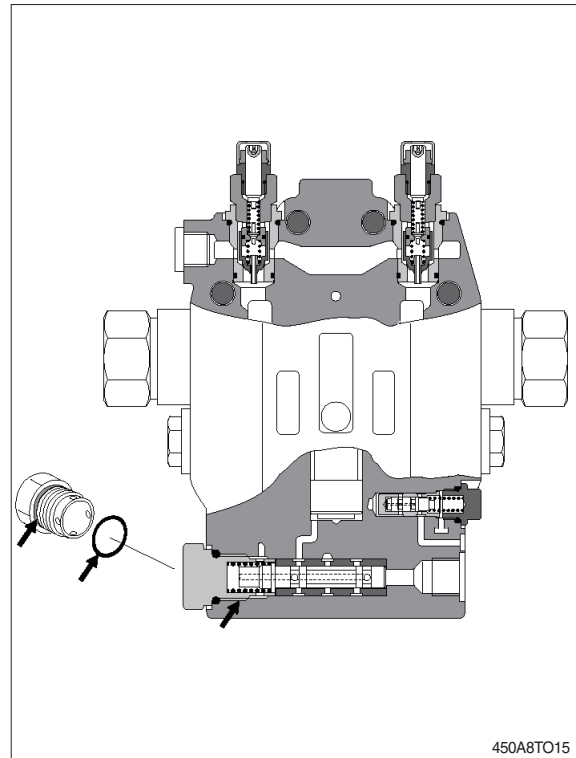

(5) Sealing of the relief valve

- ① Remove relief valve.

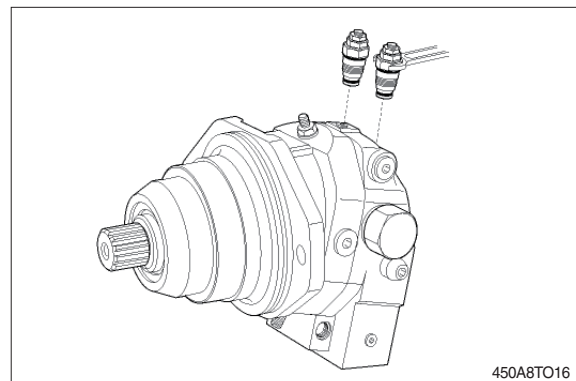

- ② Inspect O-ring.

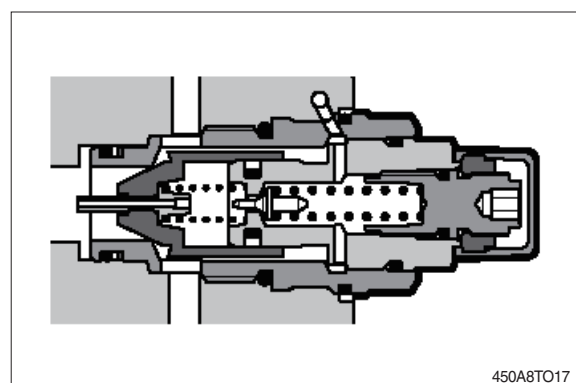

(6) Disassembly of the port plate

- ① Note dimension x .
Remove Q_{\min} -screw.

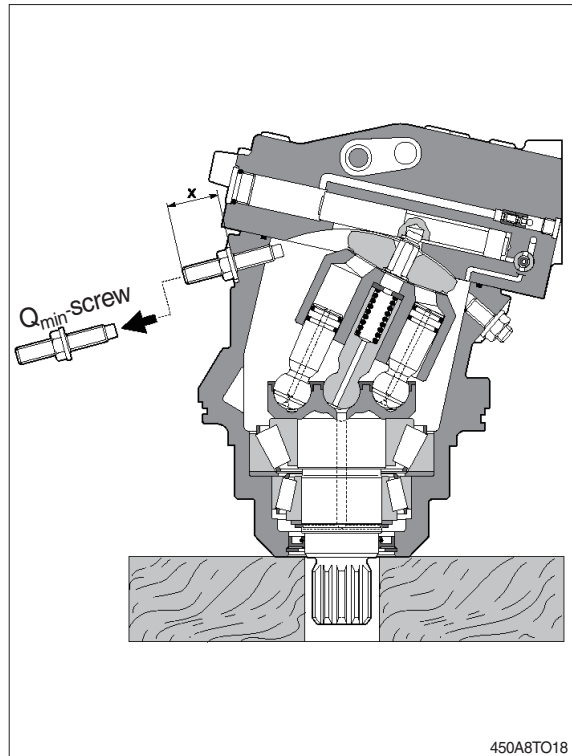

- ② For disassembly of the port plate, swivel always rotary group to zero position. Piston rings to hang out of the cylinder boring. Swivel rotary group to zero position with screw Q_{\max} .

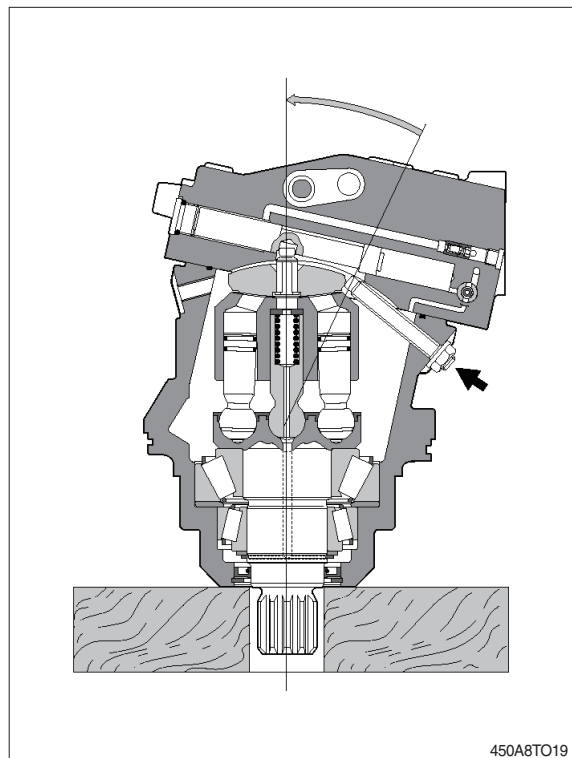

- ③ Port plate
Mark position. Loosen screws.
Removal.

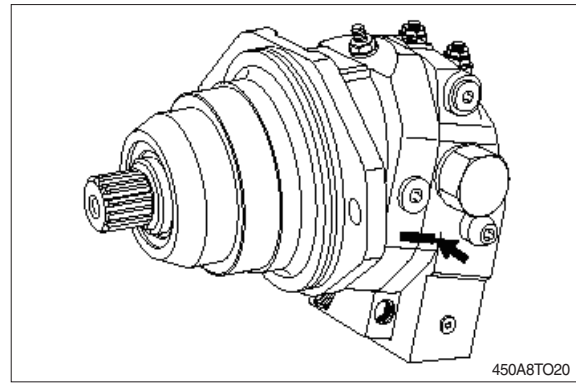

- ④ Check O-ring.
※ Stick new O-ring with some grease. Do
not swivel rotary group. Piston rings to
hang out from the cylinder boring.

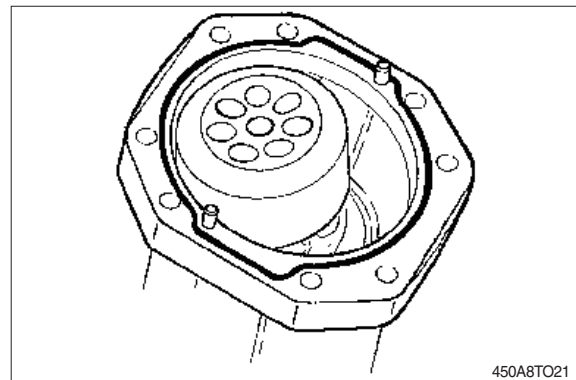

(7) Remove rotary group

- ① Screw in threaded pin into center pin.
Fix the cylinder with disc and lock nut.
Size : M8×105 mm

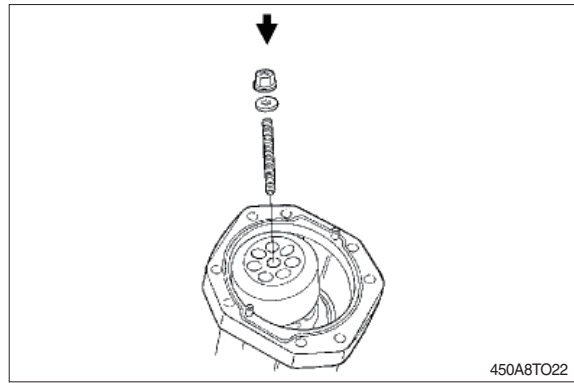

- ② Press out rotary group!
※ If the bearings are used again do not hit on the drive shaft.

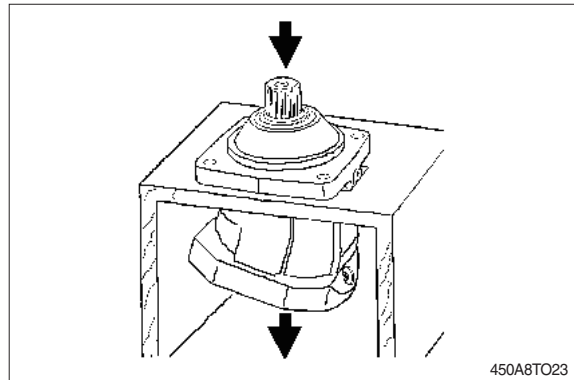

(8) Exchanging of the rotary group

- ① Remove fixing screw (cylinder).
Remove cylinder.

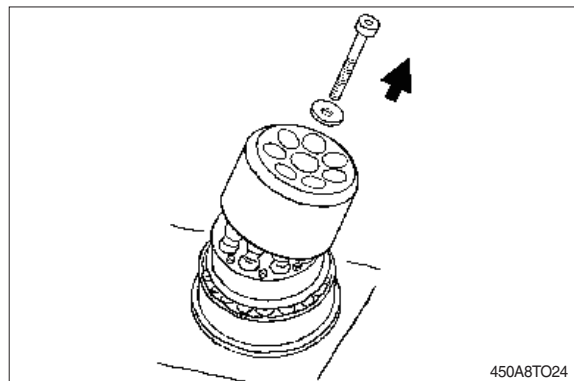

- ② Disassemble retaining plate.
※ Screws are glued. Use Torx-tools.

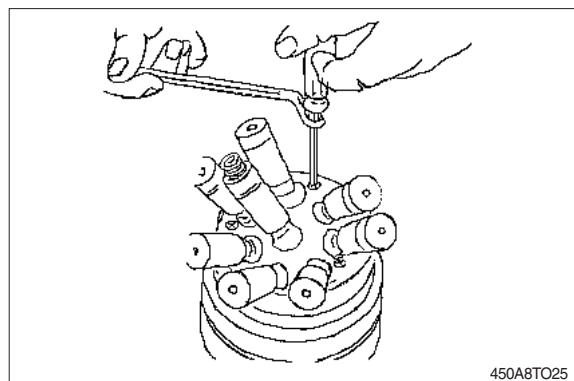

4) ASSEMBLY

(1) General precautions

- ① Reassemble in a work area that is clean and free from dust and grit.
- ② Handle parts with bare hands to keep them free of liny contaminates.
- ③ Repair or replace the damaged parts.
Each parts must be free of burrs its corners.
- ④ Do not reuse O-rings, oil seal and floating seal that were removed in disassembly.
Provide the new parts.
- ⑤ Wash all parts thoroughly in a suitable solvent.
Dry thoroughly with compressed air.
Do not use the cloths.
- ⑥ When reassembling oil motor components of motor, be sure to coat the sliding parts of the motor and valve with fresh hydraulic oil. (NAS class 9 or above)
- ⑦ Use a torque wrench to tighten bolts and plugs, to the torque specified as follows.

(2) Rotary group assembly

- ① Rotary group completely assembled ready for assembly.

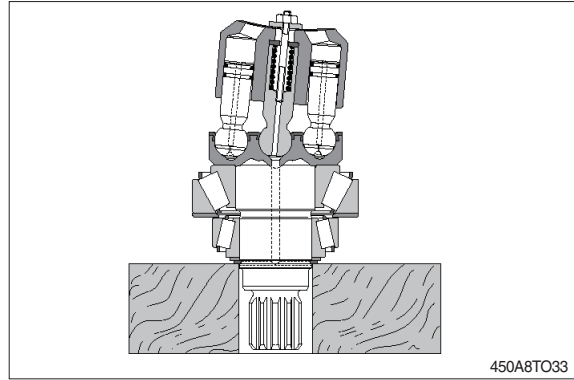

- ② Place assembly sleeve.

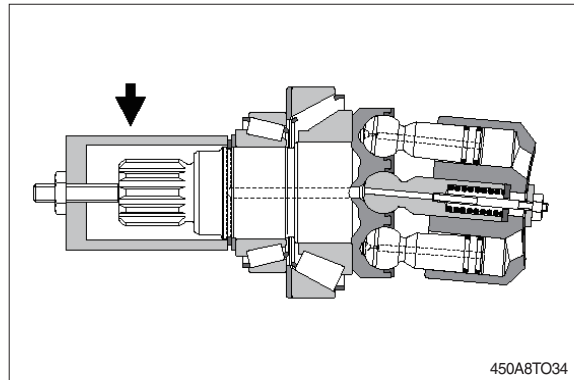

- ③ Warm up housing to 80°C.

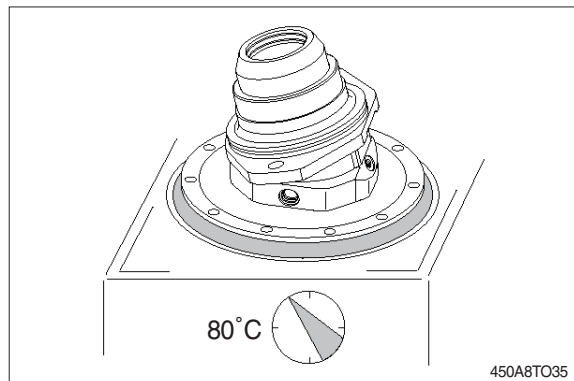

- ④ Insert rotary group into housing to seat position.

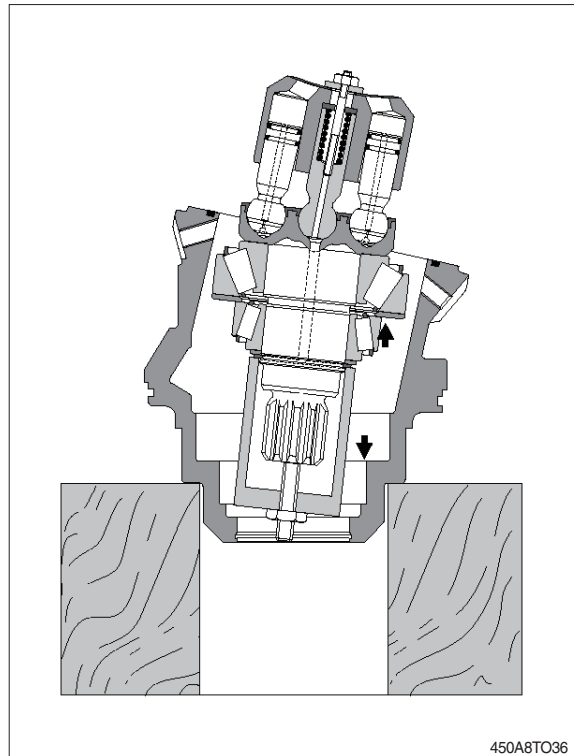

- ⑤ Fix zero position of cylinder with Q_{max} screw.
- a. Disassemble cylinder fixing screw.
 - b. Insert O-ring.

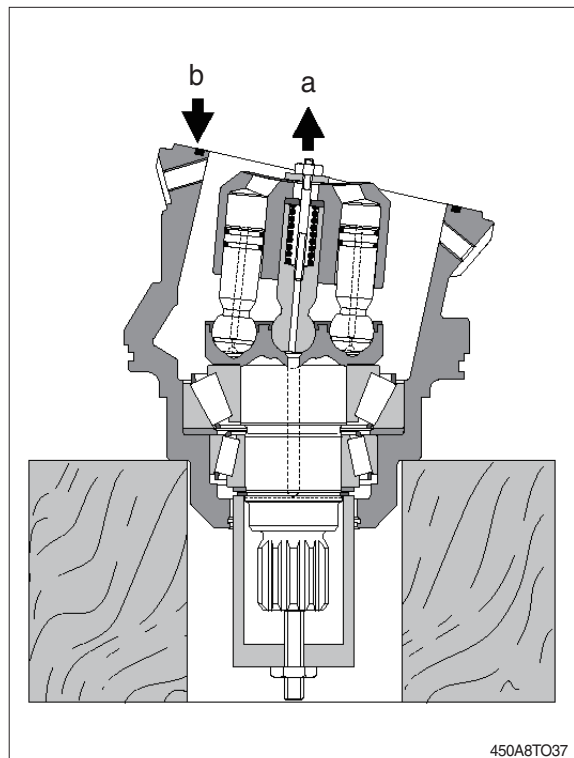

(3) Rotary group adjustment

- ① Determine cylinder swivel range to max angle with screw.

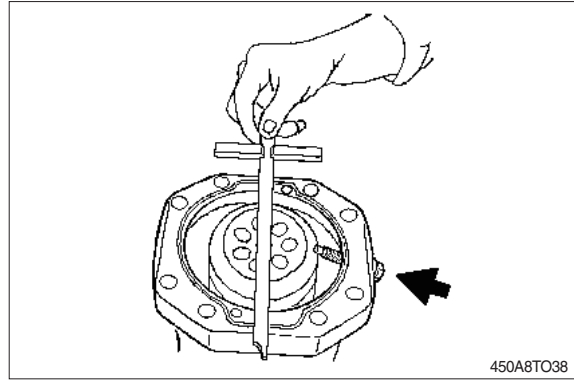

- ② *Disc

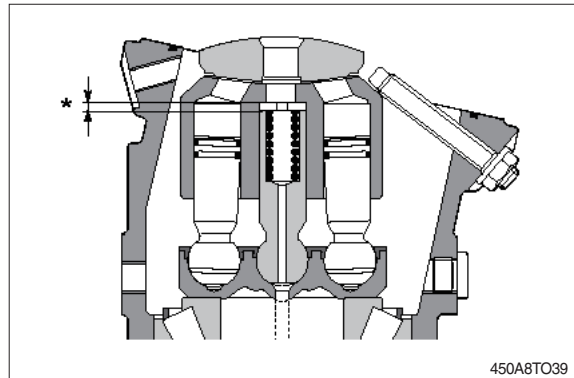

- ③ Place centering disc.

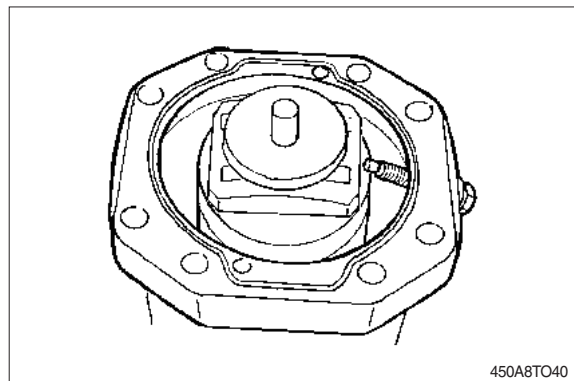

- ④ Mount measuring device.

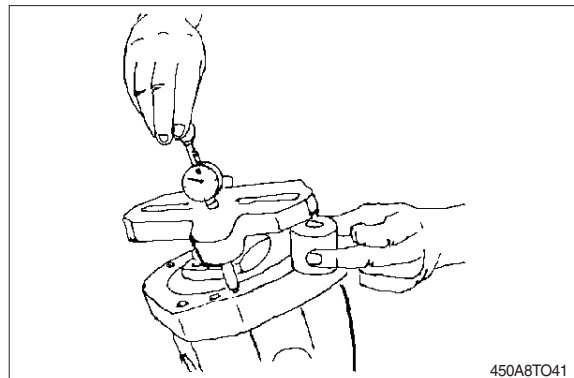

⑤ Check dimension X.

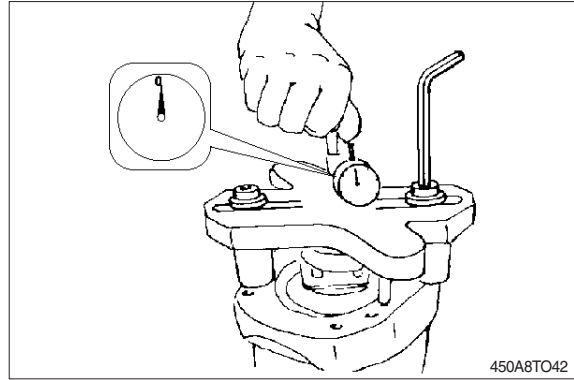

(4) Assembly of the port plate

- ※ Stick control lens in sliding surface with grease. Assembly in reversal order. Mount port plate.

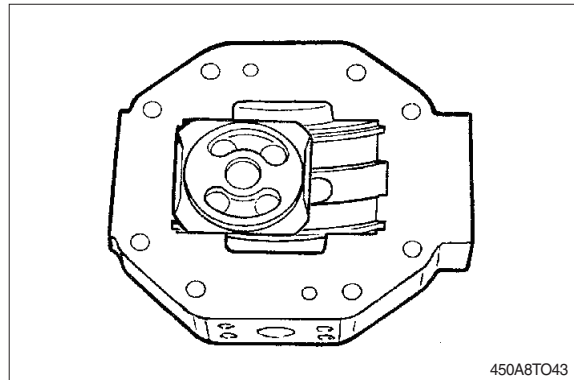

① Assembly port plate.

- ※ Take care of assembly design! Tighten fixing screws with torque.
 - Set Q_{min} -screw to dimension*.
 - Assemble plug.
 - Remove assembly sleeve.

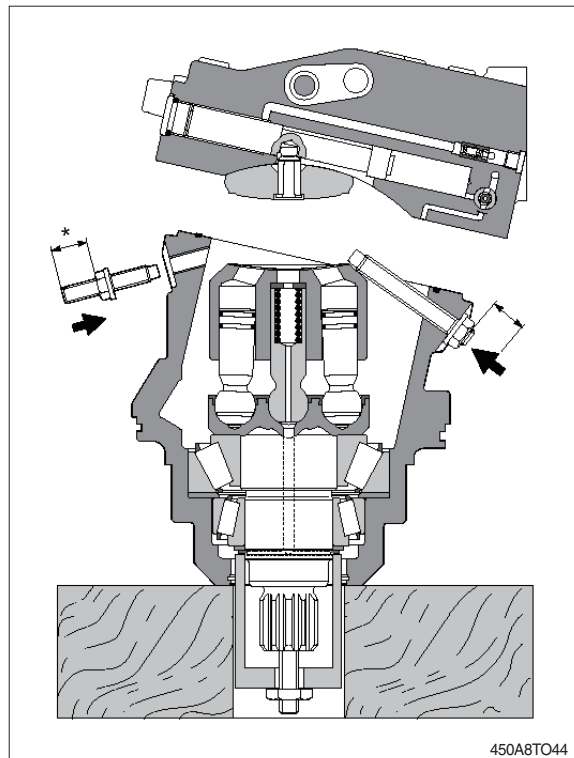

- ② Assemble shaft seal, disc and safety ring. Press-in with assembly sleeve.
※ Take care of press-in depth.

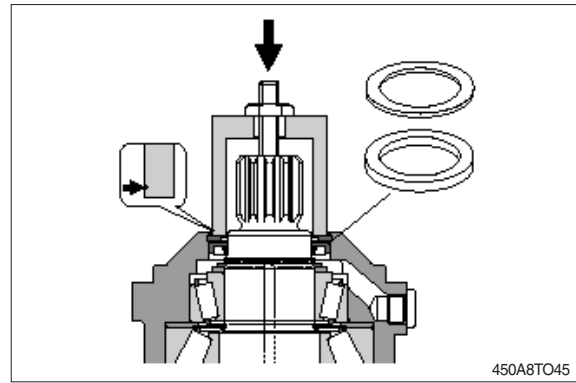

3. REDUCTION GEAR

1) STRUCTURE

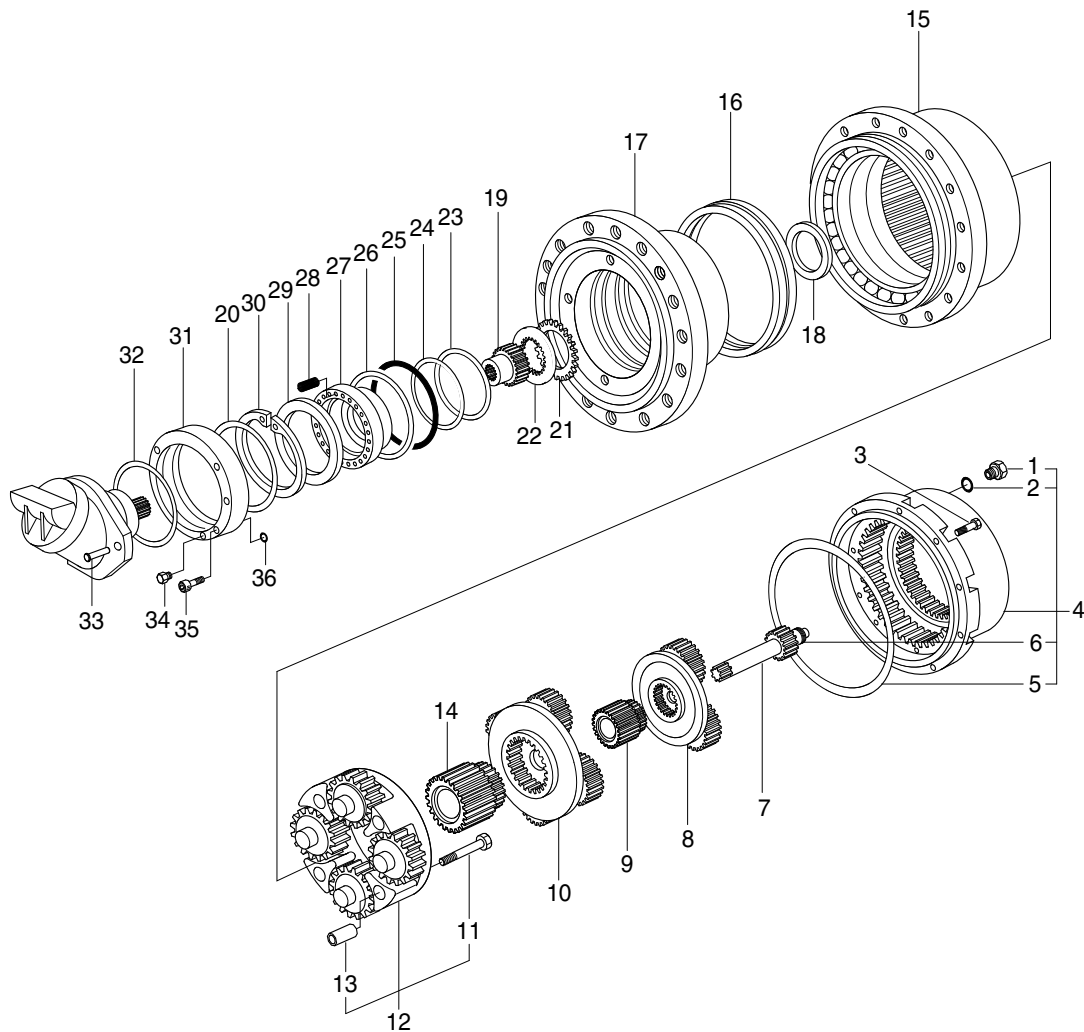

450A8TR01

- | | | | | | |
|----|----------------------|----|---------------|----|-------------|
| 1 | Washer | 13 | Bushing | 25 | O-ring |
| 2 | Breather plug | 14 | Sun gear | 26 | Spiral ring |
| 3 | Screw | 15 | Housing | 27 | Piston |
| 4 | Cover set | 16 | Lifetime seal | 28 | Spring |
| 5 | O-ring | 17 | Hub | 29 | Spacer |
| 6 | Pad | 18 | Spacer | 30 | Circlip |
| 7 | Sun gear | 19 | Brake shaft | 31 | Flange |
| 8 | Reduction assy (1st) | 20 | O-ring | 32 | O-ring |
| 9 | Sun gear | 21 | Brake disc | 33 | Screw |
| 10 | Reduction assy (2nd) | 22 | Steel ring | 34 | Plug |
| 11 | Screw | 23 | Back up ring | 35 | Screw |
| 12 | Reduction assy (3rd) | 24 | O-ring | 36 | O-ring |

2) DISASSEMBLING

Initial inspection of the gears and the travel motor, can be made without disassembling the track and the gearmotor from the machine.

Prior to disassembling make sure that the oil is discharged, unscrew and remove the 2 screws (33), and remove the travel motor and the O-ring (32).

- (1) Unscrew the 8 socket head screws (3) and remove the motor flange from the flanged hub (17).

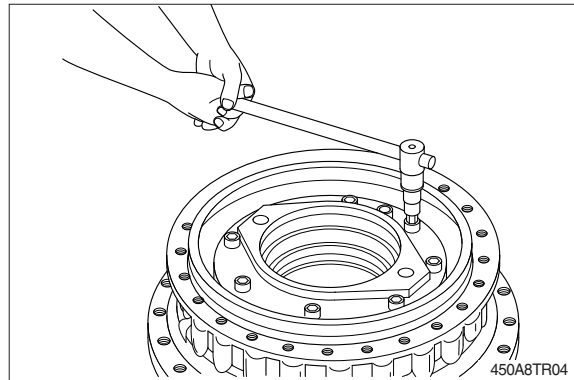

- (2) Remove the O-ring (20) from its groove in the motor flange (31).

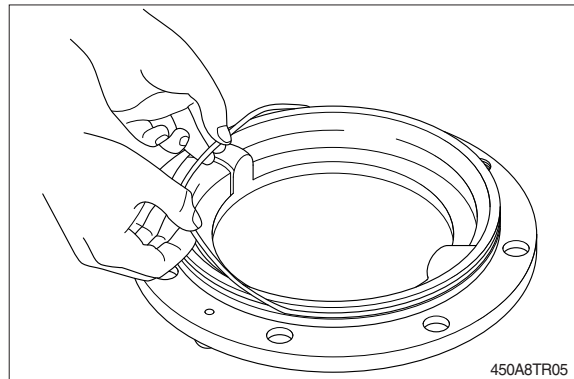

- (3) Remove the O-ring (36) from its groove in the flanged hub (17).

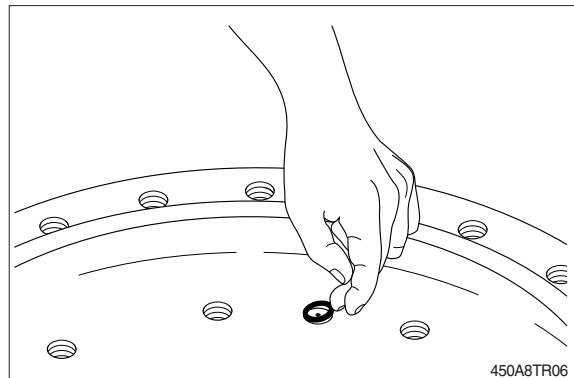

(4) After having placed the disc on the spring retainer (29), fix the pusher on the flanged hub (17) as shown in the scheme by screwing the threaded bar, push the disc on the retainer, thus removing the force of the springs (28) on the circlip (30) and allowing its disassembling.

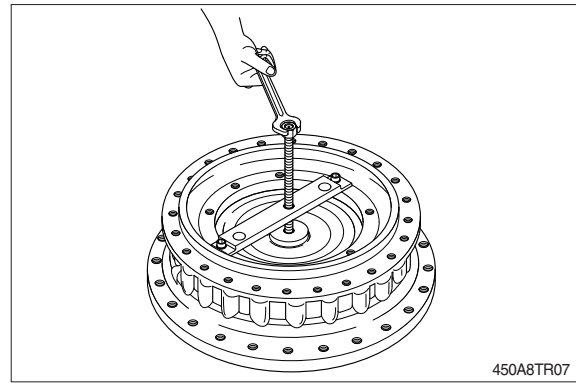

(5) Using pliers remove the circlip (30) from its groove in the flanged hub (17).

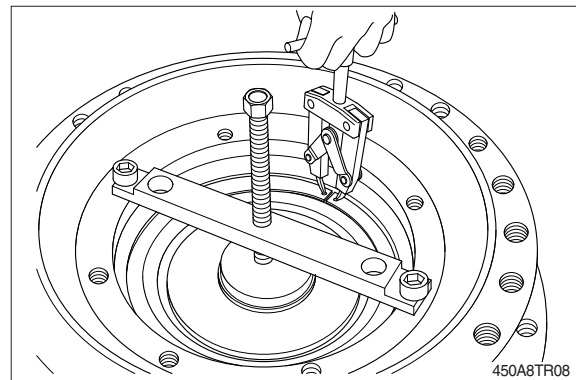

(6) Disassemble the equipment from the flanged hub (17) and remove the circlip (30).

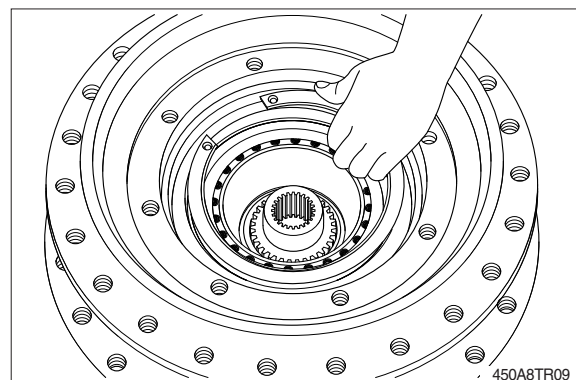

(7) Remove the springs retainer (29).

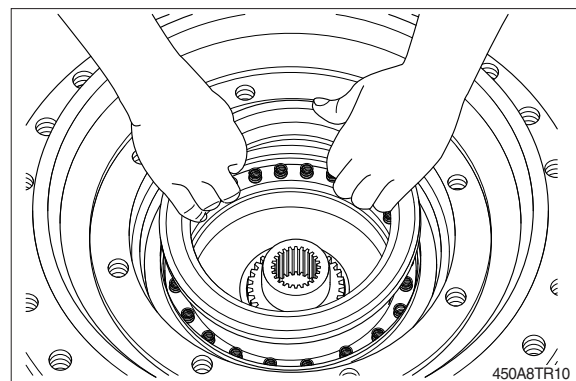

(8) Remove the springs (28) from their grooves.

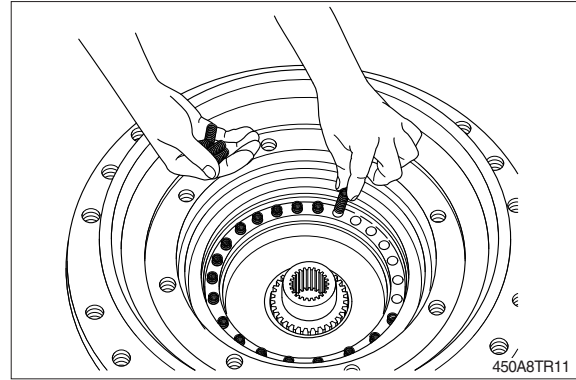

(9) Using pliers remove the brake piston (27).
※ To get it easier, pumping compressed air into the brake port hole.

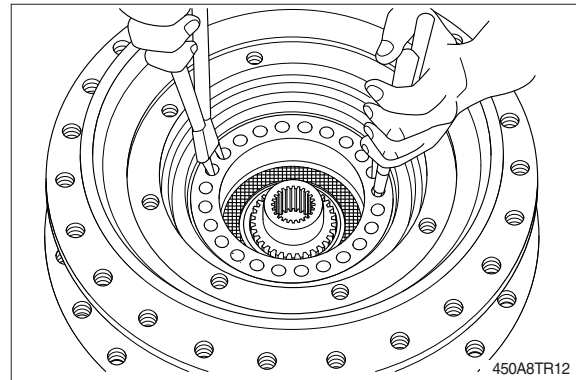

(10) Remove the brake shaft (19).

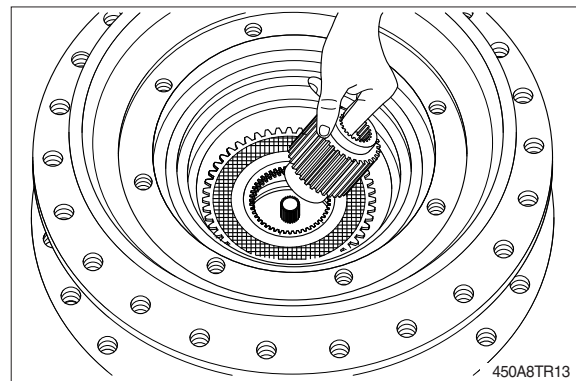

(11) Remove brake discs pack (21, 22).

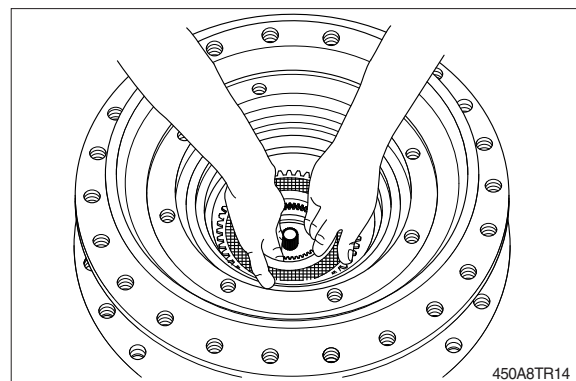

(12) Remove the O-rings (24,25) and the backup rings (23, 26) from their grooves in the flanged hub (17).

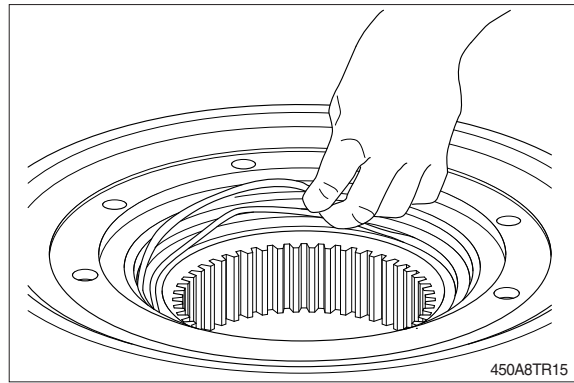

(13) Turn the gearbox around, unscrew and remove the 2 plugs (2) and the 2 washers (1) from the end cover (4).

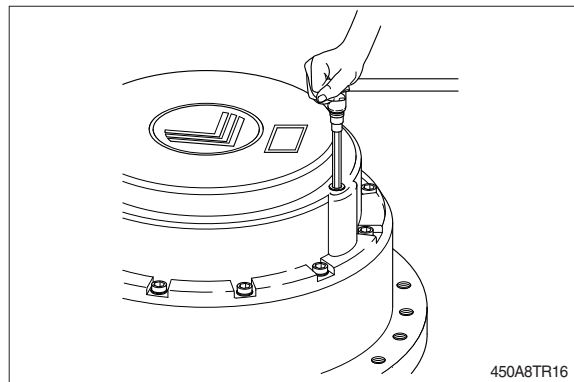

(14) Unscrew and remove the 16 socket head screws (3).

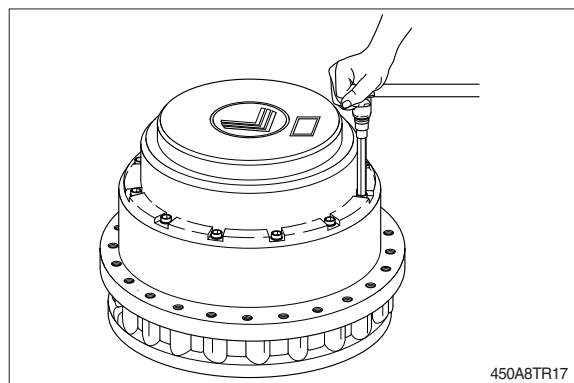

(15) By means of a puller remove the end cover (4).

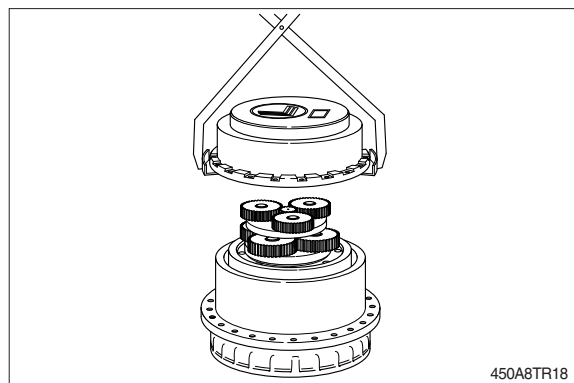

(16) Remove the O-ring (5) from its groove in the end cover (4).

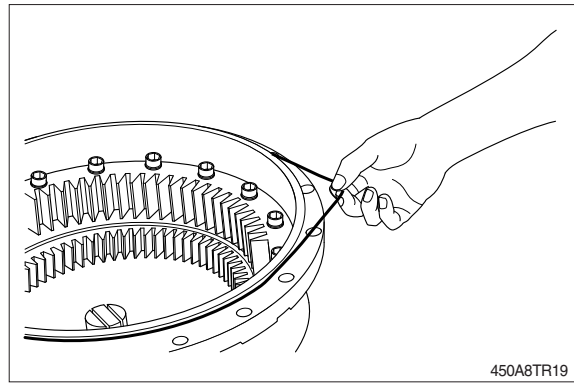

(17) Remove the 1st stage sun gear (7).

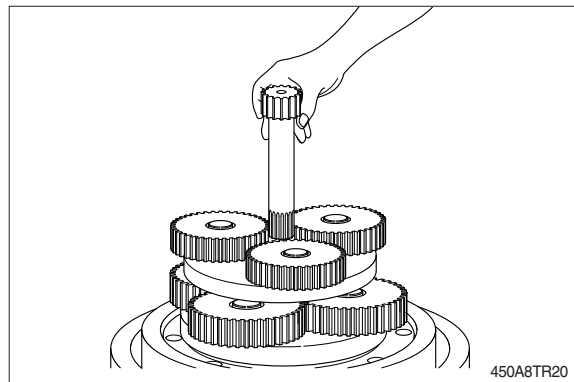

(18) Remove the 1st reduction assembly (8).

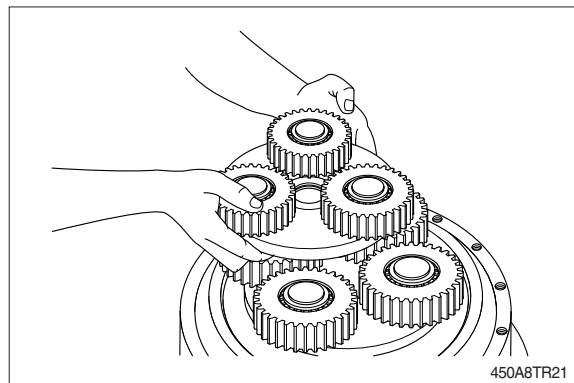

(19) Remove the 2nd stage sun gear (9).

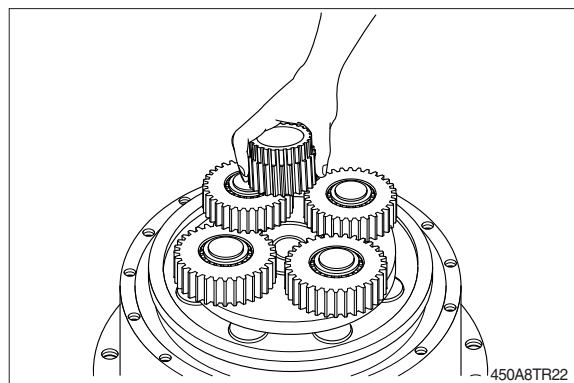

(20) Remove the 2nd reduction assembly (10).

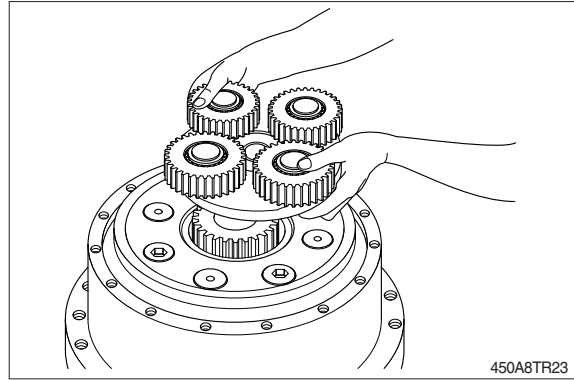

(21) Remove the 3rd stage sun gear (14).

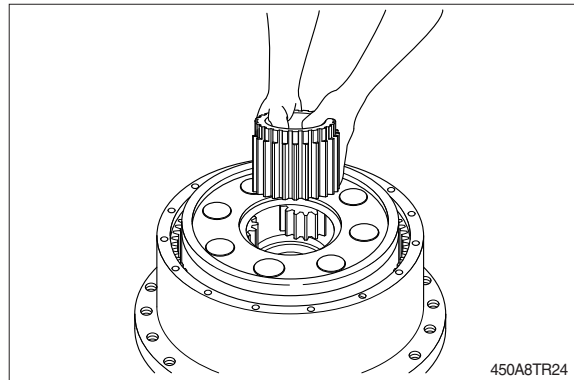

(22) Unscrew the 4 socket head screws (11), fixing the 3rd reduction assembly (12) to the flanged hub (17).

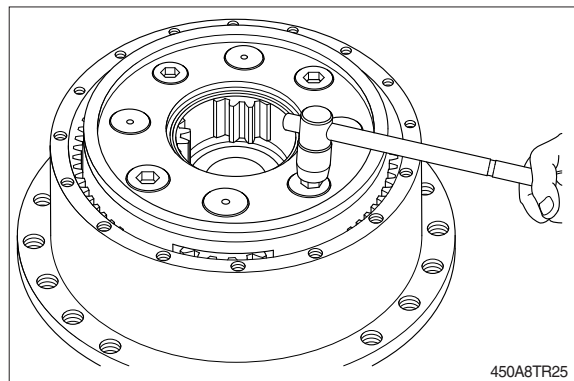

(23) Remove the 4 screws (11).

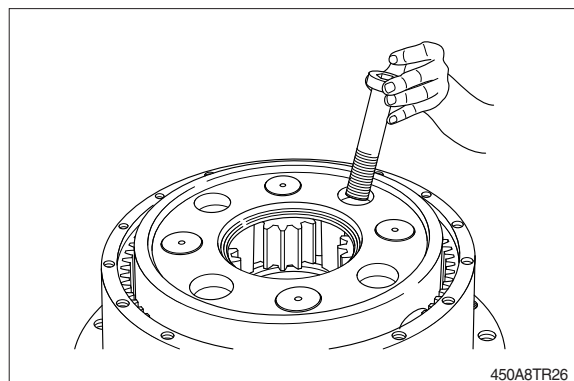

(24) Using a press and a metal stopper, remove the flanged hub (17) from the gearbox housing (14), paying attention to the eventual falling down of the main bearing's balls.

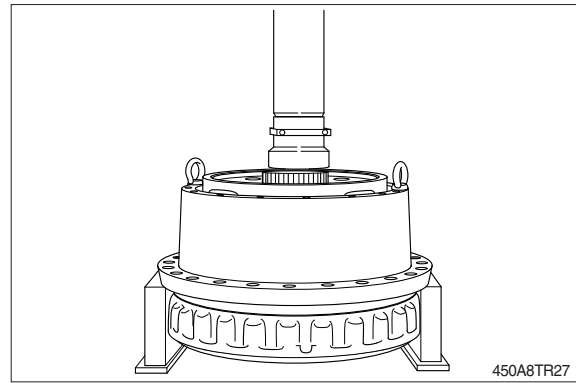

(25) Remove the 3rd reduction assembly (12) from the flanged hub (17).

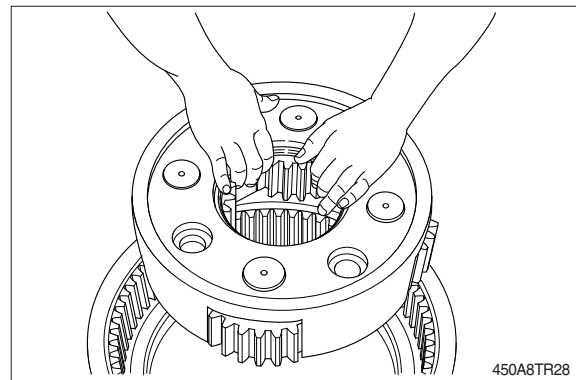

(26) Using the equipment, remove bushes (13) from the flanged hub (17).

- ※ It is possible that the planet assemblies (see reassembly (11)) remain assembled to the planet-carrier. In this case it is sufficient to push on them by means of a rubber pad or a press.
- In case the planet assemblies remain assembled to the flanged hub, it is better to use the fixture (for this operation).

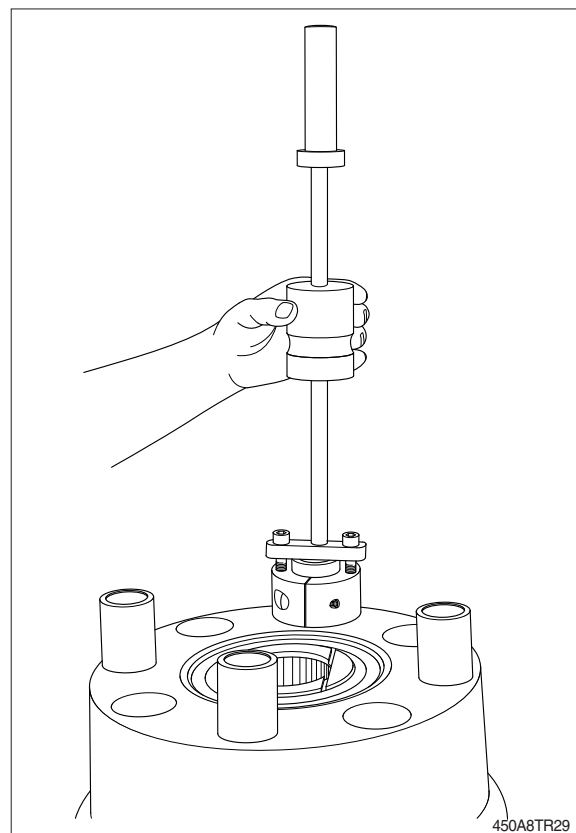

(27) By means of an extractor, remove the inner race of the bearing and spacer kept on the flanged hub (17).

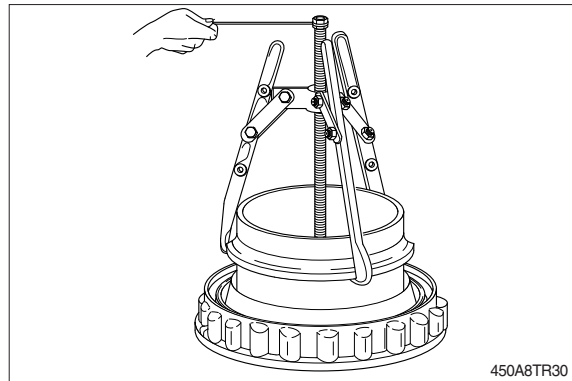

(28) Withdraw both the half-seals (16) from the flanged hub (17) and from the gearbox housing (15).

※ Lifetime seal check

In case of oil leakages, it should be necessary to check and eventually replace the lifetime seal (16), which means both the metal rings parts and the O-rings. In this case it is necessary to disassemble the gearbox from the machine.

※ The gearbox disassembly ends with the above operation: All items are now available for the necessary checks.

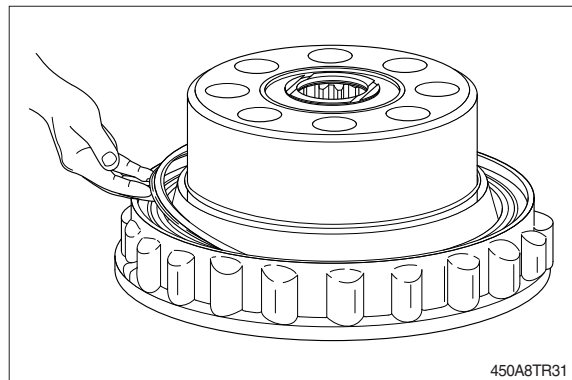

3) REASSEMBLY

※ For the correct assemble of gearbox please follow these basic instructions:

In case of damaged gears, for example a planetary, replace all the reduction assembly and not only the damaged gear.

※ Before reassembling the O-ring, gaskets and the oil seals:

Concerned should be removed.

Clean with care all the housing of the seal and put some grease on the gasket before mounting.

※ Never change only one part of the lifetime seal, always the two rings together.

(1) Fit the half seals (16) on the tool.

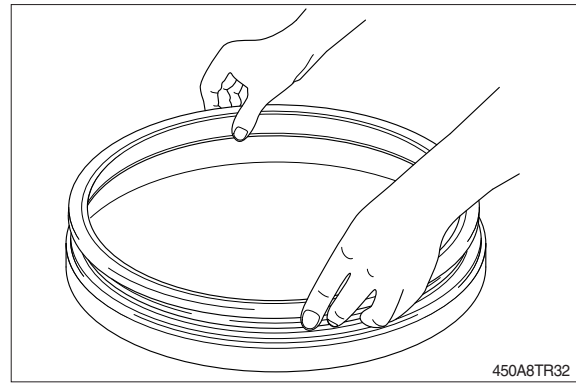

(2) Fit the half seals (16) inside the gearbox housing (15).

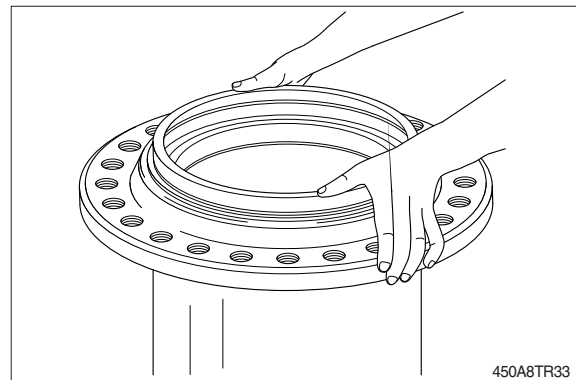

(3) Clean carefully the metallic face of the half-seal.

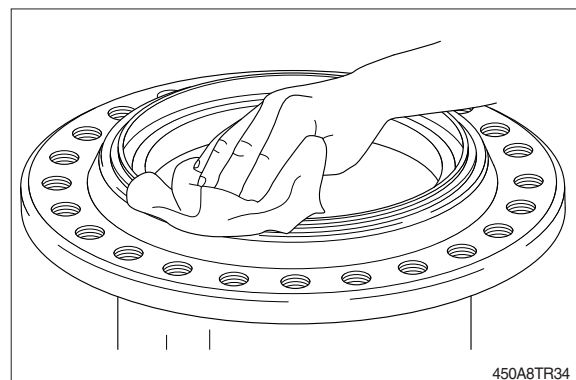

(4) Assemble, by using the same tool, the half seal (16) on the flanged hub (17).

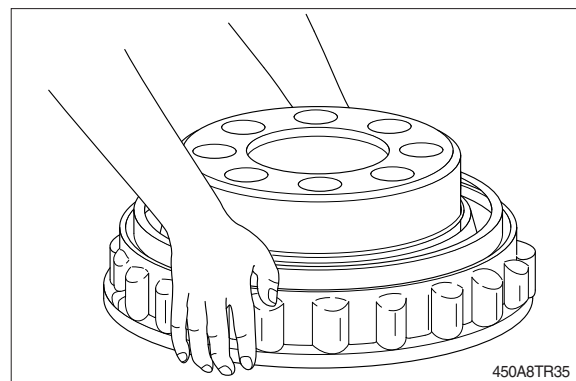

- (5) Lube the metallic face of the half seal with a thin oil film.

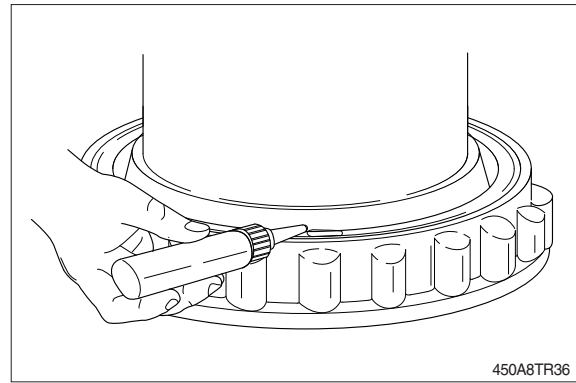

- (6) Fit on the housing the lower ball row, withstanding the ball race through the spacers 1 and 2.
Between the balls, insert the proper spacers.

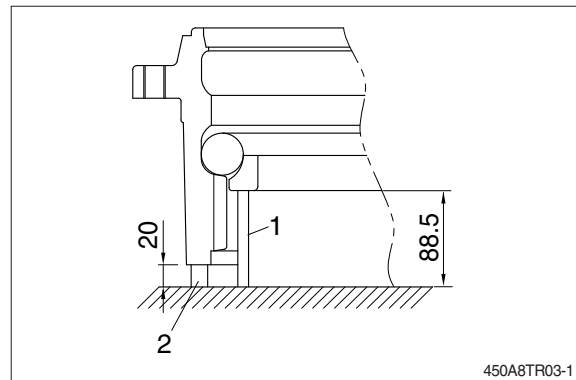

- (7) After having placed the bearing spacer fit the upper ball row.
Then place the upper inner race.

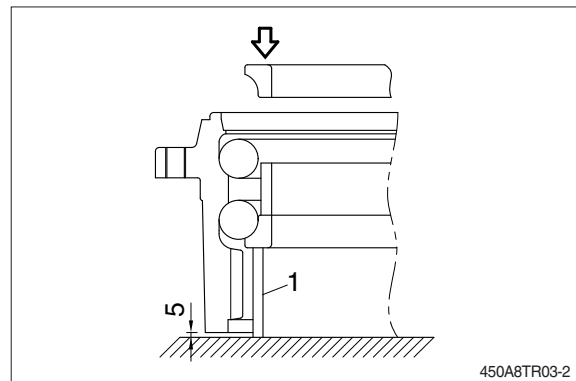

- (8) Lift the flanged hub (17) then lower it inside the gearbox housing (15).

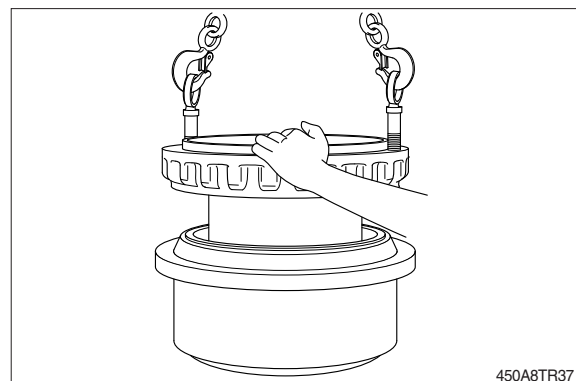

(9) Using a press and a metal stopper, push the flanged hub (17) against the shoulder on the gearbox housing (15) until assembling is complete.

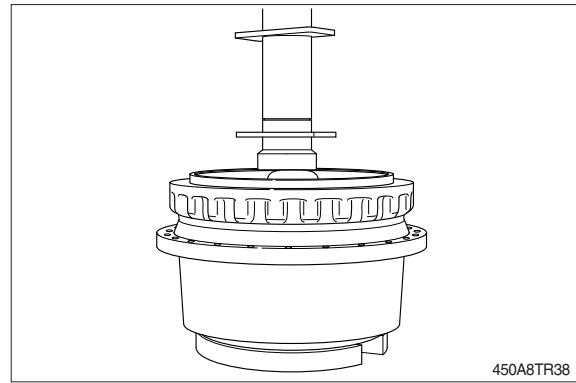

(10) Using a press, place and push the 4 bush, inside their seats on the flanged hub (17).

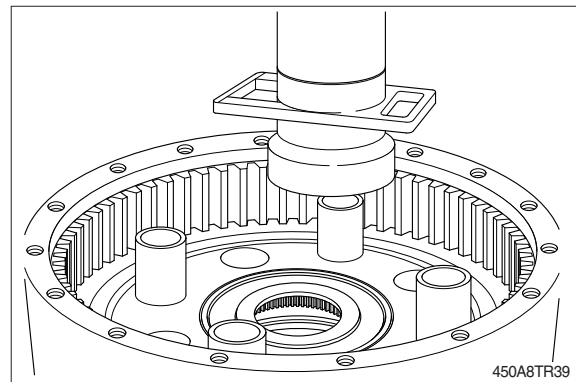

(11) View of the 3rd reduction's planet assembly.

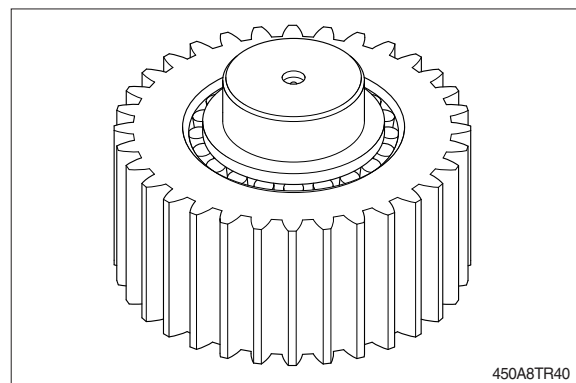

(12) Using a press push the 4 planet assemblies against the shoulder on the flanged hub (17).

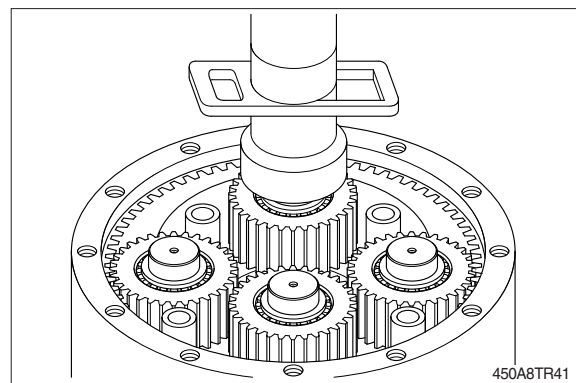

(13) Place the 3rd reduction planet carrier on the hub (17).

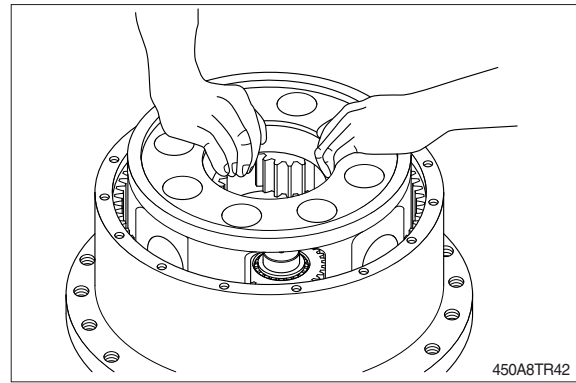

(14) Using a press push the 3rd reduction planet carrier against the shoulder on the flanged hub (17) until complete assembly.

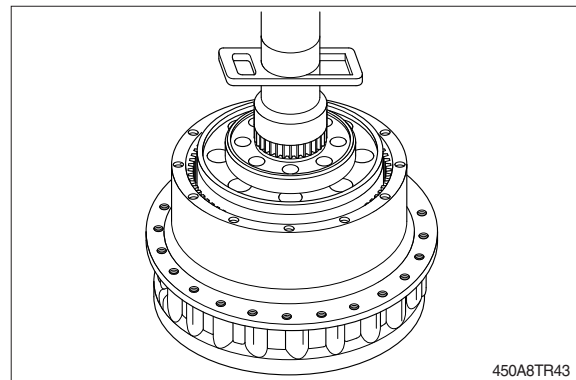

(15) Apply LOCTITE type 243 on the 4 socket head screws (11), and insert them in the thread holes.

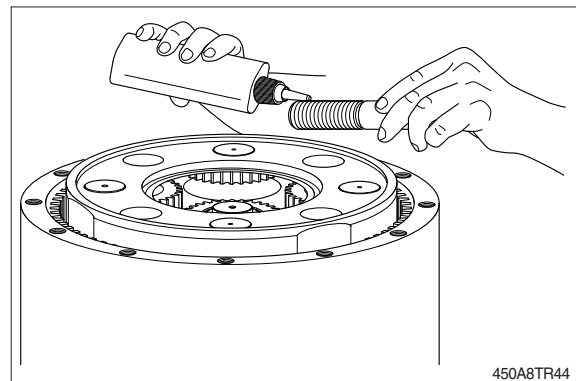

(16) Tighten the screws by a torque wrench at a torque of $153\text{kgf} \cdot \text{m}$ ($1107\text{lb} \cdot \text{ft}$), locking the gearbox acting with the press on a 3rd reduction's planet.

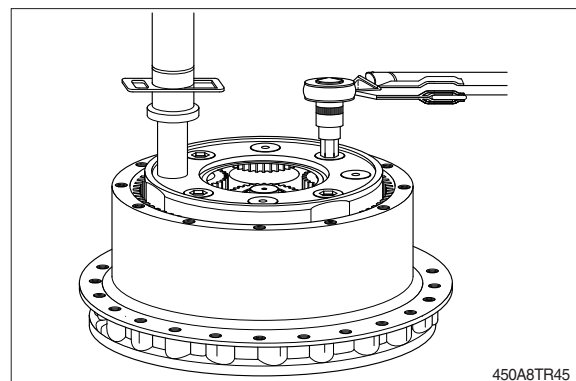

(17) Insert the 3rd stage sun gear (14).

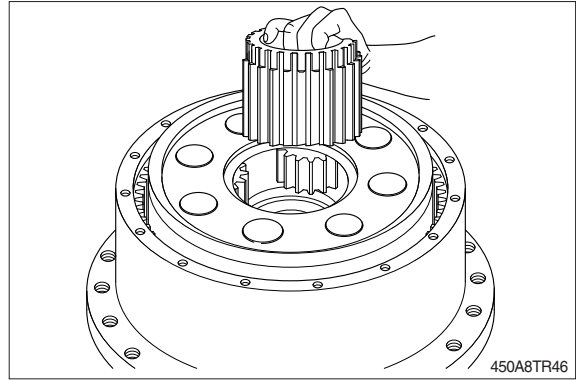

(18) Insert the 2nd reduction assembly (10).

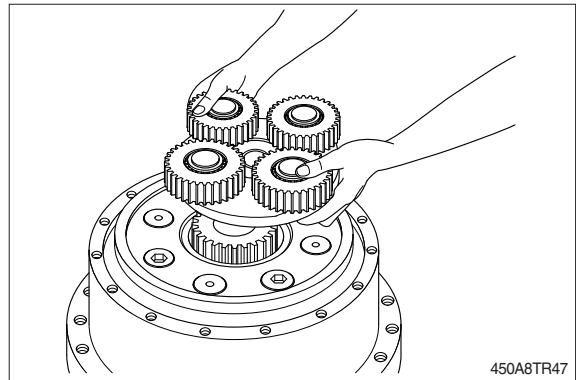

(19) Insert the 2nd stage sun gear (9).

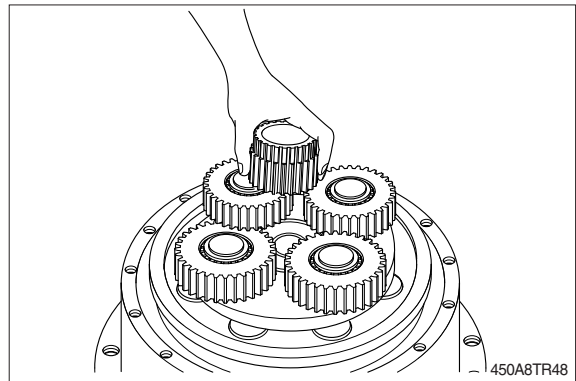

(20) Insert the 1st reduction assembly (8).

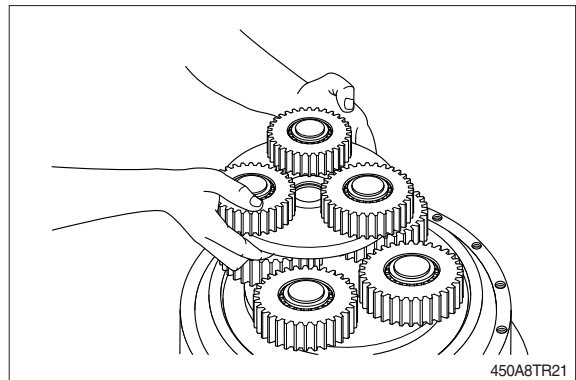

(21) Insert the 1st stage sun gear (7).

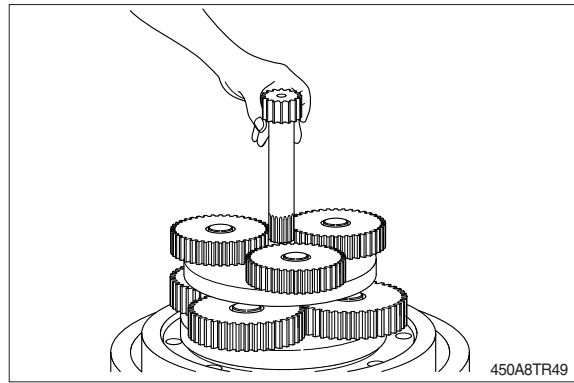

(22) Fit the O-ring (5) into its groove in the end cover (4).

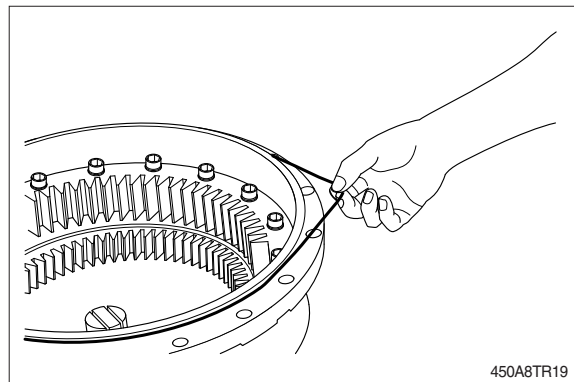

(23) Place the end cover (4) on the gearbox housing (15).

Apply LOCTITE type 243 on the 16 socket head screws (3), and tighten them by a torque wrench at a torque of 19.4 kgf · m (140 lbf · ft).

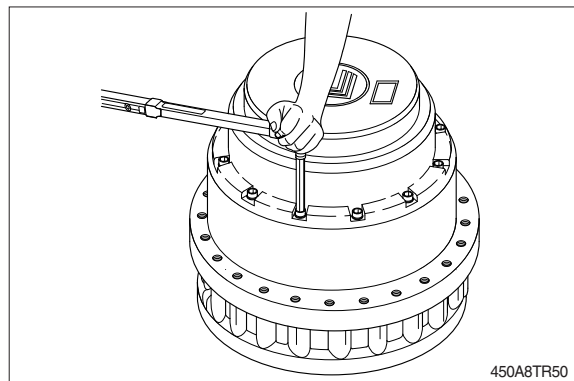

(24) Place the 2 washer (1) in their groves and tighten the 2 plugs at a torque of 6.1~8.2 kgf · m (44.1~59.3 lbf · ft).

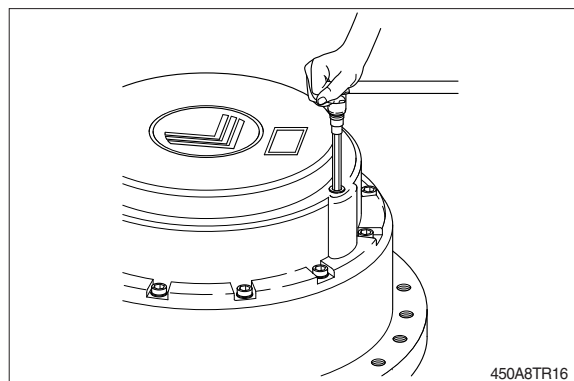

(25) Turn the gearbox around and insert the brake shaft (19).

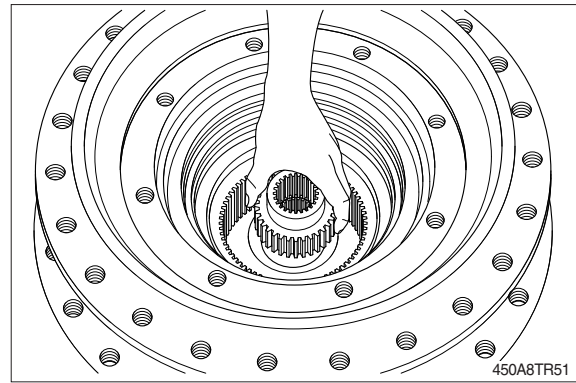

(26) View of the brake discs (21, 22).

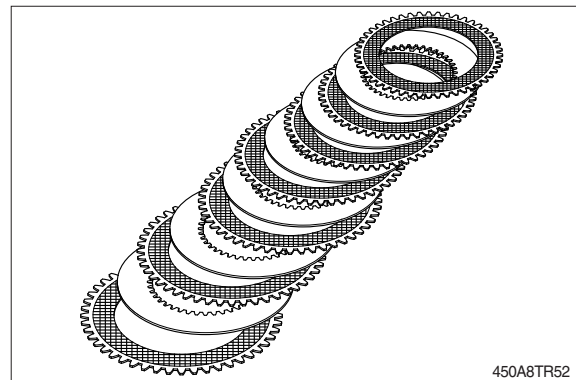

(27) Assemble the brake discs package according to the following order: Firstly insert an external toothed sintered bronze disc (21). Then insert, an internal toothed steel disc (22). Repete the operation until reaching the number of 7 bronze and 6 steel discs.

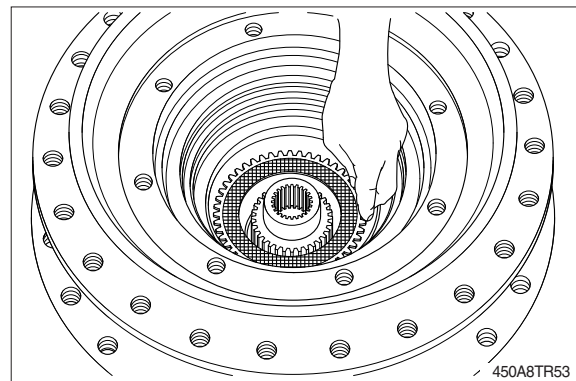

(28) Fit the backup rings (23, 26) and the O-rings (24, 25) inside the two internal grooves of the flanged hub (17, see drawing).

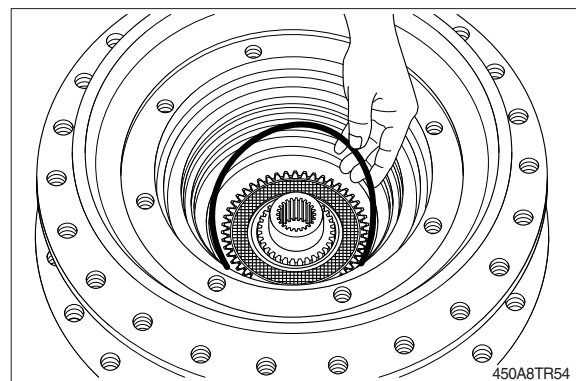

- ※ An O-ring and a backup ring must be fitted in the groove paying attention that the backup ring must always be beyond the O-ring against the oil flow.

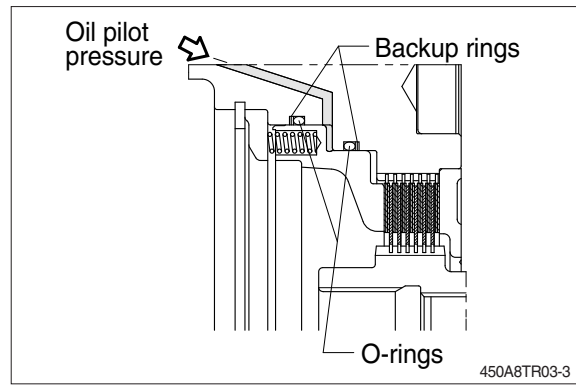

- (29) Insert the brake piston (27) inside the flanged hub (17), paying attention not to damage the seals already fitted.

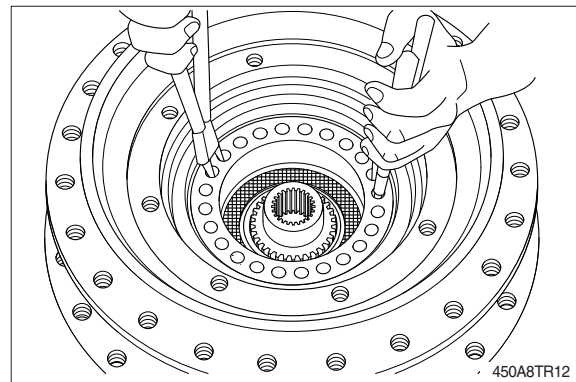

- (30) Insert the springs (28) into the grooves in the brake piston (27).

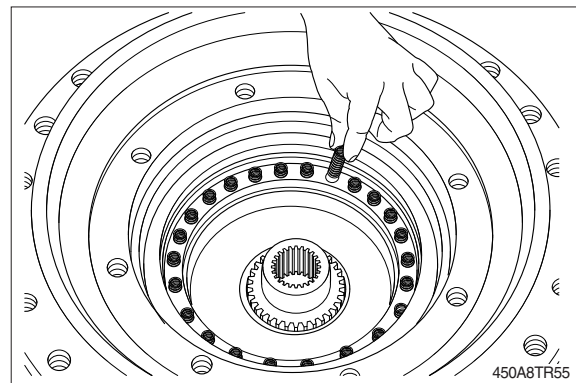

- (31) Insert the retainer disc (29).

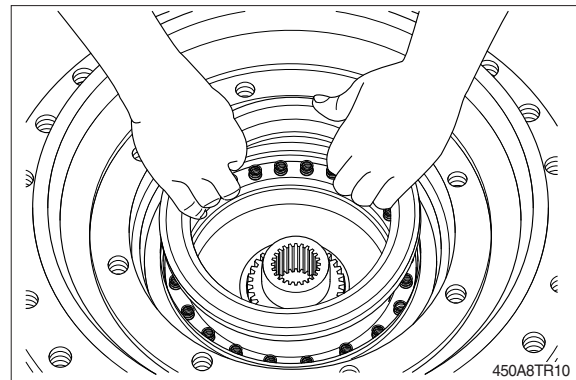

(32) Fixed the equipment to the flanged hub (17) and screw the threaded screw up the springs retainer disc (29) is lowered below the circlip seat (30).

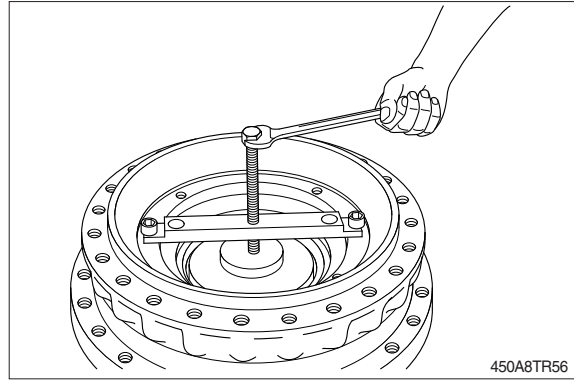

(33) By means of pliers, place the circlip (30) into its groove.

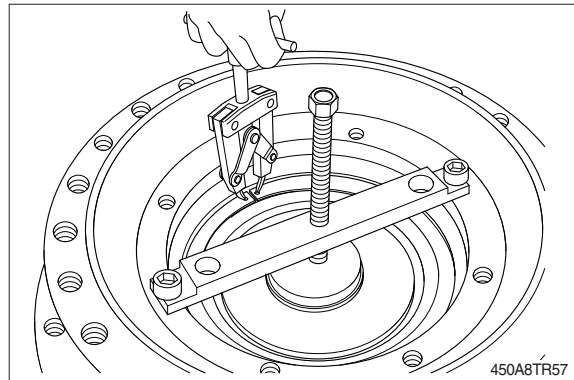

(34) Fit the O-ring (36) into its groove in the flanged hub (17).

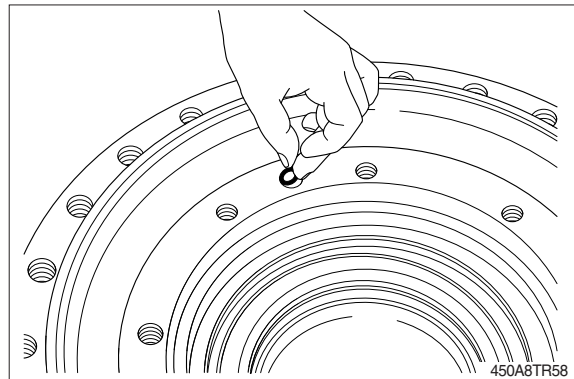

(35) Fit the O-ring (20) into the groove of the motor flange (32).

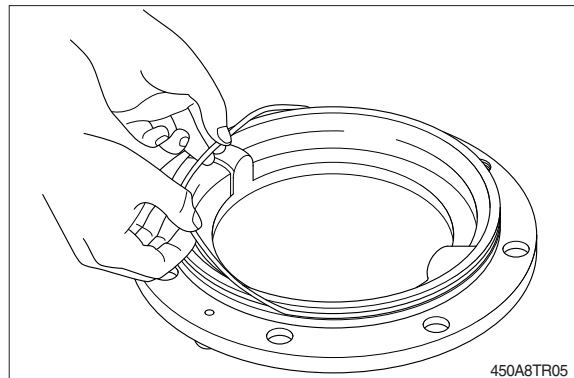

(36) Place and fix the motor flange (32) to the flanged hub (17) through 8 screws (35) tightened by a torque wrench at a torque of $21.9 \text{ kgf} \cdot \text{m}$ ($158.4 \text{ lbf} \cdot \text{ft}$).

※ After having reassembled the gearbox, fit the travel motor (taking care to include the O-ring(32), by means of 2 fixing screws(33), tightened at $42.3 \text{ kgf} \cdot \text{m}$ ($306.0 \text{ lbf} \cdot \text{ft}$). Fill the gearbox with the lubricant oil.

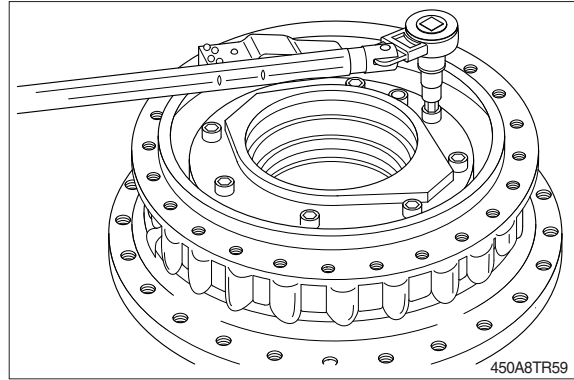

TRAVEL DEVICE (TYPE 4)

1. REMOVAL AND INSTALL

1) REMOVAL

- (1) Swing the work equipment 90 ° and lower it completely to the ground.
- (2) Operate the control levers and pedals several times to release the remaining pressure in the hydraulic piping.
- (3) Loosen the breather slowly to release the pressure inside the hydraulic tank.

▲ Escaping fluid under pressure can penetrate the skin causing serious injury.

※ When pipes and hoses are disconnected, the oil inside the piping will flow out, so catch it in oil pan.

- (4) Remove the track shoe assembly.
For details, see removal of track shoe assembly.
- (5) Remove the cover.
- (6) Remove the hoses.
※ Fit blind plugs to the disconnected hoses.
- (7) Remove the bolts and the sprocket.
- (8) Sling travel device assembly (1).
- (9) Remove the mounting bolts (2), then remove the travel device assembly.
 - Weight : 632 kg (1393 lb)
 - Tightening torque : 57.9 ± 8.7 kgf · m
(419 ± 62.9 lbf · ft)

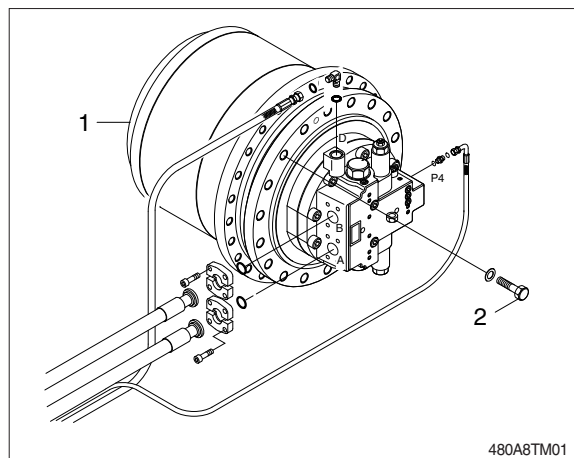

2) INSTALL

- (1) Carry out installation in the reverse order to removal.
- (2) Bleed the air from the travel motor.
 - ① Remove the air vent plug.
 - ② Pour in hydraulic oil until it overflows from the port.
 - ③ Tighten plug lightly.
 - ④ Start the engine, run at low idling, and check oil come out from plug.
 - ⑤ Tighten plug fully.
- (3) Confirm the hydraulic oil level and check the hydraulic oil leak or not.

2. TRAVEL MOTOR

1) STRUCTURE (1/2)

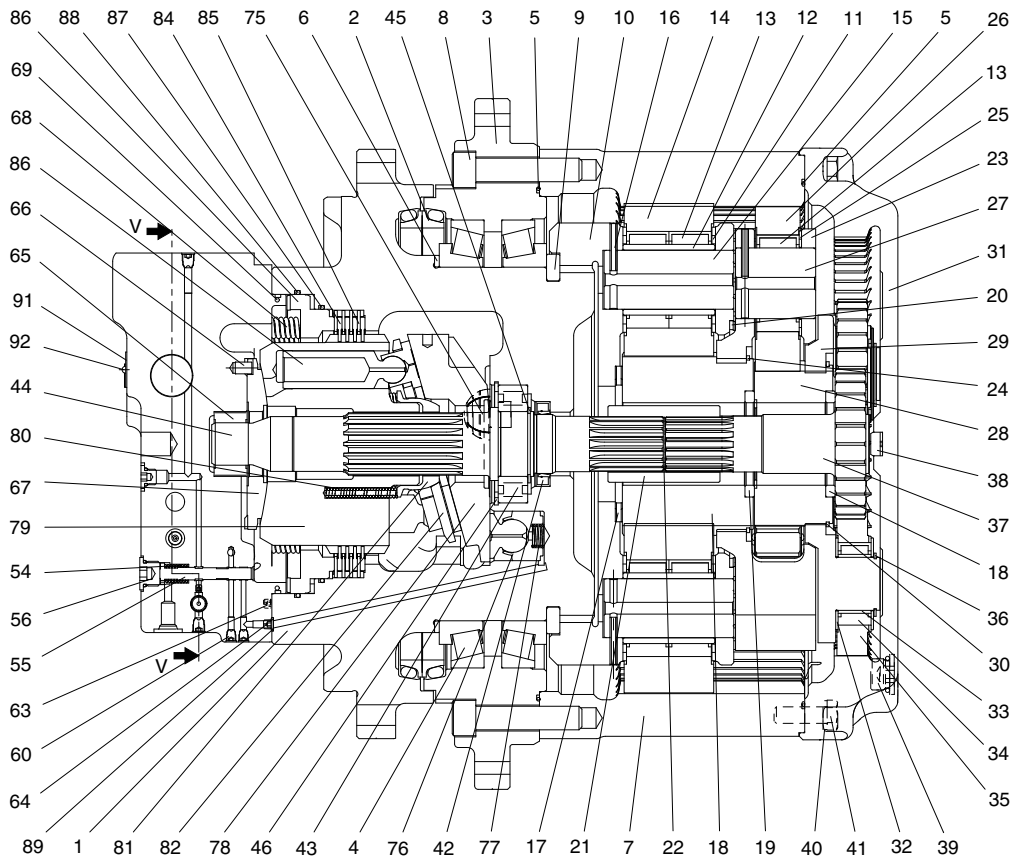

480A2TM02

1	Casing	26	Planetary gear no.2	63	Orifice
2	Floating seal	27	Shaft no.2	64	Orifice
3	Hub	28	Sun gear no.2	65	Needle bearing
4	Taper roller bearing	29	Carrier no.1	66	Parallel pin
5	O-ring	30	Clip	67	Valve plate
6	Distance piece	31	Cover	68	Spring
7	Ring gear	32	Side plate	69	O-ring
8	Socket bolt	33	Ring inner	75	Pivot
9	Shim plate	34	Needle bearing	76	2 speed piston assy
10	Carrier no.3	35	Planetary gear no.1	77	2 speed piston spring
11	Thrust washer	36	Snap ring	78	Swash plate
12	Floating bushing	37	Drive gear	79	Cylinder block
13	Needle bearing	38	Thrust washer	80	Cylinder block spring
14	Planetary gear no.3	39	HS plug assy	81	Spherical bushing
15	Shaft no.3	40	Spring washer	82	Retainer plate
16	Spring pin	41	Hex bolt	83	Piston assy
17	Thrust plate	42	Shaft seal	84	Friction plate
18	Sun gear no.3	43	Roller bearing	85	Separation plate
19	Thrust ring	44	Drive shaft	86	Brake piston
20	Thrust ring	45	Snap ring	87	O-ring
21	Coupling	46	Snap ring	88	O-ring
22	Snap ring	54	2 speed spring	89	O-ring
23	Carrier no.2	55	2 speed spool	91	Name plate
24	Clip	56	HS plug assy	92	Rivet screw
25	Thrust washer	60	MW 08		

STRUCTURE (2/2)

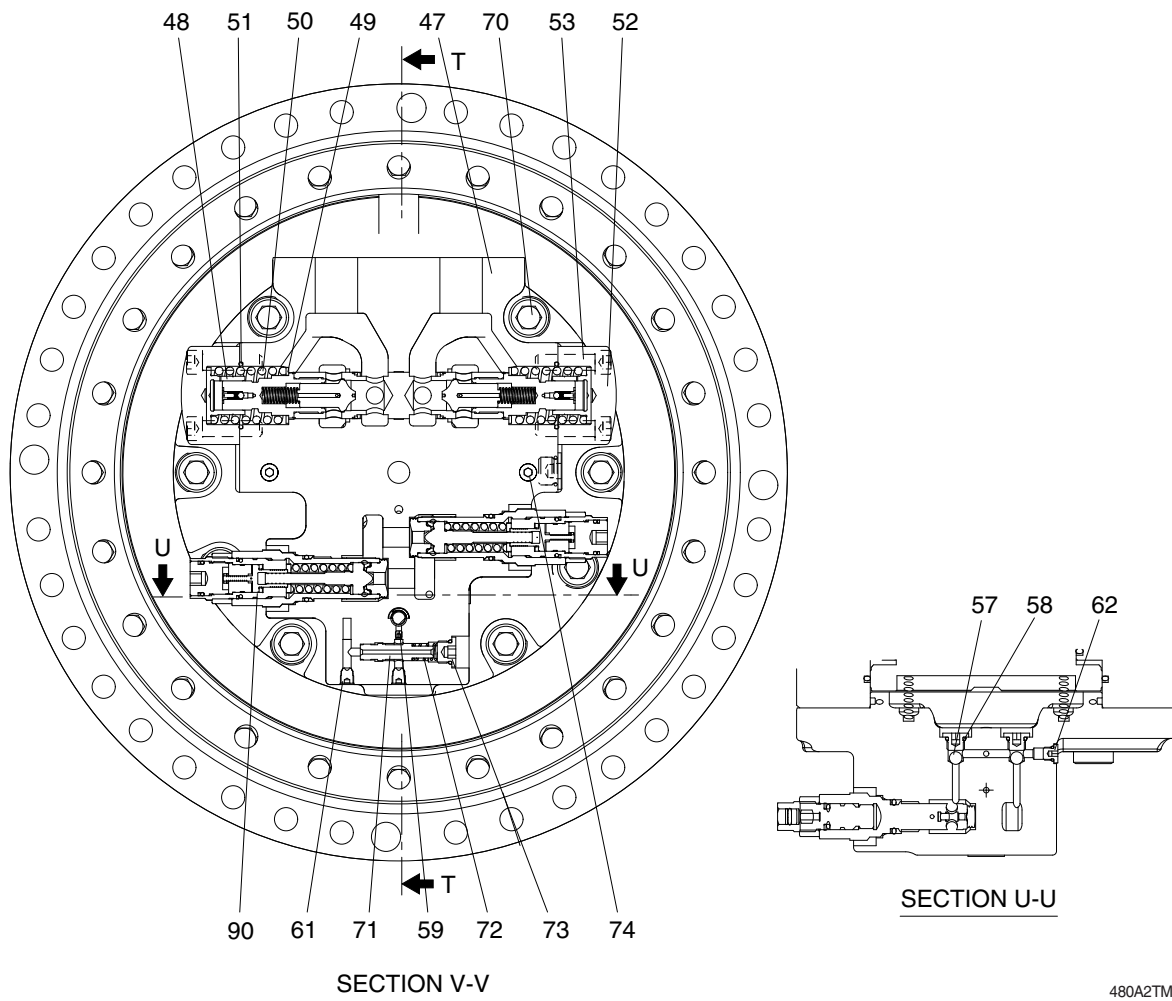

480A2TM03

47	Valve casing	53	Socket bolt	70	Socket bolt
48	Counterbalance spool sssy	57	Steel ball	71	Reducing valve
49	CB Washer	58	HS plug assy	72	Reducing spring
50	CB main spring	59	Orifice	73	HS plug assy
51	O-ring	61	MW 10	74	PT plug
52	CB cover	62	HS plug assy	90	Relief valve

2) TOOLS AND TIGHTENING TORQUE

(1) Tools

Tool name	Remark
Hex bit	8, 10, 17mm
Hex socket	22, 41mm
Eye bolt	M16x2
Guide pin	M20x2.5x45
Torque wrench	Capable of tightening with the specified torques.
Ball bearing assembly press-fit jig	-
Floating seal assembly jig	-
Caliper	-
Plastic hammer	-
Air gun	-
Compressed air	-

(2) Tightening torque

Item	Part name	Torque	
		kgf · m	lbf · ft
39	Plug	17.0 ± 3.0	123 ± 21.7
41	Socket bolt	10.4 ± 1.6	75.2 ± 11.6
53	Socket bolt	17.4 ± 2.5	126 ± 18.1
56	Plug	10.0 ± 2.0	72.3 ± 14.5
58	Plug	6.0 ± 1.5	43.4 ± 10.8
70	Socket bolt	50.3 ± 8.0	364 ± 57.9
90	Relief valve	18.0 ± 3.6	130 ± 26.0

4. DISASSEMBLY AND ASSEMBLY

1) PRECAUTIONS

- (1) Be careful not to damage the seal contact surface of the floating seal, O-ring, shaft seal, etc. and the contact surface of the gear, pin, bearing.
- (2) When disassembling after mounted on the equipment, make sure no foreign substances enter the equipment.
- (3) Clean each part with oil sufficiently and dry it with the compressed air before assembly.
- (4) When using oil absorbent or oil mop, be careful not to scratch the parts. Clean it thoroughly with lint-free cloths before assembly.
- (5) When tightening the bolt and plug, use a torque wrench and tighten the bolt and plug to the specified tightening torque.
- (6) Use a plastic hammer to tap the non-functional parts.
- (7) replace the floating seal, O-ring, shaft seal with a new one when disassembly.
- (8) For the assembly of bearing preload/floating seal, please contact Hyundai dealer for the detailed assembly method.

2) DISASSEMBLY

(1) Disassemble the counterbalance plug and bolt.

※ Required tools : torque wrench, hex bit 10 mm.

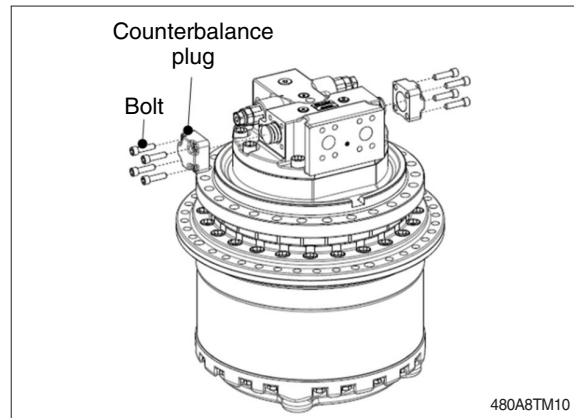

(2) Disassemble the spring, spring seat, O-ring, washer.

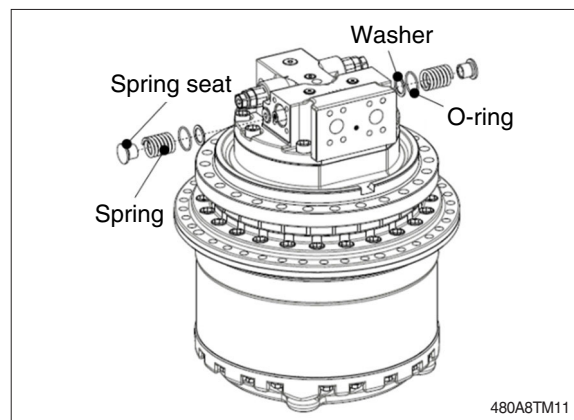

(3) Turn the counterbalance spool assy slowly to disassemble .

※ Damage caution of counterbalance spool surface.

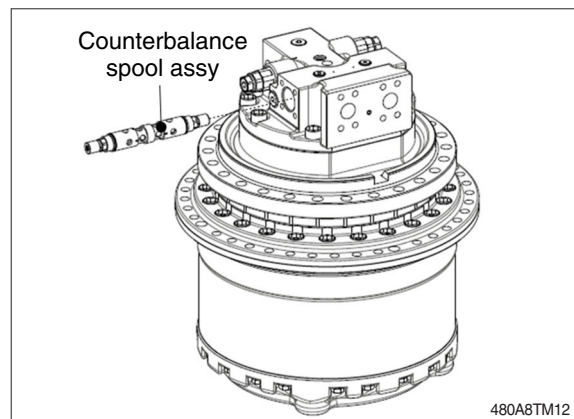

(4) Disassemble the HS plug.

※ Required tools : torque wrench, hex bit 8 mm.

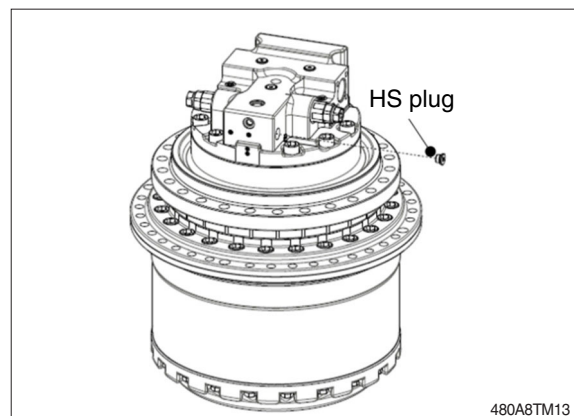

- (5) Disassemble the reducing valve, spring.
※ Damage caution of reducing valve surface.

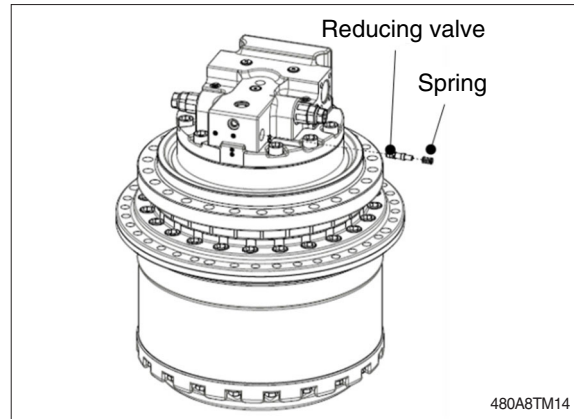

- (6) Disassemble the HS plug.
※ Required tools : torque wrench, hex bit 10 mm.

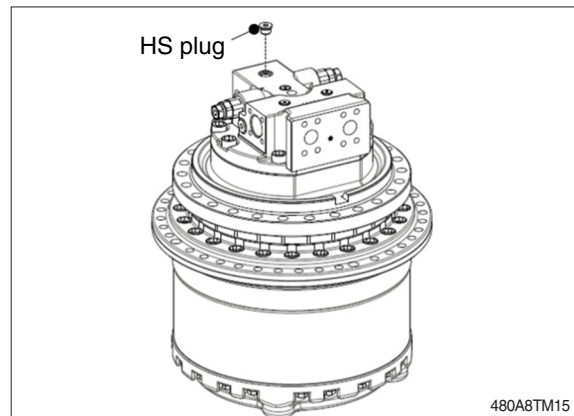

- (7) Disassemble the 2 speed spool and spring.
※ Damage caution of 2 speed spool surface.

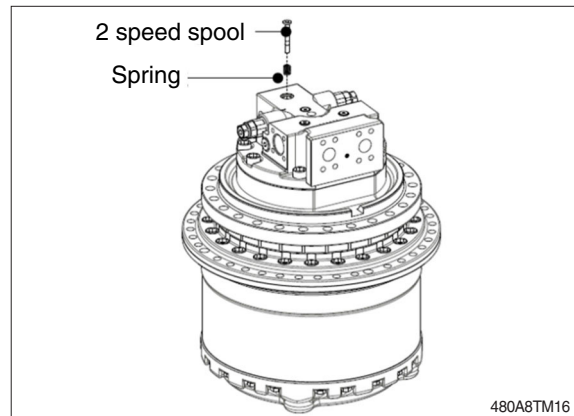

- (8) Disassemble the relief valves.
※ Required tools : torque wrench, hex socket 41 mm.

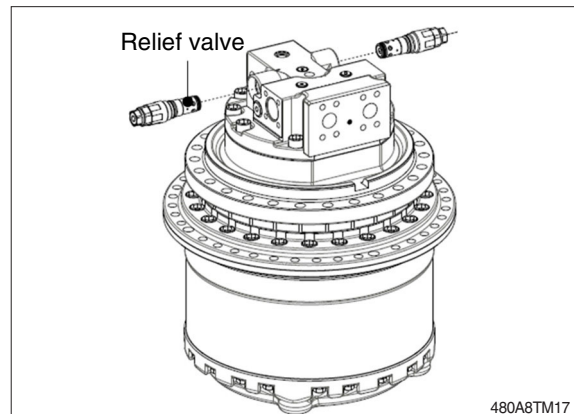

- (9) Loosen each bolt evenly to disassemble.
※ Required tools : torque wrench, hex bit 17 mm.

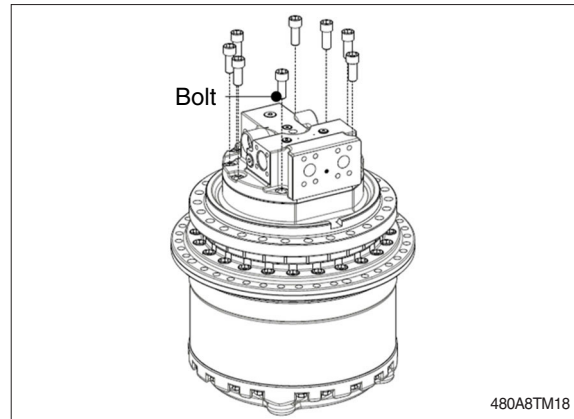

- (10) Disassemble the valve casing.

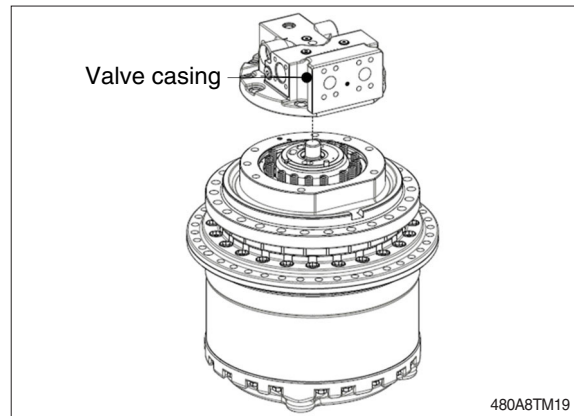

- (11) Disassemble the needle bearing, O-ring, pin.

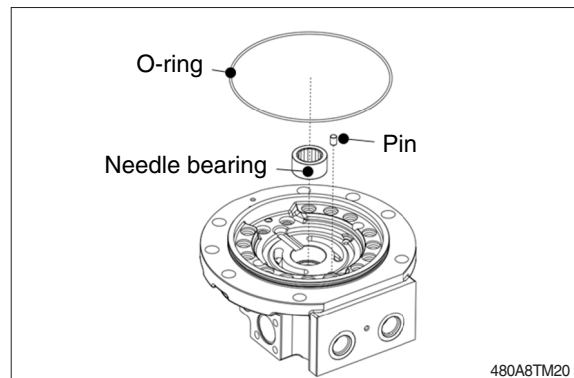

- (12) Disassemble the brake spring.
※ Quantity of the brake springs could be different of each model.
Disassemble the valve plate and O-ring.

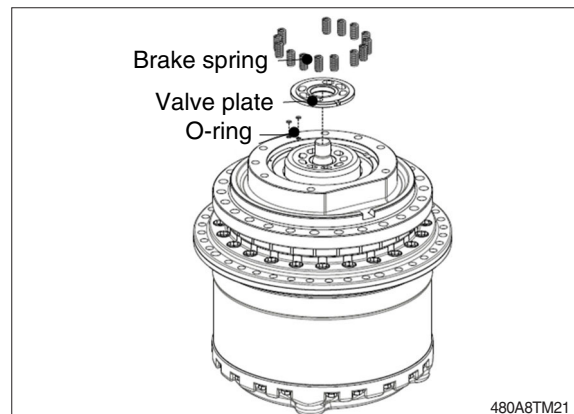

(13) Cover the top of a motor with cloths and disassembly the brake piston by blowing compressed air into the brake releasing line of the motor casing.

Disassemble the O-ring.

※ Required tools : compressed air, air gun.

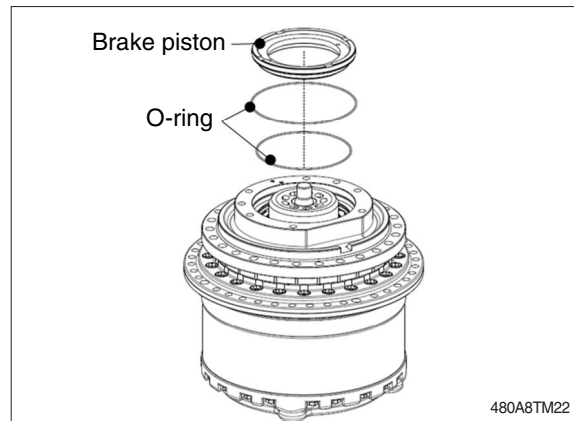

(14) Disassemble separation plate, friction plate, cylinder block assembly, spherical bush, spring, retaining plate and piston assembly.

※ Quantity of separation and friction plates could be different of each model.

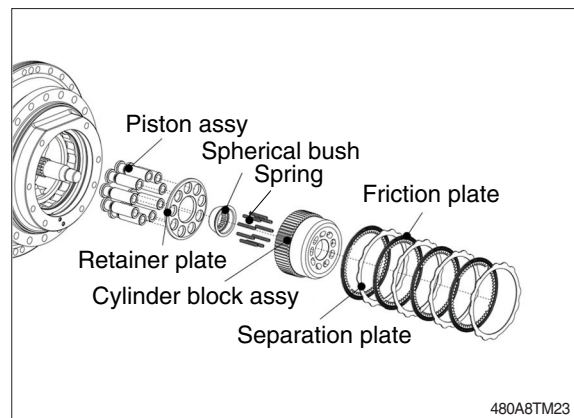

(15) Disassemble the swash plate, pivot, 2 speed piston and spring.

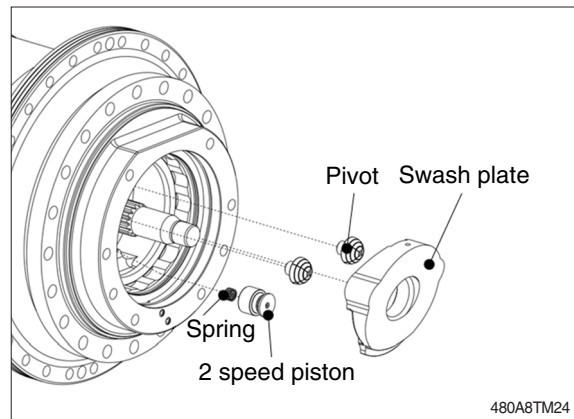

(16) Disassemble the HS plug and discharge the reduction gear oil.

※ Required tools : torque wrench, hex bit 10 mm.

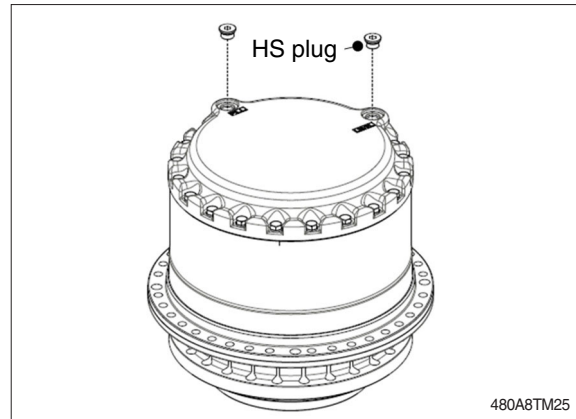

(17) Disassemble the bolt and washer.

※ Do not re-use.

※ Required tools : torque wrench, hex socket 22 mm.

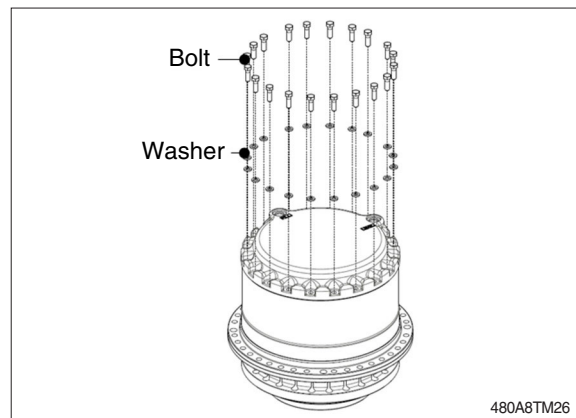

(18) Disassemble the cover, thrust washer and O-ring.

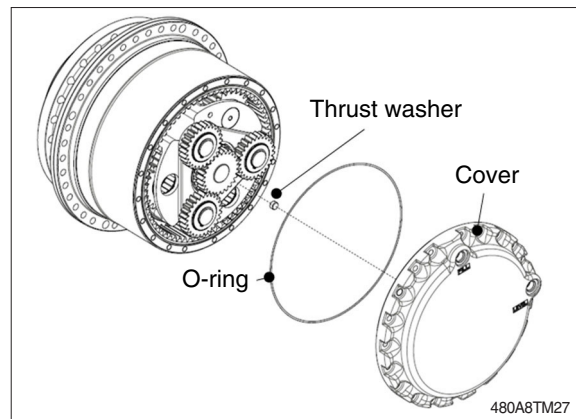

(19) Disassemble the sun gear 1st and thrust plate.

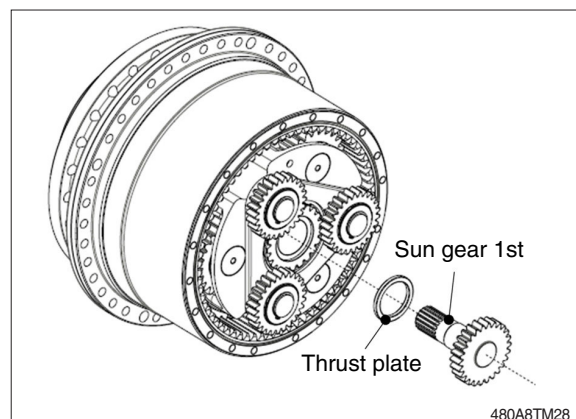

(20) Disassemble the carrier 1st assembly and sun gear 2nd.

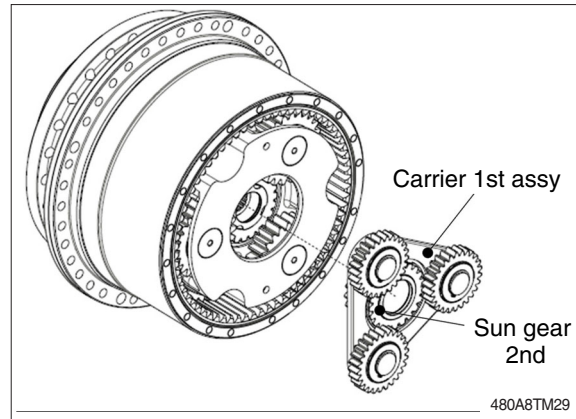

(21) Disassemble the thrust washer.

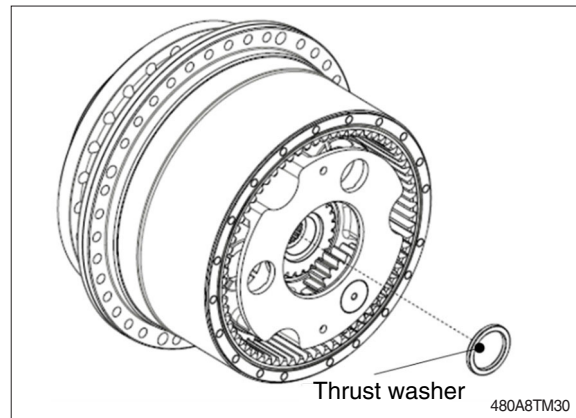

(22) Disassemble the carrier 2nd assembly and sun gear 3rd.

※ Required tools : eye bolt M16x2 (2ea)

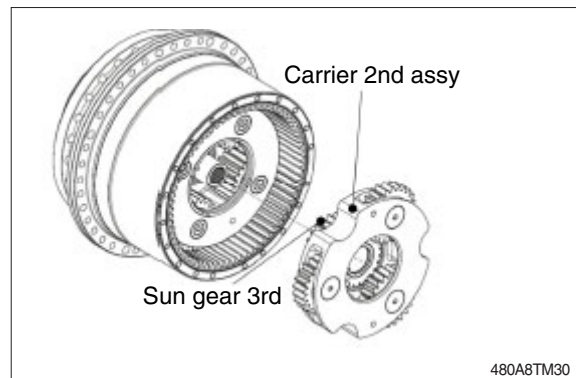

(23) Disassemble the thrust ring, coupling and thrust plate.

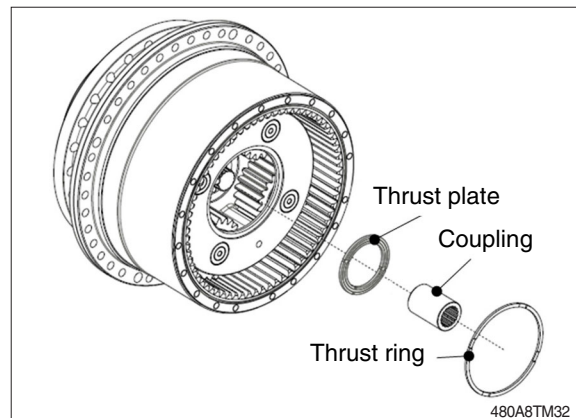

(24) Disassemble the carrier 3rd assembly.

※ Required tools : eye bolt M16x2 (2ea)

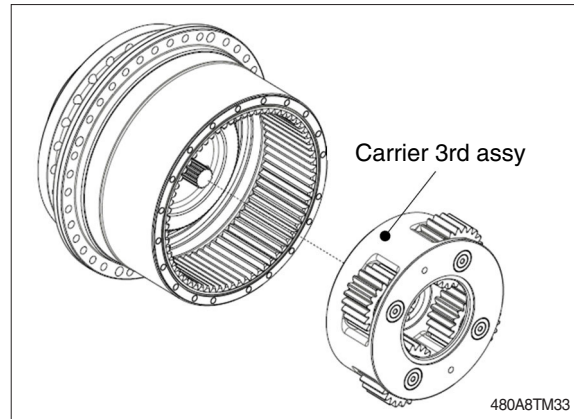

(25) Disassemble the shim plate.

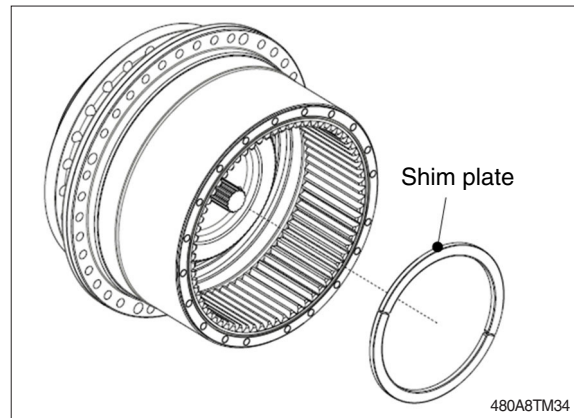

(26) Disassemble the gear casing.

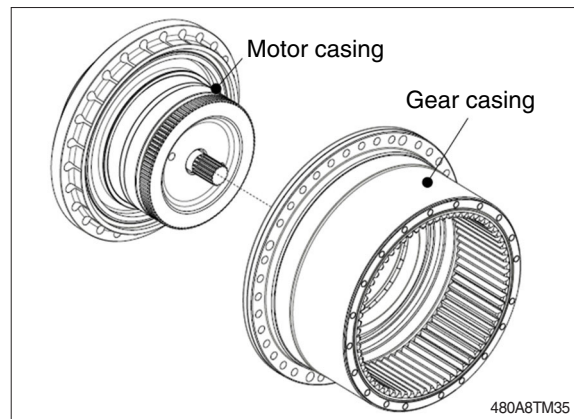

(27) Disassemble the floating seals and O-ring.

※ Damage caution of floating seal.

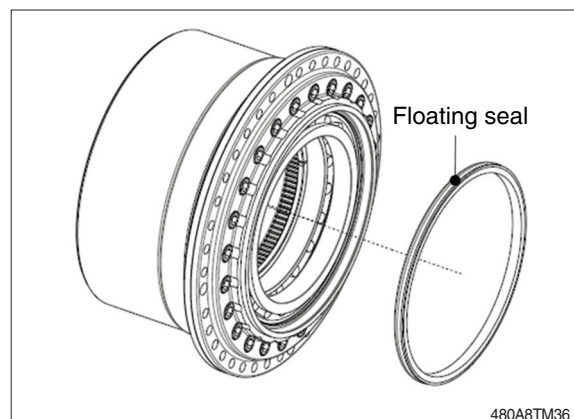

(28) Disassemble the bolt, gear casing, O-ring and ring gear.

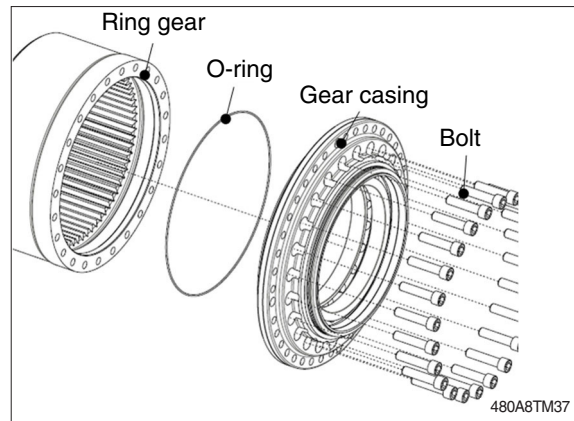

(29) Disassemble the angular ball bearing.
※ Do not disassemble if not necessary.

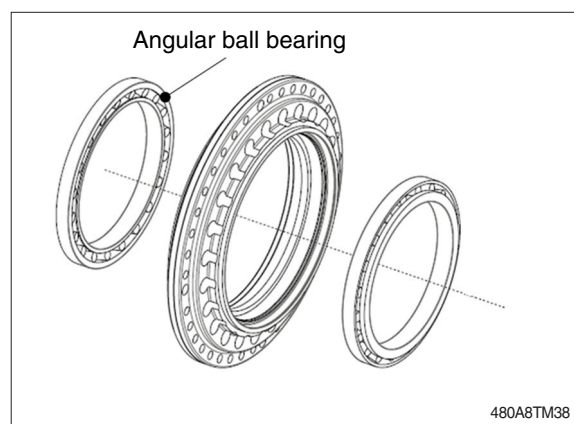

(30) Disassemble the floating seal and shim plate.
※ Damage caution of floating seal.

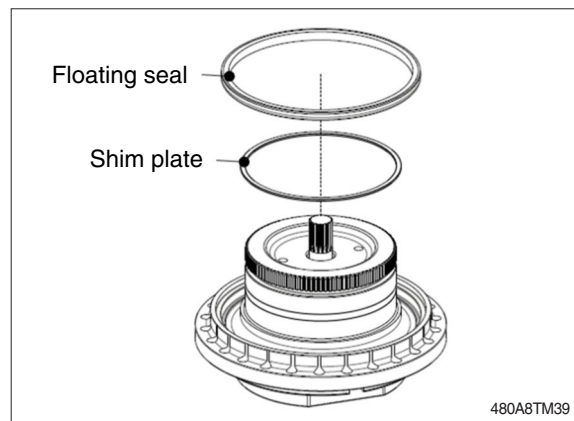

(31) Disassemble the drive shaft and ball bearing and snap ring.
※ Required tools : plier

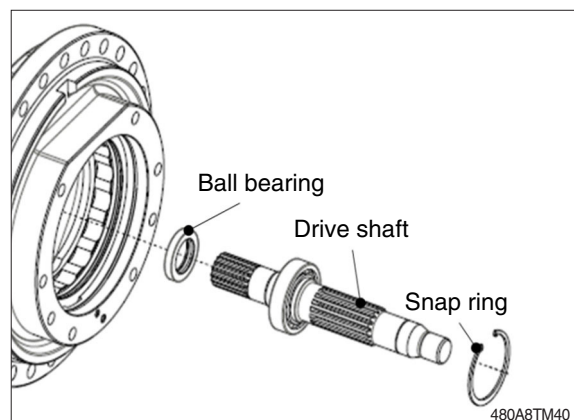

(32) Disassemble the shaft seal.

※ Do not re-use.

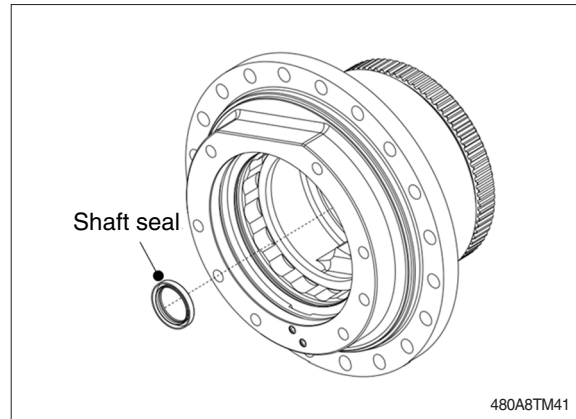

(33) Disassemble the ball bearing and snap ring.

※ Do not disassemble if not necessary.

※ Required tools : plier

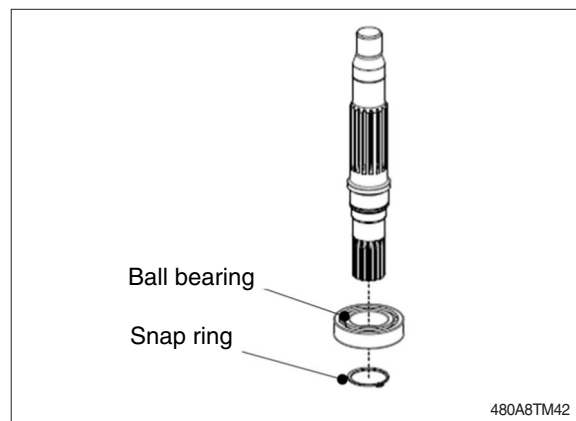

3) ASSEMBLY

- (1) Apply a small amount of hydraulic fluid to the outer diameter of the shaft seal and assemble it to the motor casing

※ Required tools : shaft seal press-fit jig

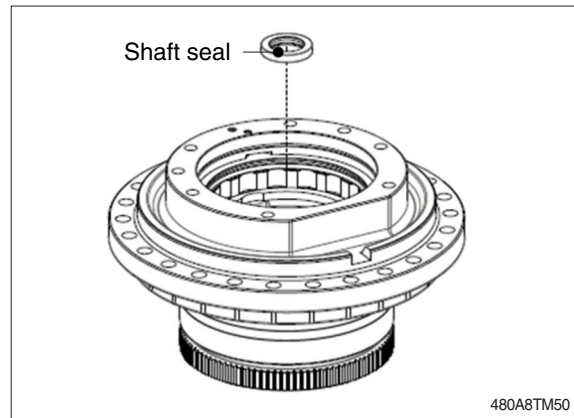

- (2) Assemble the ball bearing and snap ring to the drive shaft.

※ Required tools : ball bearing assembly press-fit jig, plier.

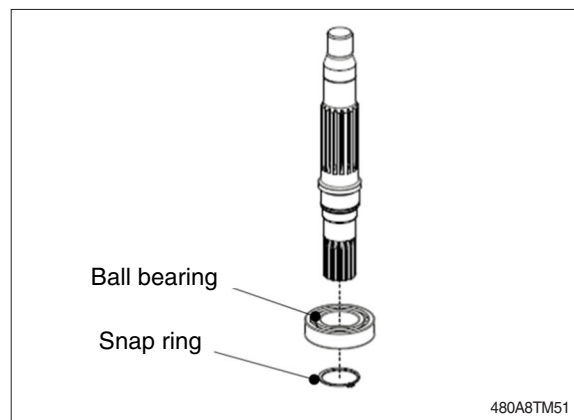

- (3) Assemble the drive shaft, ball bearing and snap ring to the motor casing.

※ Required tools : plier

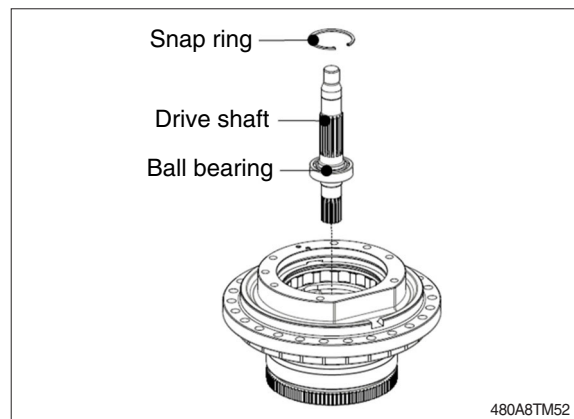

- (4) Apply vaporizing lubricant to the O-ring outside of the floating seal and assemble it to the motor casing so that the parallelism can be 0.5 mm or less. After assembly, apply a small amount of hydraulic fluid to the polishing surface.

※ Required tools : floating seal assembly jig.

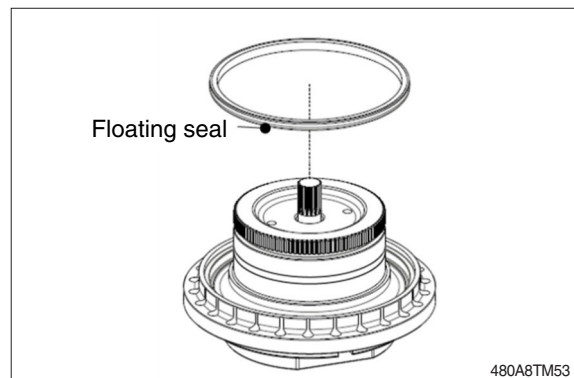

- (5) Assemble the angular ball bearing into the gear casing.
Assemble the O-ring into the gear casing.
※ Required tools : angular ball bearing assembly press-fit jig.

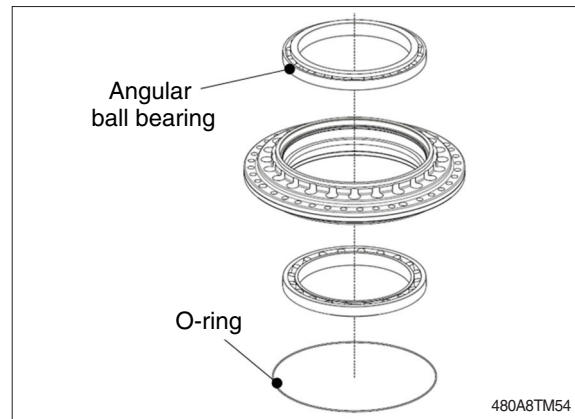

- (6) Assemble the gear casing and ring gear.
Assemble the bolt after applying loctite 638.
※ Required tools : torque wrench, hex bit 17 mm.
※ Bolt size : M20x2.5
※ Tightening torque : 50.3 ± 8.0 kgf · m
(364 ± 57.9 lbf · ft)

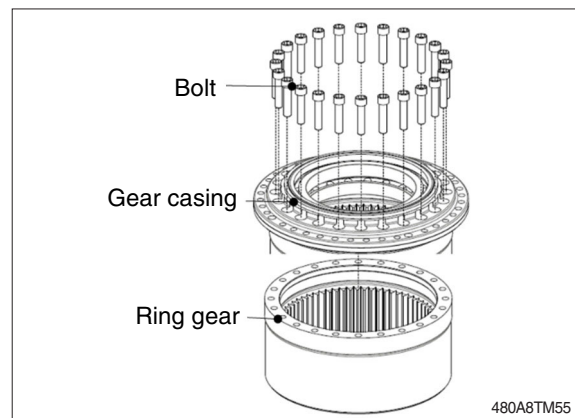

- (7) Apply vaporizing lubricant to the O-ring outside of the floating seal and assemble it to the gear casing so that the parallelism can be 0.5 mm or less. After assembly, apply a small amount of hydraulic fluid to the polishing surface.
※ Required tools : floating seal assembly jig.

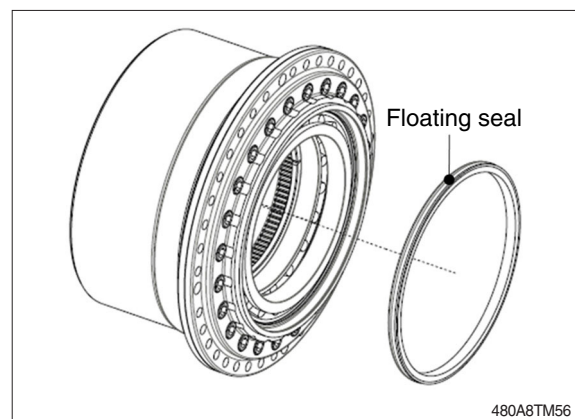

- (8) Assemble the shim plate and gear casing to motor casing.
※ Damage caution of floating seal.

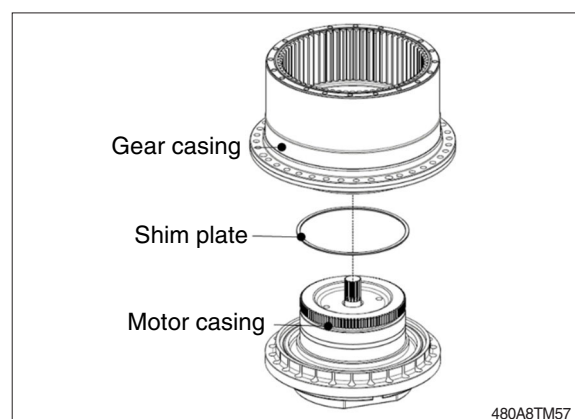

(9) Assemble the shim plate into the motor casing.

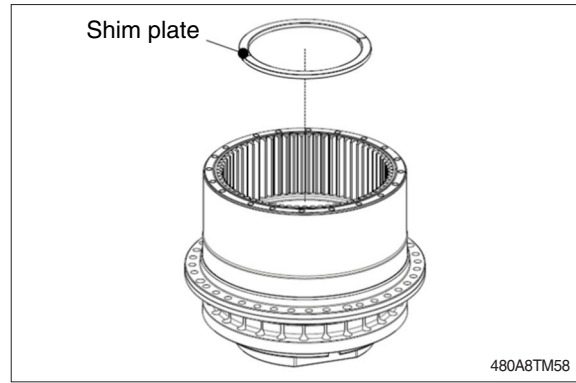

(10) Assemble the carrier 3rd assembly to gear casing.

※ Required tools : eye bolt M16x2 (2ea)

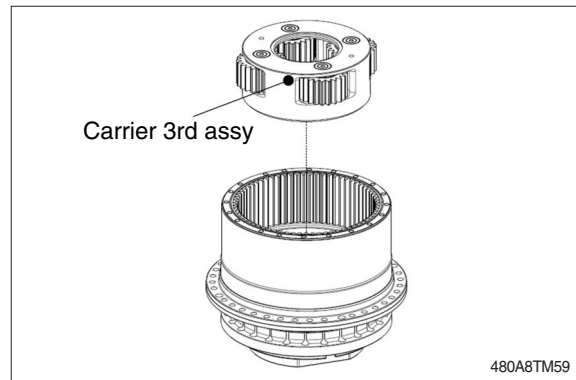

(11) Assemble the coupling and thrust plate.

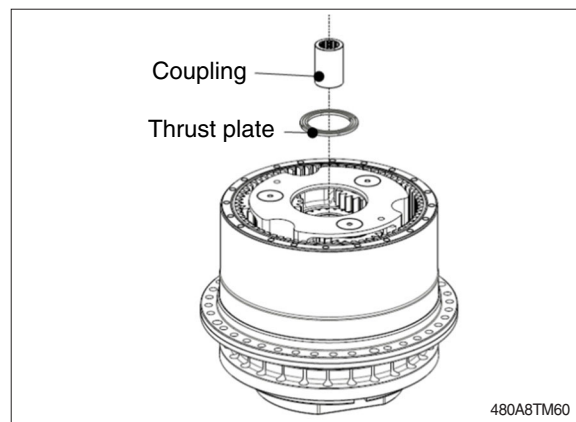

(12) Assemble the carrier 2nd assembly and sun gear 3rd to gear casing.

※ Required tools : eye bolt M16x2 (2ea)

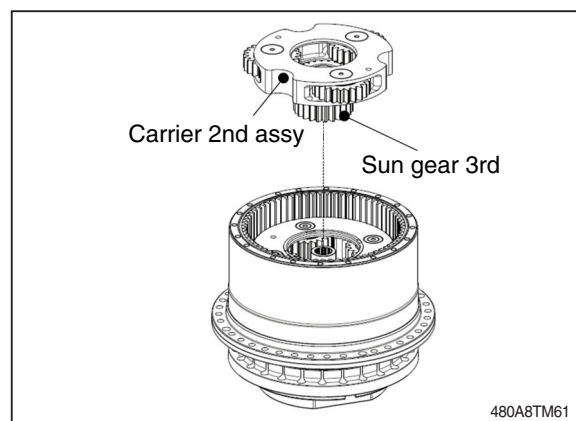

(13) Assemble the thrust plate.

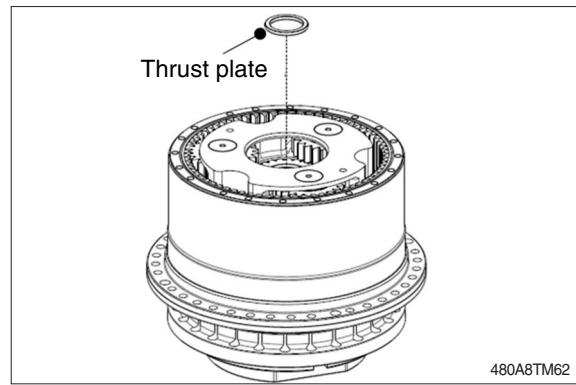

(14) Assemble the carrier no.1 assembly and sun gear 2nd.

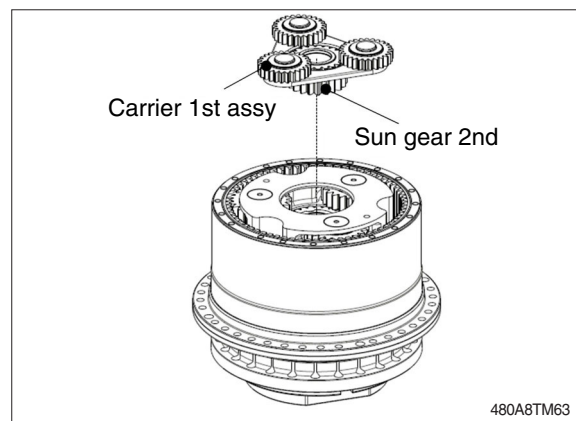

(15) Assemble the thrust plate.

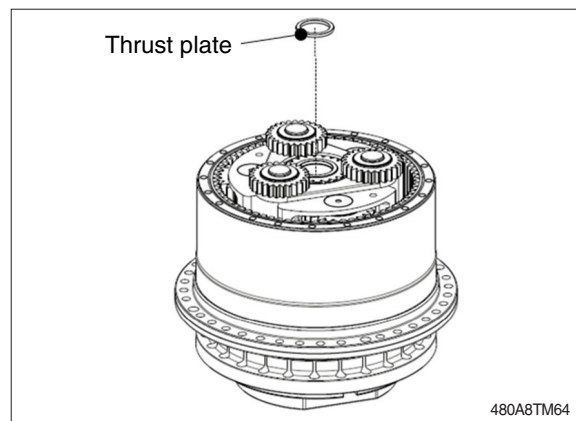

(16) Assemble the sun gear 1st.

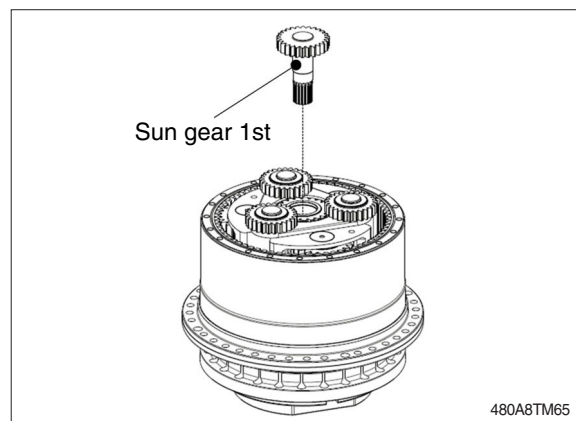

- (17) Apply grease to thrust washer and assemble it to cover.
Assemble the O-ring and cover to gear casing.

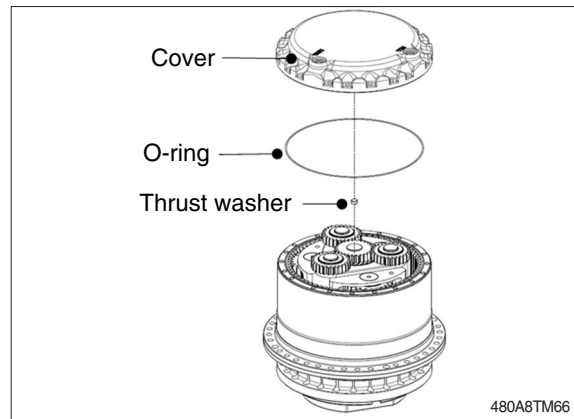

- (18) Assemble the bolt and washer.
- ※ Required tools : torque wrench, hex socket 22 mm.
 - ※ Bolt size : M14x2.0
 - ※ Tightening torque : 17.4 ± 2.5 kgf·m
(126 ± 18.1 lbf·ft)

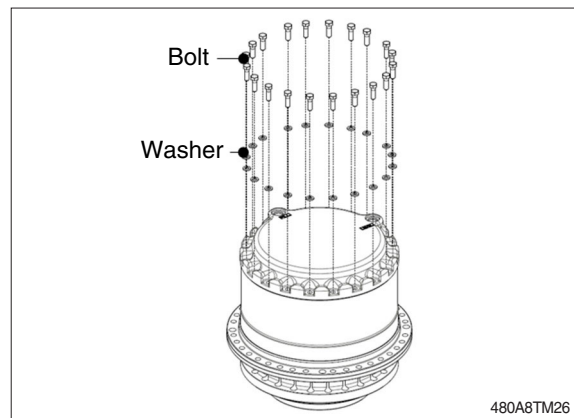

- (19) Fill gear oil of 9 liter minimum and assemble HS plug to cover.
- ※ Required tools : torque wrench, hex bit 10 mm.
 - ※ HH plug size : G 3/4
 - ※ Tightening torque : 17.0 ± 3.0 kgf·m
(123 ± 21.7 lbf·ft)

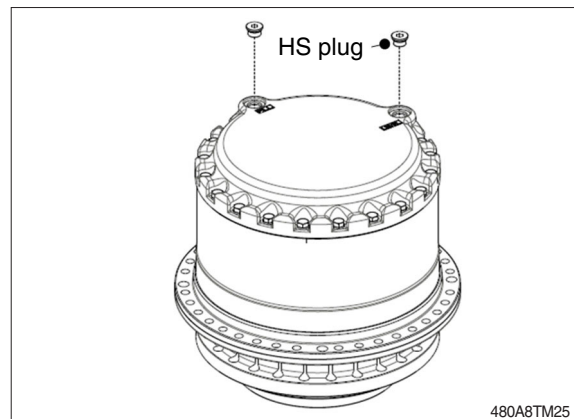

(20) Apply hydraulic fluid to the 2 speed piston outer diameter and swash plate polishing surface.

Apply grease to spring and assemble it to 2 speed piston. Assemble its to the motor casing.

※ Check whether assembled well by pushing 2 speed piston by hand.

Assemble pivot and swash plate to motor casing.

※ Check whether assembled well by pushing 2 speed piston by hand.

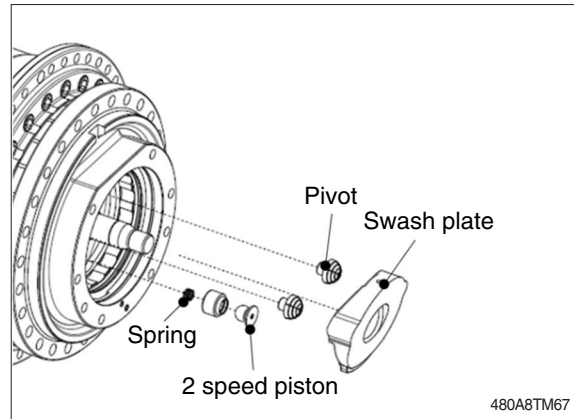

(21) Assemble the cylinder spring, cylinder block, spherical bush, retainer plate and piston assembly.

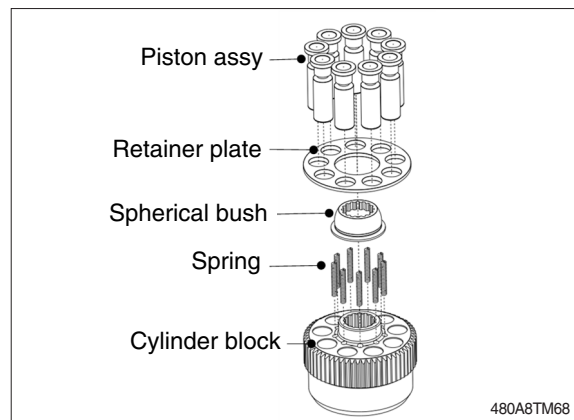

(22) Apply hydraulic fluid to the shoe.

Assemble the cylinder block assembly to drive shaft.

Apply hydraulic fluid to the cylinder block polishing surface.

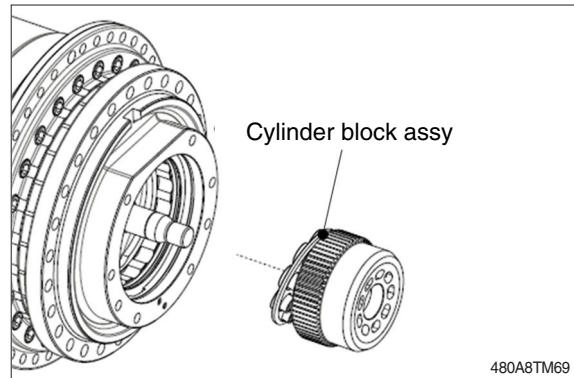

(23) Assemble the O-ring to the motor casing.

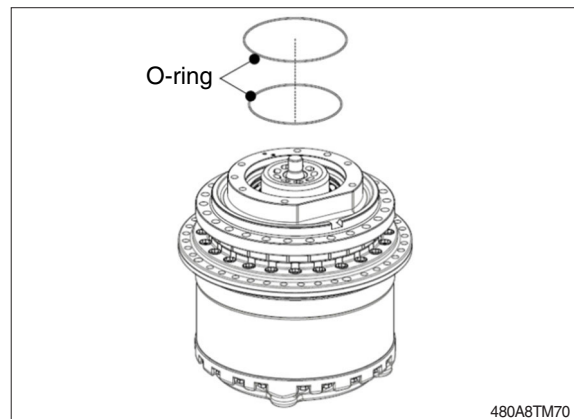

(24) Assemble the friction plate, separation plate to the motor casing in turn.

※ Be careful that the friction plate is in contact with the brake piston.

Assemble the brake piston to motor casing.

Check the brake piston is assembled completely to tap the the brake piston with a plastic hammer.

※ Quantity of friction plates and separation plates could be different of each model.

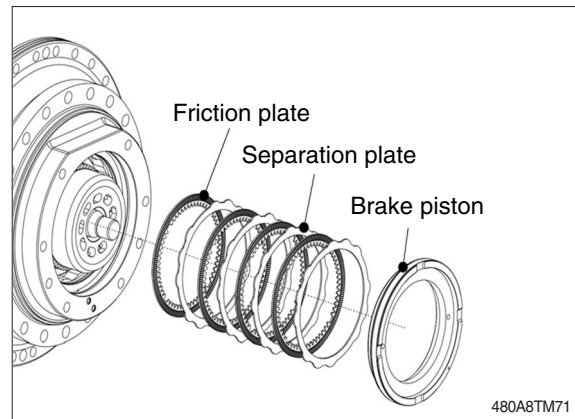

(25) Assemble the O-ring to the motor casing.

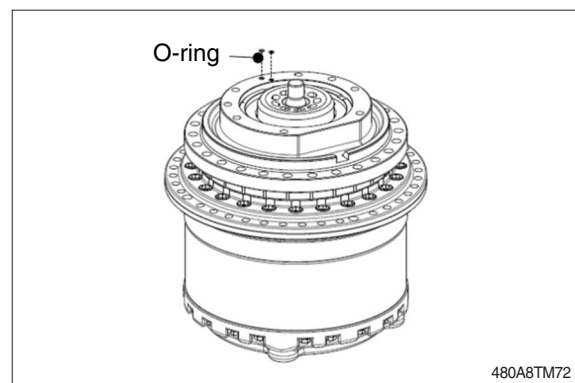

(26) Assemble the needle bearing to the valve casing.

Apply grease to the inner race of ball bearing.

Assemble the O-ring to the valve casing.

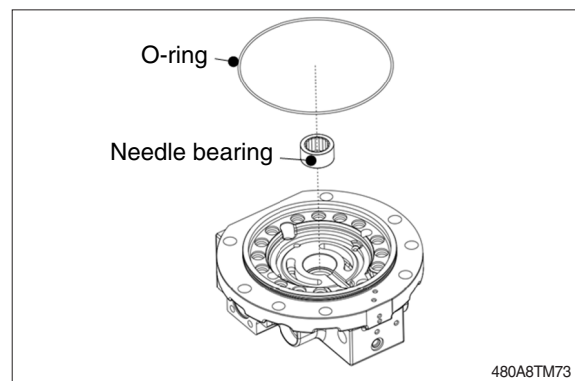

(27) Apply grease to the other side of the valve plate and assemble a valve plate and pin to valve casing.

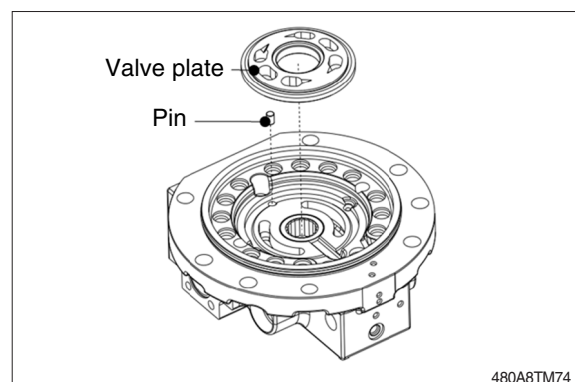

(28) Apply grease to brake spring and assemble it to the valve casing.

- ※ Quantity of brake springs could be different of each model.

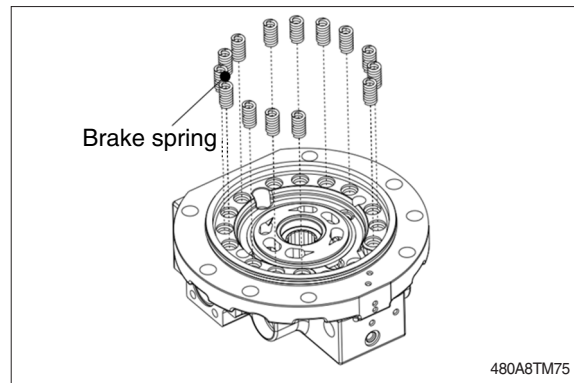

(29) Assemble the valve casing to the motor casing.

- ※ Required tools : guide pin
- ※ Guide pin size : M20x2.5x45 (total length 150 mm or more)

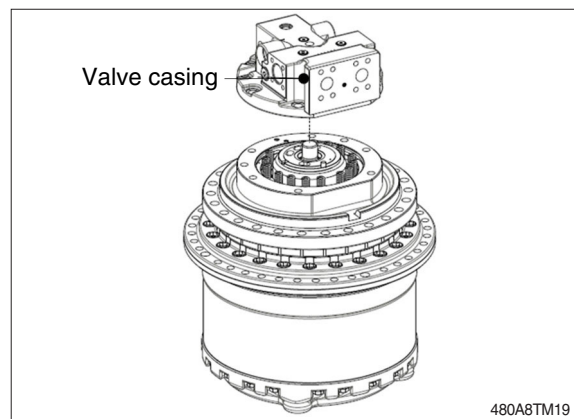

(30) Tighten each bolt evenly to assemble.

- ※ Required tools : torque wrench, hex bit 17 mm.
- ※ Bolt size : M20x2.5
- ※ Tightening torque : 50.3 ± 8.0 kgf · m
(364 ± 57.9 lbf · ft)

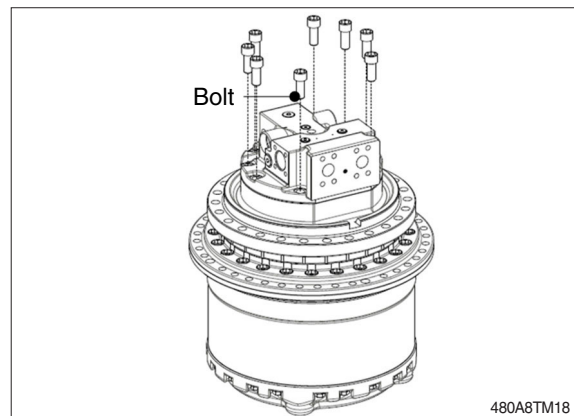

(31) Assemble the relief valve to valve casing.

- ※ Required tools : torque wrench, hex socket 41 mm.
- ※ Tap size : M33x1.5
- ※ Tightening torque : 18.0 ± 3.6 kgf · m
(130 ± 26.0 lbf · ft)

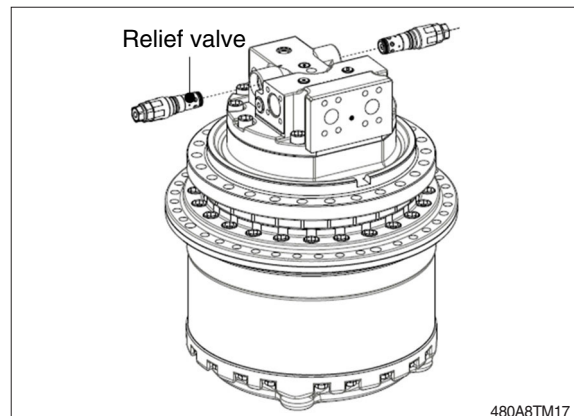

(32) Assemble the 2 speed spool, spring to valve casing.

- ※ Damage caution of 2 speed spool surface.

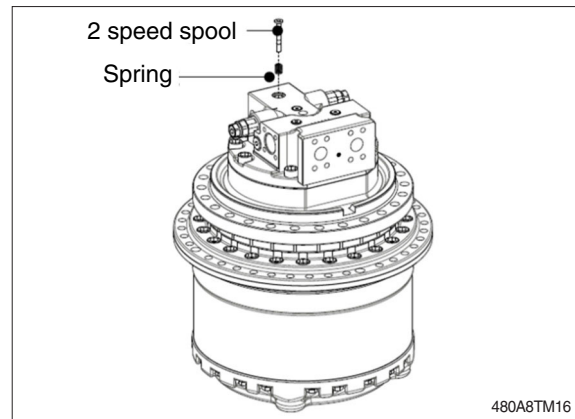

(33) Assemble the HS plug to valve casing.

- ※ Required tools : torque wrench, hex bit 10 mm.
- ※ Bolt size : G 1/2
- ※ Tightening torque : 10.0 ± 2.0 kgf·m
(72.3 ± 14.5 lbf·ft)

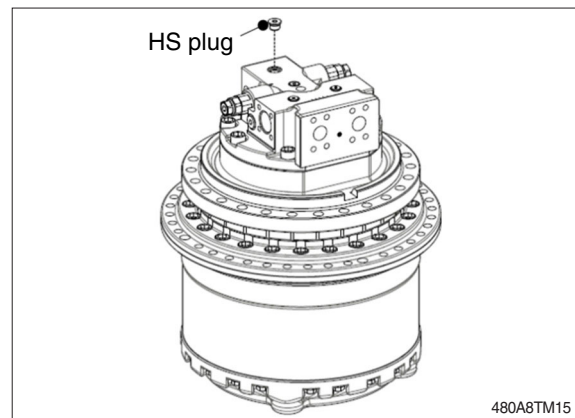

(34) Assemble the reducing valve and spring to valve casing.

- ※ Damage caution of reducing valve surface.

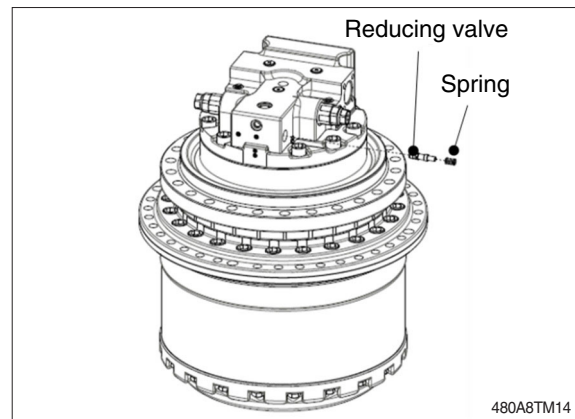

(35) Assemble the HS plug to valve casing.

- ※ Required tools : torque wrench, hex bit 8 mm.
- ※ Bolt size : G 3/8
- ※ Tightening torque : 6.0 ± 1.5 kgf·m
(43.4 ± 10.8 lbf·ft)

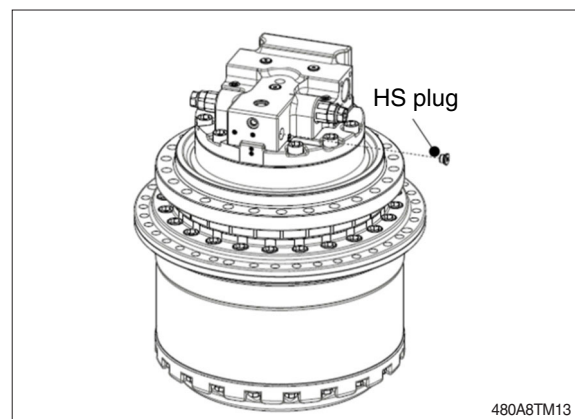

(36) Apply hydraulic fluid to counterbalance spool assy outer diameter and rotate the counterbalance spool assy slowly to assemble.

- ※ Damage caution of counterbalance spool surface.

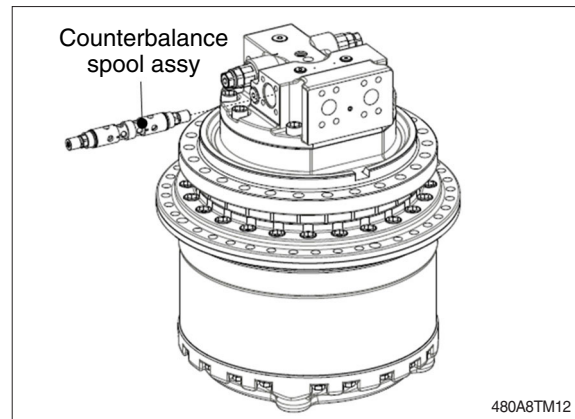

(37) Assemble the spring, spring seat, O-ring and washer to the valve casing.

- ※ Assemble the counterbalance plug and bolt to valve casing.

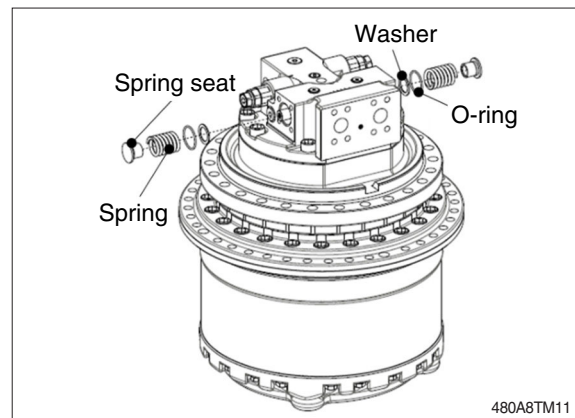

(38) Assemble the counterbalance plug and bolt to valve casing.

- ※ Required tools : torque wrench, hex bit 10 mm.
- ※ Bolt size : M12x1.75
- ※ Tightening torque : 10.4 ± 1.6 kgf·m
(75.2 ± 11.6 lbf·ft)

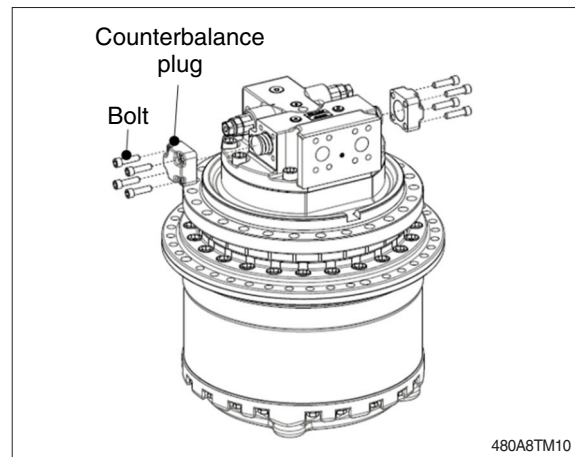

4) CHECKLIST AFTER ASSEMBLY

- (1) Supply sufficient hydraulic fluid to the hydraulic motor part, fill the reduction gear with the appropriate amount of reduction gear oil and then perform a trial run.
- (2) In a trial run, perform rotation test at low speed under no load and then a jack up test after mounted on equipment.