

GROUP 2 ENGINE SYSTEM

ENGINE AND ACCESSORIES MOUNTING

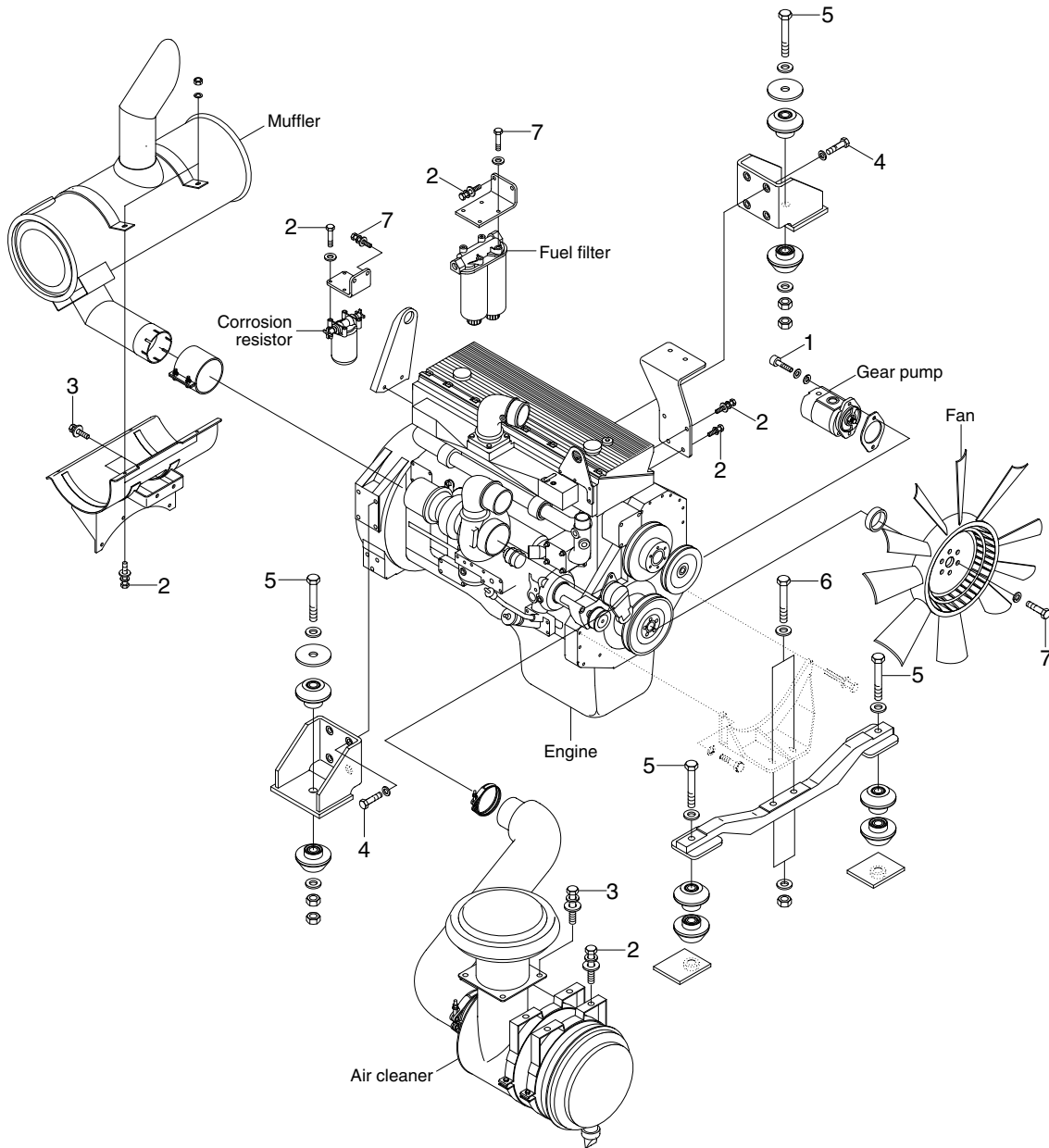

4809S9CM01

· Tightening torque

Item	Size	kgf · m	lbf · ft
1	M 8×1.25	2.5±0.5	18.1±3.6
2	M10×1.5	6.9±1.4	49.9±10.1
3	M12×1.75	12.3±2.4	88.9±17.3
4	M16×2.0	29.7±5.0	215±36.1

Item	Size	kgf · m	lbf · ft
5	M20×2.5	46.4±4.0	336±29.0
6	M20×2.5	57.9±8.7	419±62.9
7	3/8-16UNC	6.1±1.0	44±7.2

COOLING SYSTEM AND FUEL TANK MOUNTING

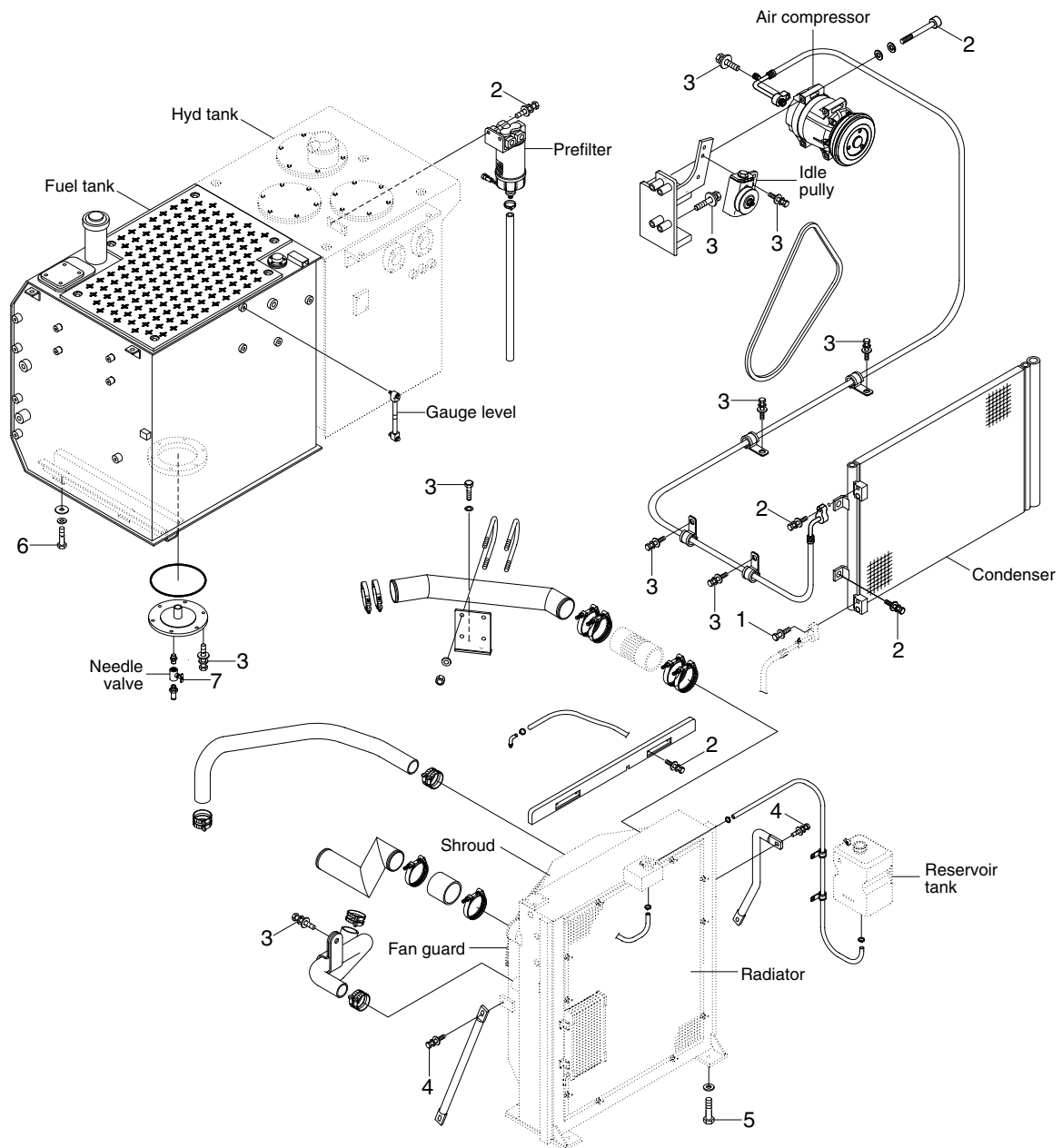

4809S9CM02

· Tightening torque

Item	Size	kgf · m	lbf · ft
1	M 6×1.0	1.05±0.2	7.6±1.45
2	M 8×1.25	2.5±0.5	18.1±3.6
3	M10×1.5	6.9±1.4	49.9±10.1
4	M12×1.75	12.8±3.0	92.6±21.7

Item	Size	kgf · m	lbf · ft
5	M16×2.0	29.7±4.4	126±31.8
6	M20×2.5	45±5.1	325±37
7	-	2.3±0.6	16.6±4.3