

GROUP 5 SWING DEVICE

1. REMOVAL AND INSTALL OF MOTOR

1) REMOVAL

- (1) Lower the work equipment to the ground and stop the engine.
- (2) Operate the control levers and pedals several times to release the remaining pressure in the hydraulic piping.
- (3) Loosen the breather slowly to release the pressure inside the hydraulic tank.

▲ Escaping fluid under pressure can penetrate the skin causing serious injury.

※ When pipes and hoses are disconnected, the oil inside the piping will flow out, so catch it in oil pan.

- (4) Disconnect hose assembly (2).
- (5) Disconnect pilot line hoses (3, 4, 5, 6, 7).
- (6) Sling the swing motor assembly (1) and remove the swing motor mounting bolts (8).

· Motor device weight : 61 kg (135 lb)

- (7) Remove the swing motor assembly.
※ When removing the swing motor assembly, check that all the piping have been disconnected.

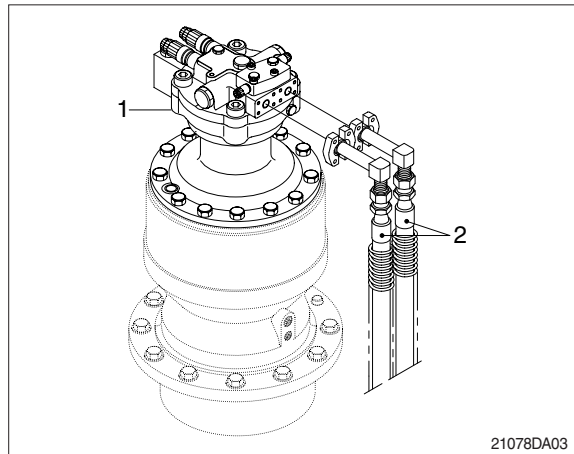

2) INSTALL

- (1) Carry out installation in the reverse order to removal.
- (2) Bleed the air from the swing motor.
 - ① Remove the air vent plug.
 - ② Pour in hydraulic oil until it overflows from the port.
 - ③ Tighten plug lightly.
 - ④ Start the engine, run at low idling and check oil come out from plug.
 - ⑤ Tighten plug fully.
- (3) Confirm the hydraulic oil level and check the hydraulic oil leak or not.

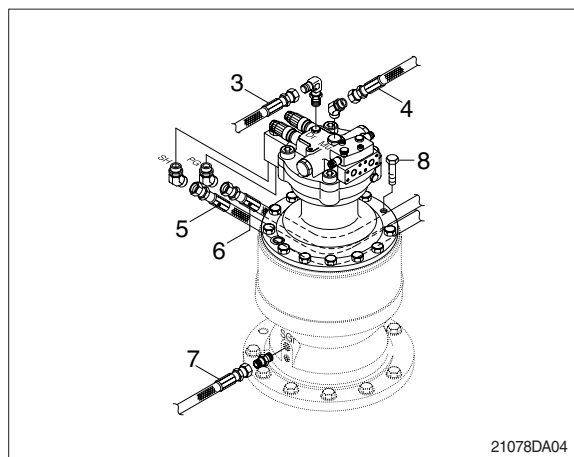

2. DISASSEMBLY AND ASSEMBLY OF SWING MOTOR

1) STRUCTURE

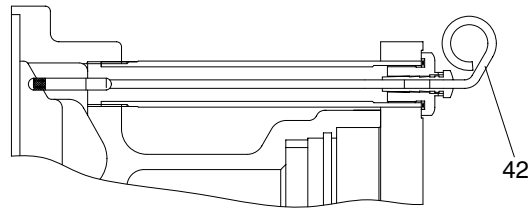

DETAIL K

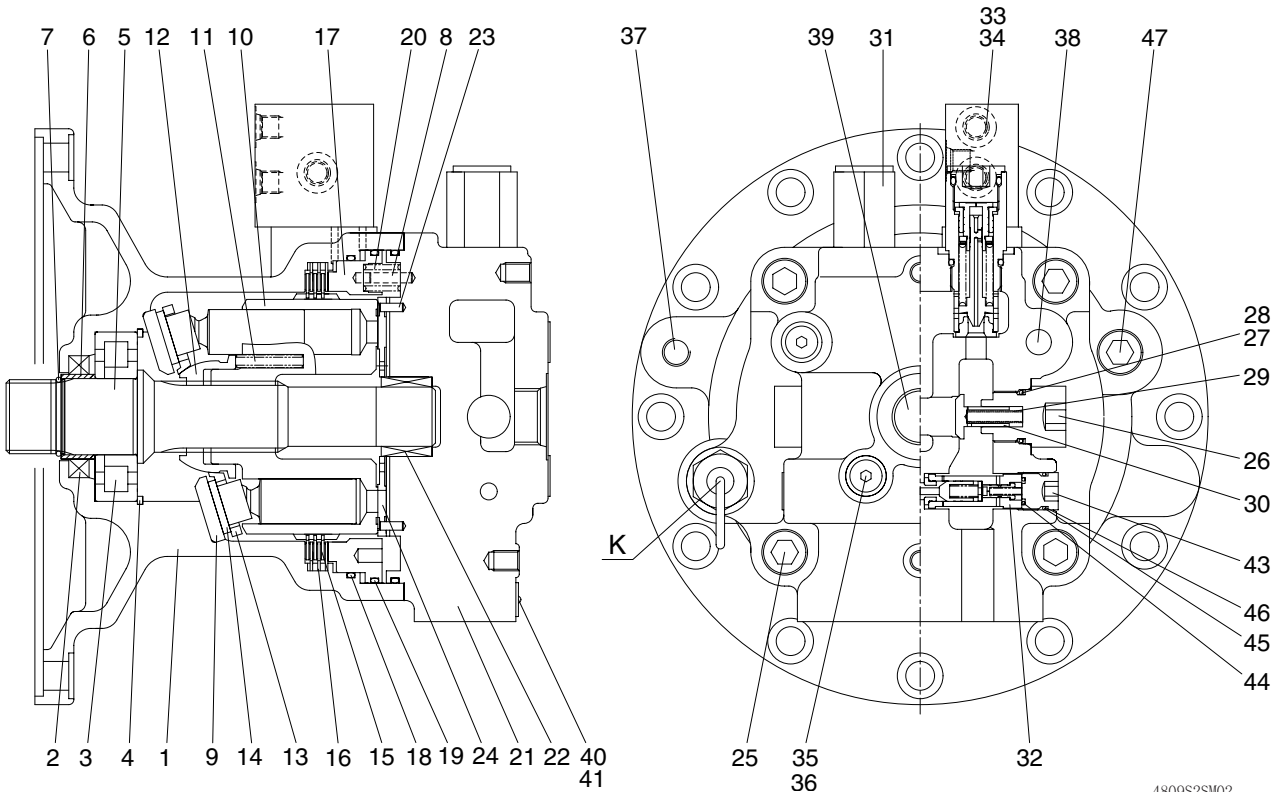

4809S2SM02

1	Body	17	Brake piston	33	Time delay valve
2	Oil seal	18	O-ring	34	Wrench bolt
3	Roller bearing	19	O-ring	35	Plug
4	Snap ring	20	Spring	36	O-ring
5	Shaft	21	Rear cover	37	Plug
6	Bushing	22	Needle bearing	38	Plug
7	Stop ring	23	Pin	39	Plug
8	Pin	24	Valve plate	40	Name plate
9	Shoe plate	25	Wrench bolt	41	Rivet
10	Cylinder block	26	Plug	42	Level gauge
11	Spring	27	Back up ring	43	Plug
12	Ball guide	28	O-ring	44	O-ring
13	Set plate	29	Spring	45	O-ring
14	Piston assy	30	Check	46	Back up ring
15	Friction plate	31	Relief valve	47	Plug
16	Plate	32	Anti-inversion valve		

2) DISASSEMBLING

(1) Disassembly the sub of a TURNING AXIS

- ① Unloosing wrench bolt and disassemble time delay valve assy (35) from rear cover (21).

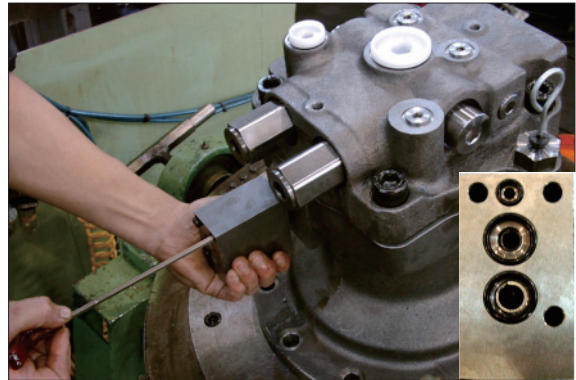

14078SM201/201A

- ② Disassemble level gauge (42) from body (1).

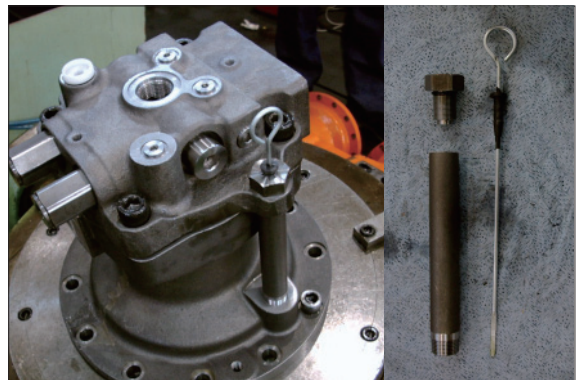

14078SM202/202A

- ③ Hang rear cover (21) on hoist, unloose wrench bolt (25) and disassemble from body (1).



14078SM203/203A

- ④ Using a jig, disassemble break piston (17) from body (1).

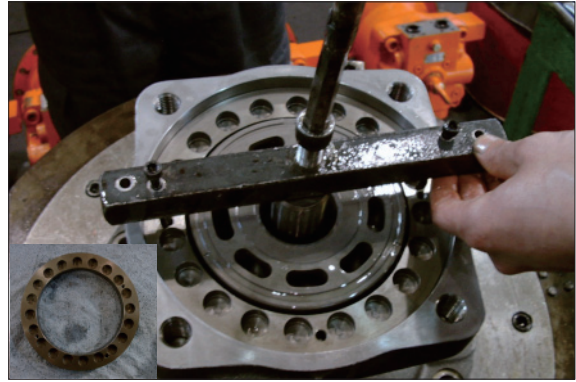

14078SM204/204A

- ⑤ Disassemble respectively cylinder block assy, friction plate (15), plate (16) from body (1).

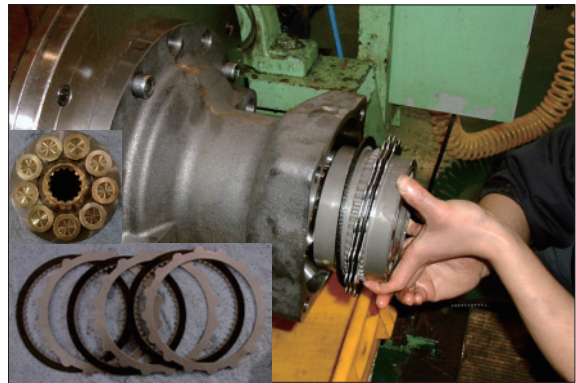

14078SM205/205A/B

(2) Disassemble cylinder block assy sub

- ① Disassemble piston assy (14), set plate (13) from cylinder block assy.



14078SM206/205B

- ② Disassemble ball guide (12) from cylinder block (10).

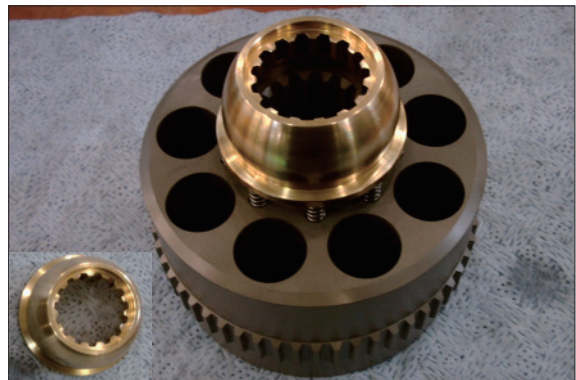

14078SM207/207A

- ③ Disassemble spring (11) from cylinder block (10).

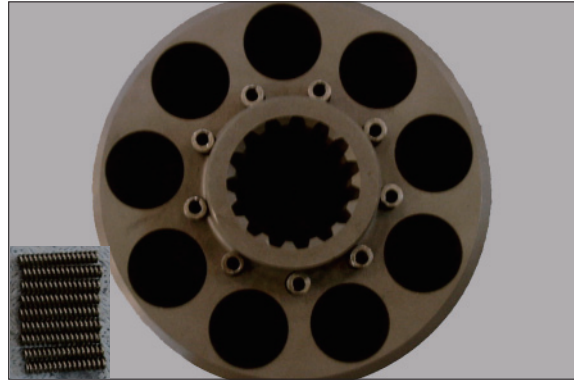

14078SM208/208A

- ④ Disassemble shoe plate (9) from body (1).

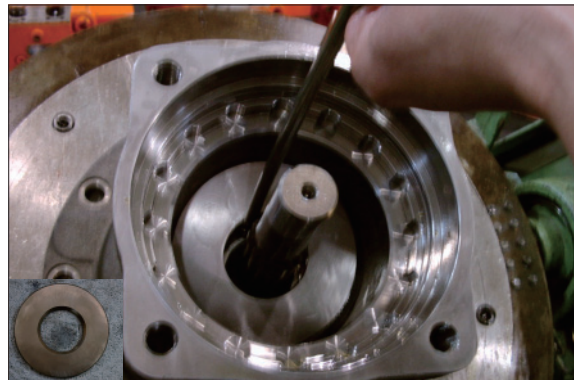

14078SM209/209A

- ⑤ Using a plier jig, disassemble snap ring (4) from shaft (5).



14078SM210/210A

- ⑥ Disassemble shaft assy from body (1).

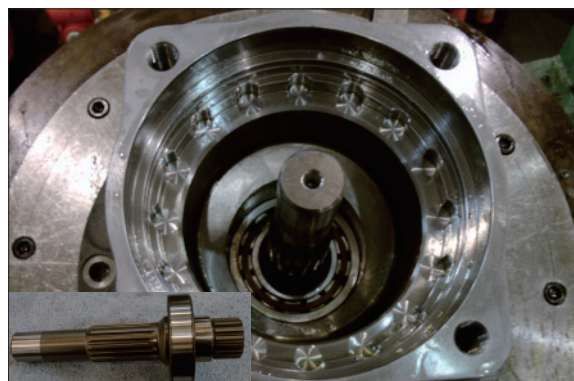

14078SM211/211A

(3) Disassemble rear cover assy sub

- ① Disassemble pin (8, 23), valve plate (24) from rear cover (21).

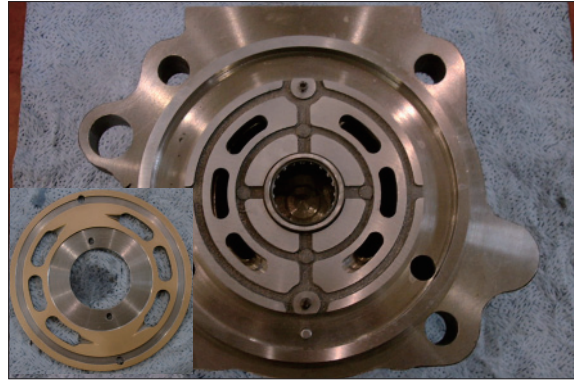

14078SM212/212A

- ② Using a torque wrench, disassemble relief valve assy (31) 2 set from rear cover (21).



14078SM213/213A

- ③ After disassembling plug with a L-wrench from rear cover (21), disassemble respectively back up ring, O-ring, O-ring, spring, anti-inversion valve assy (32)

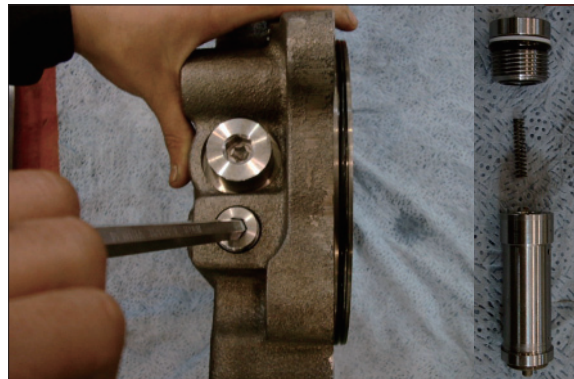

14078SM214/214A

- ④ Disassemble make up check valve assy with a torque wrench from rear cover (21).

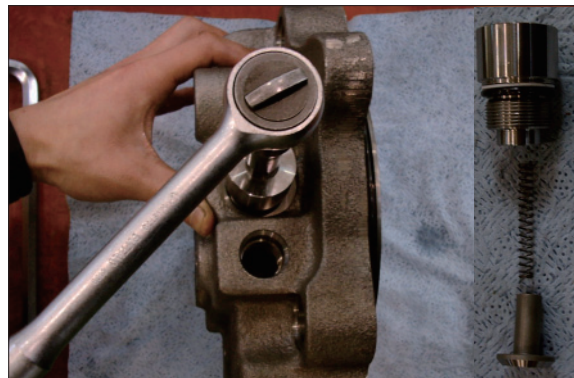

14078SM215/215A

- ⑤ Disassemble respectively plug (35, 38, 39), with a L-wrench from rear cover (21).

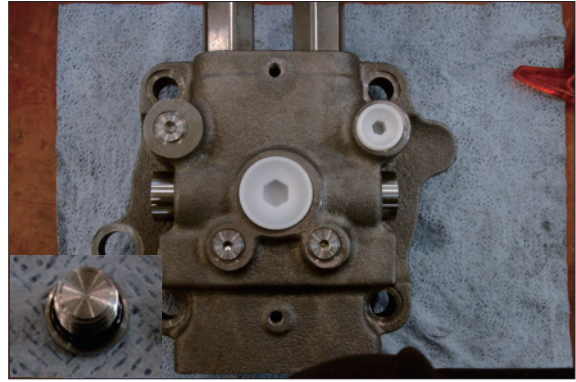

14078SM216/216A

3) ASSEMBLING

(1) Assemble the sub of a turning axls

- ① Put roller bearing (3), bushing (6) on pre-heater and provide heat to inner wheel (compressing temp : 290°C for 2minutes)
 - Roller bearing × 1EA
 - Bushing × 1EA

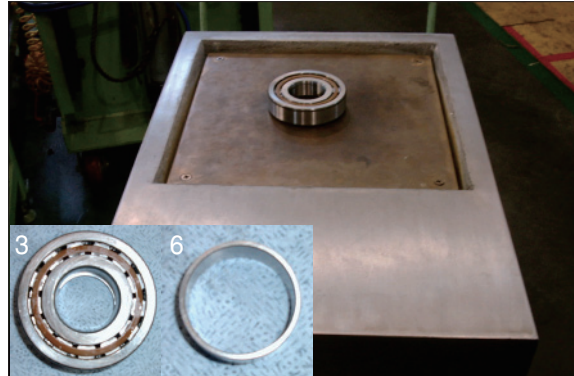

14078SM217/217A/B

- ② After assembling and compressing preheated roller bearing (3), bushing (6) into shaft (5).
 - Stop ring × 1EA
 - Shaft × 1EA

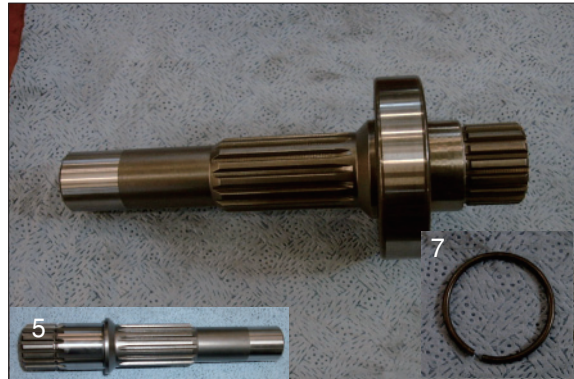

14078SM218/218A/B

- ③ Put body (1) on a assembling jig, fix it with bolts to prohibit moving.

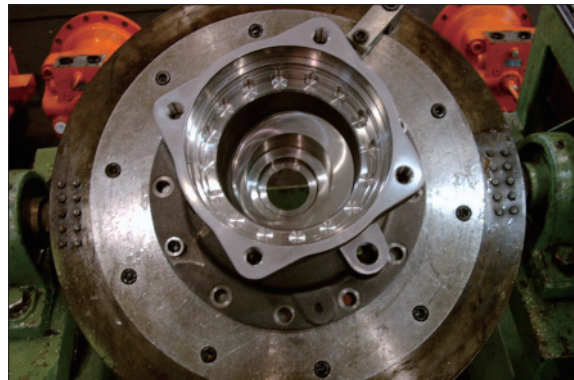

14078SM219

- ④ Using a compressing tool and steel stick, assemble oil seal (2) into body (1).
· Oil seal × 1EA

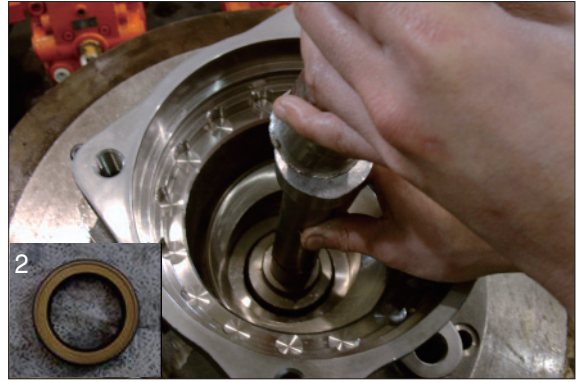

14078SM220/220A

- ⑤ Insert above shaft sub into body (1) and assemble it with a steel stick.

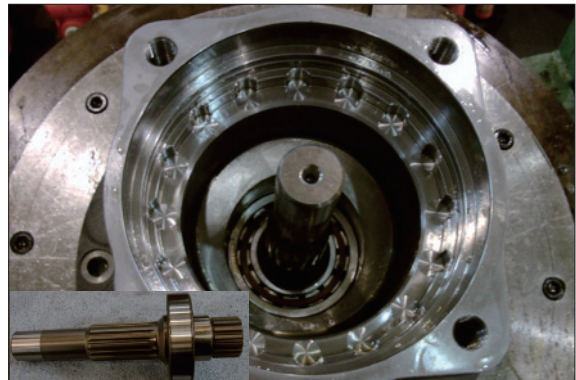

14078SM211/211A

- ⑥ Fix snap ring (4) to shaft with a plier jig.
- Snap ring × 1EA

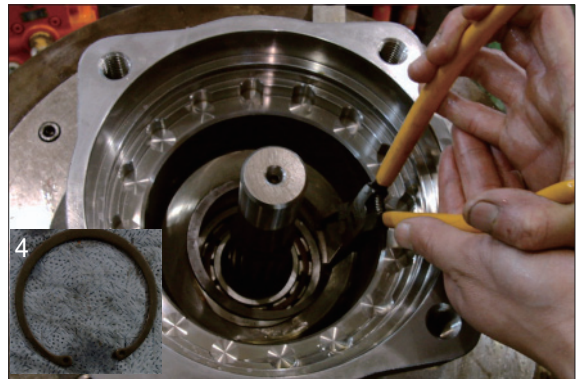

14078SM210/210A

- ⑦ Spread grease on shoe plate (9) and assemble on the body.
- Shoe plate × 1EA

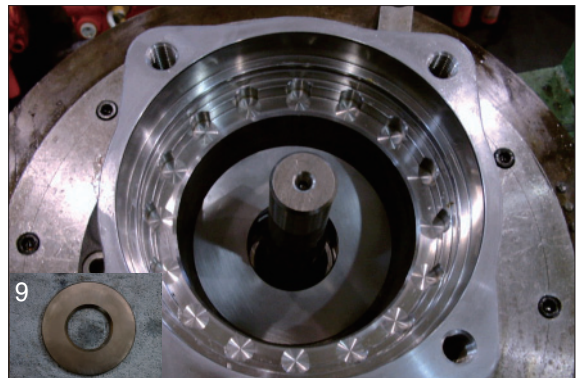

14078SM222/209A

(2) Assemble the sub of cylinder block assy

- ① Assemble spring (11) 9 set into cylinder block (10).
· Spring × 9EA

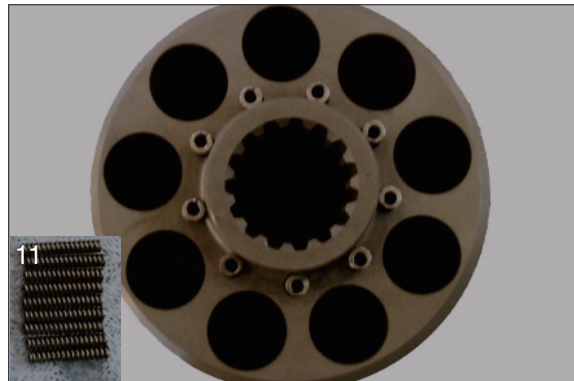

14078SM208/208A

- ② Assemble ball guide (12) into cylinder.
· Ball guide × 1EA

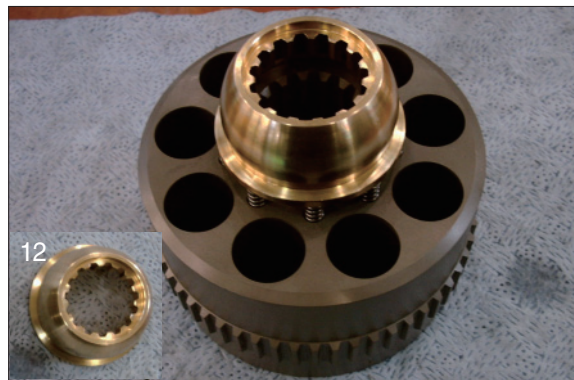

14078SM207/207A

- ③ Assemble piston assy (14) 9 set into set plate (13).
- Piston assy × 9EA
· SET plate × 1EA



14078SM223/223A

- ④ Assemble above item ② and ③.

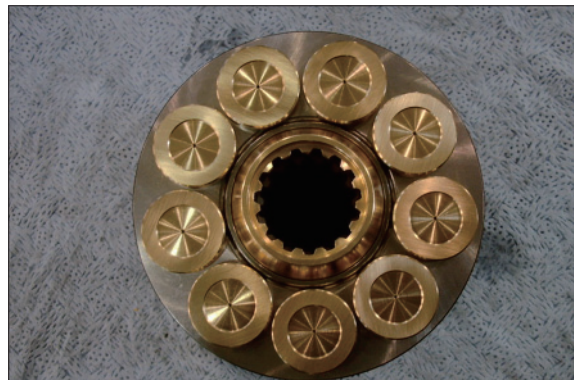

14078SM224

- ⑤ Assemble cylinder block assy into body (1).

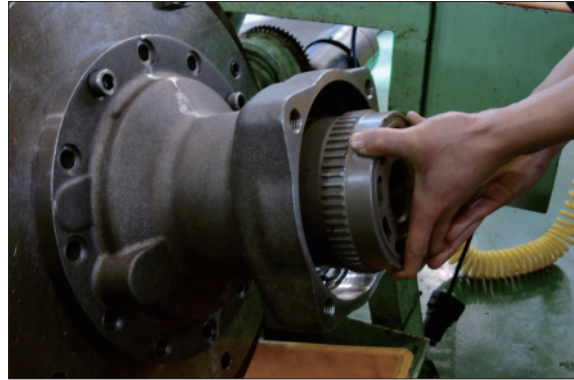

14078SM225

- ⑥ Assemble O-ring (18) into body (1).
· O-ring × 1EA

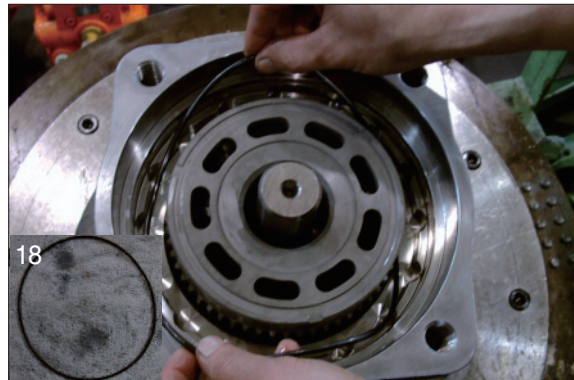

14078SM226/226A

- ⑦ Assemble 3 set of plate (16), friction plate (15) respectively into body.
· Plate × 3EA
· Friction plate × 3EA

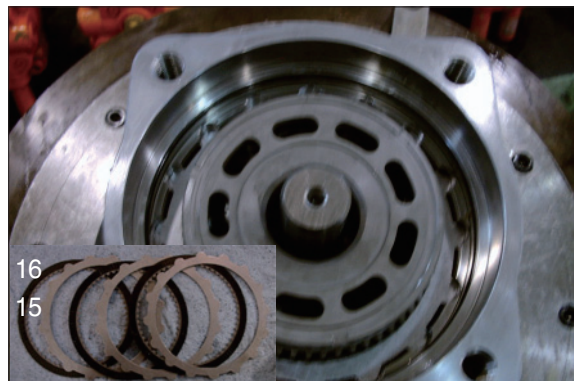

14078SM227/205A

- ⑧ Assemble O-ring (19) into break piston (17).
· O-ring × 2EA



14078SM228/226A

- ⑨ Insert break piston assy into body (1) and compress it with a jig and hammer.

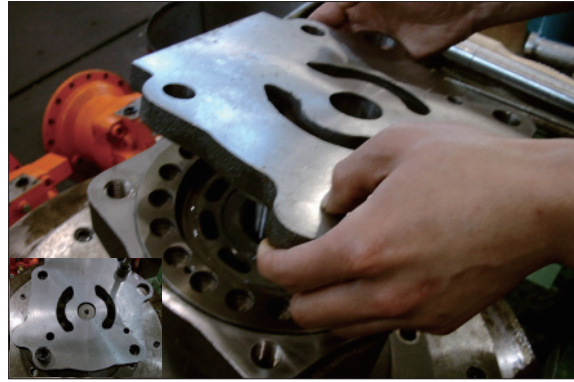

14078SM229/229A

- ⑩ Assemble spring (20) (20EA) into break piston (17).
 · Spring × 20EA

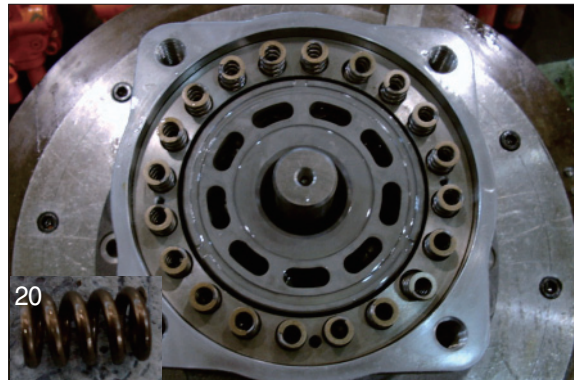

14078SM230/230A

(3) Assemble the sub of rear cover assy sub

- ① Assemble the sub of make up check valve assy.
 Assemble O-ring (28), back up ring (27) into plug (26) with a O-ring assembling jig.
 · Plug × 1EA
 · Back up ring × 1EA
 · O-ring × 1EA

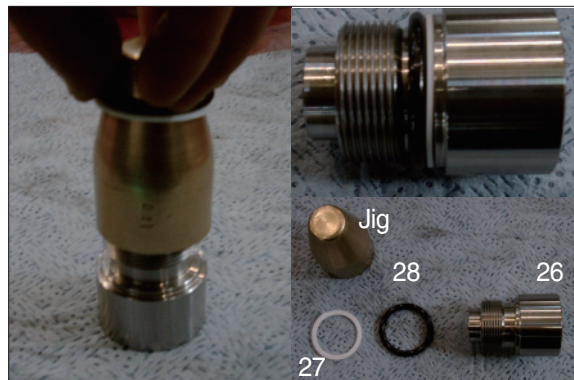

14078SM231/231A/B

- ② Assemble respectively make up check valve assy spring (29), check (30), plug (26) into rear cover (21) after then screw it torque wrench.
 · Make up check sub × 2set
 · Spring × 2EA
 · Check × 3EA

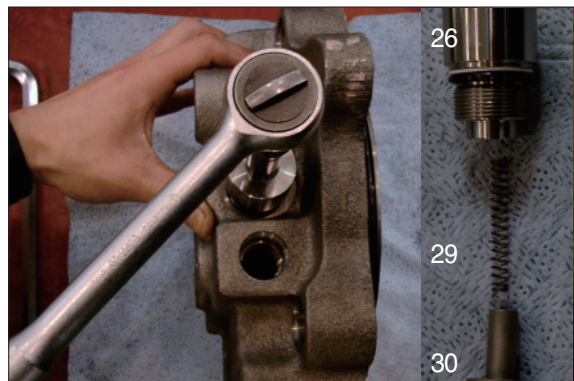

14078SM215/215A

- ③ Assemble respectively plug (43), back up ring, O-ring, O-ring, spring, anti-rotating valve assy (32) into rear cover (21).
(Bilateral symmetry assembling)
- Anti-Inversion v/v assy × 2set
 - O-ring (P12) × 2EA
 - O-ring (P18) × 2EA
 - Back up ring (P18) × 2EA

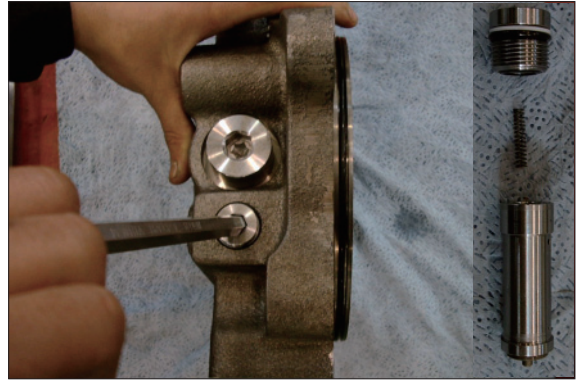

14078SM214/214A

- ④ Assemble relief valve assy (31) 2set into rear cover (21) with a torque wrench.
(Bilateral symmetry assembling)

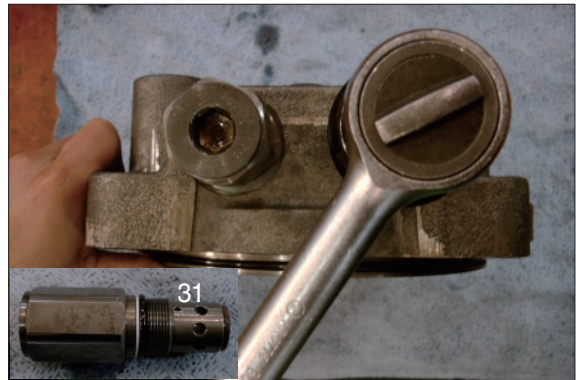

14078SM213/213A

- ⑤ Assemble plug (35), plug (37, 38) into rear cover (21) with a L-wrench.
* Plug × 3EA (PF1/4)

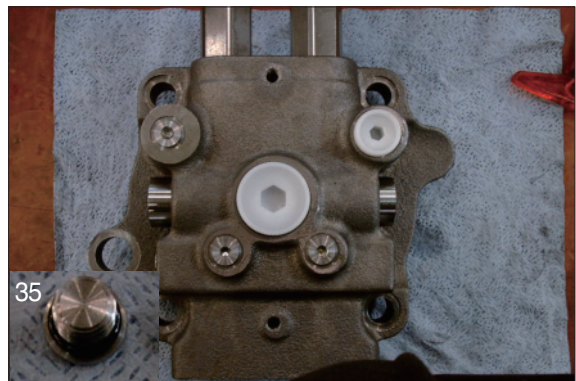

14078SM216/216A

- ⑥ After assembling needle bearing (22) into rear cover (21), with a hammer assemble pin (8, 23).
* Pin × 1EA
* Pin × 2EA

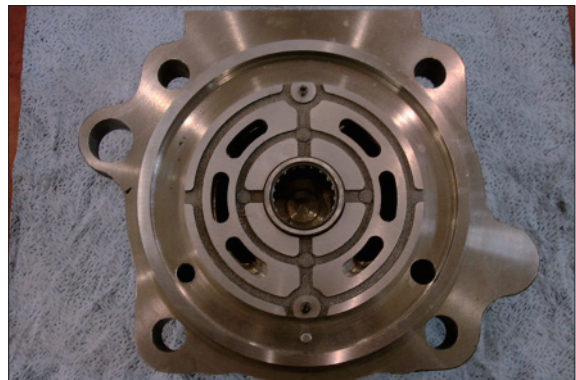

14078SM212

- ⑦ Spreading grease on valve plate (24),
assemble into rear cover (21).
· Valve plate × 1EA

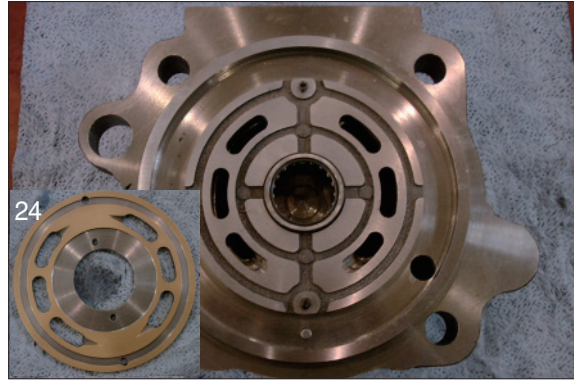

14078SM212/212A

- ⑧ Lift up rear cover assy on body (1) by a crane and assemble it with a wrench bolt (25).

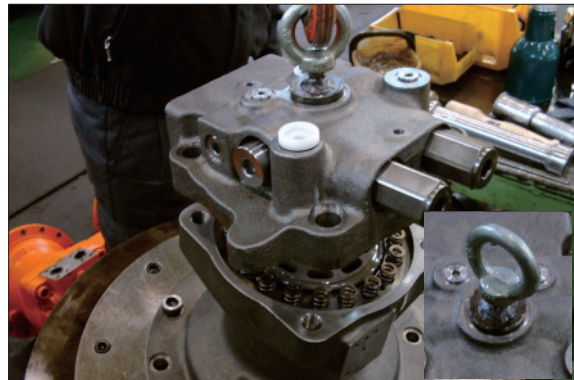

14078SM203/203A

- ⑨ Assemble level gauge (42) into body (1).

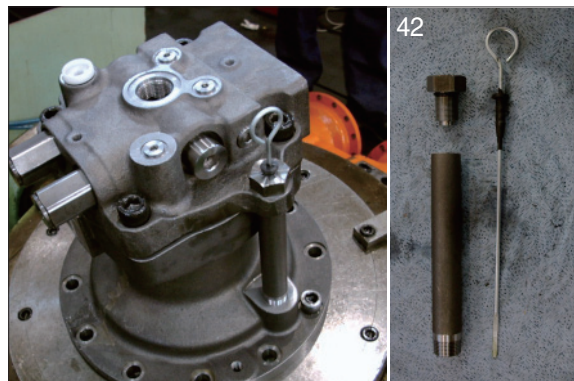

14078SM202/202A

- ⑩ Assemble time delay valve assy (33) into rear cover (21) with a wrench bolt (34).

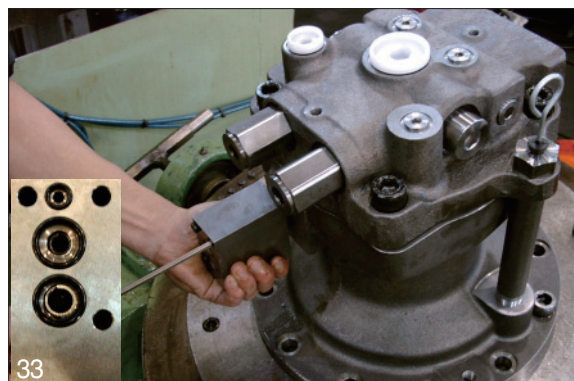

14078SM01/201A

(4) Air pressing test

Be sure of leakage, after press air into assembled motor

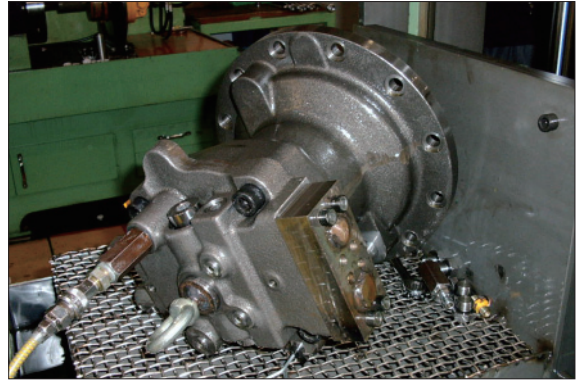

14078SM232

(5) Leakage check

After cleaning motor by color check No.1, paint No.3 and be sure of leakage.

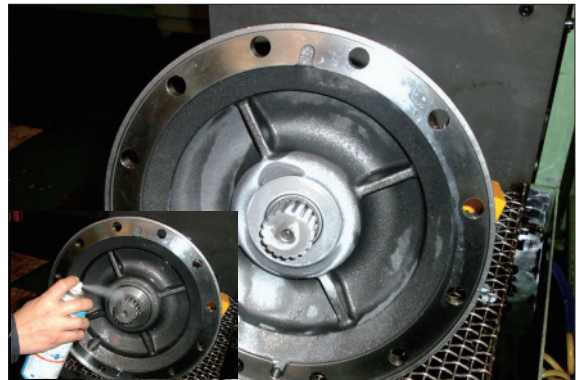

14078SM233/233A

(6) Mount test bench

Mounting motor test bench, test the availability of each part.

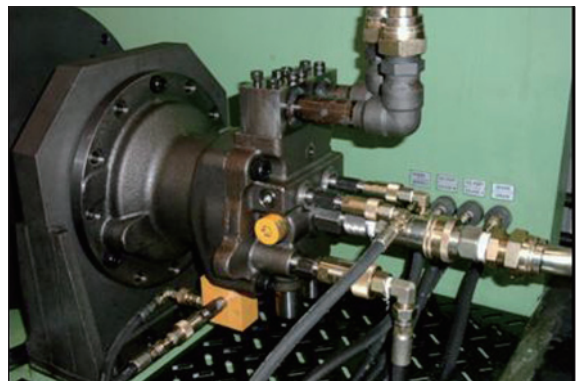

220078SM14

3. REMOVAL AND INSTALL OF REDUCTION GEAR

1) REMOVAL

- (1) Remove the swing motor assembly.
For details, see removal of swing motor assembly.
- (2) Sling reduction gear assembly (1) and remove mounting bolts (2).
- (3) Remove the reduction gear assembly.
 - Reduction gear device weight : 180 kgf · m
(396 lbf · ft)



2) INSTALL

- (1) Carry out installation in the reverse order to removal.
 - Tightening torque : 58.4 ± 6.4 kgf · m
(422 ± 46.3 lbf · ft)

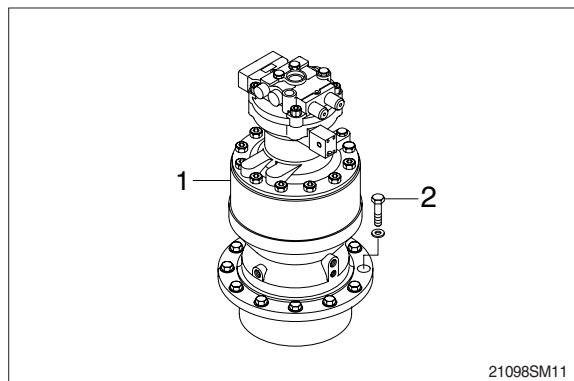

4. DISASSEMBLY AND ASSEMBLY OF REDUCTION GEAR

1) STRUCTURE

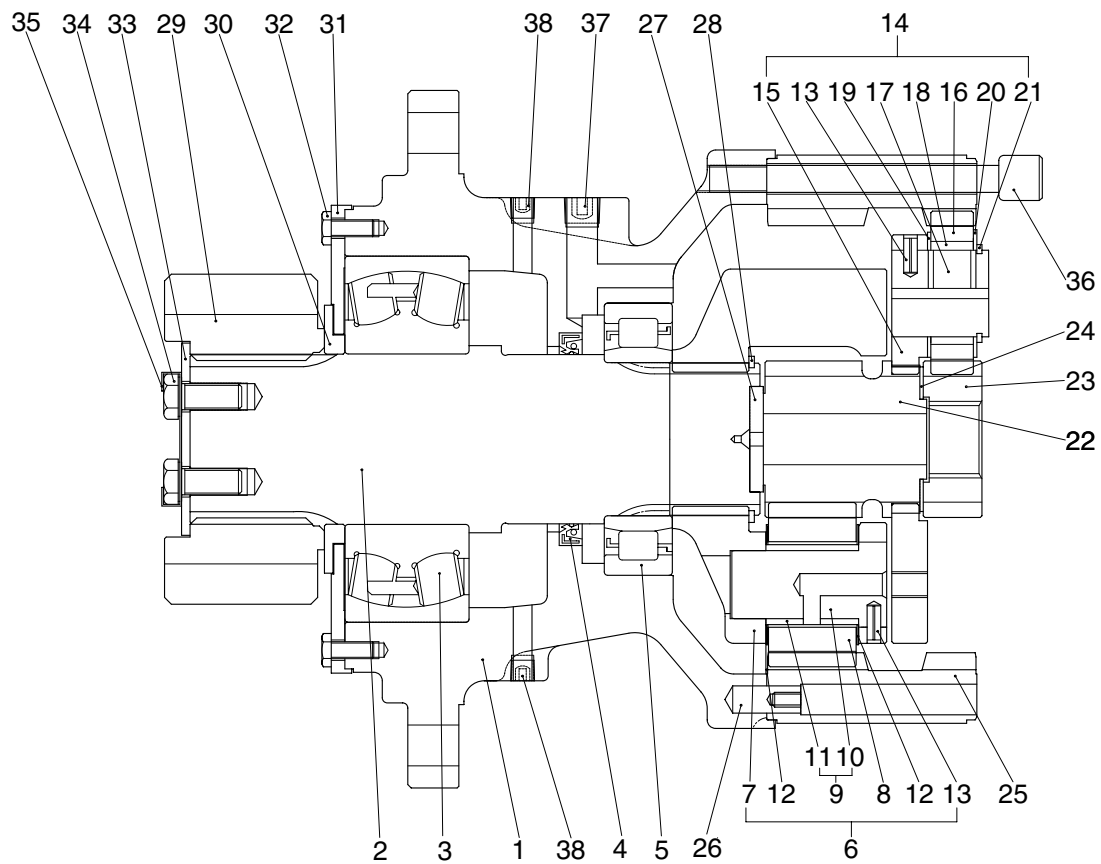

48092SM03

1	Casing	14	Carrier assy 1	27	Thrust plate 3
2	Drive shaft	15	Carrier 1	28	Stop ring
3	Roller bearing	16	Planet gear 1	29	Pinion gear
4	Oil seal	17	Pin 1	30	Spacer
5	Roller bearing	18	Needle cage	31	Cover plate
6	Carrier assy 2	19	Side plate 1	32	Hexagon bolt
7	Carrier 2	20	Side plate 2	33	Lock plate
8	Planet gear 2	21	Stop ring	34	Hexagon bolt
9	Pin assy 2	22	Sun gear 2	35	Lock washer
10	Pin 2	23	Sun gear 1	36	Socket bolt
11	Bush 2	24	Side plate 3	37	Plug
12	Thrust washer	25	Ring gear	38	Plug
13	Spring pin	26	Knock pin		

2) DISASSEMBLY

- (1) Spread off the 4 corners of lock washer (35) with a tool.
 - ※ Do not reuse lock washer (35).
- Loosen the bolts (34) and then remove lock washer (35) and lock plate (33) from the pinion gear (29).
- Remove pinion gear (29) and spacer (30) from the drive shaft (2).
- Remove cover plate (31) from the casing (1) by loosening the hexagon bolts (32).

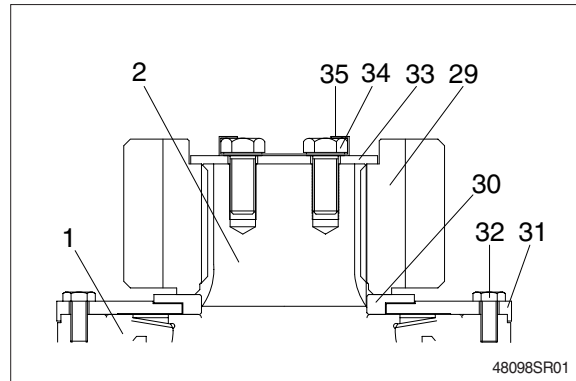

- (2) Remove gauge bar and gauge pipe from the swing motor casing.
- ※ Pour the gear oil out of reduction gear into the clean bowl to check out the friction decrease.

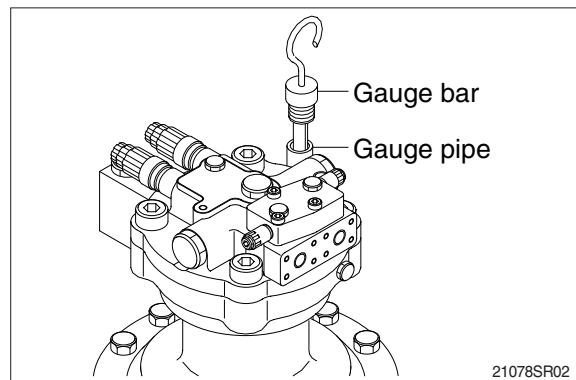

- (3) Loosen the socket bolts (36) to separate swing motor from reduction gear.

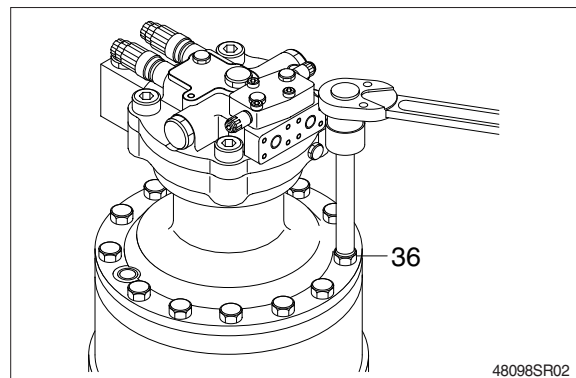

- (4) Tighten 3 M16 eye bolts to the ring gear (25) and then lift the ring gear (25) out of the casing (1).

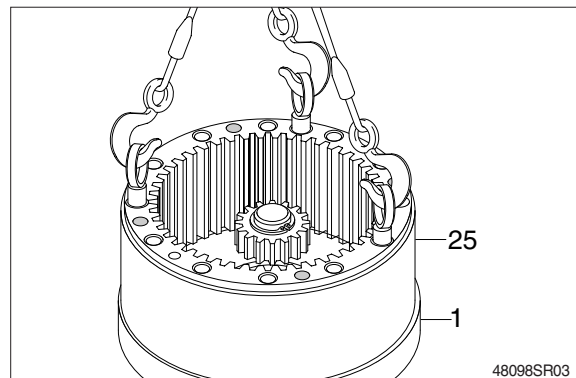

(5) Remove sun gear1 (23).

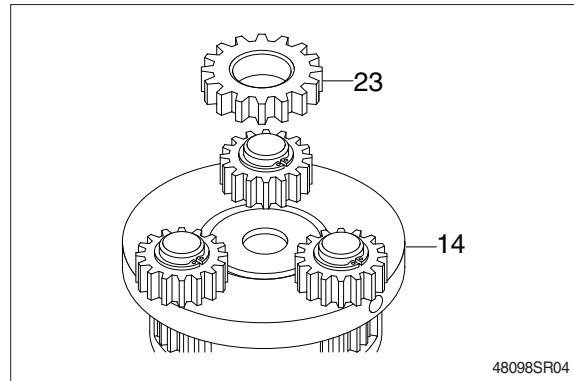

(6) Tighten two M10 eye bolts to carrier1 (14) and lift up and remove carrier1 (14) as subassembly.

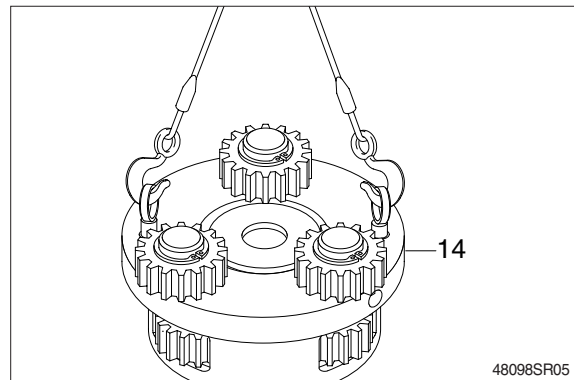

(7) Disassembling carrier1 (14) assembly.

- ① Remove stop ring (21).
 - ② Remove side plate2 (20), planet gear1 (16), needle cage (18), side plate1 (19) and side plate3 (24) from the carrier.
 - ③ Using M8 solid drill, crush spring pin (13) so that the pin1 (17) can be removed by hammering.
 - ④ Remove side plate3 (24) from carrier1 (14).
- ※ Do not reuse spring pin (13).
 - ※ Do not remove pin1 (17), carrier1 (14) and spring pin (13) but in case of replacement.
 - ※ Put matching marks on the planet gear1 (16) and the pin1 (38) for easy reassembly.

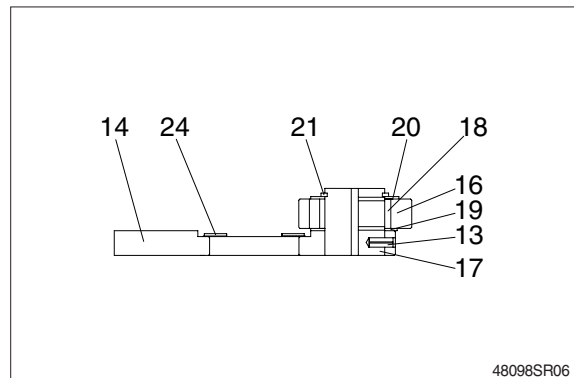

(8) Remove sun gear2 (22).

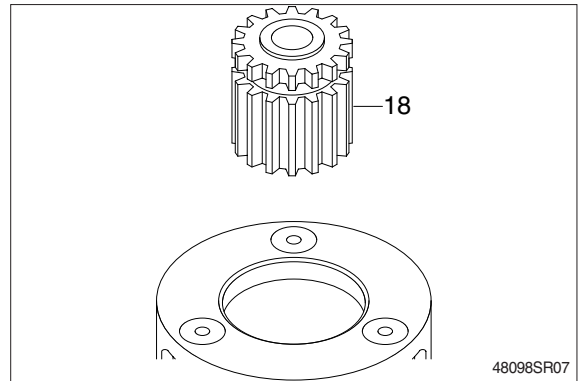

(9) Remove carrier2 (6) assembly from casing (1).

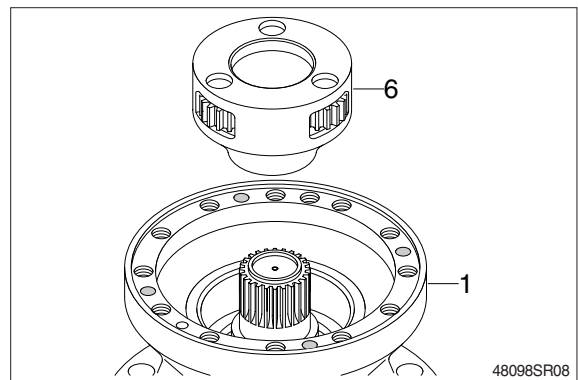

(10) Disassembling carrier 2 (6) assembly

① Using M8 solid drill, crush spring pin (13) so that the pin & bushing (10) can be removed.

※ Do not reuse spring pin (13).

② Remove pin & bushing (10), planet gear 2 (8) and bushing 2 (11) from the carrier 2 (9).

※ Put matching marks on the planet gear 2 (8) and the pin & bushing (10) for easy reassembly.

※ Do not disassemble pin & bushing (10), carrier 2 (6) and spring pin (13) but in case of replacement.

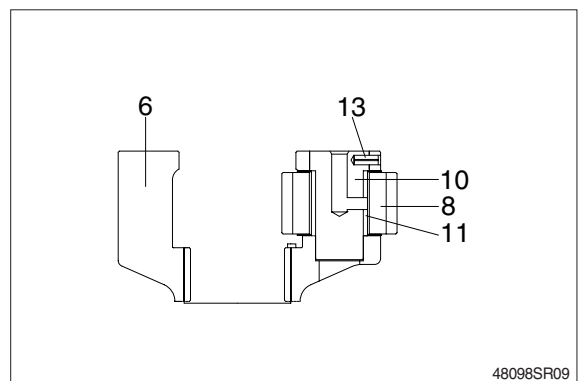

(11) Remove thrust plate (27) and stop ring (28) from the drive shaft (2).

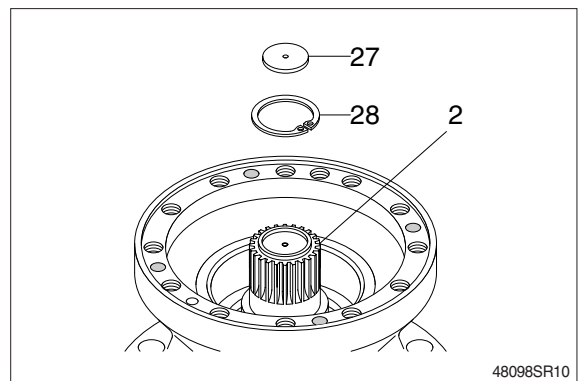

- (12) Remove drive shaft (2) with roller bearing (5) and oil seal (4) assembled.
Remove knock pin (26) from the casing (1).

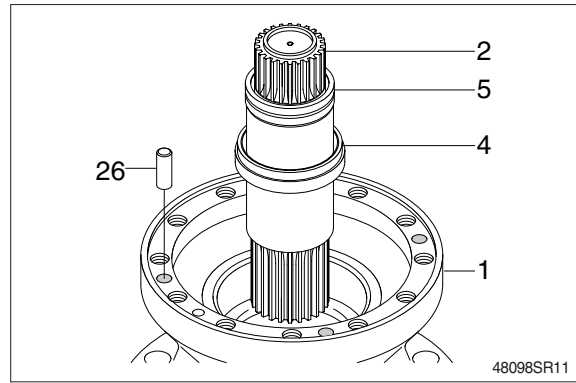

- (13) Remove roller bearing (5) and oil seal (4) from the drive shaft (2).
※ Do not reuse oil seal (4) once removed.

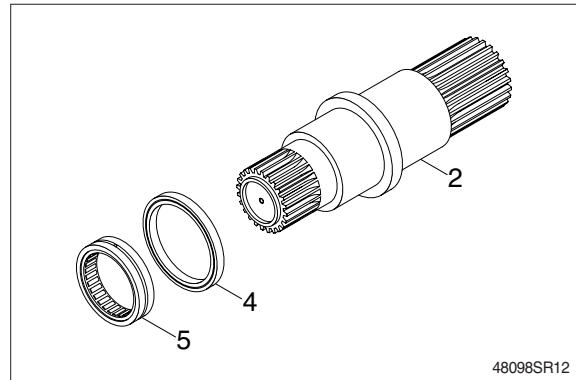

- (14) Using the bearing disassembly tool, remove roller bearing (3).

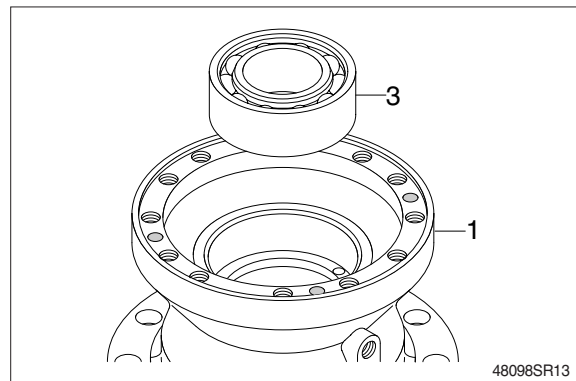

- (15) Remove plugs (37, 38) from the casing (1).

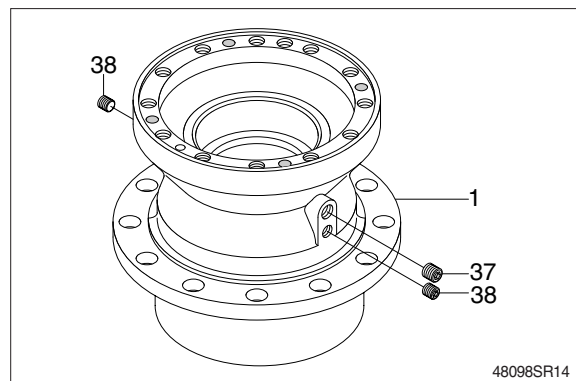

3) ASSEMBLY

- (1) Assemble roller bearing (3) inside the casing (1).

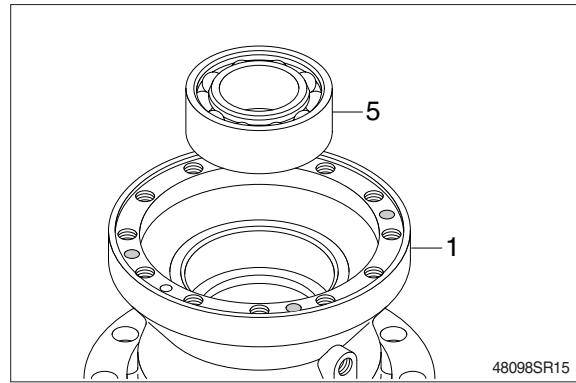

- (2) Assemble the drive shaft (2) into the casing (1) and then install oil seal (4) and roller bearing (5).

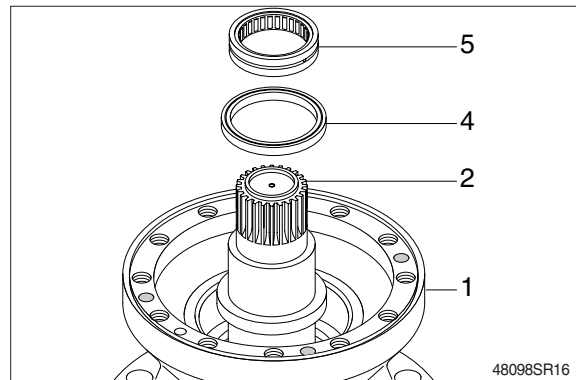

- (3) Install stop ring (28) and thrust plate (27) on top of drive shaft (2).

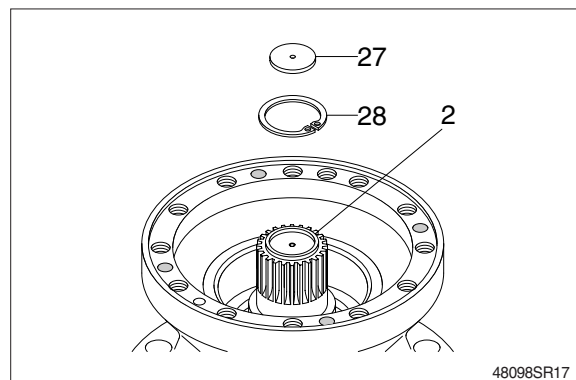

- (4) Assembling carrier2 (6) assembly.

- ① Install bushing 2 (11) inside the planet gear 2 (8) and then assemble them to the carrier 2 (6).
 - ② Assemble the pin & bushing (10) to the carrier 2 (6) and then press the spring pin (13) by hammering.
 - ③ Punch 2 points of the spring pin (13) lip.
- ※ Take care not to mistake the matching marks of each part.

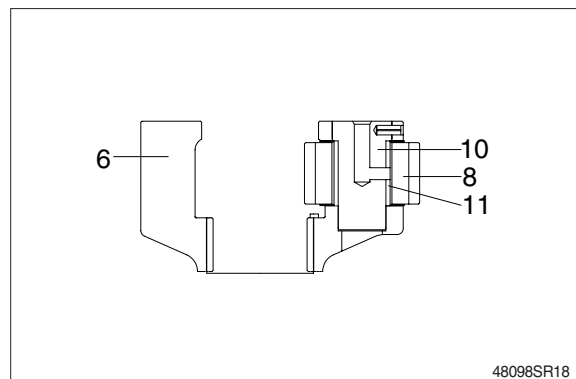

- (5) Assemble carrier 2 (6) assembly correctly to the drive shaft (2).

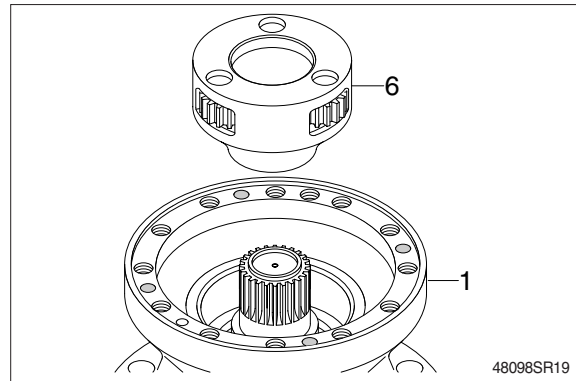

- (6) Assemble sun gear2 (22) to the center of the carrier2 (6) assembly.

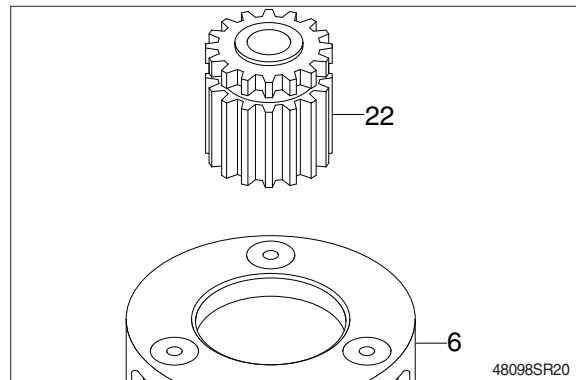

- (7) Assembling carrier1 (14) assembly.

- ① Assemble the pin1 (38) to the carrier1 (14) and then press the spring pin (13) by hammering.
 - ② Punch 2 points of the spring pin's (13) lip.
 - ③ Install side plate3 (24) onto the center of carrier1 (14).
 - ④ Install needle cage (18) into the planet gear1 (16).
 - ⑤ Assemble side plate (19), planet gear1 (16), side plate2 (20) and then stop ring (21) to the pin1 (17).
- ※ Take care not to mistake the matching marks of each part.

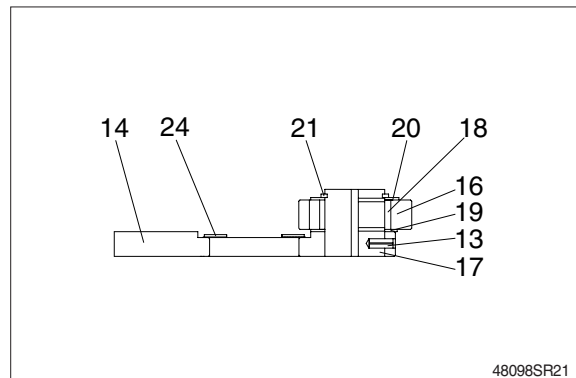

- (8) Install sun gear1 (23) onto the side plate3 (24).

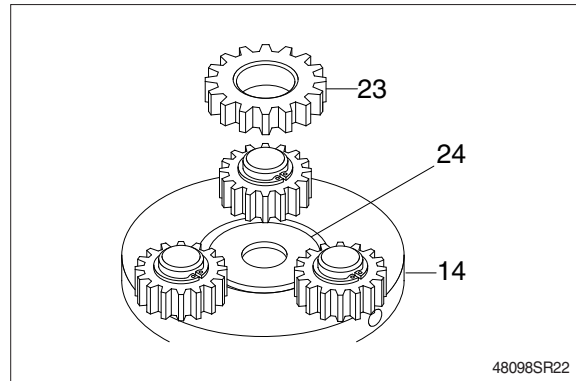

- (9) Assemble carrier 1 (14) assembly onto the carrier2 assembly.

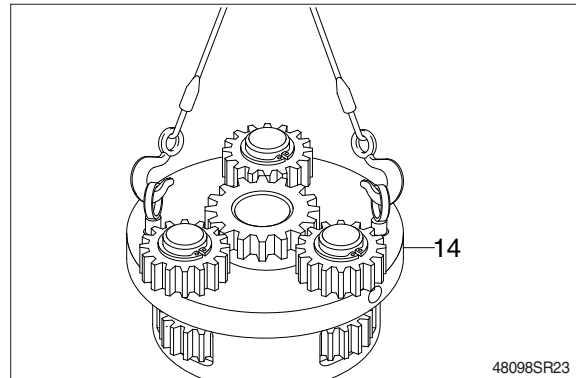

- (10) Apply loctite to the tapped holes of casing (1).

- (11) Tighten 3 M16 eye bolts to the ring gear (25) and lift up and then assemble it onto the casing (1).

- ※ Don't fail to coincide the knock pin (26) holes.

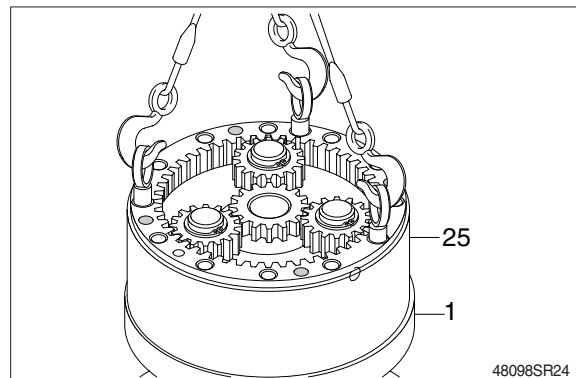

- (12) Hammer 4 knock pins (26) around the ring gear (25).

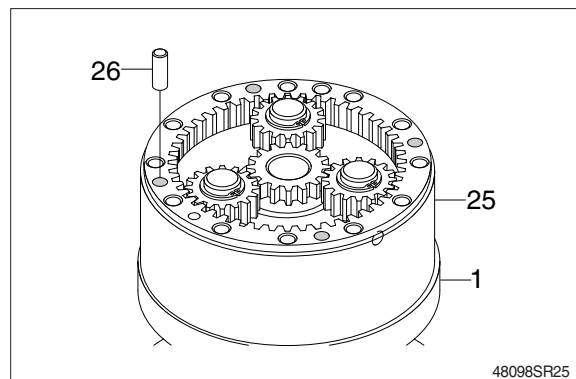

(13) Apply loctite to the tapped holes of the ring gear (25) and then mount swing motor onto the ring gear (25).

※ Don't fail to coincide the gauge bar (42) hole.

(14) Tighten socket bolts (36) around the swing motor assembly.

· Tightening torque : 24 kgf · m (173 lbf · ft)

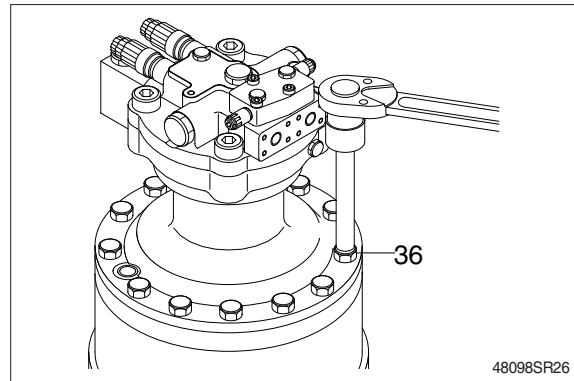

(15) Assemble plugs (37, 38).

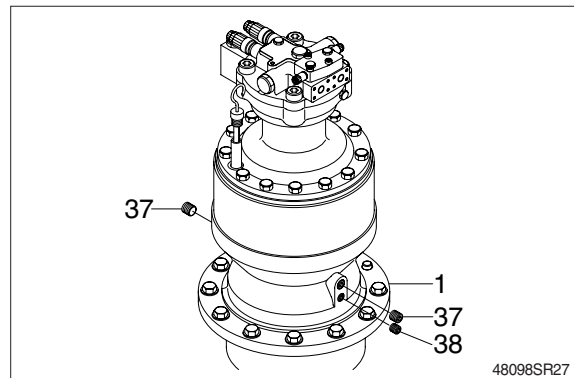

(16) Turn the swing motor assembly upside down and assemble cover plate (31) by tightening the hexagon bolts (32).

Install spacer (30) and pinion gear (29) to the drive shaft (2).

Assemble lock plate (33) on the pinion gear (29).

Assemble 2 lock washers (35) on the lock plate (33) with their 2 hole coincided individually to the tapped holes of drive shaft (2).

Tighten hexagon bolts (34) to the drive shaft (2) and then fold all the lock washer (35) corners over the hexagon bolts (34).

· Tightening torque : 24 kgf · m (173 lbf · ft)

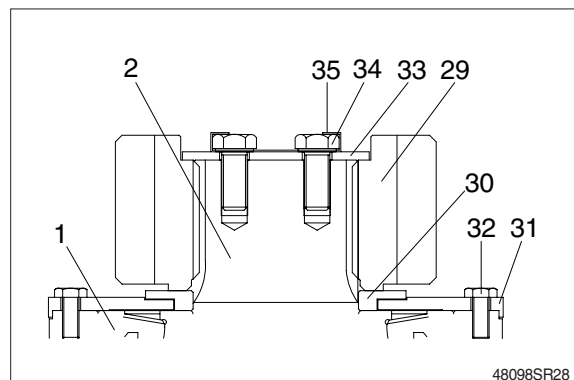

(17) Inject oil into the reduction gear.