

# GROUP 4 HYDRAULIC SYSTEM

## HYDRAULIC COMPONENTS MOUNTING 1

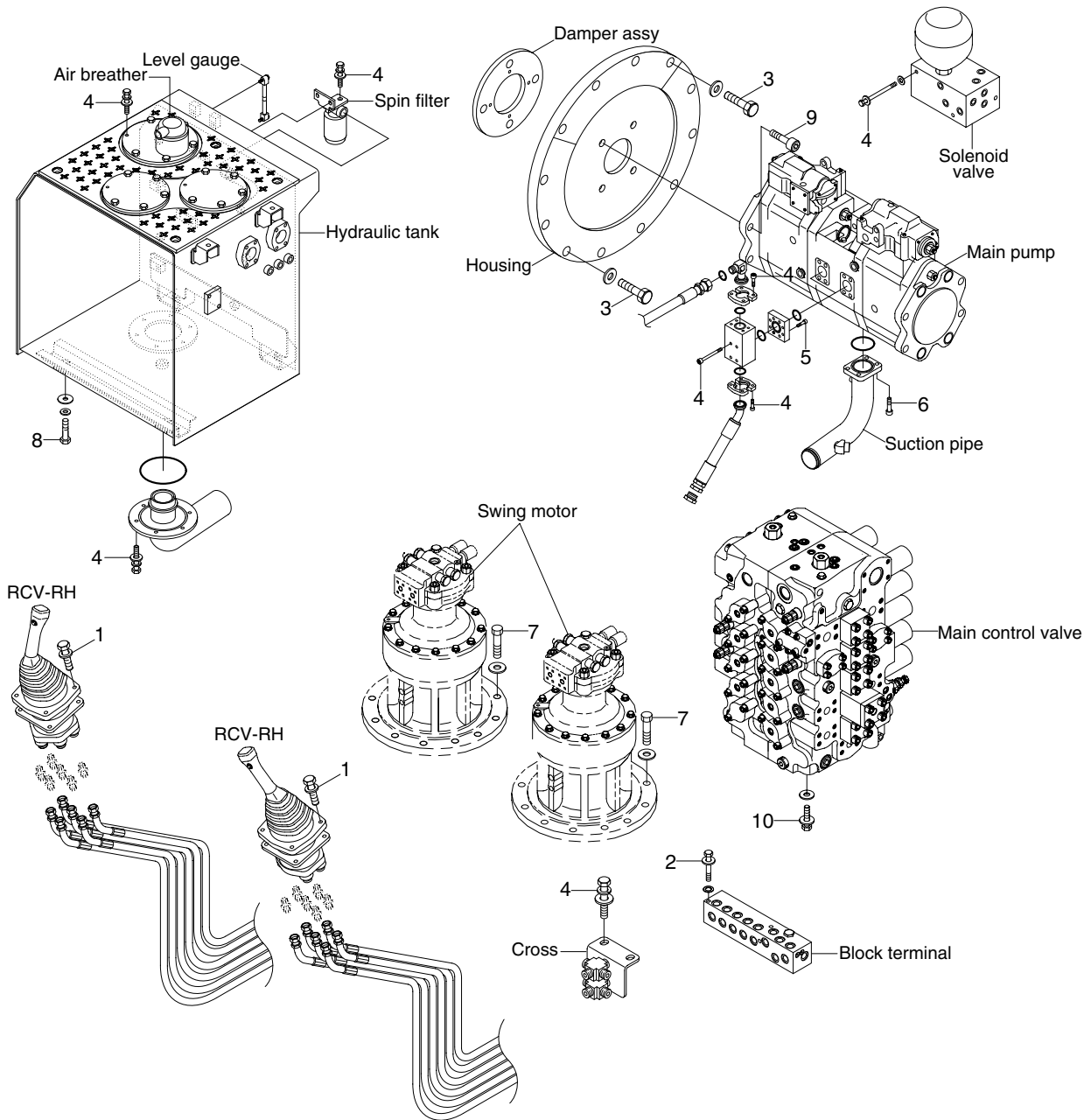

48099CM05

### · Tightening torque

Item	Size	kgf · m	lbf · ft
1	M 6×1.0	1.05±0.2	7.6±1.45
2	M 8×1.25	2.5±0.5	18.1±3.6
3	M10×1.5	4.8±0.3	34.7±2.2
4	M10×1.5	6.9±1.4	49.9±10.1
5	M12×1.75	12.3±1.3	88.2±9.4

Item	Size	kgf · m	lbf · ft
6	M16×2.0	29.7±4.4	215±31.8
7	M20×2.5	58.4±6.4	422±46.2
8	M20×2.5	46±5.1	333±36.9
9	M20×2.5	44±6.6	318±47.7
10	M20×2.5	57.9±8.7	419±62.9

## HYDRAULIC COMPONENTS MOUNTING 2

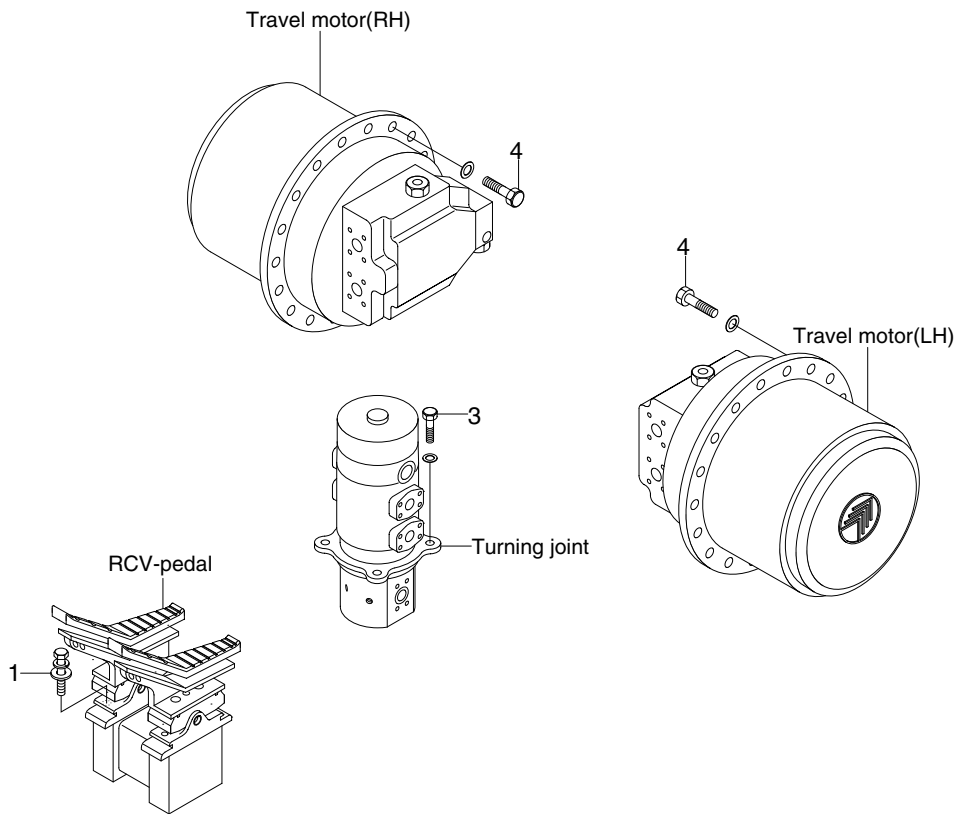

Boom safety lock system

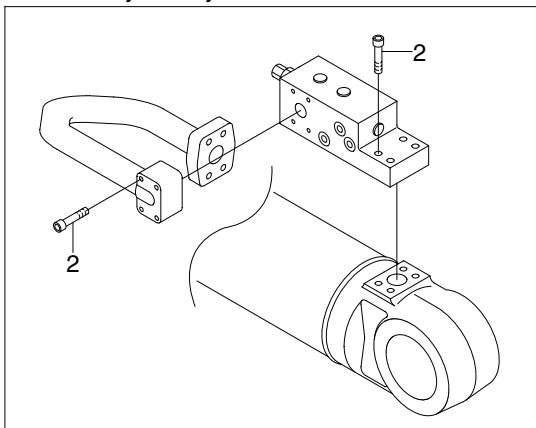

Arm safety lock system

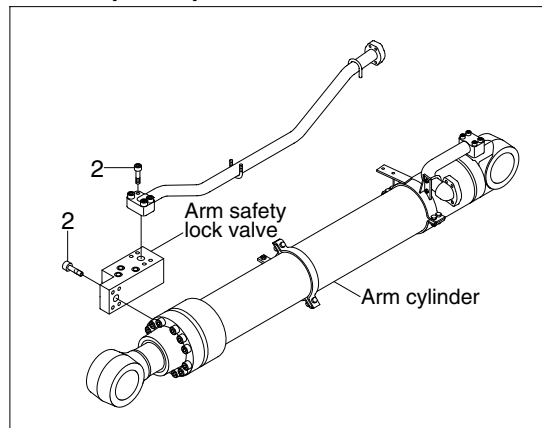

48099CM06

### · Tightening torque

Item	Size	kgf · m	lbf · ft
1	M10×1.5	6.9±1.4	49.9±10.1
2	M12×1.75	12.8±3.0	92.6±21.7

Item	Size	kgf · m	lbf · ft
3	M16×2.0	29.7±4.5	215±32.5
4	M20×2.5	57.9±8.7	419±62.9

# HYDRAULIC COMPONENTS MOUNTING 3

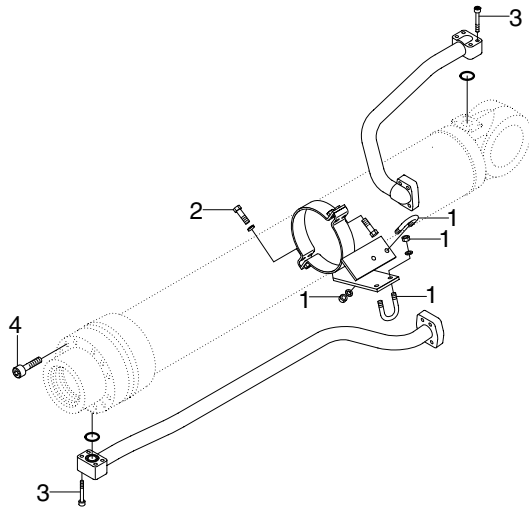

BOOM CYLINDER

## Solenoid valve

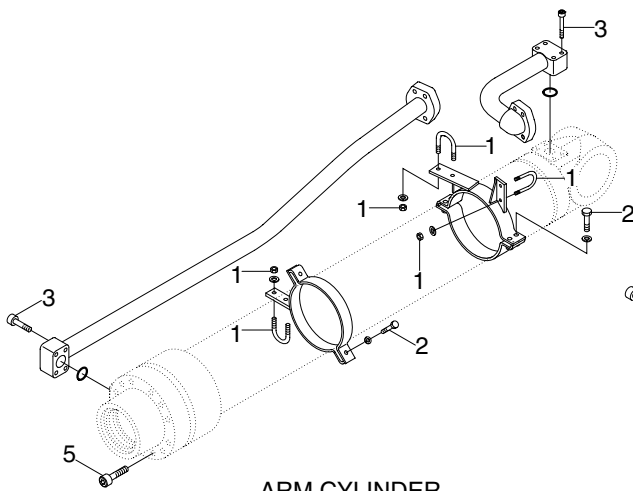
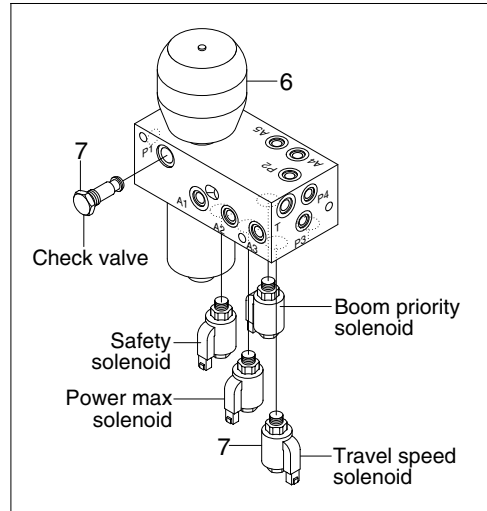

ARM CYLINDER

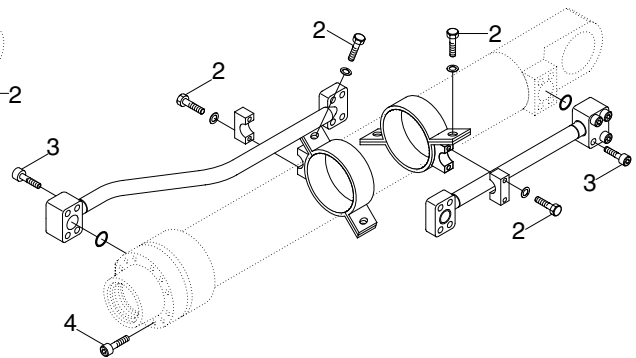

BUCKET CYLINDER

48099CM07

### · Tightening torque

Item	Size	kgf · m	lbf · ft
1	M10×1.5	3.2±0.3	23.1±2.2
2	M12×1.75	5.5±0.6	39.8±4.3
3	M12×1.75	9.4±1.0	68.0±7.2
4	M22×2.5	63±6.0	456±43.4

Item	Size	kgf · m	lbf · ft
5	M24×3.0	79±8.0	571±57.9
6	M22×2.5	4.1	29.6
7	M27×3.0	5.1	36.9