

## GROUP 5 SWING DEVICE

### 1. REMOVAL AND INSTALL OF MOTOR

#### 1) REMOVAL

- (1) Lower the work equipment to the ground and stop the engine.
- (2) Loosen the breather slowly to release the pressure inside the hydraulic tank.

**▲ Escaping fluid under pressure can penetrate the skin causing serious injury.**

※ When pipes and hoses are disconnected, the oil inside the piping will flow out, so catch it in oil pan.

- (3) Disconnect pipe assy(4, 5, 6, 7).
- (4) Disconnect pilot line hoses(2, 3, 8, 9, 10, 11, 12, 13, 14, 15, 16, 17).
- (5) Sling the swing motor assembly(1) and remove the swing motor mounting bolts(18).

- Motor device weight : 63kg(139lb)
- Tightening torque : 58.4kgf · m  
(422.4lbf · ft)

- (6) Remove the swing motor assembly.

※ When removing the swing motor assembly, check that all the piping have been disconnected.

#### 2) INSTALL

- (1) Carry out installation in the reverse order to removal.
- (2) Bleed the air from the swing motor.
  - ① Remove the air vent plug.
  - ② Pour in hydraulic oil until it over flows from the port.
  - ③ Tighten plug lightly.
  - ④ Start the engine, run at low idling, and check oil come out from plug.
  - ⑤ Tighten plug fully.
- (3) Confirmed the hydraulic oil level and check the hydraulic oil leak or not.

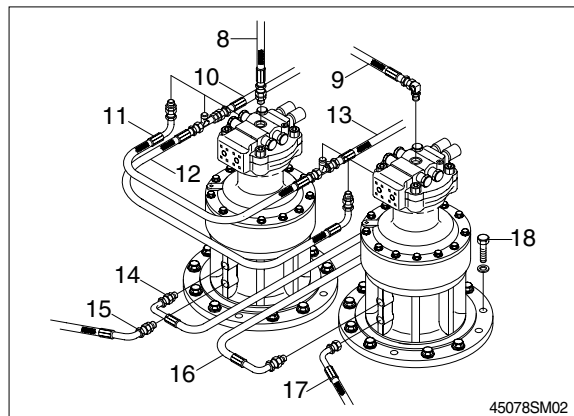
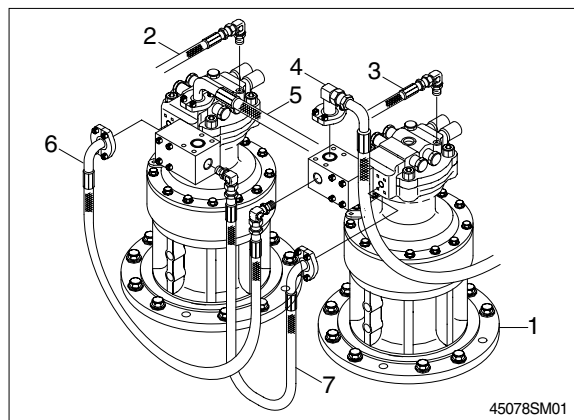

## 2. SWING MOTOR

### 1) STRUCTURE

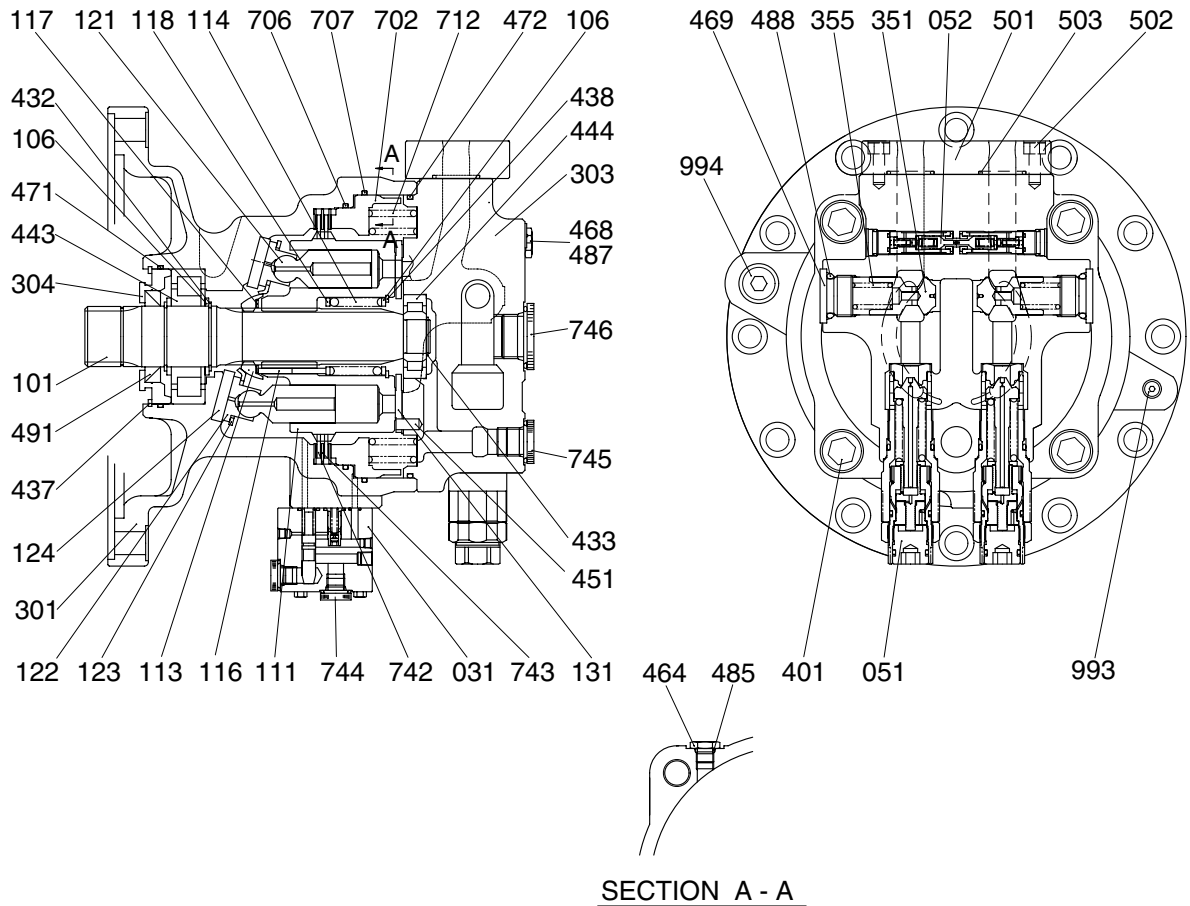

SECTION A - A

50072SM02

|                             |                     |                    |
|-----------------------------|---------------------|--------------------|
| 031 Brake valve             | 303 Valve casing(K) | 485 O-ring         |
| 051 Relief valve            | 304 Front cover     | 487 O-ring         |
| 052 Reactionless valve assy | 351 Plunger(K)      | 488 O-ring         |
| 101 Drive shaft             | 355 Spring          | 491 Oil seal       |
| 106 Spacer                  | 401 Socket bolt     | 501 Adapter        |
| 111 Cylinder block          | 432 Snap ring       | 502 Socket bolt    |
| 113 Spherical busing        | 433 Snap ring       | 503 O-ring         |
| 114 Cylinder spring         | 437 Snap ring       | 702 Brake piston   |
| 116 Push rod                | 438 Snap ring       | 706 O-ring         |
| 117 Spacer(F)               | 443 Roller bearing  | 707 O-ring         |
| 118 Spacer(R)               | 444 Roller bearing  | 712 Brake spring   |
| 121 Piston                  | 451 Spring pin      | 742 Friction plate |
| 122 Shoe plate              | 464 VP Plug         | 744 Dust plug      |
| 123 Retainer                | 468 VP Plug         | 745 Dust plug      |
| 124 Shoe                    | 469 RO Plug         | 746 Dust plug      |
| 131 Valve plate             | 471 O-ring          | 993 PT Plug        |
| 301 Casing(F)               | 472 O-ring          | 994 PT Plug        |

## 2) DISASSEMBLY

- (1) Lift the motor out. Clean the motor in kerosene and dry with compressed air.
  - ※ To avoid dust inside the motor, mask all the ports of the motor with tapes.

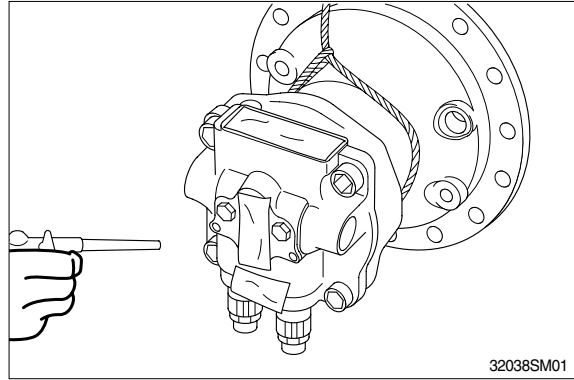

- (2) Loosen the drain plug to discharge oil in the casing(301).

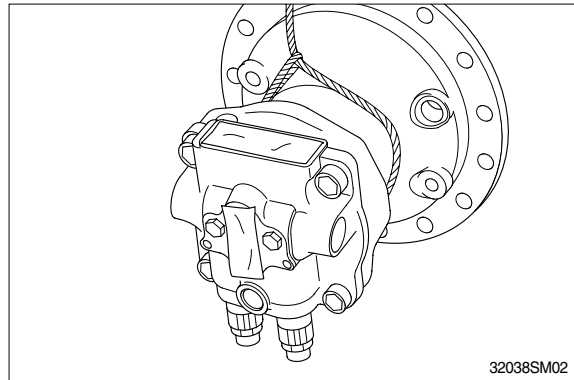

- (3) Fix the drive shaft(101) on the workbench with the end of output shaft down. Put matching marks on casing (301) and valve casing(303) for easy reassembly.

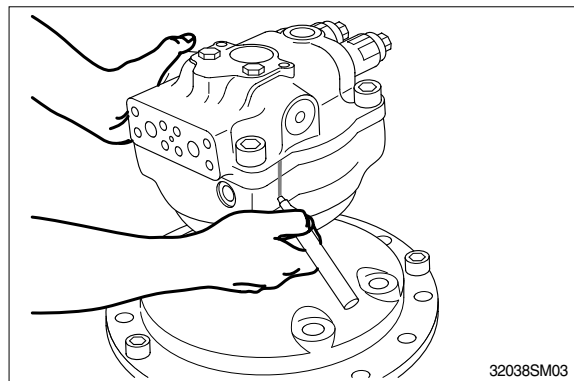

- (4) Remove the valve(052).

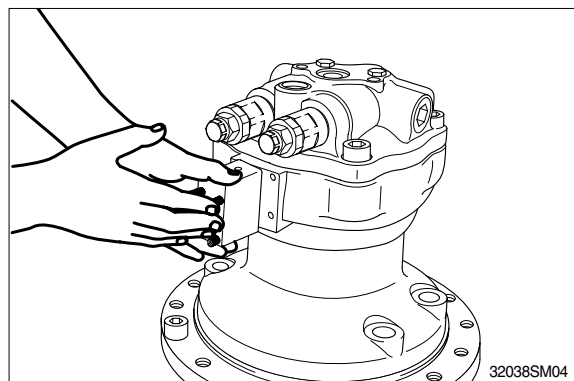

- (5) Remove the relief valve(051) from valve casing(303).

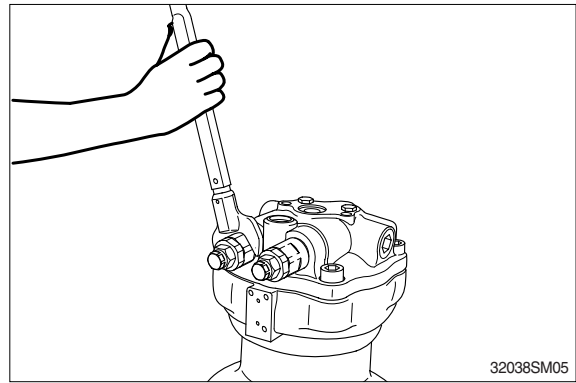

- (6) Remove plug(469) from valve casing (303) and spring(355), plunger(351).  
※ Be careful not to damage the plunger seat assembly.

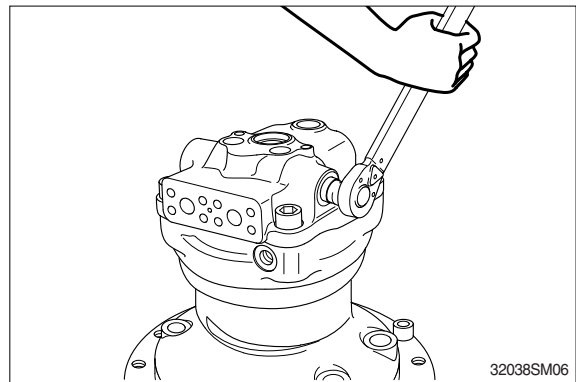

- (7) Remove valve casing(303) from casing (301). Then, remove the valve plate(131) from valve casing(303) with care.

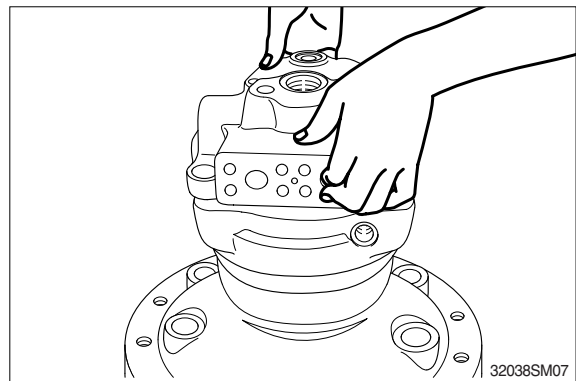

- (8) Remove the brake spring(712) from brake piston(702).

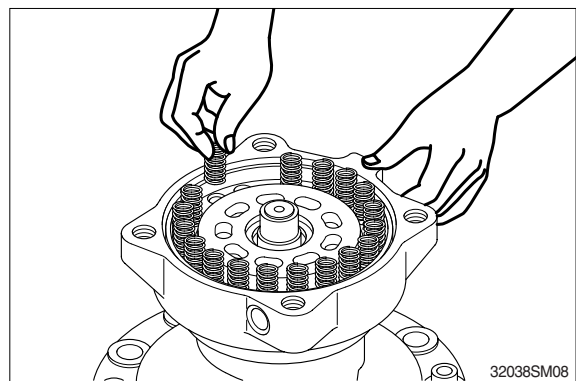

- (9) Remove brake piston(702) from casing (301).

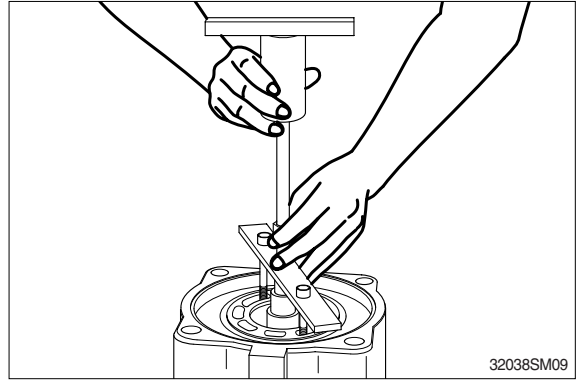

- (10) Remove the cylinder(111) from the output shaft (101) with the motor positioned horizontally. Remove piston(121), retainer(123), spherical bushing(113), spacer (117) and shoe plate(124).

※ If shoe plate would not removed easily, try again after procedure(14).

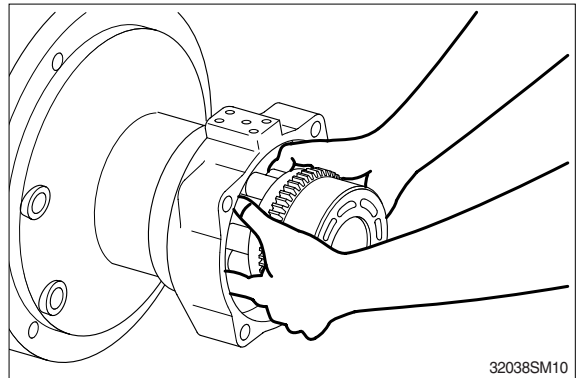

- (11) Remove friction plate(742) and separate plate(743) from casing(301).

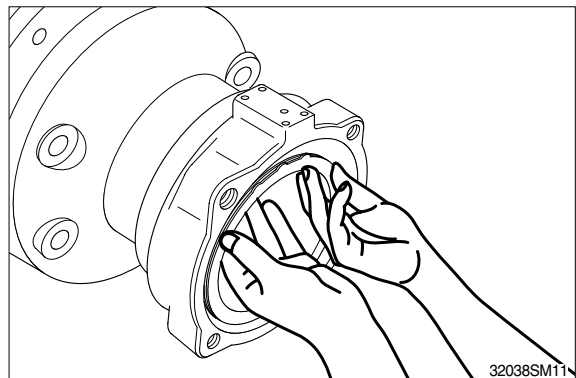

- (12) Remove snap ring(437) with plier and remove the front cover(304) from casing(301).

※ Front cover could be removed with sliding shaft if necessary.

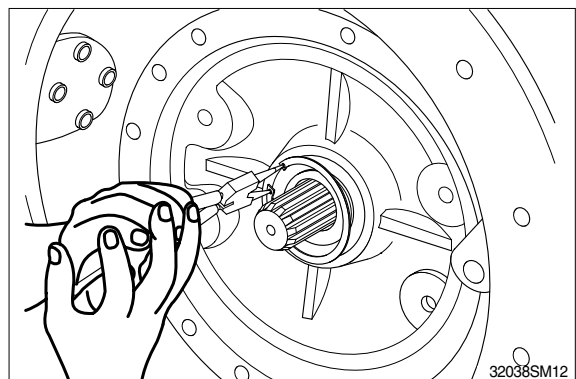

(13) Remove drive shaft(101) from casing (301).

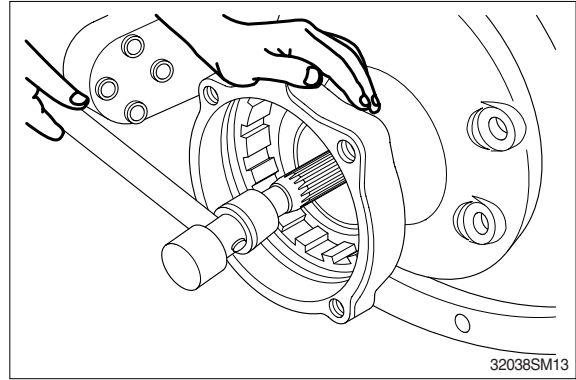

(14) Remove the shoe plate(124) from casing (301).

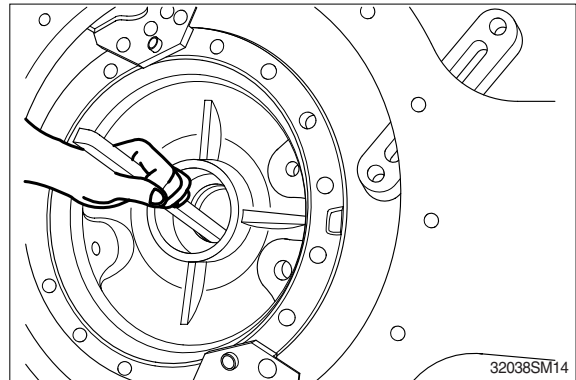

(15) Proceed with following job only when necessary.

- ① Remove the snap ring(432), spacer(106) from drive shaft(101) and remove the cone of roller bearing(443) by press.

※ Do not reuse bearings.

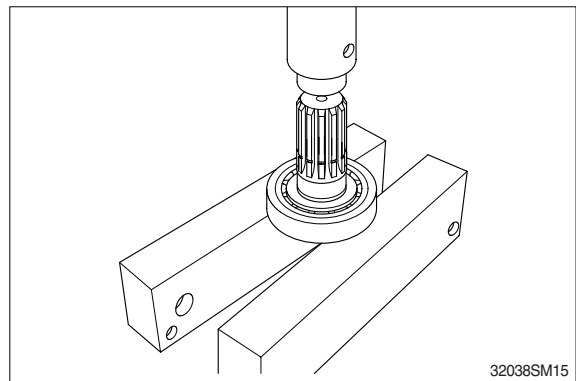
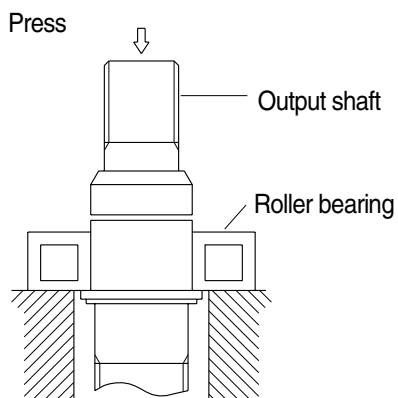

- ② Remove oil seal(491) from front cover (304).

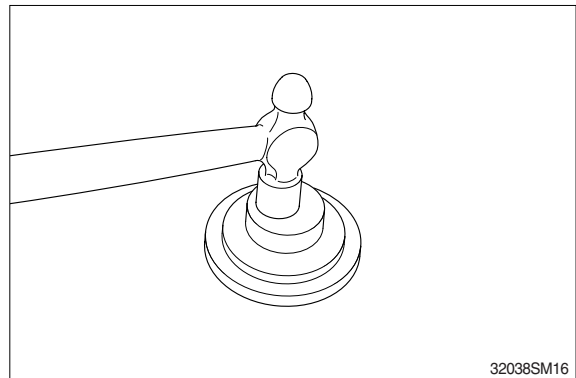

- ③ Remove the roller bearing(444) from the valve casing(303) by using slide hammer bearing puller.

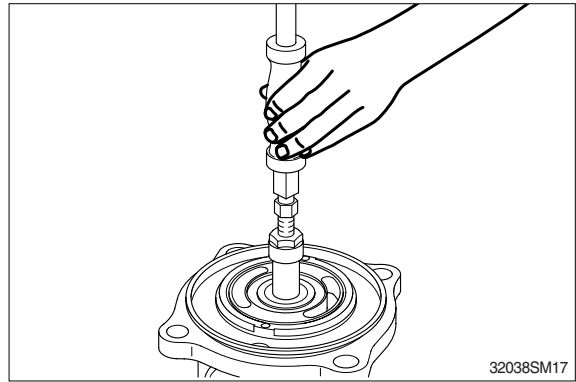

- ④ When disassembling the relief valve, release the plug(3).  
Remove the piston(7), spring seat(9), spring(8) and plunger(6) with the body(1) downwards.

※ Do not release the lock nut(15).

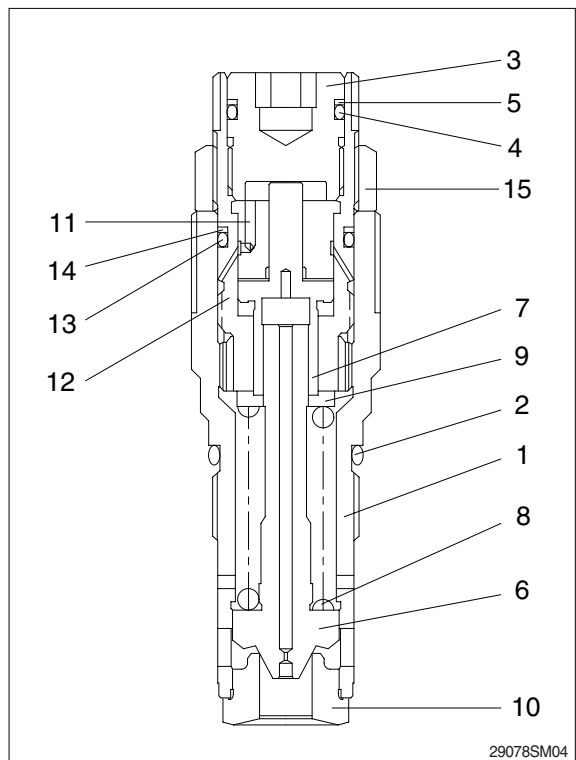

This completes disassembly.

### 3) ASSEMBLY

Do the reassembly in the reverse procedure of the disassembly.

- (1) Place the casing(301) on the workbench with the valve casing(303) downward.

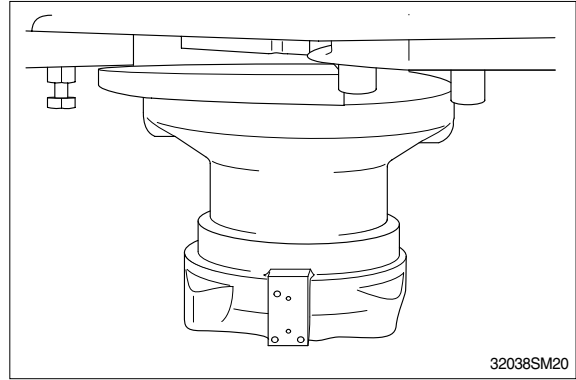

- (2) When reassembling the roller bearing, install the snap ring(432), and spacer(106) to the drive shaft(101). Insert the collar and cone of the roller bearing(443). Install the spacer(106) and snap ring(432). Install snap ring(433) to the output shaft (101) by heating the cone of the roller bearing(444).

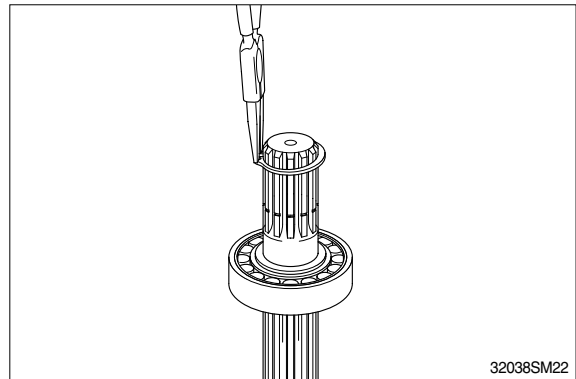
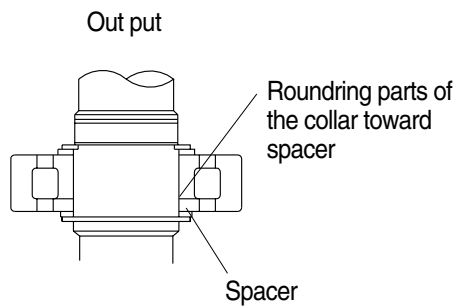
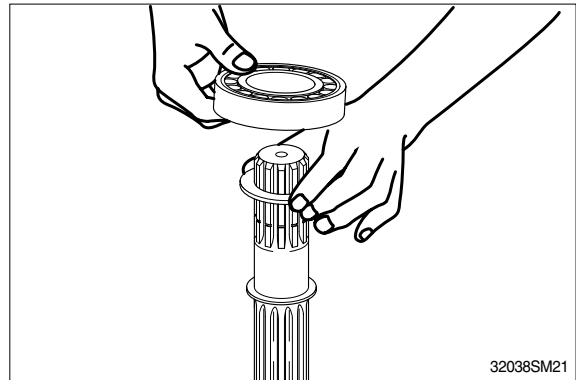

- (3) Insert the drive shaft(101) into the casing (301) with the end of output shaft upward and tap the outer race of roller bearing with the hammer.

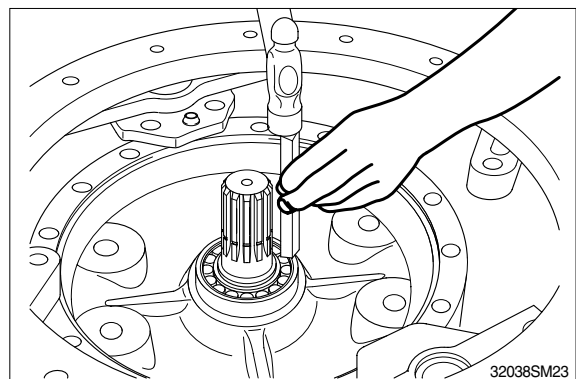



(4) Tack O-ring(471) to the casing(301).

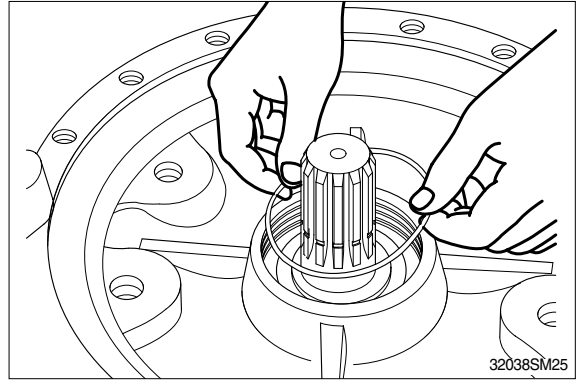

(5) Reassemble the front cover(304) to the casing(301).  
※ Apply grease to the rib of oil seal to avoid damage to the rib.

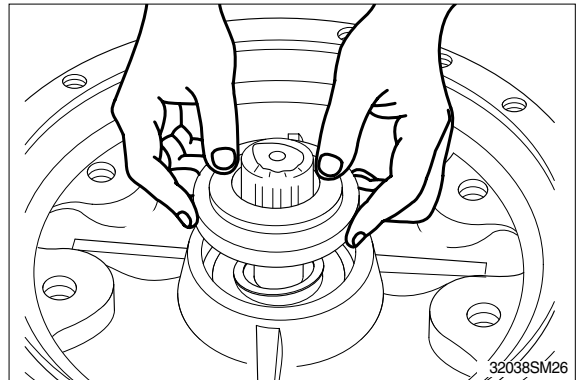

(6) Install the snap ring(437) to the casing (301).

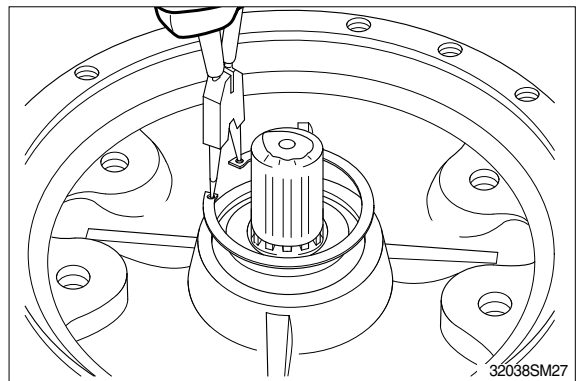

(7) Insert the shoe plate(124) with the casing (301) position horizontally.

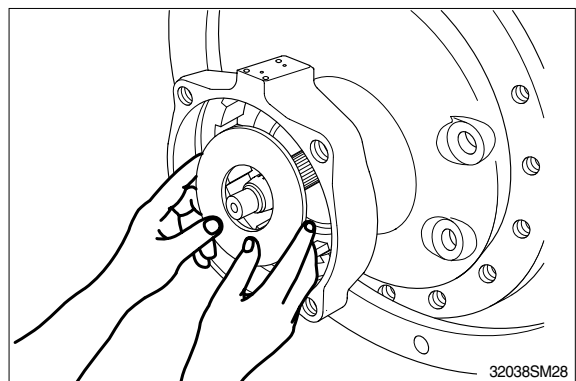

(8) Insert the push rod(116) into the cylinder (111). Place the spherical bushing(113) assembled with spacer(117) onto the cylinder.

※ Insert two push rods in each hole.

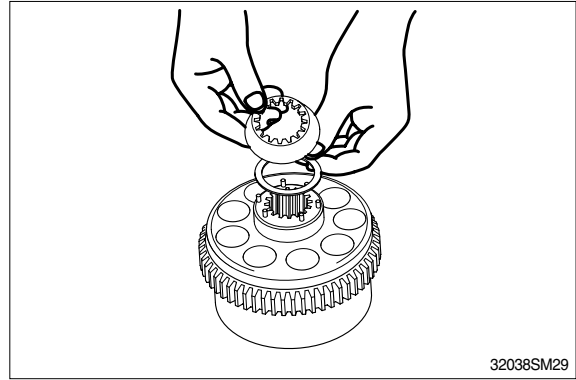

(9) Install the piston sub-assembly(121, 122) to the retainer(123).



(10) Reassemble the piston assembly(121, 122) to the cylinder(111).

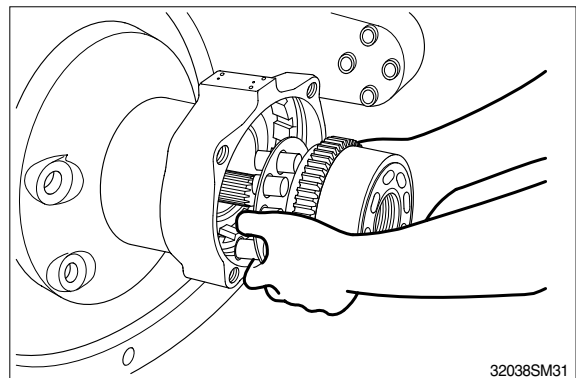

(11) Place the casing(301) under the front cover(304) and reassemble 3 sheets of separate plate(743) and then 2 sheets of friction plate(742) to the casing(301).

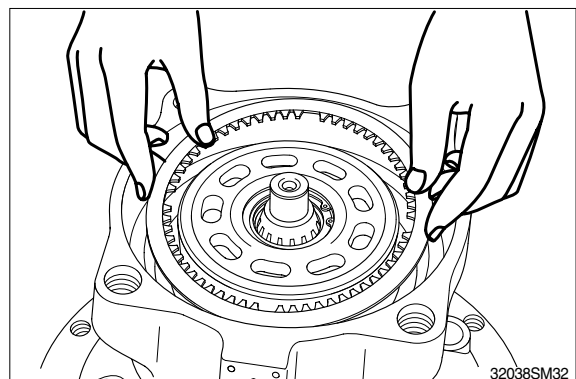

(12) Insert O-ring(706, 707) inside the casing (301).

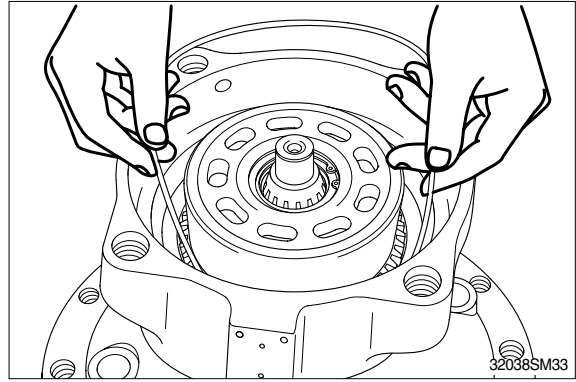

(13) Reassemble brake piston(702) to the casing(301).

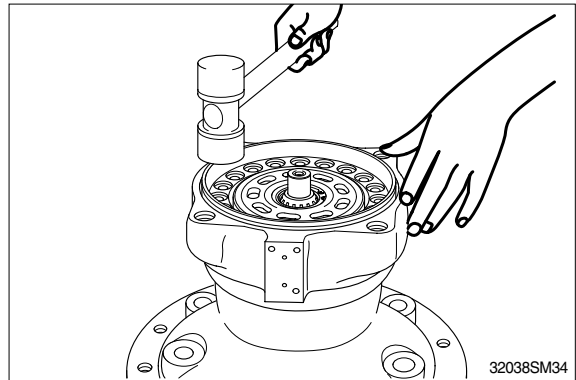

(14) Reassemble brake spring(712) to the brake piston(702).

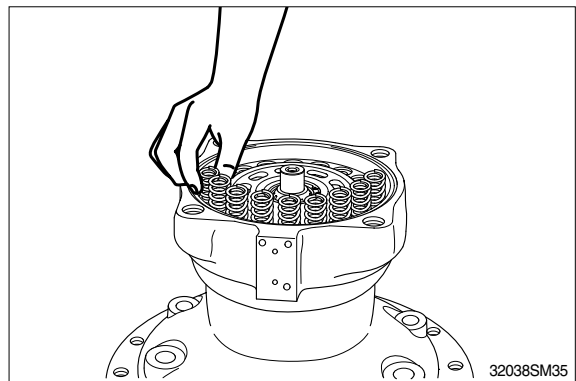

(15) When assembling the roller bearing(444), insert the roller bearing(444) into valve casing(303) by hammering.

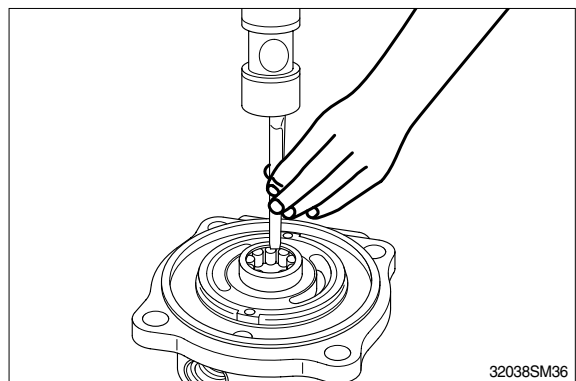

(16) Reassemble valve plate(131) to the valve casing(303) and reassemble O-ring(472).

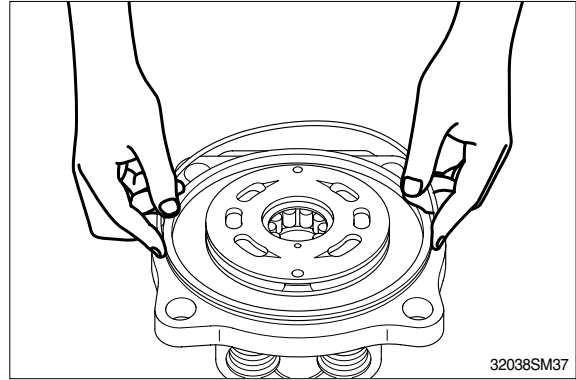

(17) Connect the valve casing(303) with the casing(301) and tighten the hexagon socket bolt(401).

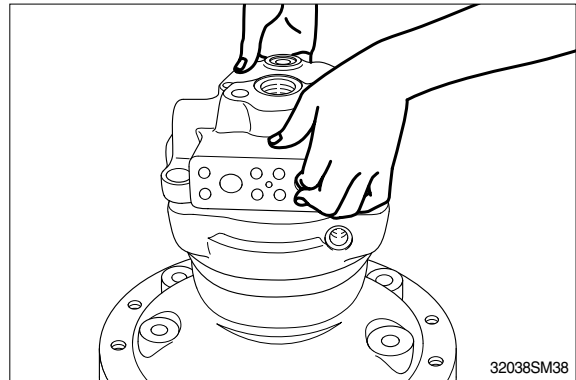

(18) Insert plunger(351) and spring(355) in the valve casing and install O-ring(488). Tighten plug(469) to the valve casing.

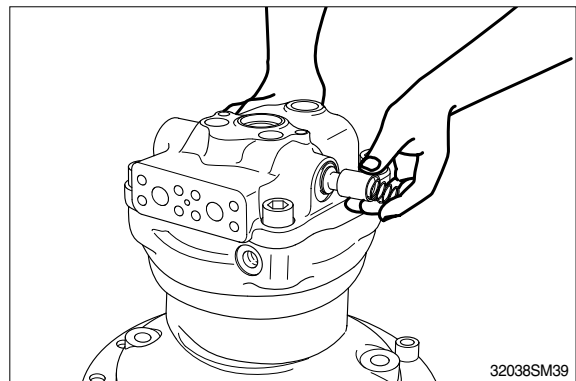

(19) Insert O-rings(051-1) to the relief valve (051) and reassemble them to valve casing(303).

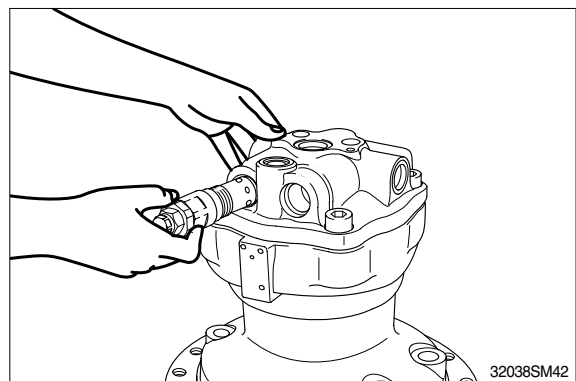

(20) Tighten the plug(468) to valve casing(303) with O-ring(487) and tighten the plug(464) to casing(301) with O-ring(485).

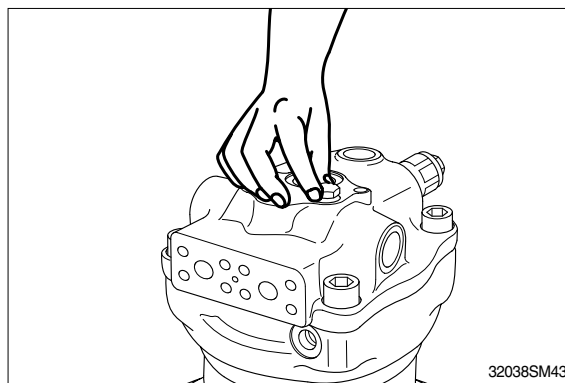

(21) Connect the valve casing(303) with the casing(301).

This completes assembly.

### 3. REMOVAL AND INSTALL OF REDUCTION GEAR

#### 1) REMOVAL

- (1) Remove the swing motor assembly.  
For details, see **removal of swing motor assembly**.
- (2) Sling reduction gear assembly(1) and remove mounting bolts(2).
- (3) Remove the reduction gear assembly.
  - Reduction gear device weight : 180kg  
(396lb)



#### 2) INSTALL

- (1) Carry out installation in the reverse order to removal.
  - Tightening torque : 49.2~66.6kgf · m  
(356~481lbf · ft)

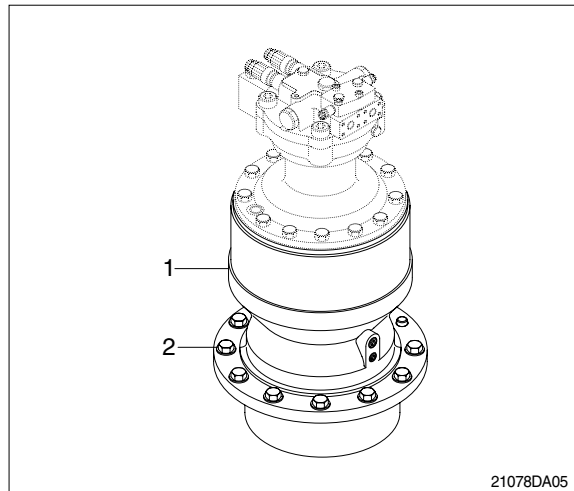

## 4. REDUCTION GEAR

### 1) STRUCTURE

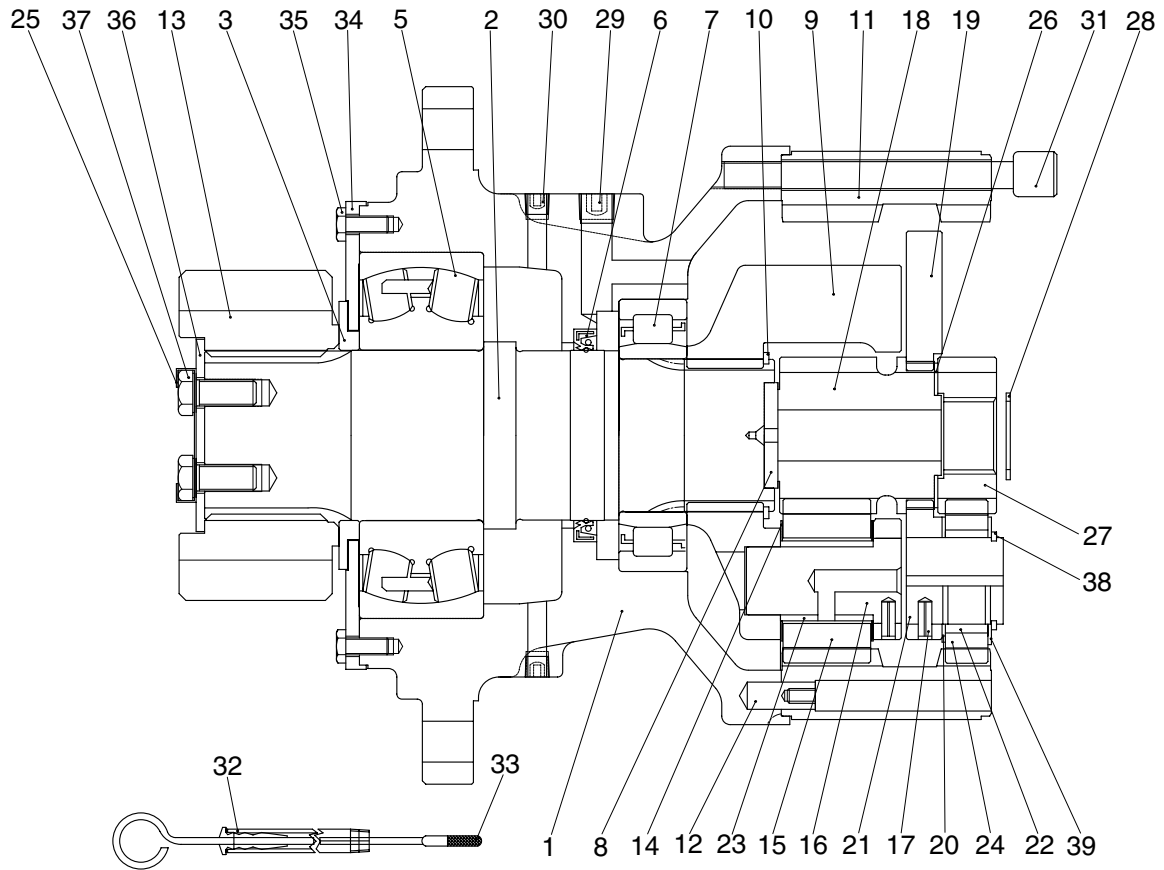

50072SM03

|    |                |    |               |    |                      |
|----|----------------|----|---------------|----|----------------------|
| 1  | Casing         | 15 | Planet gear 2 | 28 | Stop ring            |
| 2  | Drive shaft    | 16 | Pin 2         | 29 | Plug                 |
| 3  | Spacer         | 17 | Spring pin    | 30 | Plug                 |
| 5  | Roller bearing | 18 | Sun gear 2    | 31 | Socket bolt          |
| 6  | Oil seal       | 19 | Carrier 1     | 32 | Gage pipe 39         |
| 7  | Roller bearing | 20 | Side plate 1  | 33 | Gage bar side plate2 |
| 8  | Thrust plate   | 21 | Pin 1         | 34 | Cover plate          |
| 9  | Carrier 2      | 22 | Needle cage   | 35 | Hex bolt             |
| 10 | Stop ring      | 23 | Bushing       | 36 | Lock plate           |
| 11 | Ring gear      | 24 | Planet gear 1 | 37 | Hex bolt             |
| 12 | Knock pin      | 25 | Lock washer   | 38 | Stop ring            |
| 13 | Pinion gear    | 26 | Side plate 3  | 39 | Side plate 2         |
| 14 | Thrust washer  | 27 | Sun gear 1    | 40 | Air breather assy    |

## 2) DISASSEMBLY

(1) Spread off the 4 corners of lock washer (25) with a tool.

※ Do not reuse lock washer(25).

Loosen the hexagon bolts(37) and then remove lock washer(25) and lock plate (36) from the pinion gear(13).

Remove pinion gear(13) and spacer(3) from the drive shaft(2).

Remove cover plate(34) from the casing (1) by loosening the hexagon socket bolts (35).

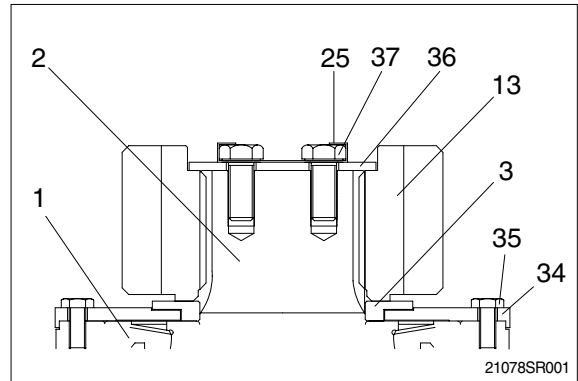

(2) Remove gauge bar(33) and gauge pipe (32) from the swing motor casing.

※ Pour the gear oil out of reduction gear into the clean bowl to check out the friction decrease.

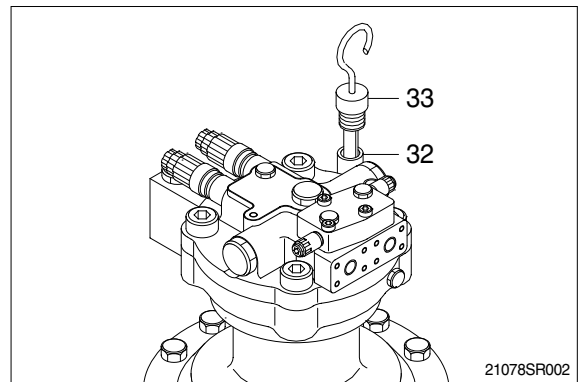

(3) Loosen the socket bolts(31) to separate swing motor from reduction gear.

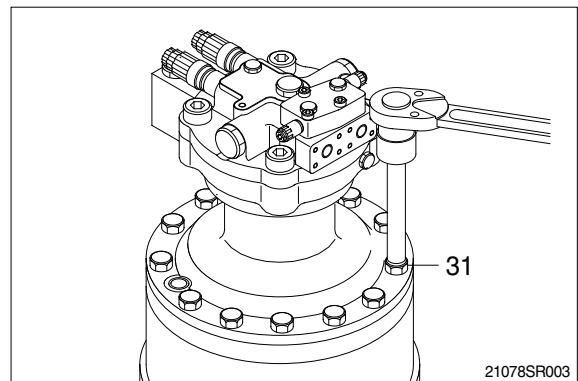

(4) Tighten 3 M16 eye bolts to the ring gear (11) and then lift the ring gear(11) out of the casing(1).

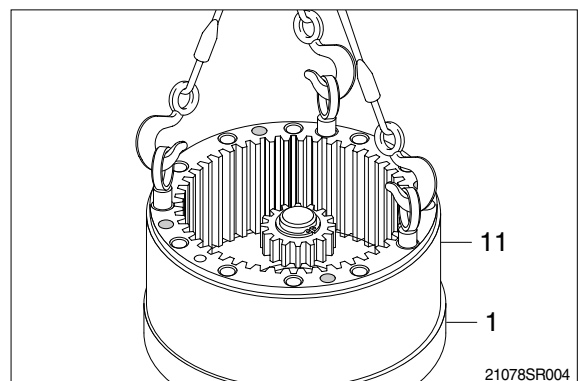



- (5) Remove stop ring(28) and then sun gear1 (27).

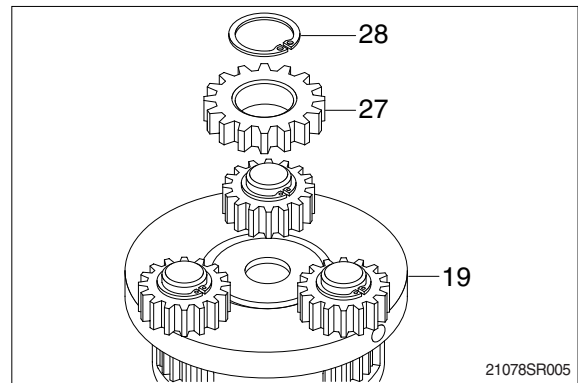

- (6) Tighten two M10 eye bolts to carrier1(19) and lift up and remove carrier1(19) as subassembly.

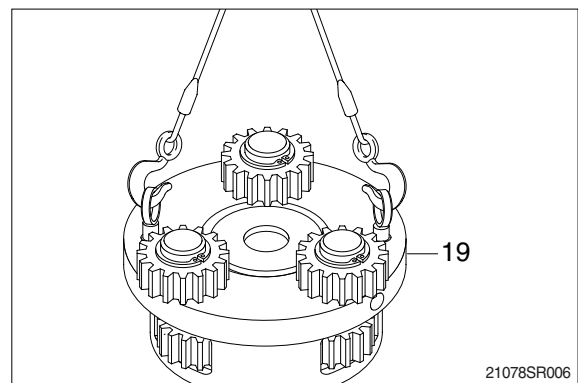

- (7) Disassembling carrier1(19) assembly.

- ① Remove stop ring(38).
- ② Remove side plate2(39), planet gear1 (24), needle cage(22), side plate1(20) and side plate3(26) from the carrier.
- ③ Using M8 solid drill, crush spring pin(17) so that the pin1(21) can be removed by hammering.
- ④ Remove side plate3(26) from carrier1(19).
  - ※ Do not reuse spring pin(17).
  - ※ Do not remove pin1(21), carrier1(19) and spring pin(17) but in case of replacement.
  - ※ Put matching marks on the planet gear1 (24) and the pin1(21) for easy reassembly.

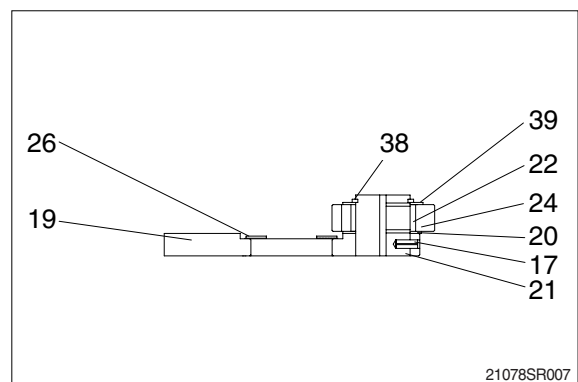

(8) Remove sun gear2(18) and thrust gear (14).

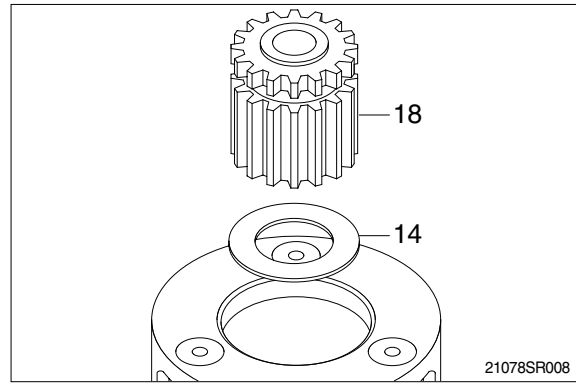

(9) Remove carrier2(9) assembly from casing (1).

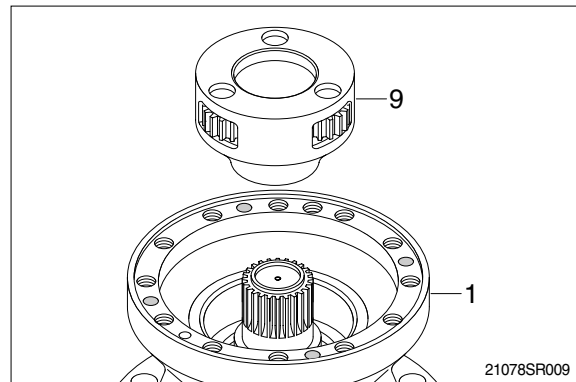

(10) Disassembling carrier2(9) assembly

- ① Using M8 solid drill, crush spring pin(17) so that the pin2(16) can be removed.
- ※ Do not reuse spring pin(17).
- ② Remove pin2(16), planet gear2(15) and bush2(23) from the carrier2(9).
- ※ Put matching marks on the planet gear2 (15) and the pin2(16) for easy reassembly.
- ※ Do not disassemble pin2(16), carrier2(9) and spring pin(17) but in case of replacement.

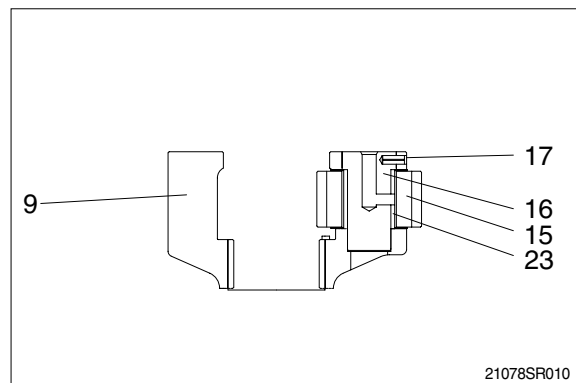

(11) Remove thrust plate3(8) and stop ring (10) from the drive shaft(2).

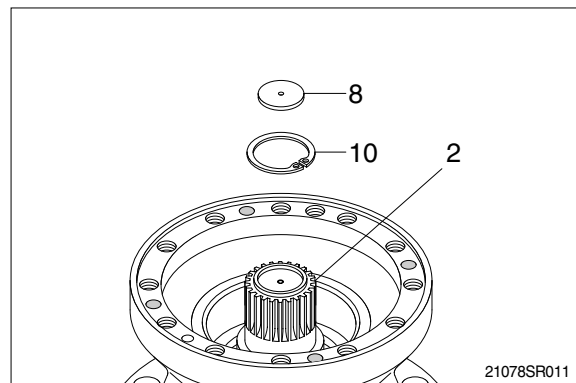

- (12) Remove drive shaft(2) with roller bearing(7) and oil seal(6) assembled.  
Remove knock pin(12) from the casing(1).

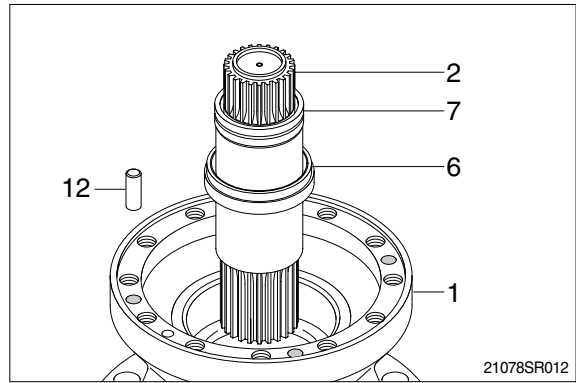

- (13) Remove roller bearing(7) and oil seal(6)  
from the drive shaft(2).  
※ Do not reuse oil seal(6) once removed.

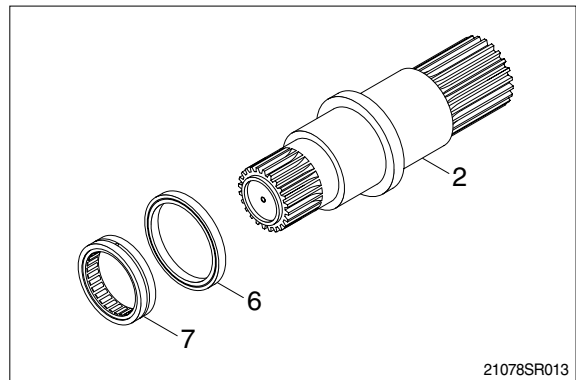

- (14) Using the bearing disassembly tool,  
remove roller bearing(5).

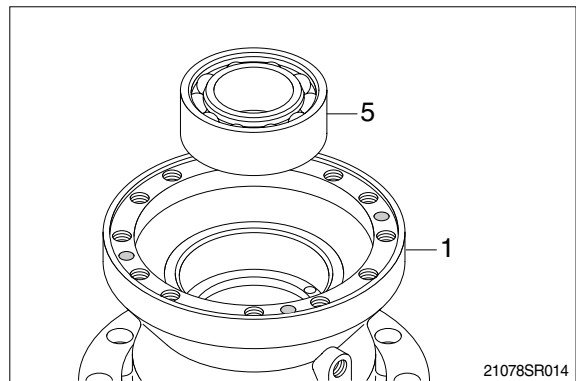

- (15) Remove plugs(29, 30) from the casing(1).

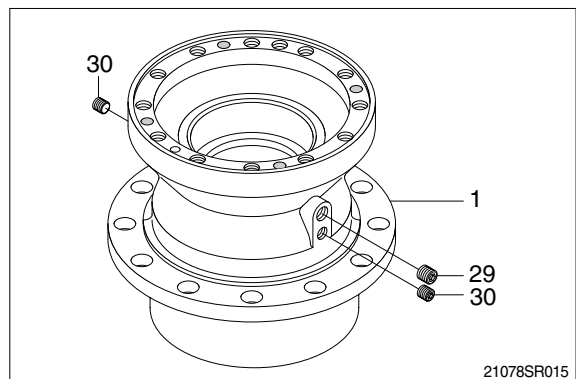

### 3) ASSEMBLY

- (1) Assemble roller bearing(5) inside the casing(1).

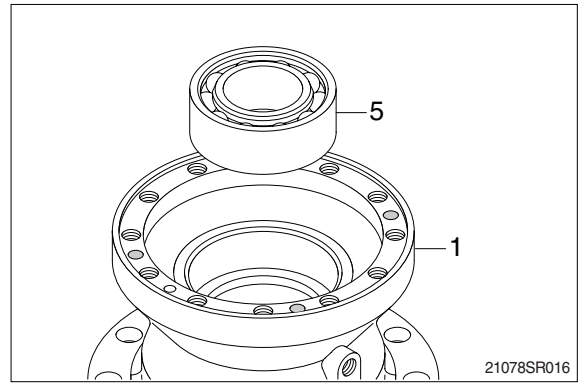

- (2) Assemble the drive shaft(2) into the casing(1) and then install oil seal(6) and roller bearing(7).

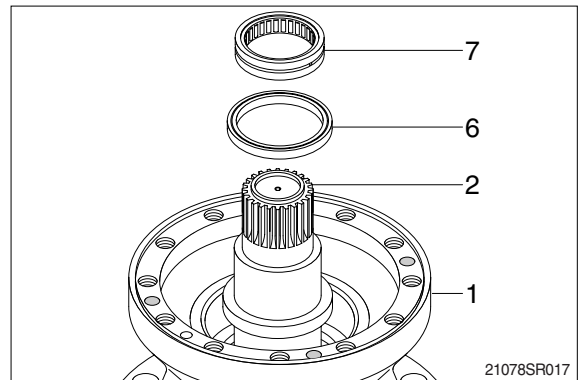

- (3) Install stop ring(10) and thrust plate 3(8) on top of drive shaft(2).

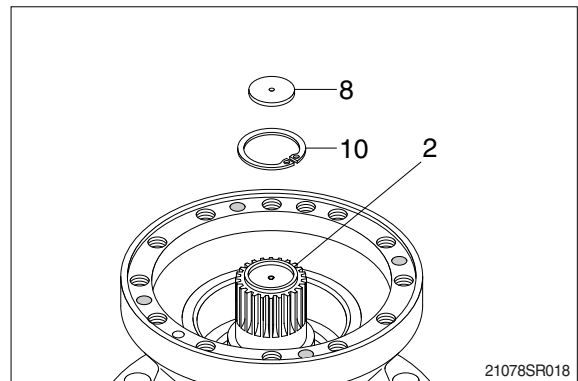

- (4) Assembling carrier2(9) assembly.

- ① Install thrust washer(14) inside the carrier2 (9).
  - ② Install bush2(23) inside the planet gear2 (15) and then assemble them to the carrier2(9).
  - ③ Assemble the pin2(16) to the carrier2(9) and then press the spring pin(17) by hammering.
  - ④ Punch 2 points of the spring pin(17) lip.
- ※ Take care not to mistake the matching marks of each part.

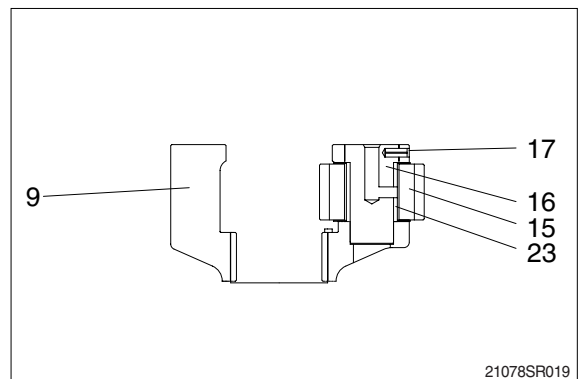

- (5) Assemble carrier2(9) assembly correctly to the drive shaft(2).

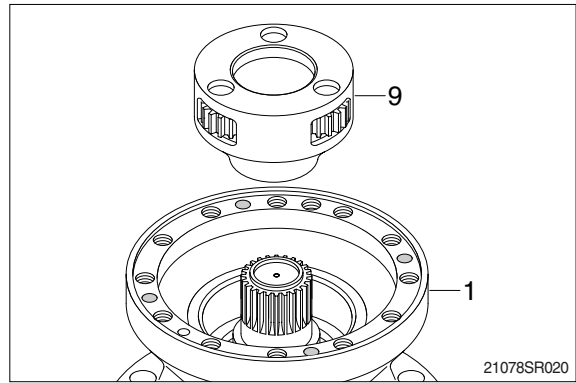

- (6) Assemble sun gear2(18) and thrust washer(14) to the center of the carrier2(9) assembly.

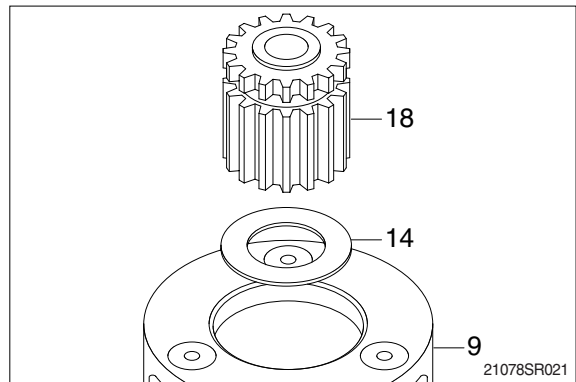

- (7) Assembling carrier1(19) assembly.

- ① Assemble the pin1(21) to the carrier1(19) and then press the spring pin(17) by hammering.
  - ② Punch 2 points of the spring pin's(17) lip.
  - ③ Install side plate3(26) onto the center of carrier1(19).
  - ④ Install needle cage(22) into the planet gear1(24).
  - ⑤ Assemble side plate(20), planet gear1(24), side plate2(39) and then stop ring(38) to the pin1(21).
- ※ Take care not to mistake the matching marks of each part.

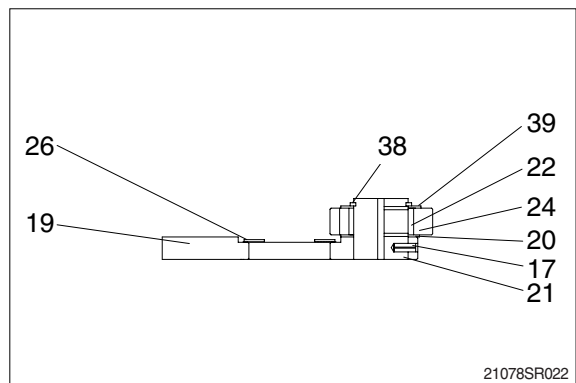

(8) Install sun gear(27) onto the side plate3 (26).

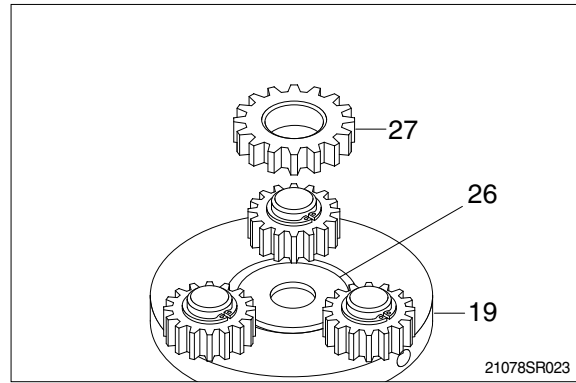

(9) Assemble carrier1(19) assembly onto the carrier2(9) assembly.

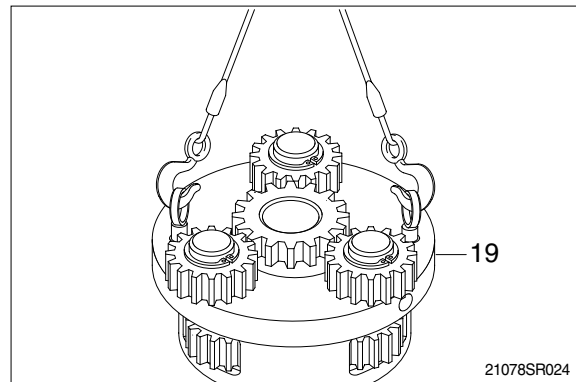

(10) Apply loctite to the tapped holes of casing (1).

(11) Tighten 3 M16 eye bolts to the ring gear(11) and lift up and then assemble it onto the casing(1).

※ Don't fail to coincide the knock pin(12) holes.

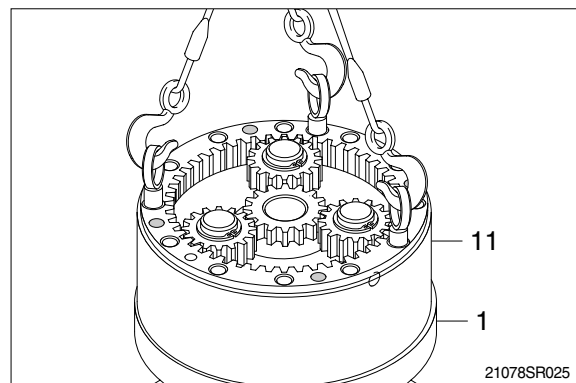

(12) Hammer 4 knock pins(12) around the ring gear(11).

(13) Assemble stop ring(28) to the drive shaft of the swing motor.

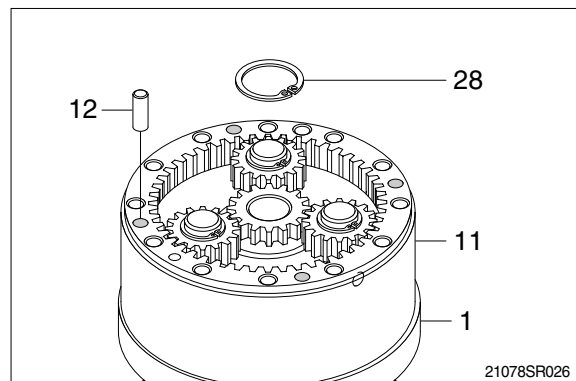

(14) Apply loctite to the tapped holes of the ring gear(11) and then mount swing motor onto the ring gear(11).

※ Don't fail to coincide the gauge bar(33) hole.

(15) Tighten socket bolts(31) around the swing motor assembly.

· Tightening torque :  $25 \pm 2.5 \text{kgf} \cdot \text{m}$   
( $181 \pm 18 \text{lbf} \cdot \text{ft}$ )

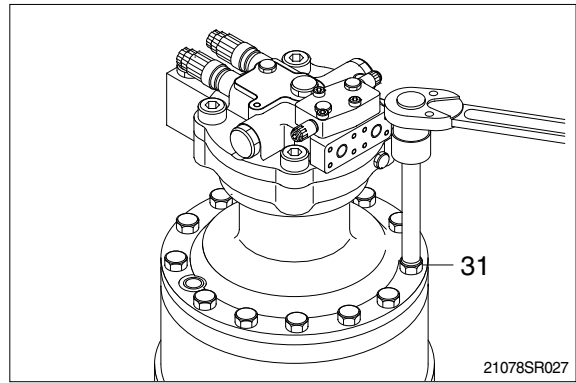

(16) Assemble plugs(29, 30), gauge bar(33) and gauge pipe(32).

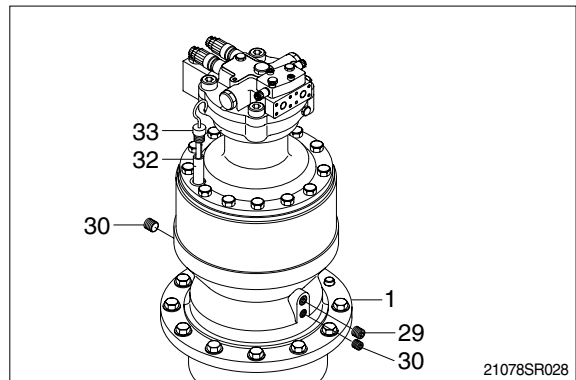

(17) Turn the swing motor assembly upside down and assemble cover plate(34) by tightening the hexagon socket bolts(35). Install spacer(3) and pinion gear(13) to the drive shaft(2).

Assemble lock plate(36) on the pinion gear(13).

Assemble 2 lock washers(25) on the lock plate(36) with their 2 hole coincided individually to the tapped holes of drive shaft(2).

Tighten hexagon socket bolts(37) to the drive shaft(2) and then fold all the lock washer(25) corners over the hexagon bolts(37).

· Tightening torque :  $25 \pm 2.5 \text{kgf} \cdot \text{m}$   
( $181 \pm 18 \text{lbf} \cdot \text{ft}$ )

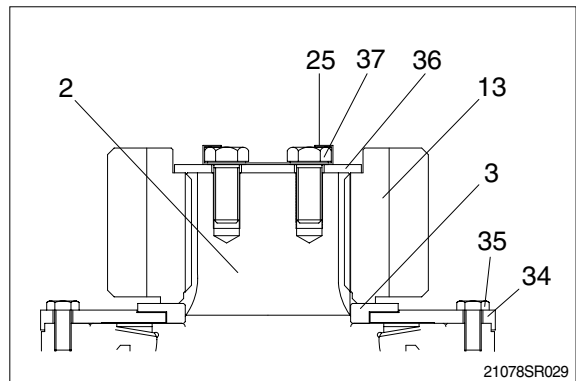

(18) Inject oil into the reduction gear.