

GROUP 4 SINGLE OPERATION

1. BOOM UP OPERATION

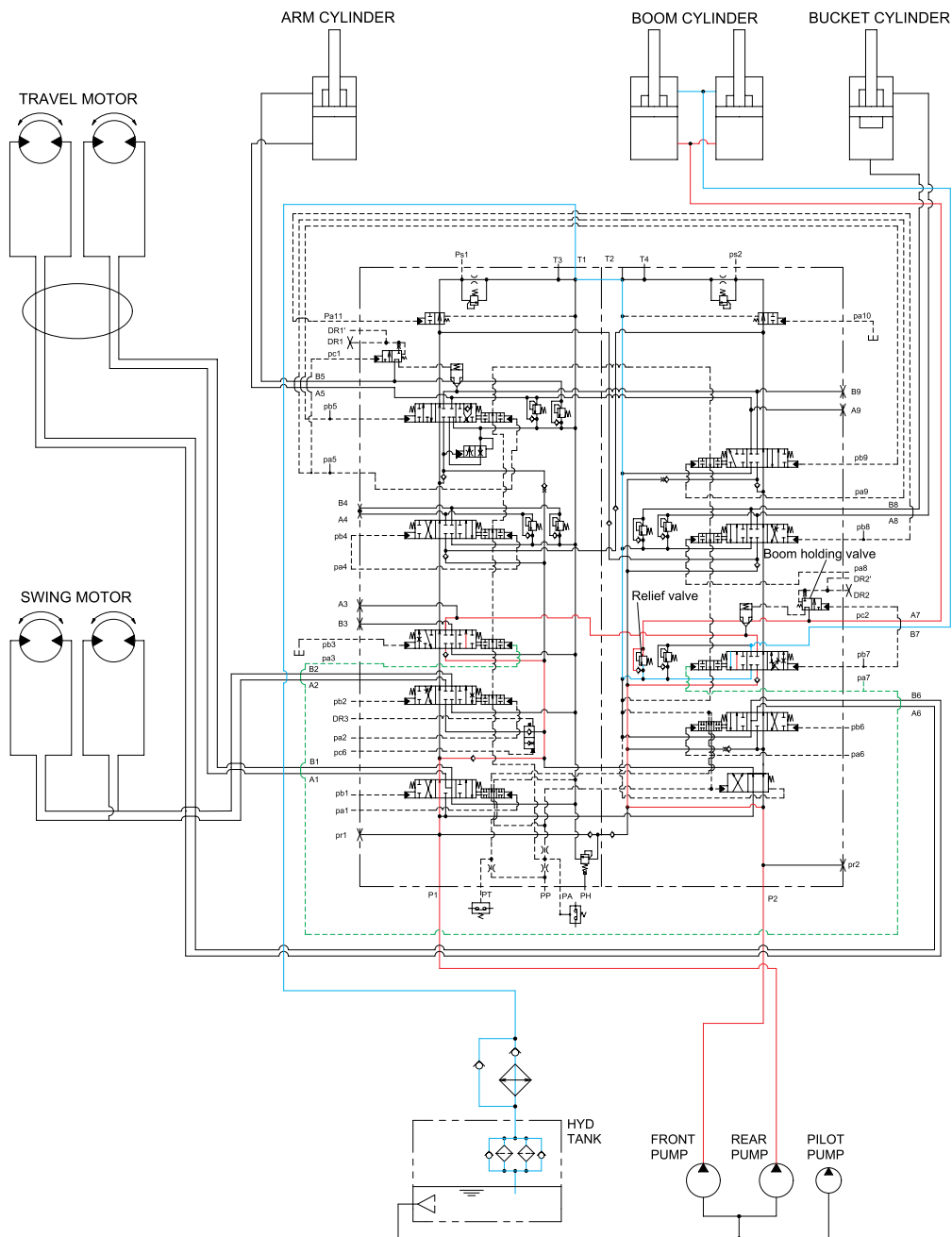

45073HC09

When the RH control lever is pulled back, the boom spools in the main control valve are moved to the up position by the pilot oil pressure from the remote control valve.

The oil from the front and rear pump flows the main control valve and then goes to the large chamber of boom cylinders via logic valve.

At the same time, the oil from the small chamber of boom cylinders returns to the hydraulic oil tank through the boom spool in the main control valve. When this happens, the boom goes up.

The excessive pressure in the boom cylinder bottom end circuit is prevented by relief valve.

When the boom is up and the control lever is returned to neutral position, the circuit for the holding pressure at the bottom end of the boom cylinder is closed by the boom holding valve.

This prevents the hydraulic drift of boom cylinders.

2. BOOM DOWN OPERATION

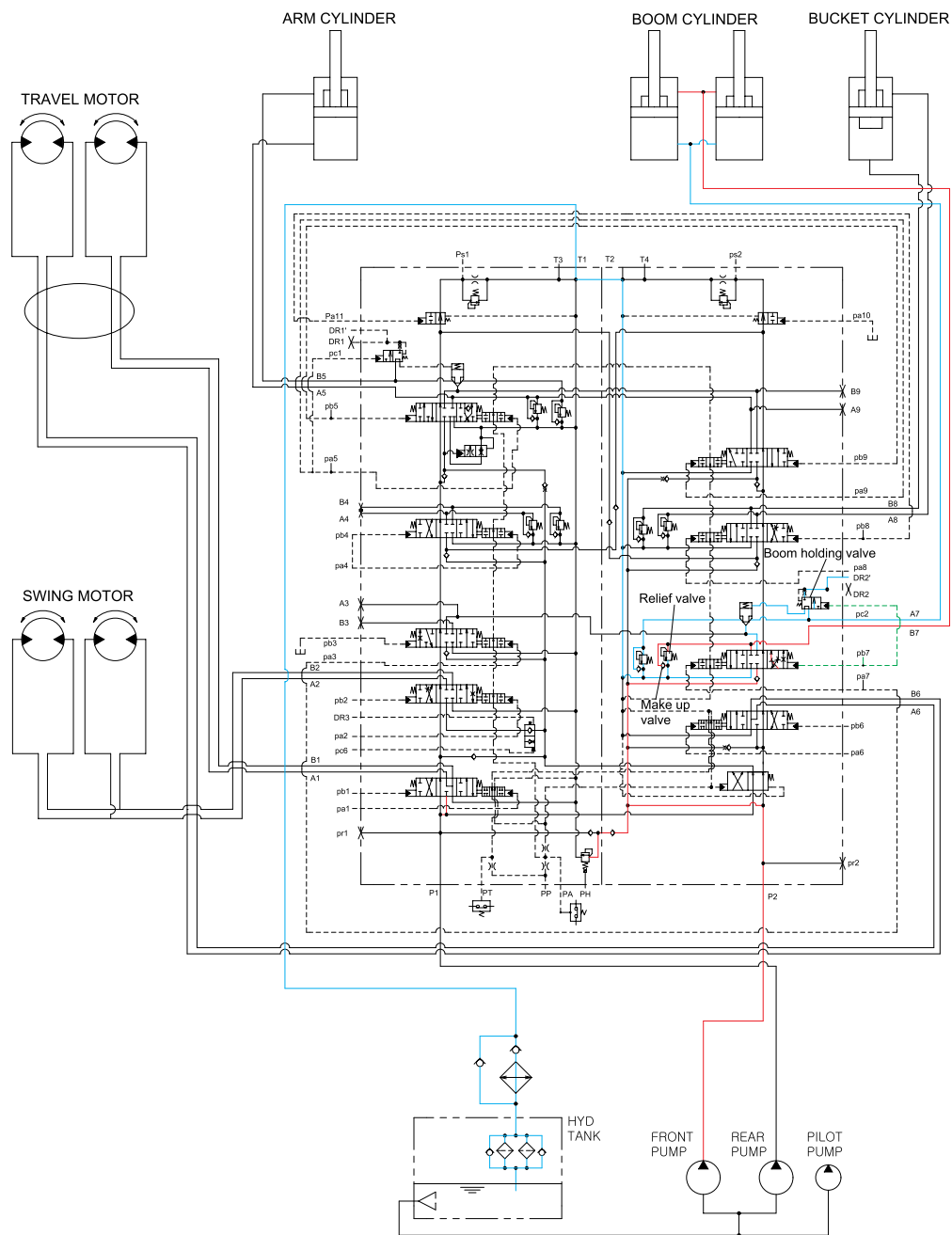

45073HC10

When the RH control lever is pushed forward, the boom spools in the main control valve are moved to the down position by the pilot oil pressure from the remote control valve.

The oil from the front pump flows into the main control valve and then goes to the small chamber of boom cylinders. At the same time, the oil from the large chamber of boom cylinders returns to the hydraulic tank through the boom spool in the main control valve.

When the down speed of boom is faster, the oil returned from the large chamber of boom cylinder combines with the oil from the front pump, and flows into the small chamber of the boom cylinder.

This prevents cylinder cavitation by the negative pressure when the rear pump flow can not match the boom down speed. And the excessive pressure in the boom cylinder rod end circuit is prevented by the relief valve.

3. ARM ROLL IN OPERATION

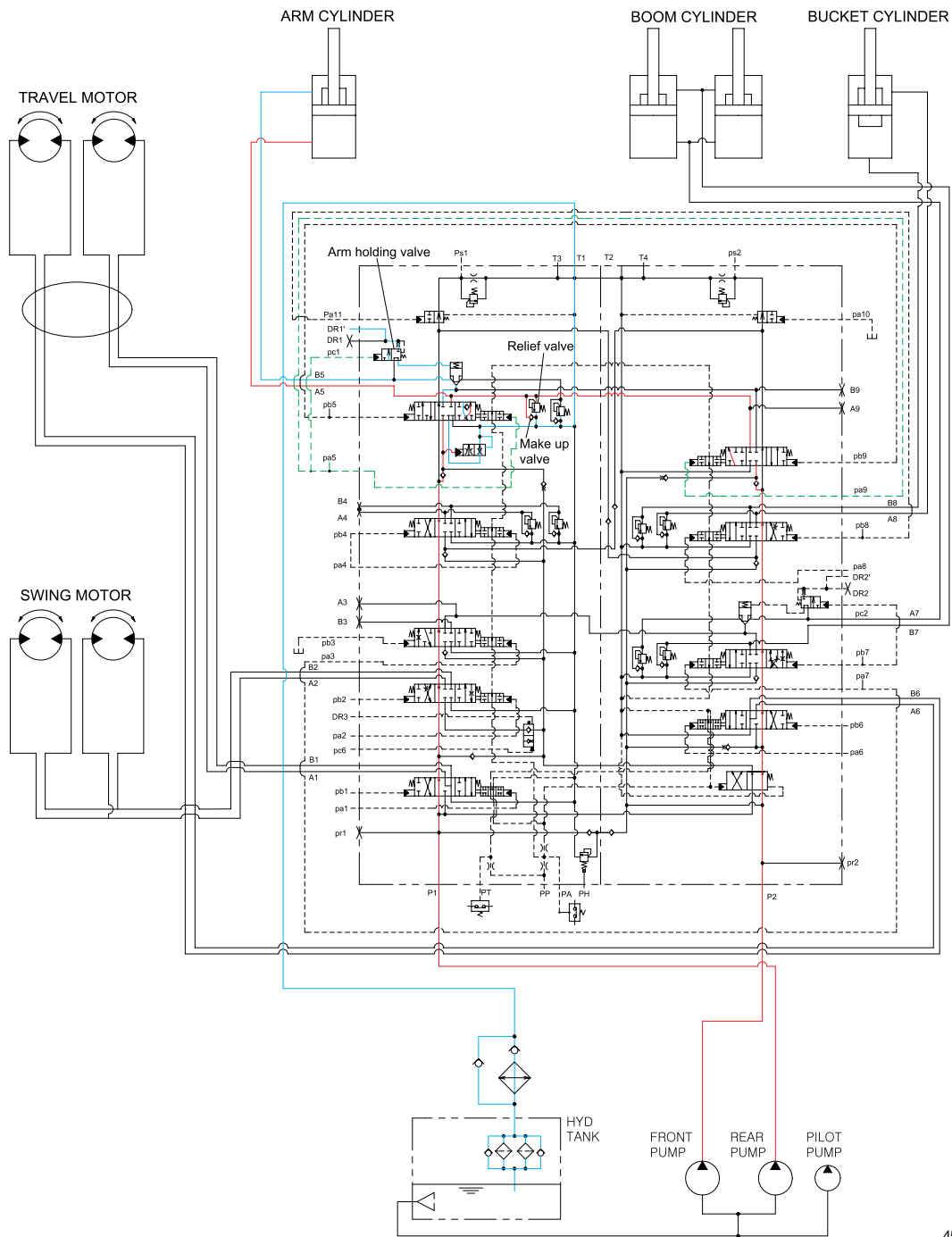

When the LH control lever is pulled back, the arm spools in the main control valve are moved to the roll in position by the pilot oil pressure from the remote control valve.

The oil from the front and rear pump flows into the main control valve and then goes to the large chamber of arm cylinder.

At the same time, the oil from the small chamber of arm cylinder returns to the hydraulic oil tank through the arm spool in the main control valve. When this happens, the arm roll in.

When the roll in speed of arm is faster, the oil returned from the small chamber of arm cylinder combines with the oil from both pump, and flows into the large chamber of the arm cylinder by a make up valve.

The excessive pressure in the arm cylinder bottom end circuit is prevented by relief valve.

4. ARM ROLL OUT OPERATION

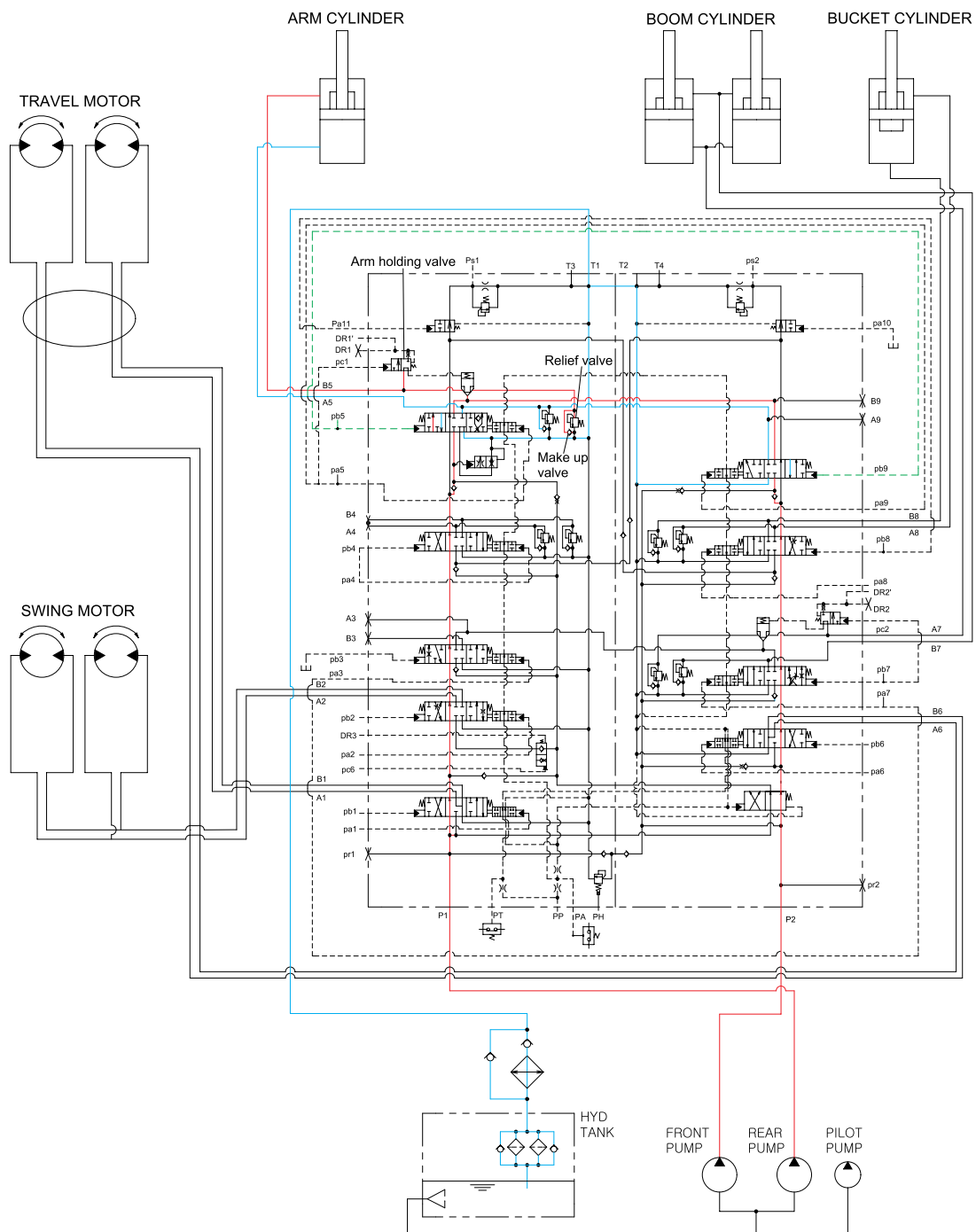

45073HC12

When the LH control lever is pushed forward, the arm spools in the main control valve are moved to the roll out position by the pilot oil pressure from the remote control valve. The oil from the front and rear pump flows into the main control valve and then goes to the small chamber of arm cylinder. At the same time, the oil from the large chamber of arm cylinder returns to the hydraulic oil tank through the arm spool in the main control valve.

When this happens, the arm roll out. The excessive pressure in the arm cylinder rod end circuit is prevented by relief valve. When the arm is rolled out and the control lever is returned to neutral position, the circuit for the holding pressure at the rod end of the arm cylinder is closed by the arm holding valve. This prevents the hydraulic drift of arm cylinder.

5. BUCKET ROLL IN OPERATION

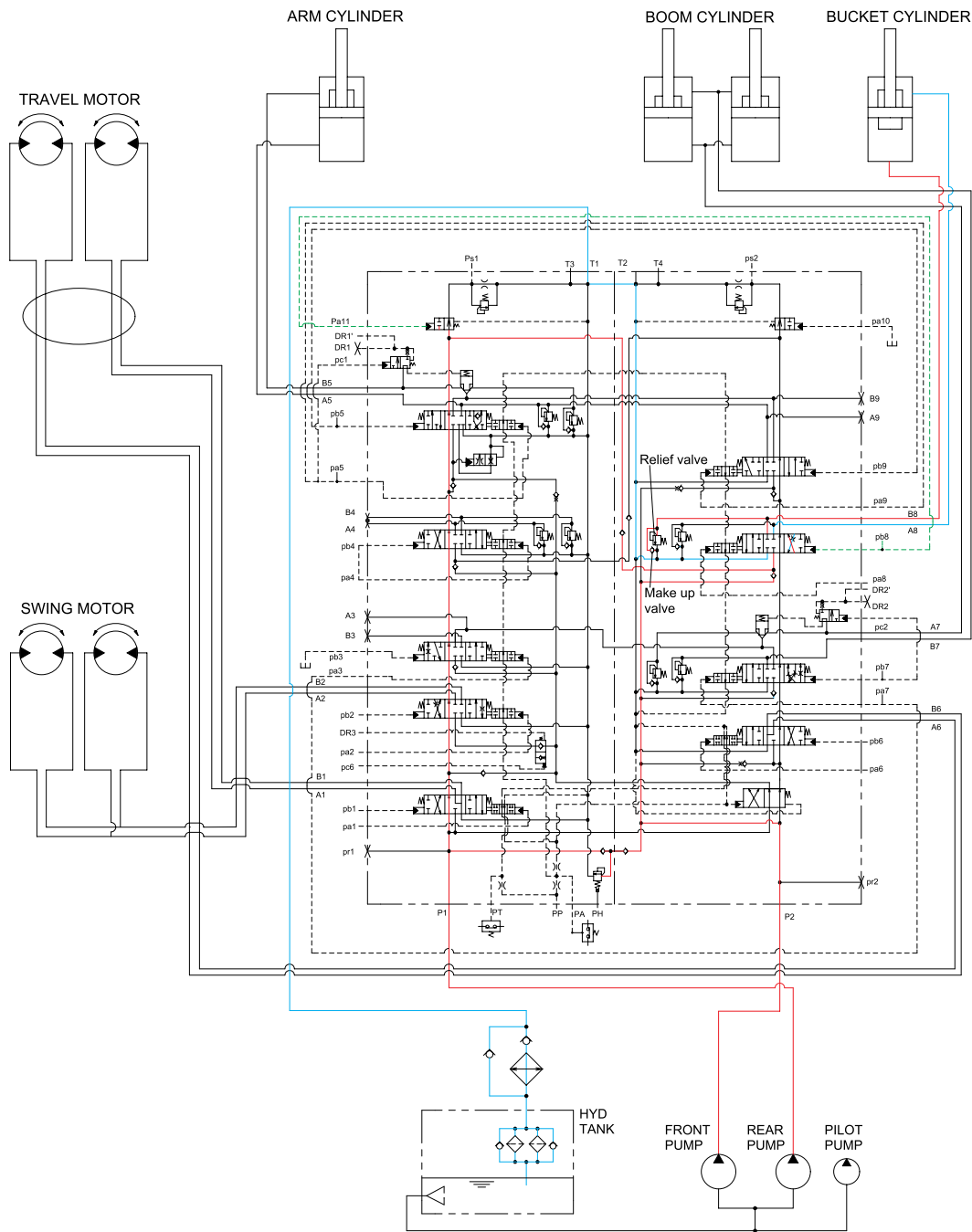

45073HC13

When the RH control lever is pulled left, the bucket spool in the main control valve is moved to the roll in position by the pilot oil pressure from the remote control valve.

The center bypass valve is blocked by pilot pressure (pa11) and then the oil from rear pump is joint to flow of the front pump via confluence passage.

The oil from the front and rear pump flows into the main control valve and then goes to the large chamber of bucket cylinder. At the same time, the oil from the small chamber of bucket cylinder returns to the hydraulic oil tank through the bucket spool in the main control valve. When this happens, the bucket roll in. The cavitation which will happen to the bottom of the bucket cylinder is prevented by the make up valve, on other hand. The excessive pressure is also prevented by an overload relief valve in the main control valve.

6. BUCKET ROLL OUT OPERATION

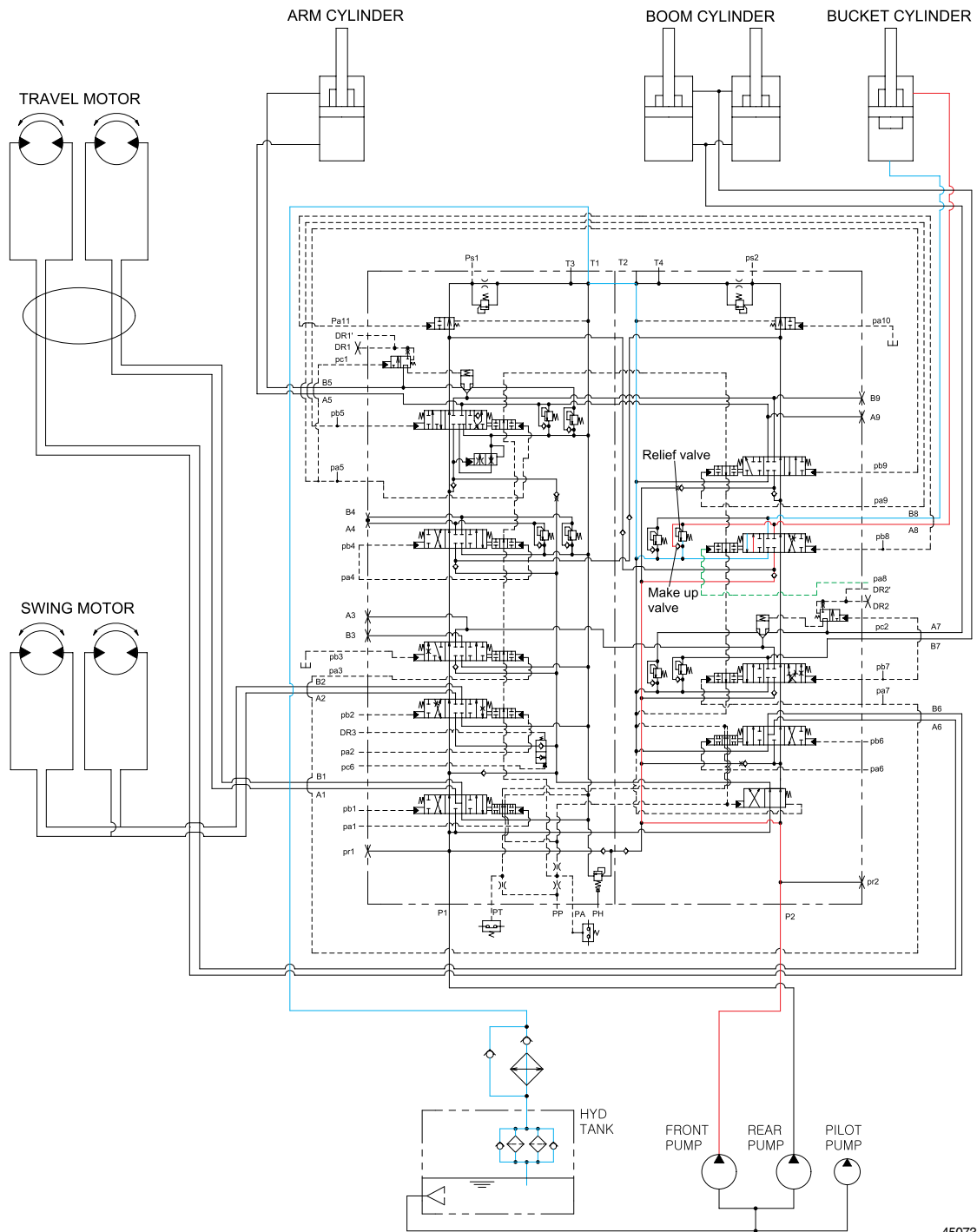

45073HC14

When the RH control lever is placed right, the bucket spool in the main control valve is moved to the roll out position by the pilot oil pressure from the remote control valve.

The oil from the front pump flows into the main control valve and then goes to the small chamber of bucket cylinder. At the same time the oil from the large chamber of bucket cylinder returns to the hydraulic oil tank through the bucket spool in the main control valve. When this happens the bucket roll out.

The cavitation which will happen to the rod of the bucket cylinder is prevented by a make up valve, on other hand. The excessive pressure is also prevented by an overload relief valve in the main control valve.

7. SWING OPERATION

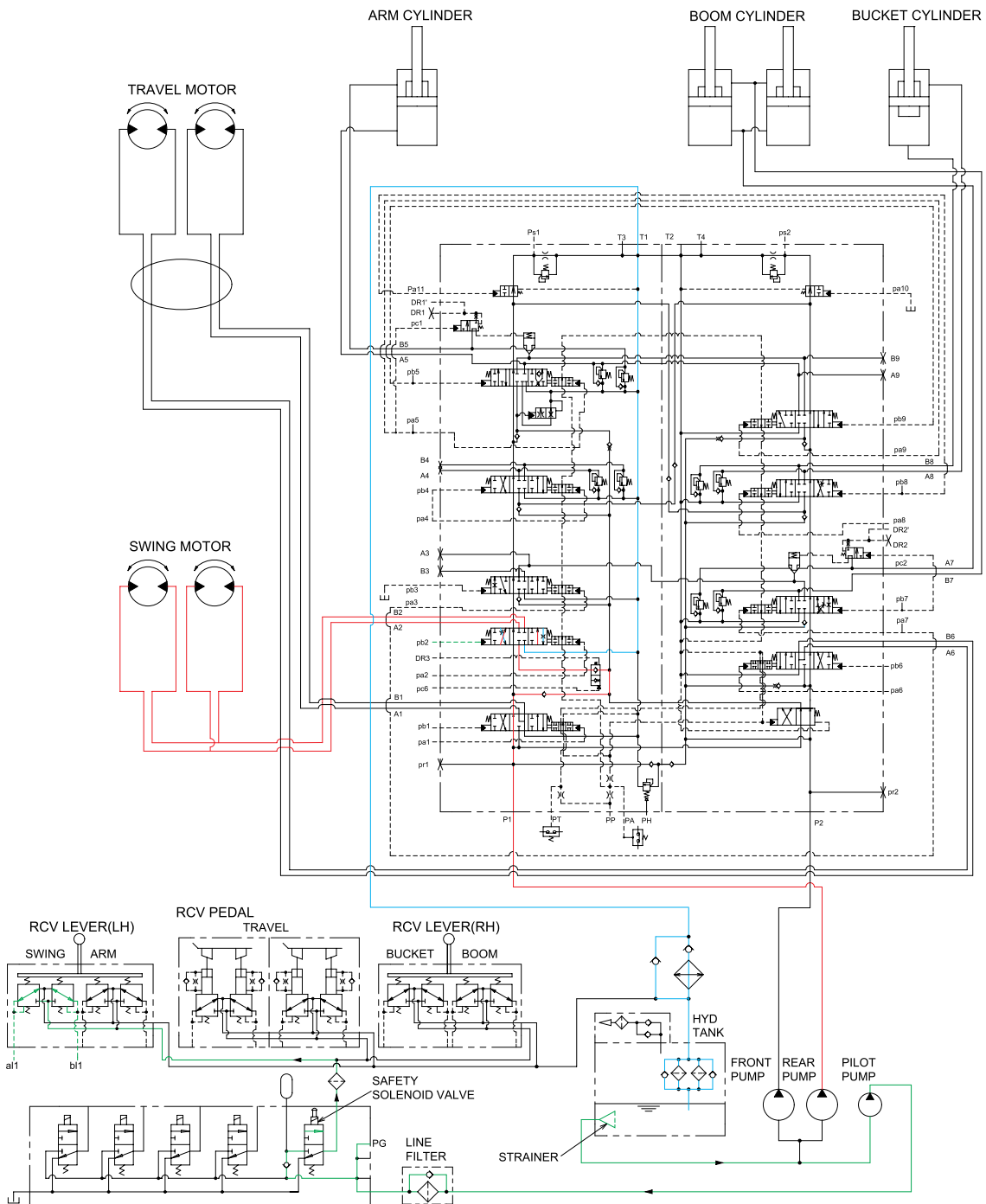

45073HC15

When the LH control lever is placed left or right, the swing spool in the main control valve is moved to the left or right swing position by the pilot oil pressure from the remote control valve.

The oil from the rear pump flows into the main control valve and then goes to the swing motor.

At the same time, the return oil from the swing motor returns to the hydraulic oil tank through the swing spool in the main control valve.

When this happens, the superstructure swings to the left or right.

The swing parking brake, make up valve and the motor brake valve are provided in the swing motors.

The cavitation which will happen to the swing motor is also prevented by the make up valve in the swing motor itself.

SWING CIRCUIT OPERATION

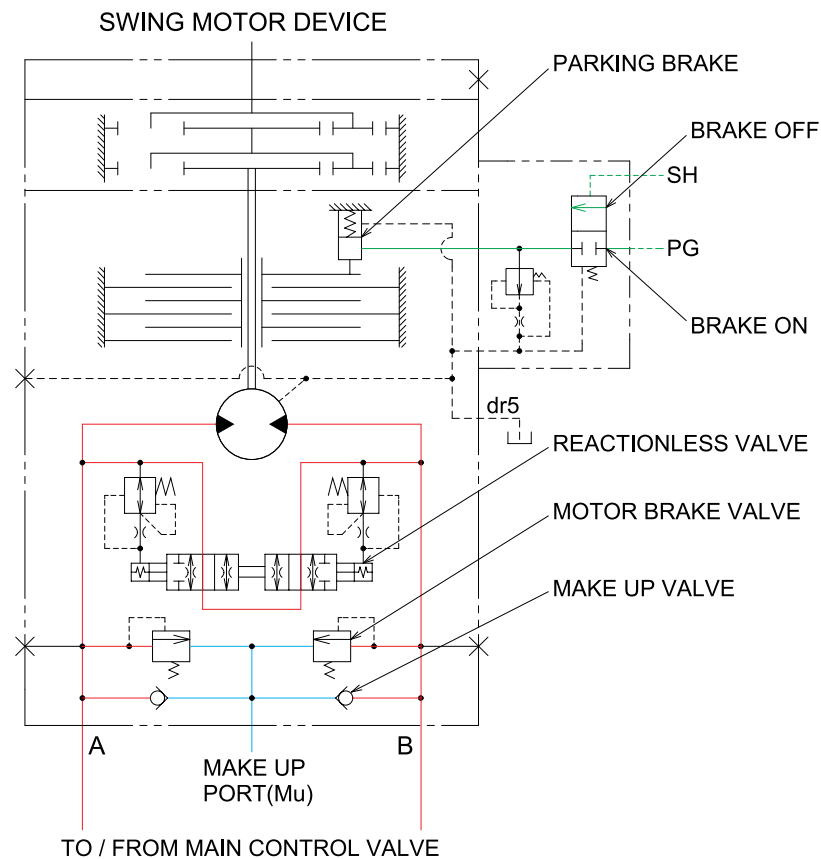

45073HC15-1

1) MOTOR BRAKE VALVE

Motor brake valve for the swing motor limits to cushion the starting and stopping pressure of swing operation.

2) MAKE UP VALVE

The make up valves prevent cavitation by supplying return oil to the vacuum side of the motor.

3) PARKING BRAKE

In case that the parking, of the machine at slope is required during operation, there is the danger of involuntary swing caused by the self weight of the machine. The brake is connected to prevent this involuntary swing.

PARKING BRAKE "OFF" OPERATION

The parking brake is released by the pilot pressure oil from the pilot pump.

When the left control lever placed in the swing position, the pilot oil flows into SH port through the MCV. This pressure transferred to the brake release valve and the brake release valve is change over. Then the pilot pressure lift the brake piston and release the parking brake.

PARKING BRAKE "ON" OPERATION

When the control lever placed in the neutral position, the pressure of the pilot oil passage down.

Then the brake release valve returned to the neutral position and the oil is returned from the brake piston to the tank. And the brake is set to 'ON'.

4) REACTIONLESS VALVE

This bypass valve absorbs shocks produced as swing motion stops and reduced oscillation cause by swing motion.

8. TRAVEL FORWARD AND REVERSE OPERATION

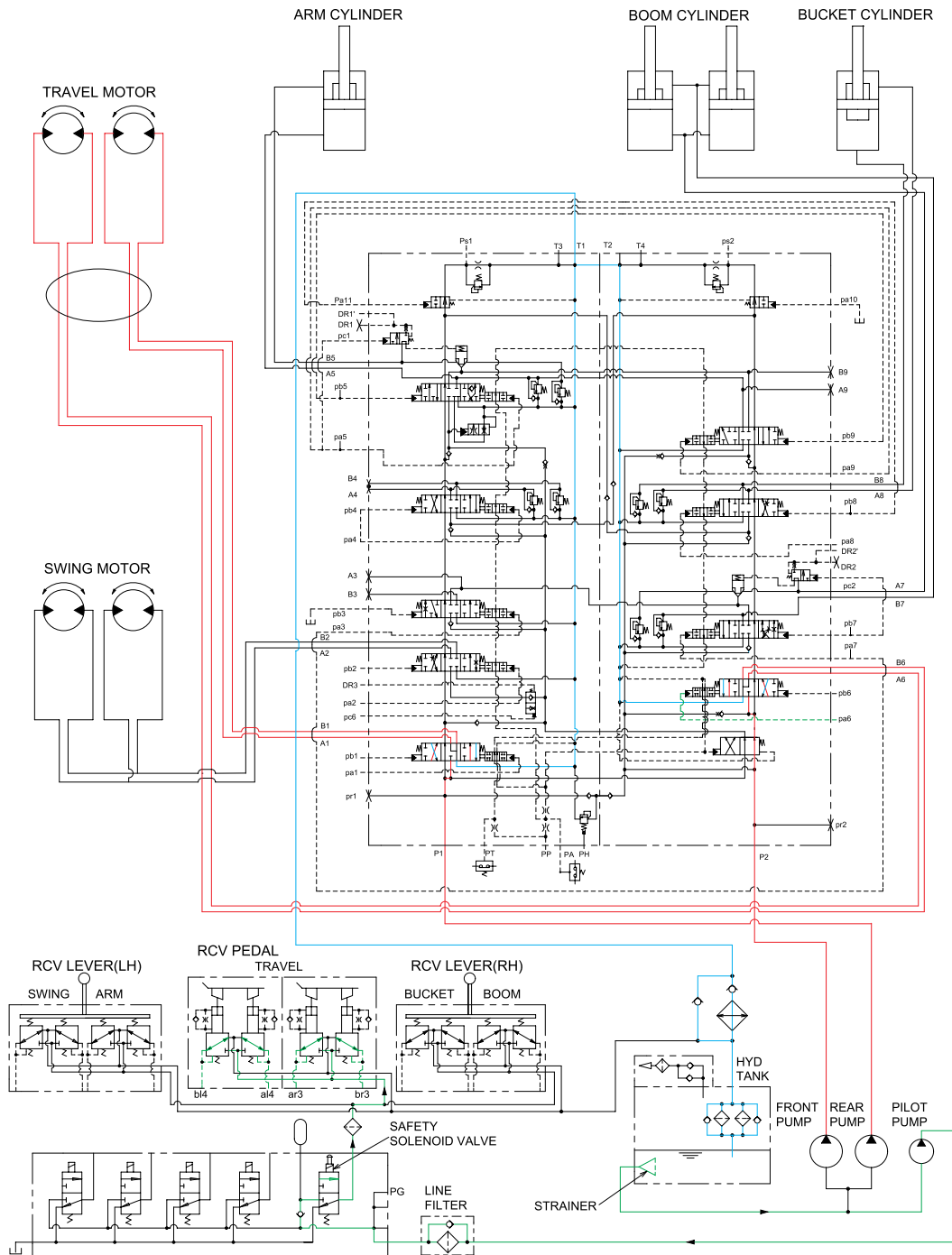

45073HC16

When the travel levers are placed forward or reverse position, the travel spools in the main control valve are moved to the forward or reverse travel position by the pilot oil pressure from the remote control valve.

The oil from the both pumps flow into the main control valve and then go to the both travel motors through the turning joint.

The return oil from both travel motors returns to the hydraulic oil tank through the turning joint and the travel(RH, LH) spools in the main control valve.

When this happens, the machine moves to the forward or reverse.

TRAVEL CIRCUIT OPERATION

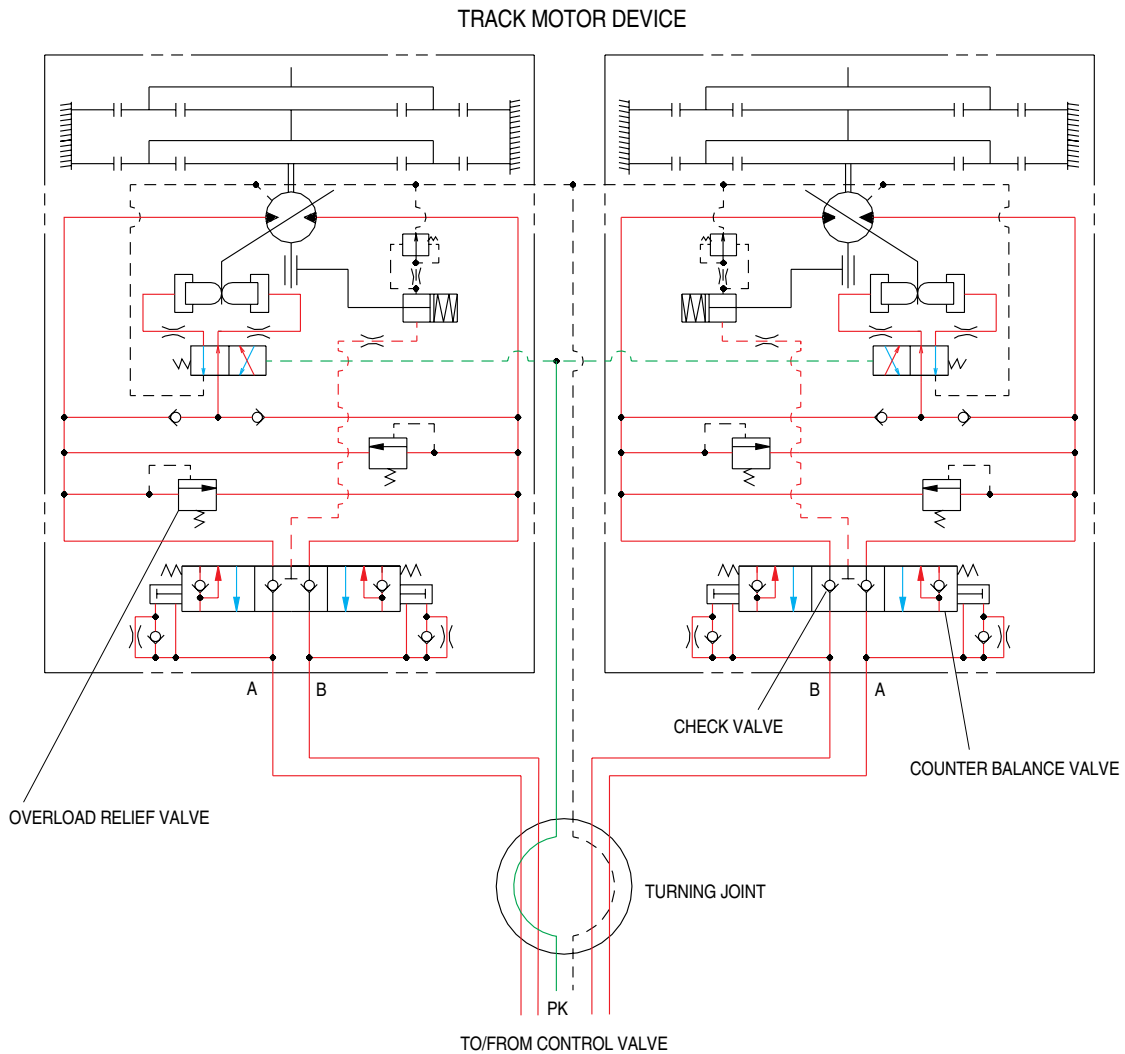

3-20 (210-7)

Valves are provided on travel motors to offer the following functions.

1) CHECK VALVE

Stopping the motor, this valve sucks the oil from lower pressure passage for prevention the negative pressure and the cavitation of the motor.

2) COUNTER BALANCE VALVE

When stopping the motor of slope descending, this valve to prevent the motor over run.

3) OVERLOAD RELIEF VALVE

Relief valve limit the circuit pressure below 345kgf/cm^2 to prevent high pressure generated at a time of stopping the machine. Stopping the motor, this valve sucks the oil from lower pressure passage for preventing the negative pressure and the cavitation of the motor.