

SECTION 4 ELECTRICAL SYSTEM

Group 1 Component Location	4-1
Group 2 Electrical Circuit	4-3
Group 3 Electrical Component Specification	4-20
Group 4 Connectors	4-28

SECTION 4 ELECTRICAL SYSTEM

GROUP 1 COMPONENT LOCATION

1. LOCATION 1

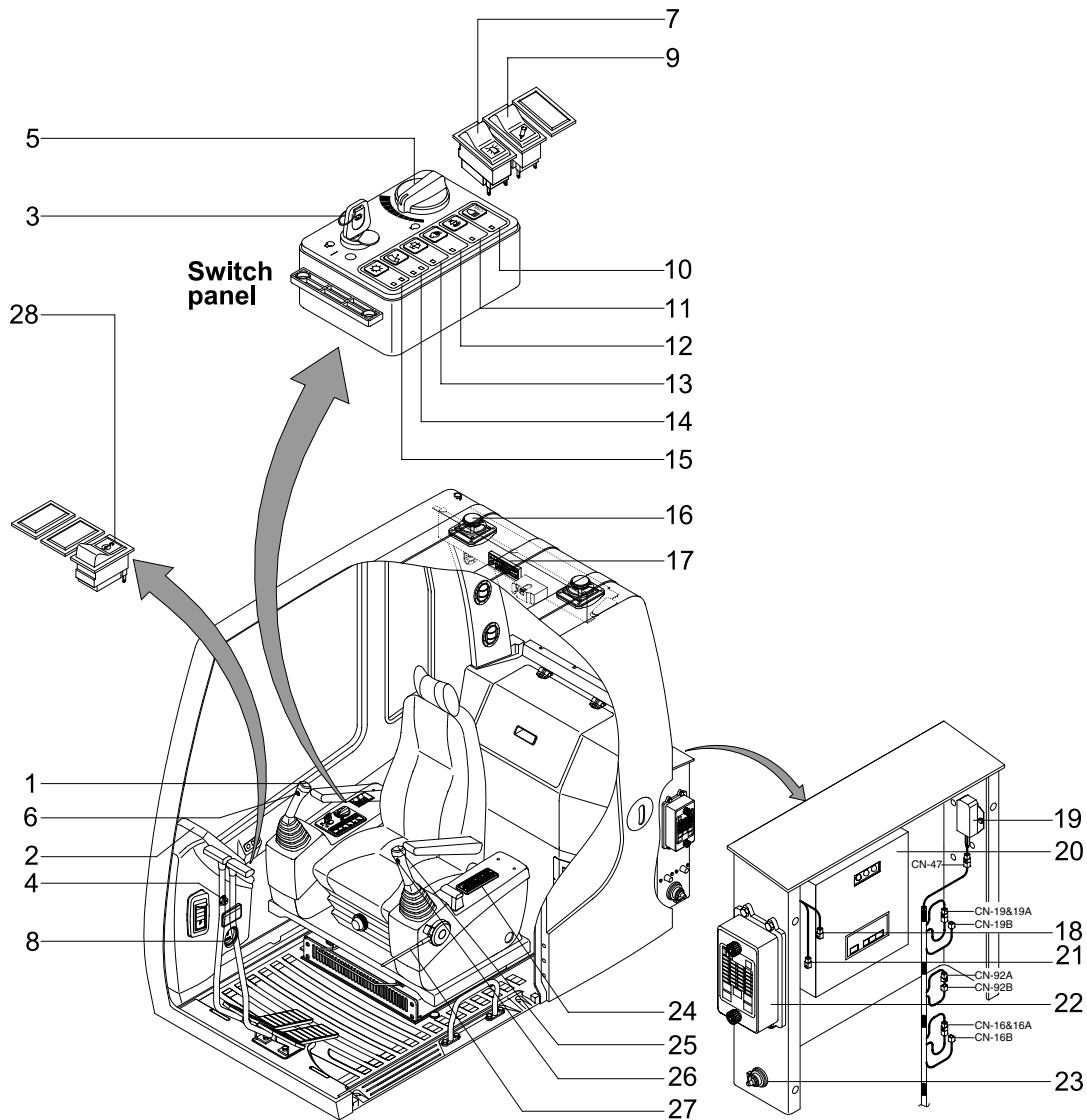

50074EL01

- | | | | | | |
|----|--------------------------|----|--------------------------|----|------------------------------|
| 1 | Horn switch | 11 | Travel alarm stop switch | 20 | CPU controller |
| 2 | Cluster | 12 | Preheat switch | 21 | J1939 serial connector |
| 3 | Starting switch | 13 | Washer switch | 22 | Fuse box |
| 4 | Cigar lighter | 14 | Wiper switch | 23 | Master switch |
| 5 | Accel dial | 15 | Main light switch | 24 | Aircon & heater switch panel |
| 6 | Breaker switch | 16 | Speaker | 25 | One touch decel switch |
| 7 | Beacon switch | 17 | Cassette & radio | 26 | Power max switch |
| 8 | Service meter | 18 | RS232 serial connector | 27 | Safety lever |
| 9 | Breaker selection switch | 19 | Prolix resistor | 28 | Overload switch |
| 10 | Cab light switch | | | | |

2. LOCATION 2

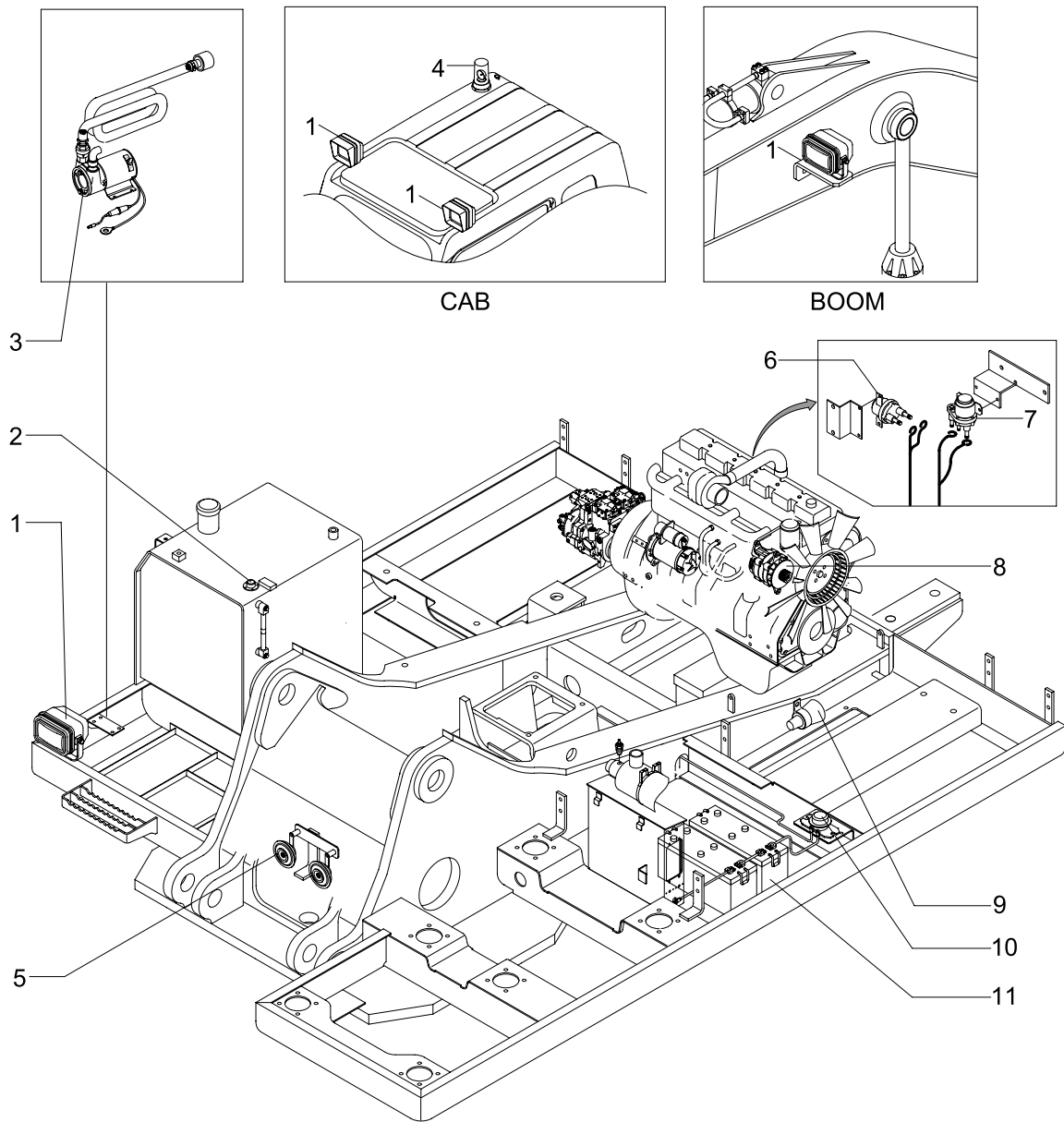

4507A4EL02

- | | | | | | |
|---|------------------|---|--------------|----|---------------------|
| 1 | Lamp | 5 | Horn | 9 | Travel alarm buzzer |
| 2 | Fuel sender | 6 | Start relay | 10 | Battery relay |
| 3 | Fuel filler pump | 7 | Heater relay | 11 | Battery |
| 4 | Beacon lamp | 8 | Alternator | | |