

GROUP 7 WORK EQUIPMENT

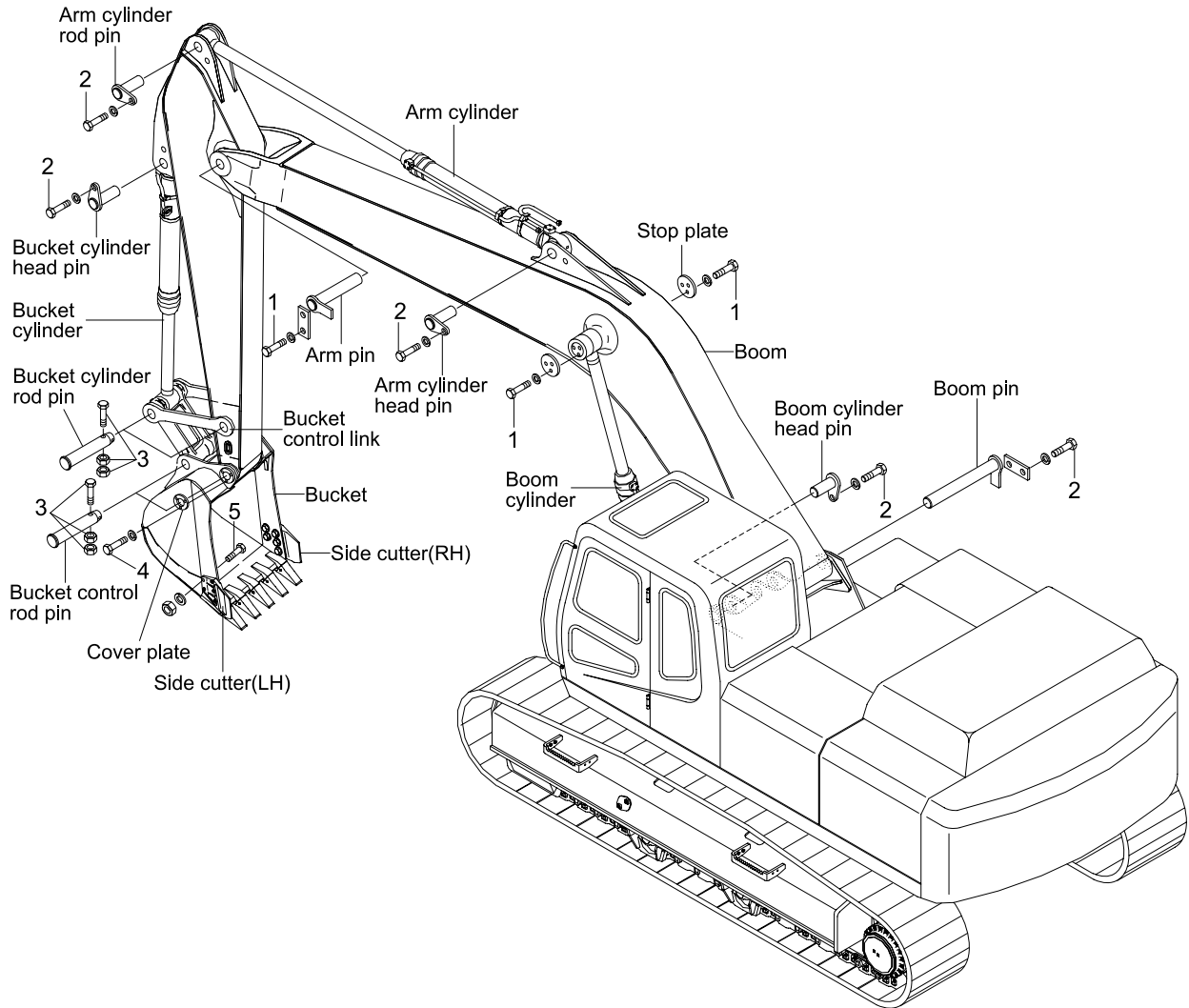

45079CM13

· Tightening torque

Item	Size	kgf · m	lbf · ft
1	M12×1.75	12.8±3.0	92.6±21.7
2	M16×2.0	29.7±4.5	215±32.5
3	M24×3.0	100±15	723±108

Item	Size	kgf · m	lbf · ft
4	M27×3.0	135±15	977±109
5	M30×3.5	199±30	1439±217
-	-	-	-