

GROUP 2 MODE SELECTION SYSTEM

1. POWER MODE SELECTION SYSTEM

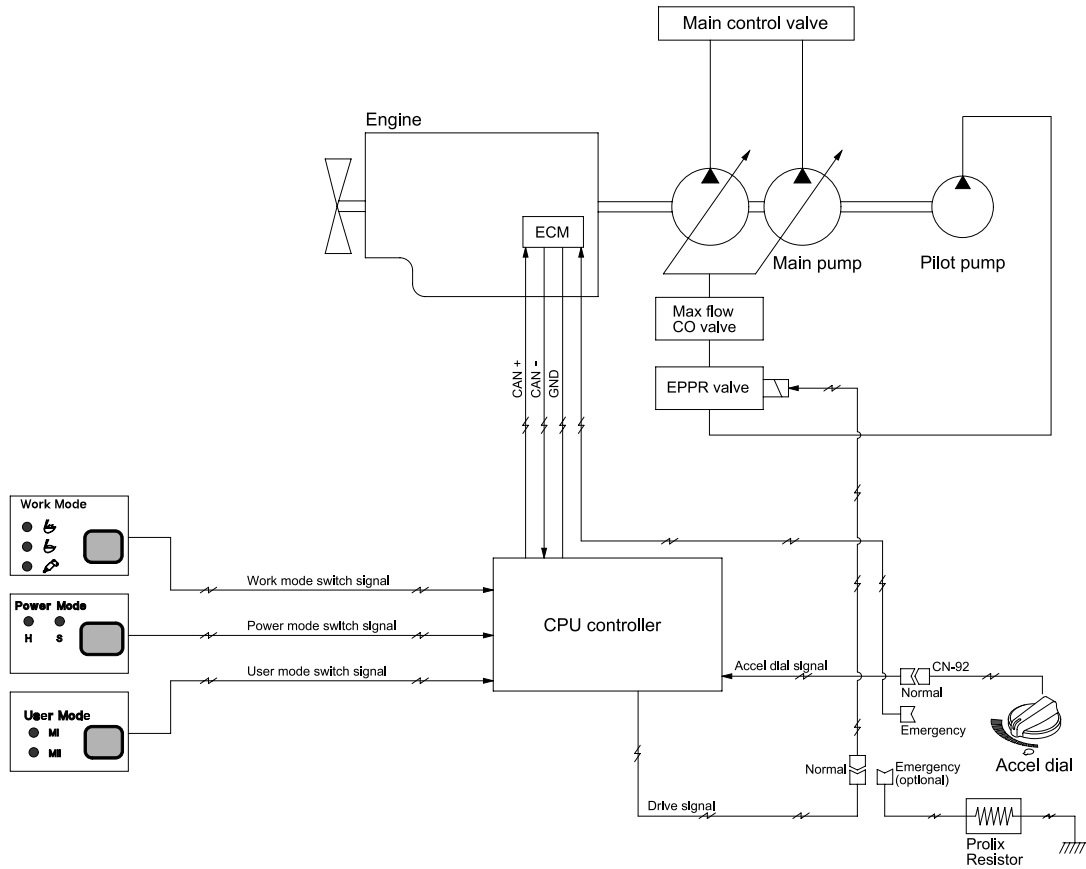

36075MS02

Mode selection system(Micro computer based electro-hydraulic pump and engine mutual control system) optimizes the engine and pump performance.

The combination of 2 power modes(H, S) and accel dial position(10 set) makes it possible to use the engine and pump power more effectively corresponding to the work conditions from a heavy and great power requesting work to a light and precise work.

Mode	Application	Power set (%)	Engine rpm		Power shift by EPPR valve			
			Unload	Load	Ver 5.X(STD)		Ver 6.X(STD)	
					Current (mA)	Pressure (kgf/cm ²)	Current (mA)	Pressure (kgf/cm ²)
M	Maximum power	95	1950 ± 50	1900	260 ± 30	4	160 ± 30	0
H	High power	85	1850 ± 50	1800	320 ± 30	6	260 ± 30	4
S	Standard power	70	1750 ± 50	1700	320 ± 30	6	320 ± 30	6
AUTO DECEL	Engine deceleration	-	1000 ± 100	-	670 ± 30	35	670 ± 30	35
One touch decel	Engine quick deceleration	-	800 ± 100	-	700 ± 30	35	700 ± 30	35
KEY START	Key switch start position	-	800 ± 100	-	700 ± 30	35	700 ± 30	35

2. WORK MODE SELECTION SYSTEM

3 work modes can be selected for the optional work speed of the machine operation.

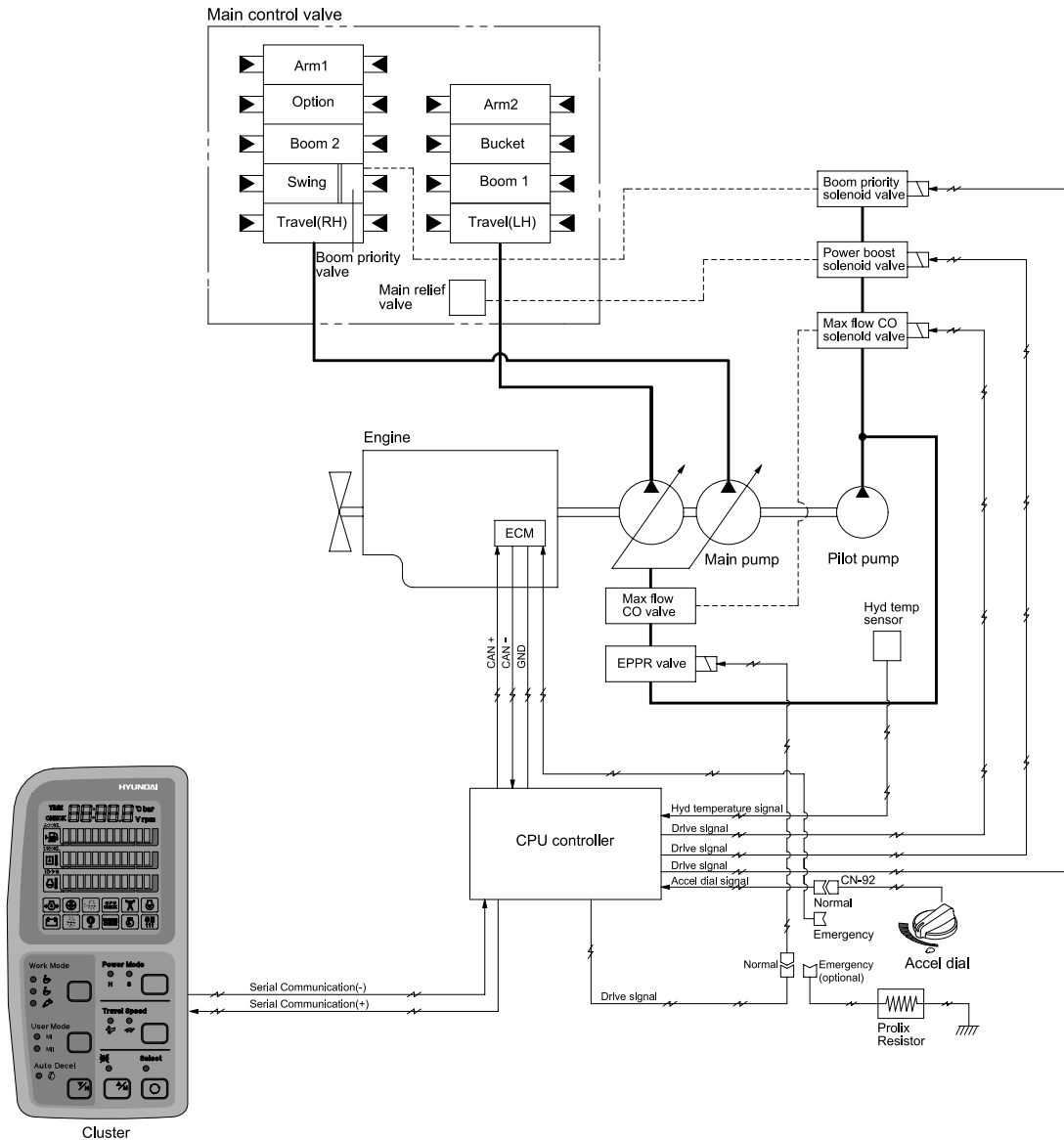

45075MS03

1) HEAVY DUTY WORK MODE

The boom priority solenoid is activated to make the boom operation speed faster.

2) GENERAL WORK MODE

When key switch is turned ON, this mode is selected and swing operation speed is faster than heavy duty work mode.

3) BREAKER OPERATION MODE

It sets the pump flow to the optimal operation of breaker by activating the max flow cut-off solenoid.

Work mode	Boom priority solenoid	Max flow cut-off solenoid
Heavy duty	ON	OFF
General	OFF	OFF
Breaker	OFF	ON

3. USER MODE SELECTION SYSTEM

Through 2 memory sets of MI and MII, an operator can change the engine and pump power and memorize it for his preference.

Mode	Operation
U	High idle rpm, auto decel rpm EPPR pressure can be modulated and memorized separately

HOW TO MODULATE THE MEMORY SET

- Each memory mode has a initial set which are mid-range of max engine speed, auto decel rpm, and EPPR valve input current. When you select "U", cluster LCD displays.
- To change the engine high idle speed, press the USER mode switch and SELECT switch at the same time and then ACCEL blinks at 0.5 seconds interval.
 - By pressing ▲ or ▼ switch, █ will increase or decrease.
- To change DECEL rpm, press the USER mode switch and SELECT switch once more and then DECEL blinks at 0.5 seconds interval.
 - By pressing ▲ or ▼ switch, █ will increase or decrease.
- To change EPPR current, press the USER mode switch and SELECT switch one more and then EPPR blinks at 0.5 seconds interval.
 - By pressing ▲ or ▼ switch, █ will increase or decrease.

· LCD segment vs parameter setting

Segment (█)	ACCEL (rpm)	DECEL (rpm)	EPPR (mA)
1	High idle-900	Low idle(800)	150
2	High idle-800	850	200
3	High idle-700	900	250
4	High idle-600	950	300
5	High idle-500	Decel rpm(1000)	350
6	High idle-400	1050	400
7	High idle-300	1100	450
8	High idle-200	1150	500
9	High idle-100	1200	550
10	High idle	1250	600

- To memorize the final setting, press the USER mode switch and SELECT switch one more time.

