

GROUP 4 MECHATRONICS SYSTEM

1. ALL ACTUATORS SPEED ARE SLOW

- ※ Boom, Arm, Bucket, Swing and travel speed are slow, but engine speed is good.
- ※ Spec : H-mode 1950 ± 50rpm S-mode 1850 ± 50rpm
- ※ Before carrying out below procedure, check all the related connectors are properly inserted.

1) INSPECTION PROCEDURE

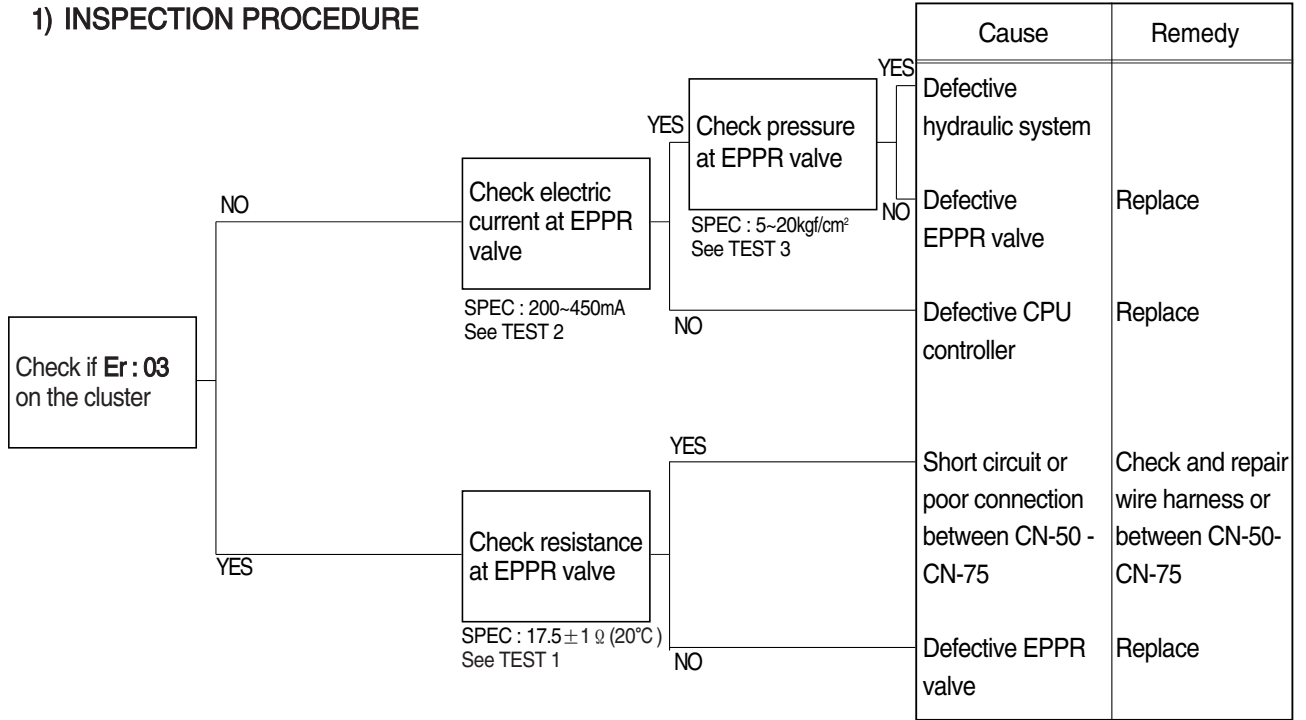

Wiring diagram

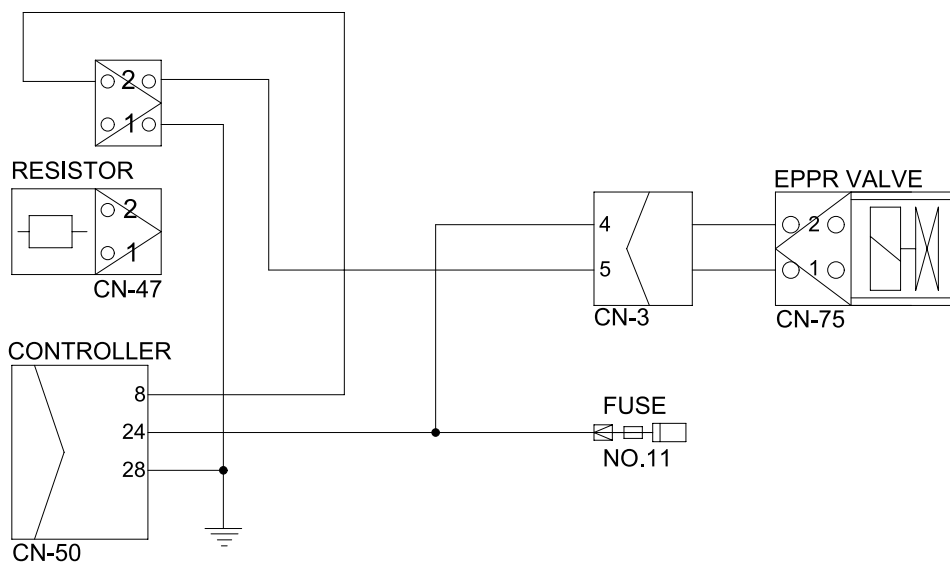

2) TEST PROCEDURE

(1) Test 1 : Check resistance at connector CN-75.

- ① Starting key OFF.
- ② Disconnect connector CN-75 from EPPR valve at main hydraulic pump.
- ③ Check resistance between 2 lines as figure.

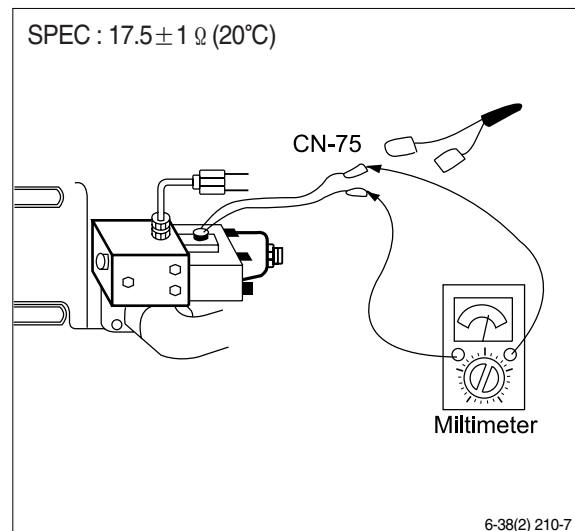

(2) Test 2 : Check electric current at EPPR valve.

- ① Install multimeter as figure.
- ② Start engine.
- ③ Set the accel dial at "10"(MAX)
- ④ Set S-mode and cancel auto decel
- ⑤ mode.

If tachometer show approx 1850 ± 50 rpm, check electric current.

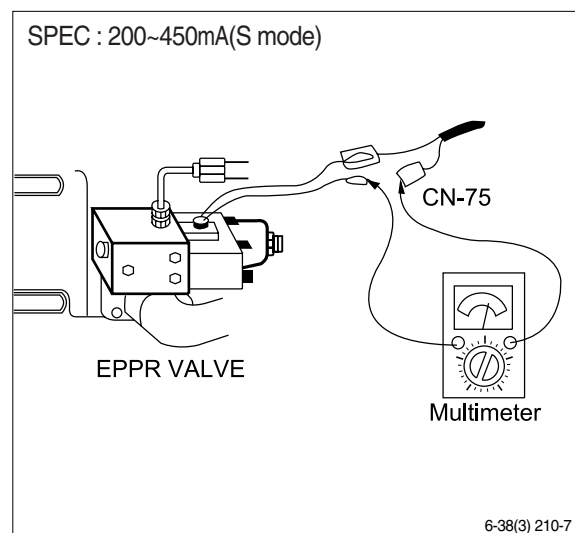

(3) Test 3 : Check pressure at EPPR valve.

- ① Remove plug and connect pressure gauge as figure.
 - Gauge capacity : 0 to 40~50kgf/cm²
(0 to 570~710psi)
- ② Start engine.
- ③ Set the accel dial at "10"(Max).
- ④ Set S-mode and cancel auto decel
- ⑤ mode.
- ⑥ check pressure.
- ⑦ If pressure is not correct, adjust it.
After adjust, test the machine.

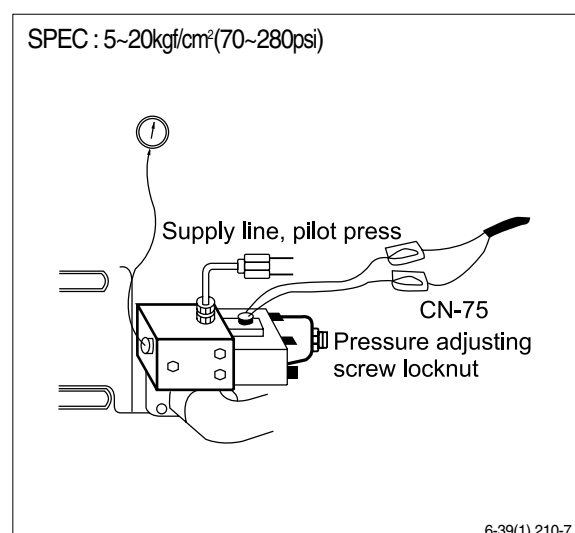

2. ENGINE STALL

※ Before carrying out below procedure, check all the related connectors are properly inserted.

1) INSPECTION PROCEDURE

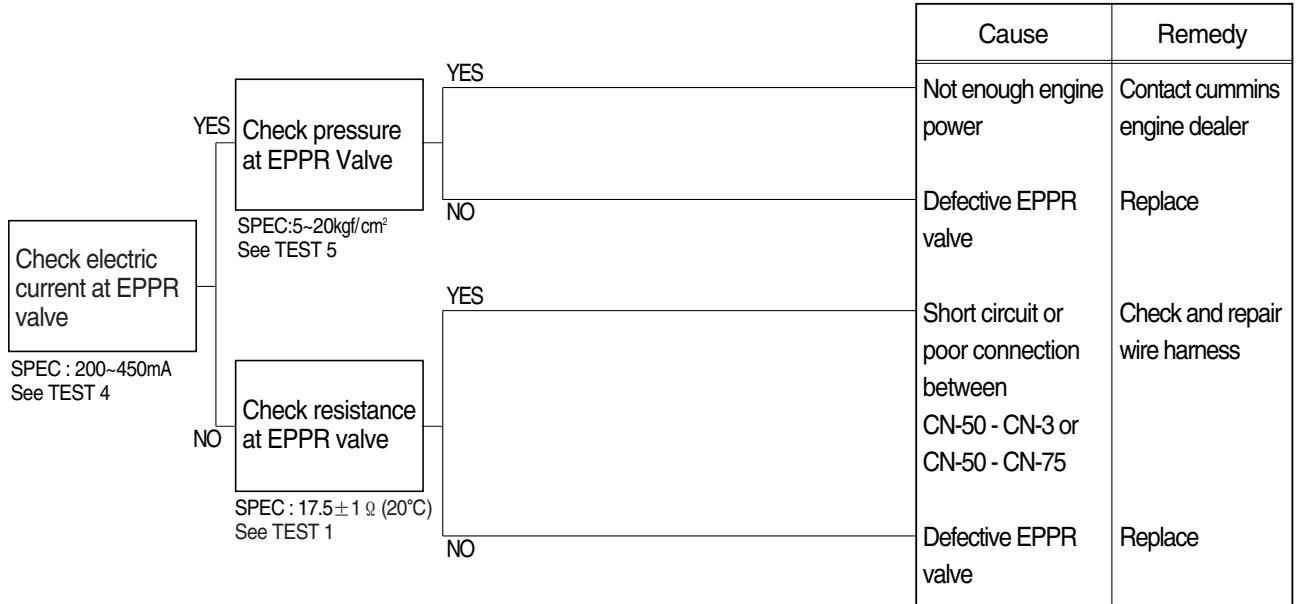

Wiring diagram

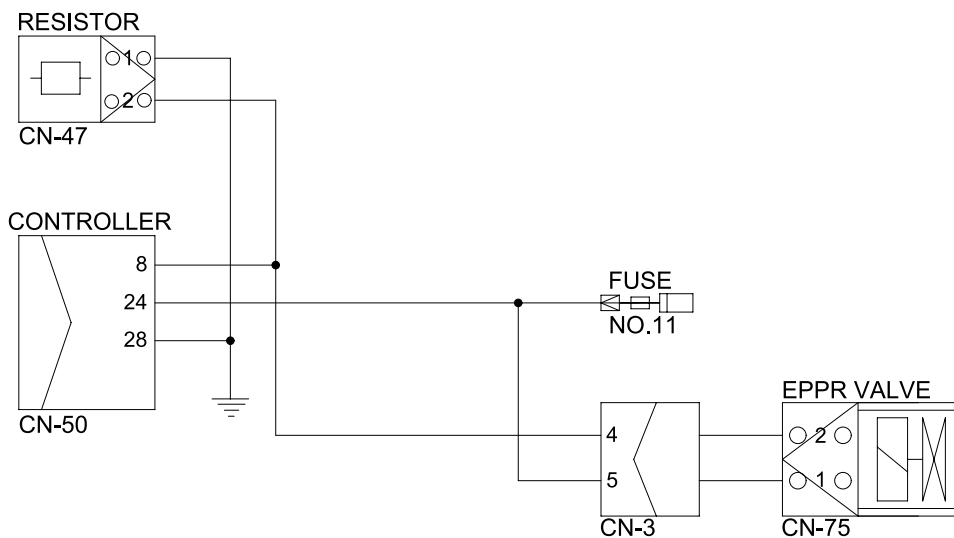

45076MS02

2) TEST PROCEDURE

(1) Test 4 : Check electric current at EPPR valve at S-mode

- ① Install multimeter as figure.
- ② Start engine.
- ③ Set the accel dial at "10"(max)
- ④ Set S-mode with 1850 ± 50 rpm.
- ⑤ Check electric current.

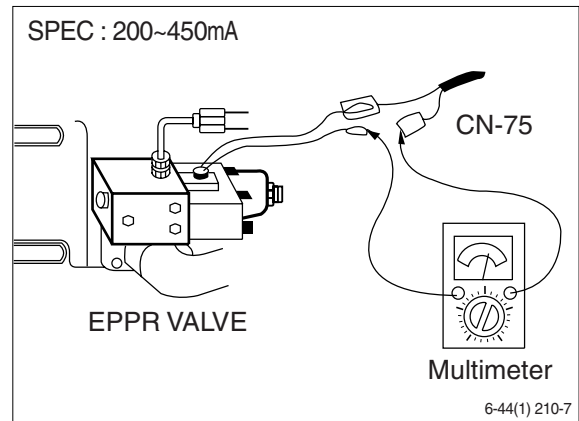

(2) Test 5 : Check pressure at EPPR valve at S-mode

- ① Connect pressure gauge at EPPR valve.
- ② Start engine.
- ③ Set the accel dial at "10"(max)
- ④ Set S-mode with 1850 ± 50 rpm.
- ⑤ Operate bucket lever completely push or pull.
- ⑥ Hold arm lever at the end of stroke.
- ⑦ Check pressure at relief position.

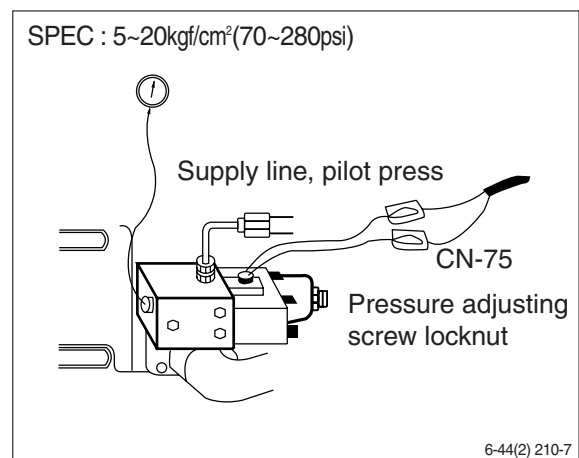

3. MALFUNCTION OF CLUSTER OR MODE SELECTION SYSTEM

※ Before carrying out below procedure, check all the related connectors are properly inserted.

1) INSPECTION PROCEDURE

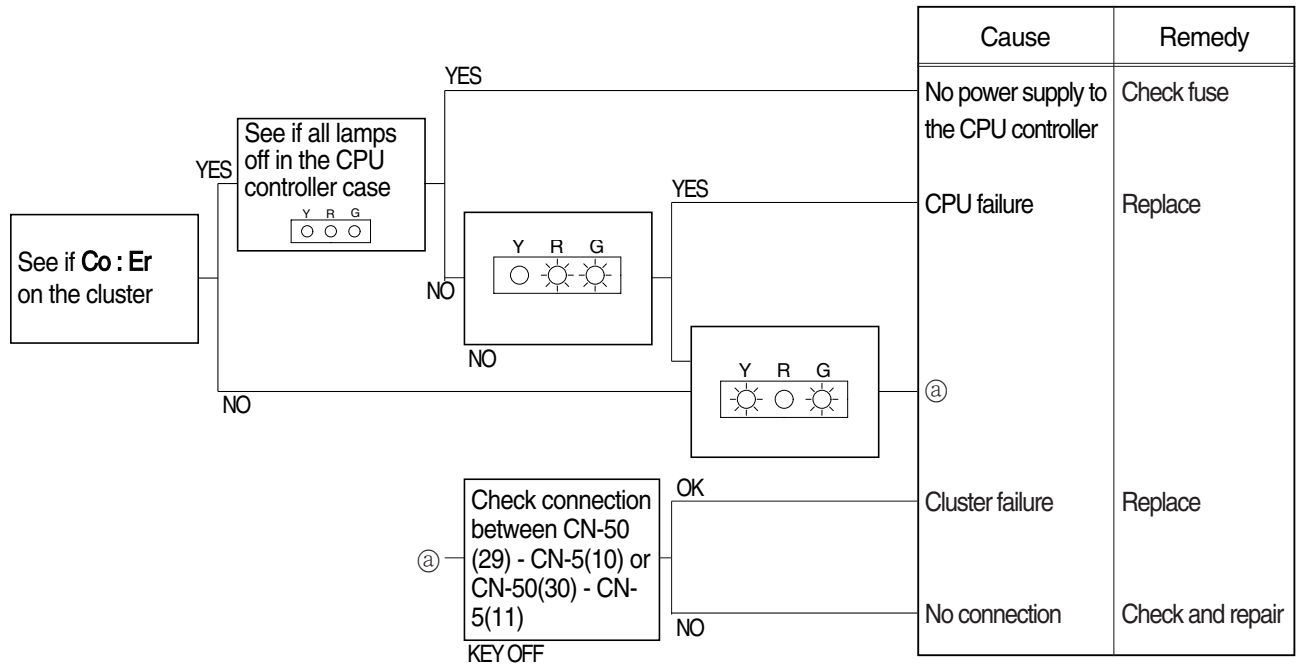

Wiring diagram

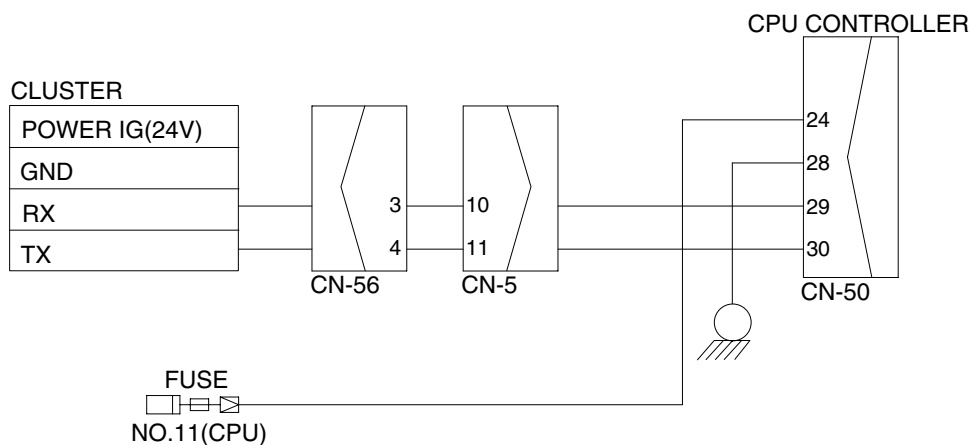

4. AUTO DECEL SYSTEM DOES NOT WORK

※ Before carrying out below procedure, check all the related connectors are properly inserted.

1) INSPECTION PROCEDURE

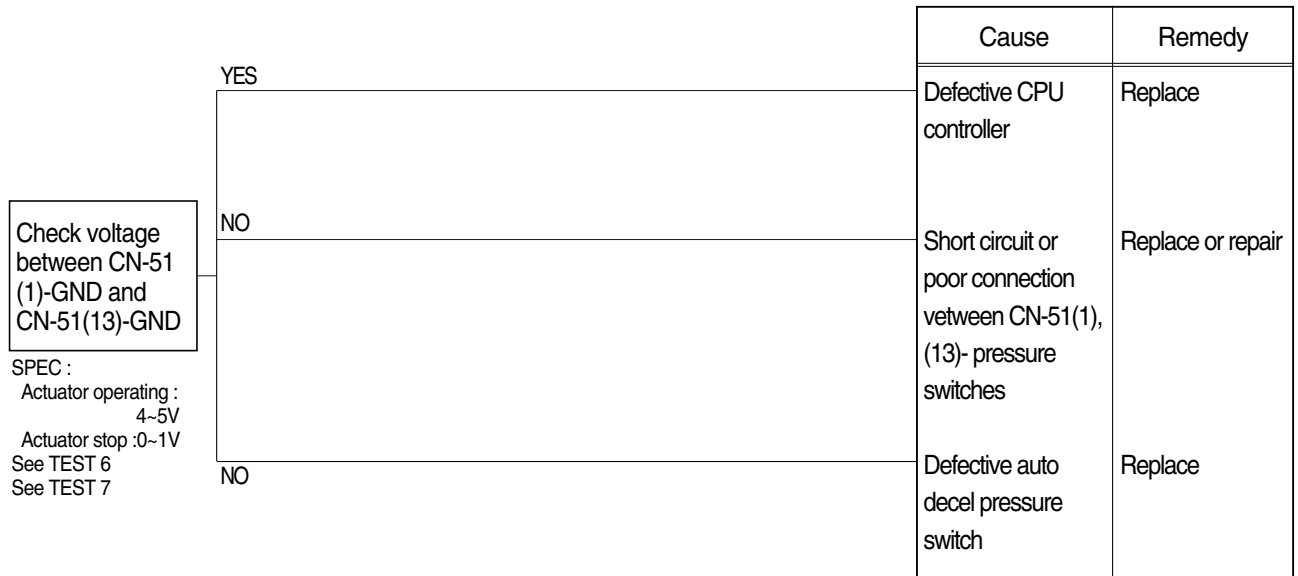

Wiring diagram

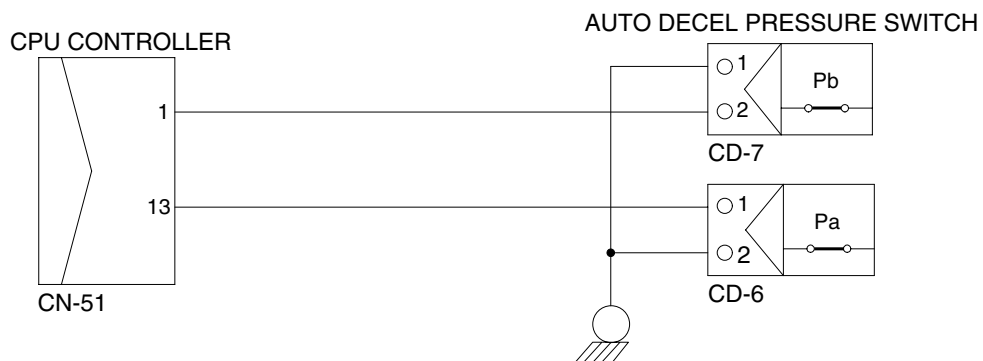

29076MS10

2) TEST PROCEDURE

(1) **Test 6** : Check voltage at CN-51(1) and ground.

- ① Prepare 1 piece of thin sharp pin, steel or copper.
- ② Starting key ON.
- ③ Insert prepared pin to rear side of connectors : One pin to (1) of CN-51.
- ④ Check voltage as figure.

(2) **Test 7** : Check voltage at CN-51(13) and ground.

- ① Prepare 1 piece of thin sharp pin, steel or copper
- ② Starting key ON.
- ③ Insert prepared pin to rear side of connectors : One pin to (13) of CN-51
- ④ Check voltage as figure.

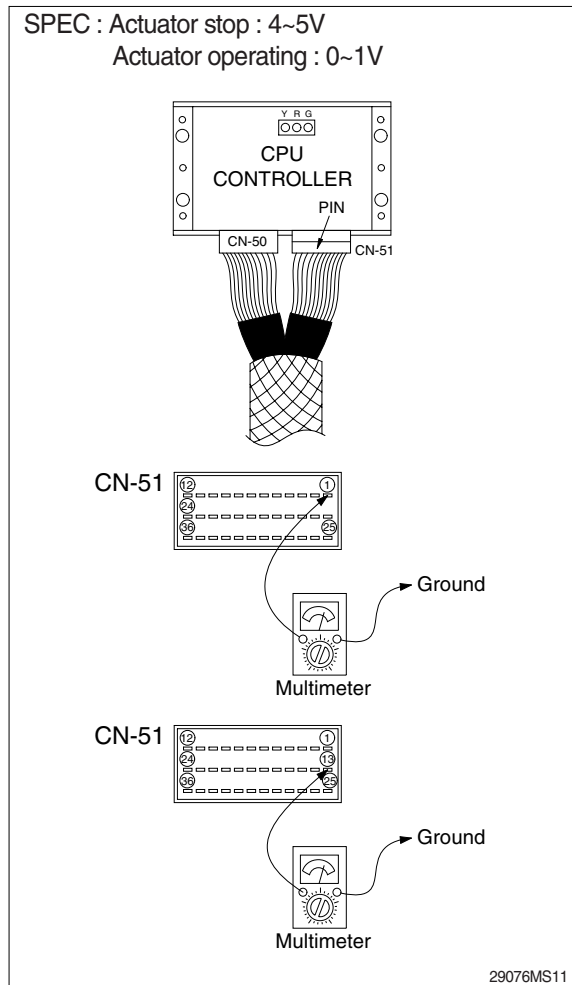

5. MALFUNCTION OF WARMING UP

※ Before carrying out below procedure, check all the related connectors are properly inserted.

1) INSPECTION PROCEDURE

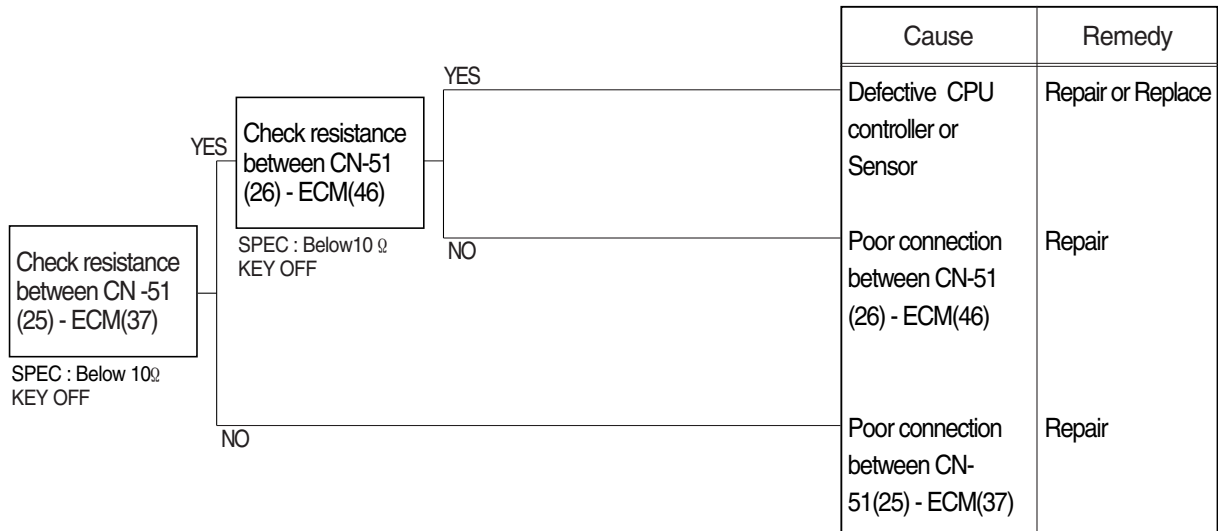

Wiring diagram

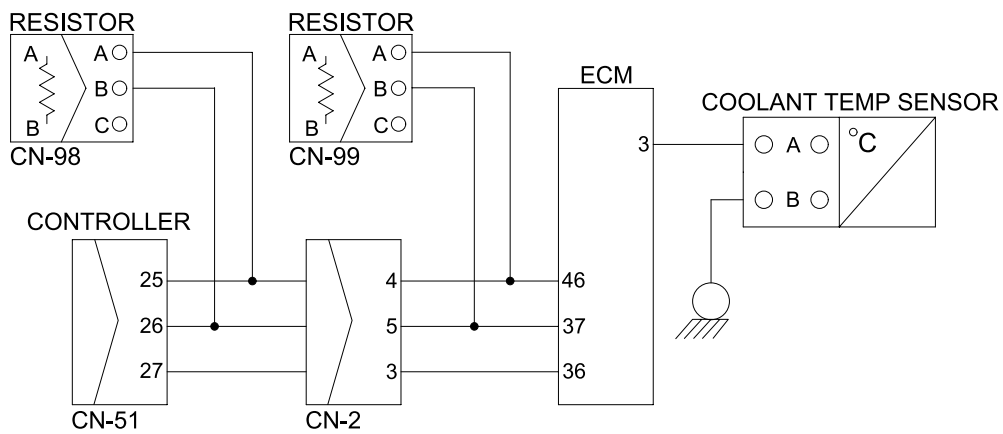

45076ES04

6. MALFUNCTION OF POWER MAX

※ Before carrying out below procedure, check all the related connectors are properly inserted.

1) INSPECTION PROCEDURE

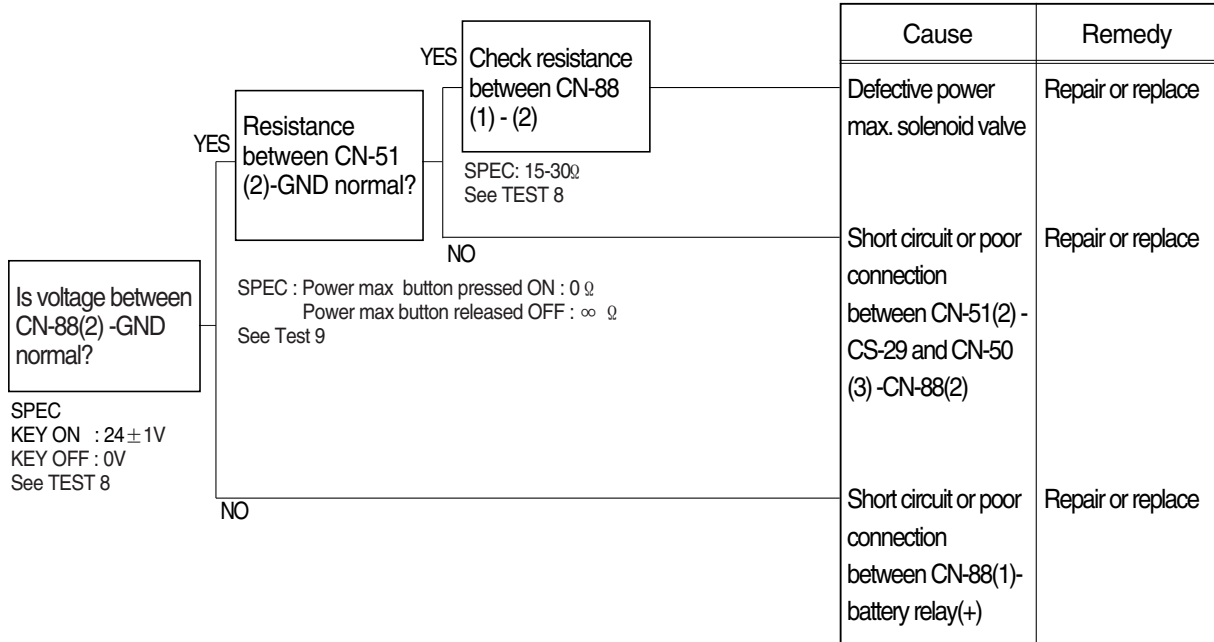

Wiring diagram

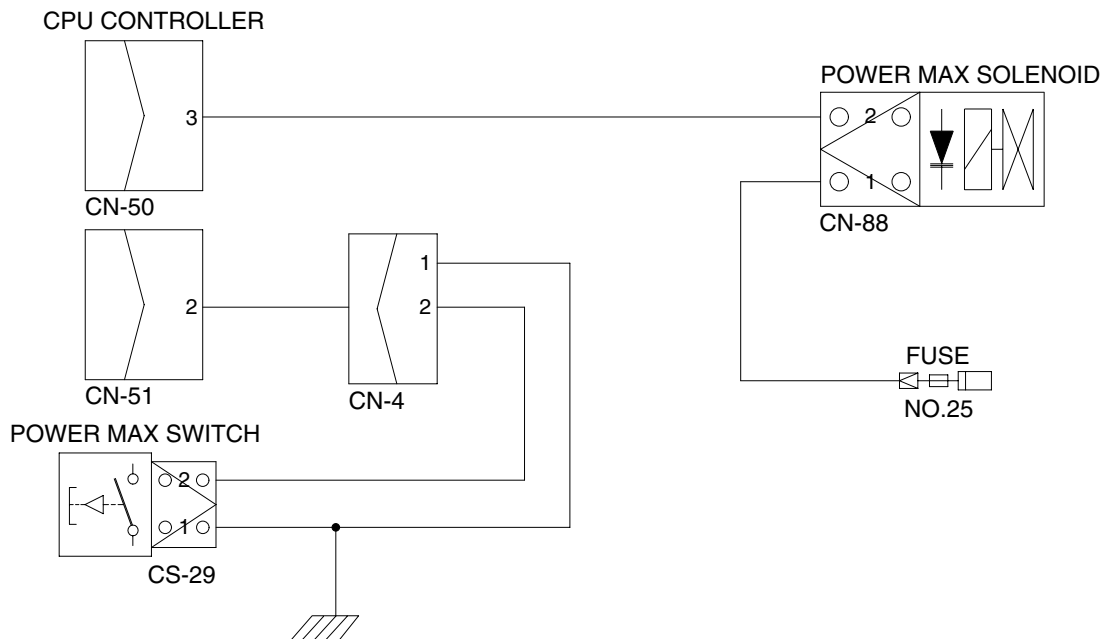

2) TEST PROCEDURE

(1) **Test 8:** Check voltage between connector CN-88 - GND.

- ① Start key ON.
- ② Disconnect connector CN-88 from power max solenoid valve.
- ③ Check voltage as figure.

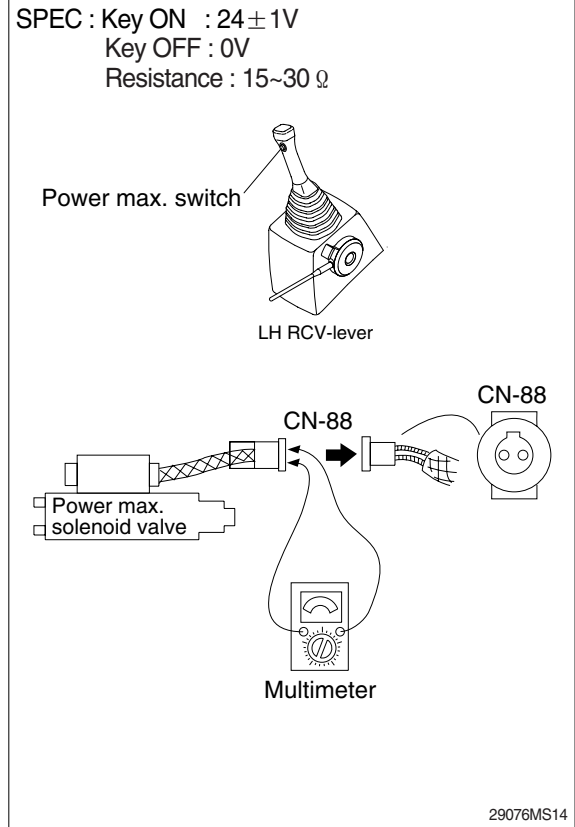

(2) **Test 9:** Check resistance between connector CN-51(2)-GND.

- ① Starting key OFF.
- ② Remove CPU controller and disconnect connector CN-51 from CPU controller.
- ③ Check resistance as figure.

