

GROUP 5 COMBINED OPERATION

1. OUTLINE

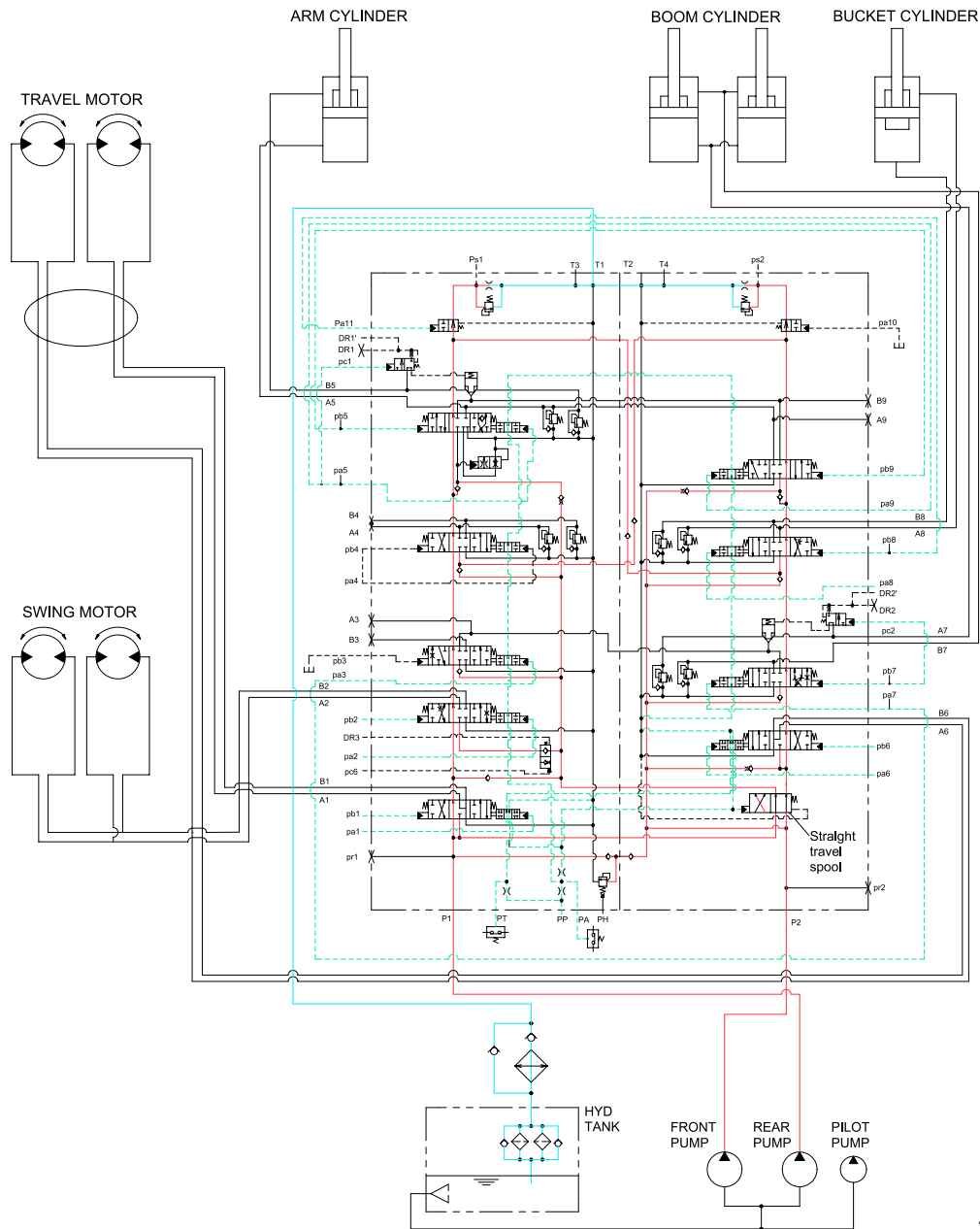

45073HC17

The oil from the front and rear pump flows through the neutral oil passage, bypass oil passage and confluence oil passage in the main control valve. Then the oil goes to each actuator and operates them. Check valves and orifices are located on these oil passage in the main control valve. These control the oil from the main pumps so as to correspond to the operation of each actuator and smooth the combined operation.

STRAIGHT TRAVEL SPOOL

This straight travel spool is provided in the main control valve.

If any actuator is operated when traveling, the straight travel spool is pushed to the left by the pilot oil pressure(PP) from the pilot pump. Consequently, the left and right travel oil supply passage are connected, and equivalent amount of oil flows into the left and right travel motors. This keeps the straight travel.

2. COMBINED SWING AND BOOM UP OPERATION(HEAVY DUTY MODE)

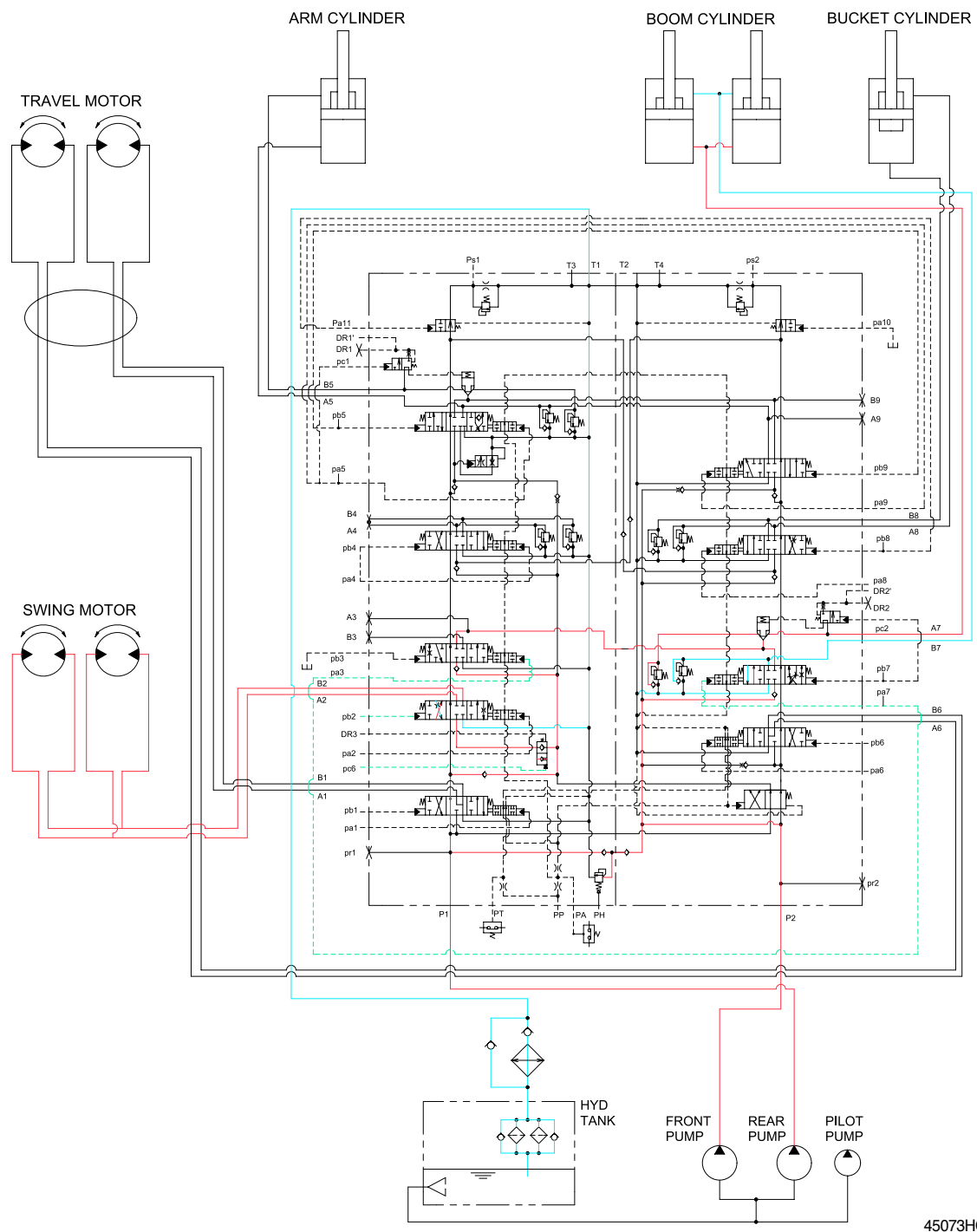

45073HC18

When the swing and boom functions are operated, simultaneously the swing and boom spools in the main control valve are moved to the functional position by the pilot oil pressure from the remote control valve. The oil from the rear pump flows into the swing motor through the swing spool. The oil from the front pump flows into the boom cylinders through the boom spool in the left control valve.

At the same time, the pressure in the boom circuits can be high while the swing pressure is low, therefore the oil from the front pump flows into the boom cylinders through boom spool via confluence oil passage by logic valve in case boom up operation.

3. COMBINED SWING AND TRAVEL OPERATION

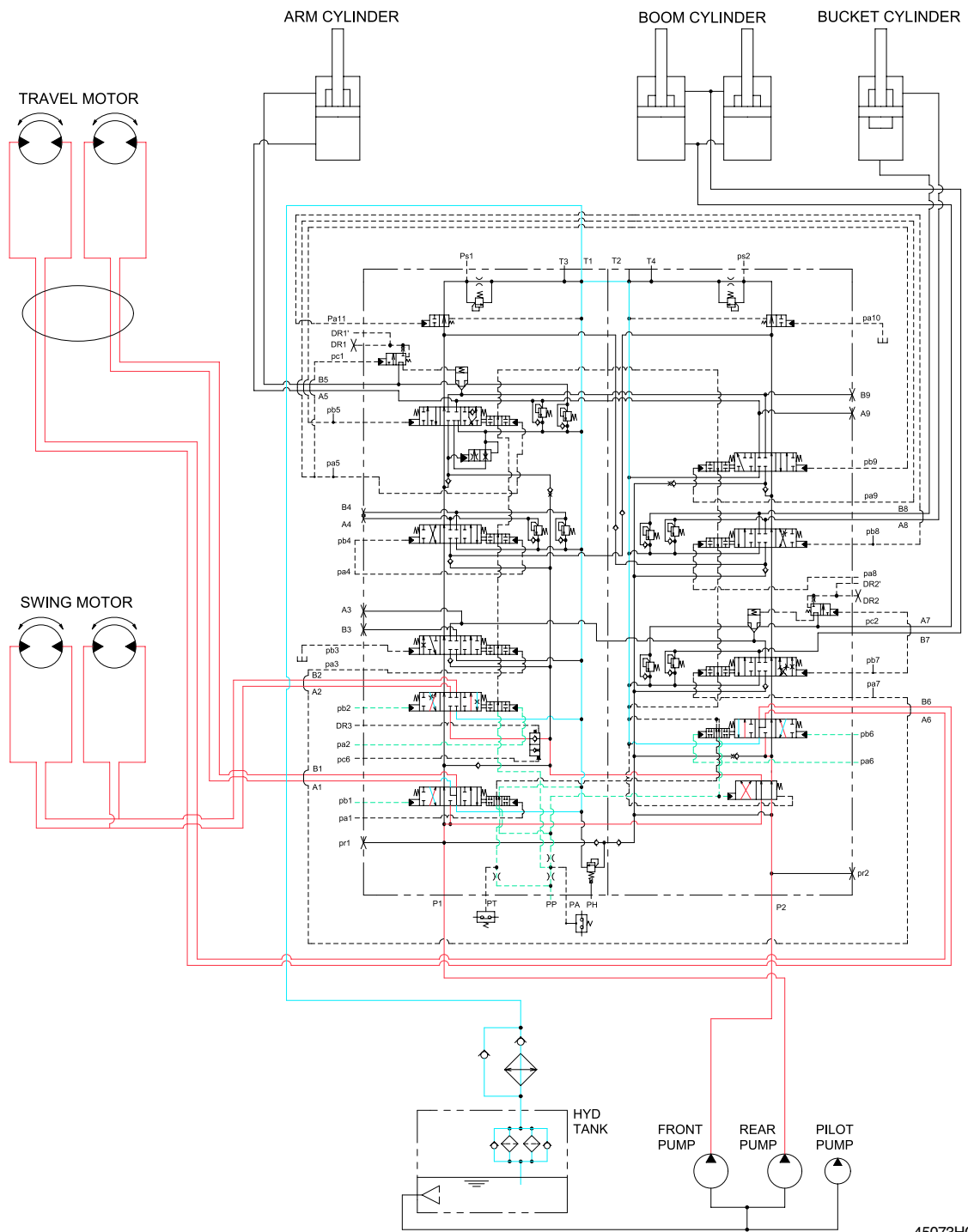

45073HC22

When the swing and travel functions are operated, simultaneously the swing spool and travel spools in the main control valve are moved to the functional position by the pilot oil pressure from the remote control valve. At the same time, the straight travel spool is pushed to the right by the pilot oil pressure(PP) from the pilot pump.

The oil from the rear pump flows into the swing motor through the swing spool. The oil from the front pump flows into the travel motors through the RH travel spool of the left control valve and the LH travel spool of the right control valve via the straight travel spool.

The superstructure swings and the machine travels straight.