

## GROUP 3 TRACK AND WORK EQUIPMENT

### 1. TRACK

#### 1) TRACK ROLLER

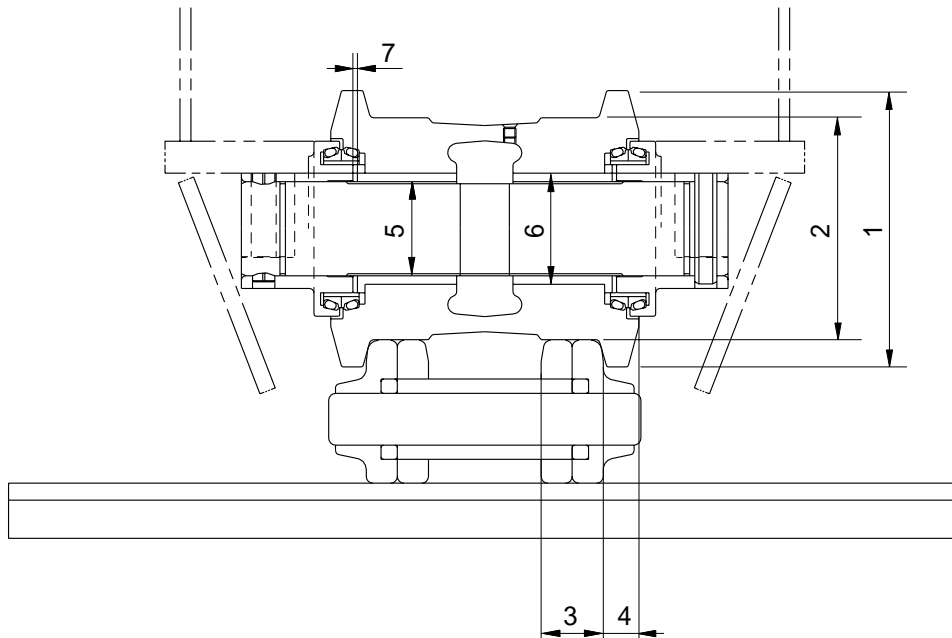

Unit : mm

No.	Check item	Criteria				Remedy
1	Outside diameter of flange	Standard size		Repair limit		Rebuild or replace
		ø 250		-		
2	Outside diameter of tread	ø 200		ø 188		
3	Width of tread	55		60.6		
4	Width of flange	35		-		
5	Clearance between shaft and bushing	Standard size	Tolerance		Standard clearance 0.29 to 0.395	Clearance limit 1.5
		ø 85	Shaft -0.25 -0.35	Hole +0.045 +0.04		
6	Interference between roller and bushing	Standard size	Tolerance		Standard Interference 0.105 to 0.07	Interference limit -
		ø 100	+0.159 +0.124	+0.054 0		
7	Side clearance of roller	Standard clearance		Clearance limit		Replace
		0.4 to 0.6		1.5		

## 2) CARRIER ROLLER

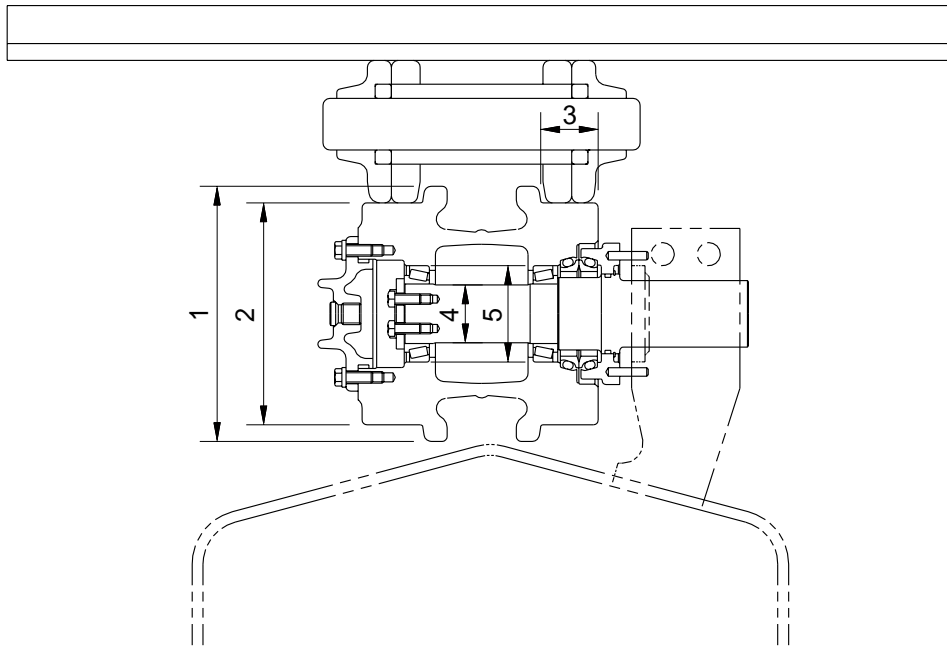

Unit : mm

No.	Check item	Criteria				Remedy	
		Standard size		Repair limit			
1	Outside diameter of flange	ø 220		-		Rebuild or replace	
2	Outside diameter of tread	ø 191		ø 181			
3	Width of tread	51		59			
4	Clearance between shaft and bearing	Standard size	Tolerance		Standard clearance	Clearance limit	Replace bushing
			Shaft	Hole			
		ø 50	+0.03 0	0 -0.15	+0.002 to +0.036	-	
5	Interference between roller and seal bushing	ø 82	0 -0.02	-0.047 -0.017	0.009 to 0.059	-	Replace bushing

### 3) IDLER

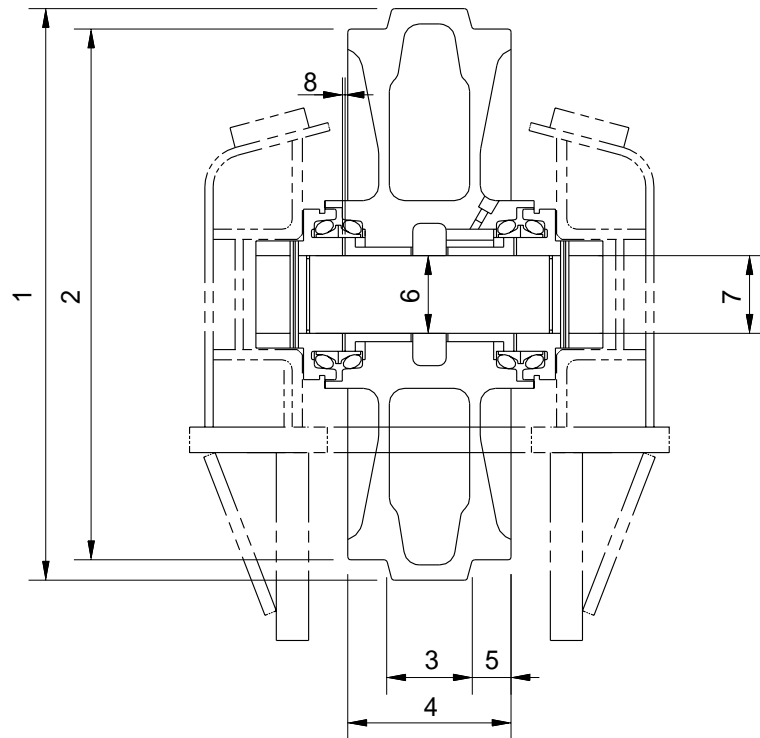

Unit : mm

No.	Check item	Criteria			Remedy	
		Standard size		Repair limit		
1	Outside diameter of protrusion	Standard size		Repair limit	Rebuild or replace	
		ø 682		-		
2	Outside diameter of tread	ø 630		ø 595		
3	Width of protrusion	102		-		
4	Total width	203		-		
5	Width of tread	50.5		55.5		
6	Clearance between shaft and bushing	Standard size & Tolerance		Standard clearance	Clearance limit	
		Shaft	Hole			
		ø 85 $\begin{matrix} 0 \\ -0.035 \end{matrix}$	ø 85.2 $\begin{matrix} +0.05 \\ 0 \end{matrix}$	0.2 to 0.24	1.5	
7	Clearance between shaft and support	ø 85 $\begin{matrix} 0 \\ -0.035 \end{matrix}$	ø 85 $\begin{matrix} -0.126 \\ -0.136 \end{matrix}$	0.036 to 0.161	0.15	Replace
8	Side clearance of idler (both side)	Standard clearance		Clearance limit		
		0.2 to 0.650		1.5		

#### 4) TRACK

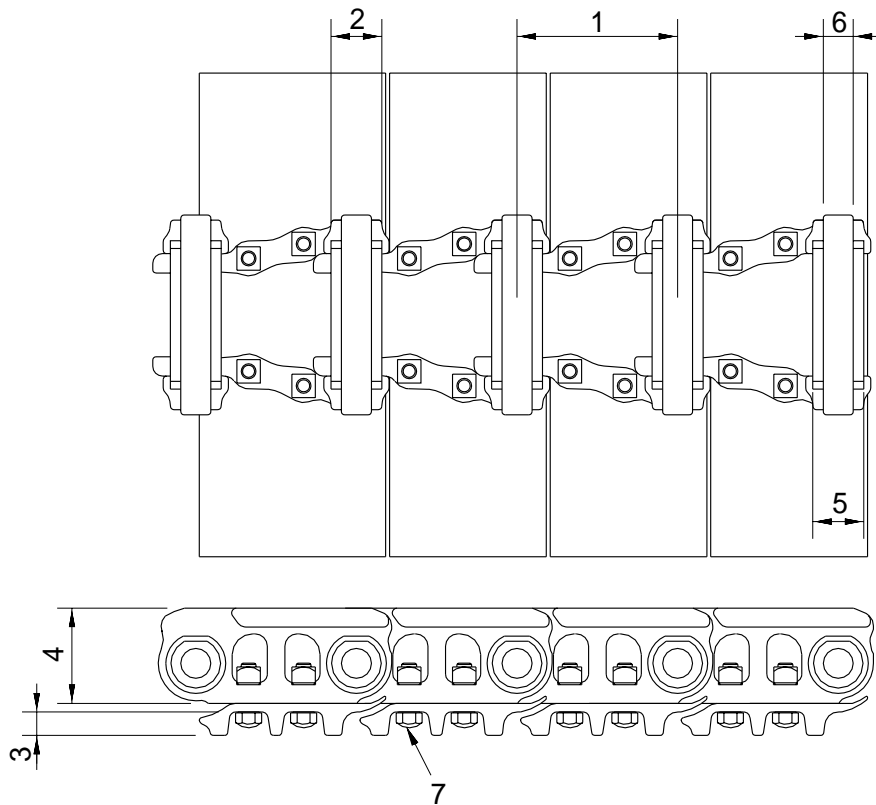

Unit : mm

No.	Check item	Criteria				Remedy
		Standard size		Repair limit		
1	Link pitch	215.9		219.9		Turn or replace
2	Outside diameter of bushing	ø 71.38		ø 66.38		
3	Height of grouser	26.5		19		Rebuild or replace
4	Height of link	125.5		115.5		
5	Interference between bushing and link	Standard size & Tolerance		Standard interference 0.380 to 0.494	Interference limit 0.100	Replace
		Shaft	Hole			
		ø 71.38 $\begin{matrix} +0.05 \\ 0 \end{matrix}$	ø 71.03 $\begin{matrix} +0.1 \\ 0 \end{matrix}$			
6	Interference between regular pin and link	ø 47.95 $\begin{matrix} 0 \\ -0.10 \end{matrix}$	ø 47.34 $\begin{matrix} +0.1 \\ 0 \end{matrix}$	0.41 to 0.61	0.190	
7	Tightening angle method (Tightening angle method)	Initial tightening torque : 86+5 kg · m Additional tightening angle : 120±10°				Retighten

## 5) TRACK FRAME AND RECOIL SPRING

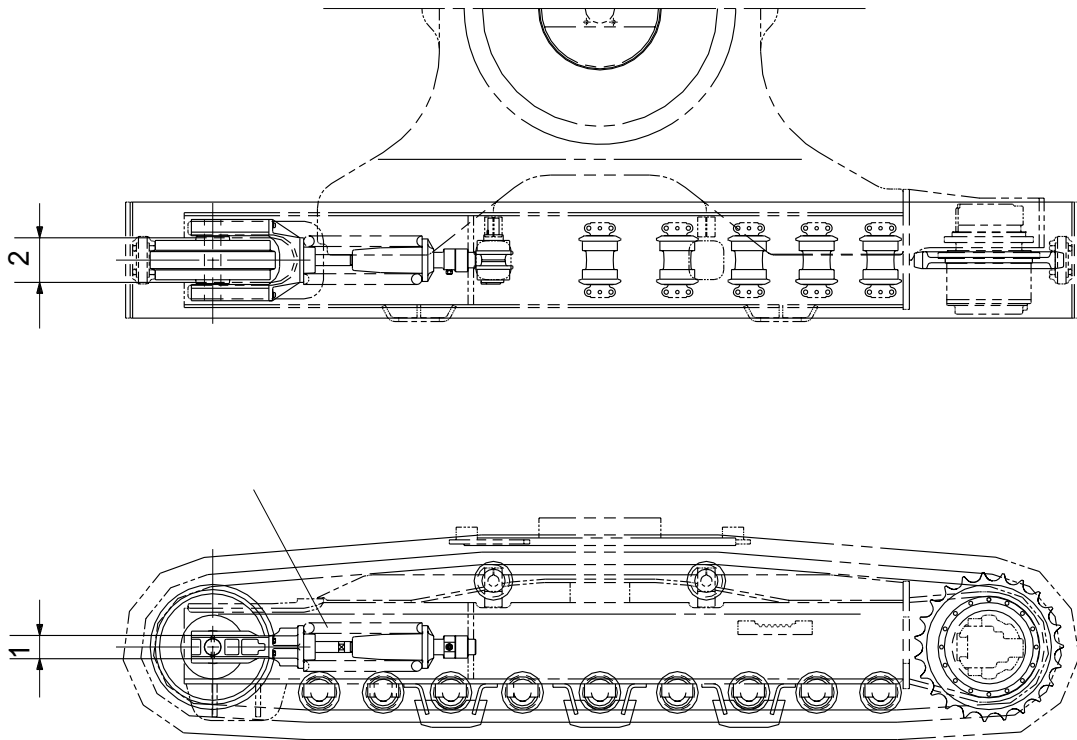

Unit : mm

No.	Check item	Criteria				Remedy	
		Item	Standard size	Tolerance	Repair limit		
1	Vertical width of idler guide	Track frame	123	+3 -1	127	Rebuild or replace	
		Idler support	120	-	116		
2	Horizontal width of idler guide	Track frame	294	+3 -1	299		
		Idler support	290	-	288		
3	Recoil spring	Standard size			Repair limit		Replace
		Free length	Installation length	Installation load	Free length	Installation load	
		∅ 193×866	690	28570kg	-	23970kg	

## 2. WORK EQUIPMENT

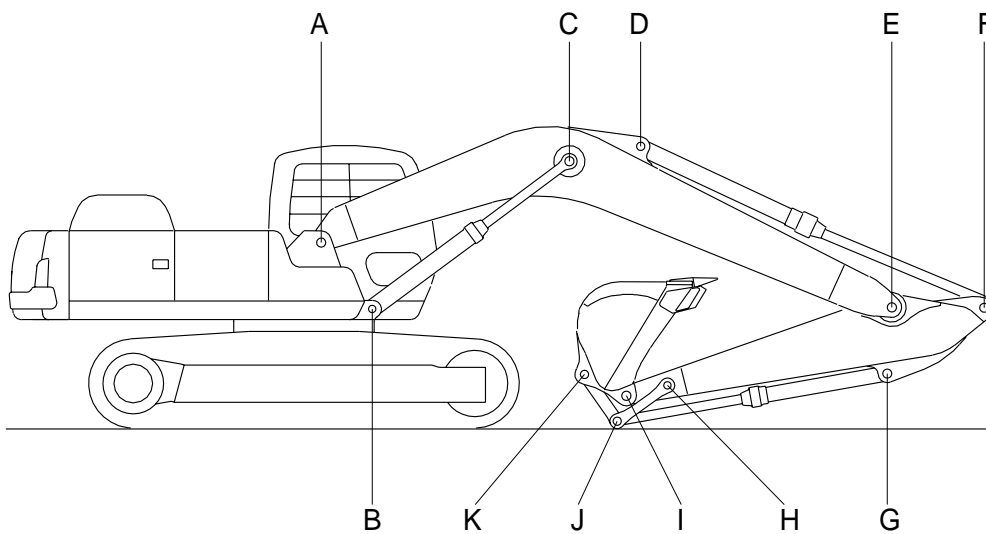

Unit : mm

Mark	Measuring point (Pin and Bushing)	Normal value	Pin		Bushing		Remedy & Remark
			Recomm. service limit	Limit of use	Recomm. service limit	Limit of use	
A	Boom Foot	120	119	118.5	120.5	121	Replace
B	Boom Cylinder Head	100	99	98.5	100.5	101	"
C	Boom Cylinder Rod	110	109	108.5	110.5	111	"
D	Arm Cylinder Head	110	109	108.5	110.5	111	"
E	Boom Top	120	119	118.5	120.5	121	"
F	Arm Cylinder Rod	110	109	108.5	110.5	111	"
G	Bucket Cylinder Head	100	99	98.5	100.5	101	"
H	Arm Link	100	99	98.5	100.5	101	"
I	Bucket and Arm Link	100	99	98.5	100.5	101	"
J	Bucket Cylinder Rod	100	99	98.5	100.5	101	"
K	Bucket Rod	100	99	98.5	100.5	101	"