

GROUP 5 SWING DEVICE

1. REMOVAL AND INSTALL OF MOTOR

1) REMOVAL

- (1) Lower the work equipment to the ground and stop the engine.
- (2) Operate the control levers and pedals several times to release the remaining pressure in the hydraulic piping.
- (3) Loosen the breather slowly to release the pressure inside the hydraulic tank.
- ▲ Escaping fluid under pressure can penetrate the skin causing serious injury.
- ※ When pipes and hoses are disconnected, the oil inside the piping will flow out, so catch it in oil pan.
- (4) Disconnect pipe assy(1, 2).
- (5) Disconnect pilot line hoses(3, 4, 5, 6, 7, 8, 9, 10, 11, 12, 13).
- (6) Sling the swing motor assembly(1) and remove the swing motor mounting bolts (14).
- Motor device weight : 197kg(434lb)
- (7) Remove the swing motor assembly.
- ※ When removing the swing motor assembly, check that all the piping have been disconnected.

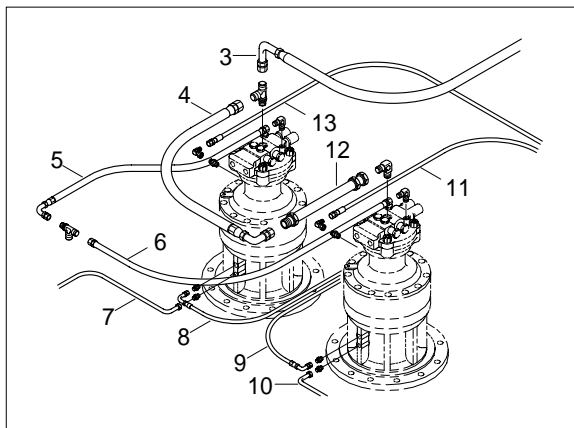
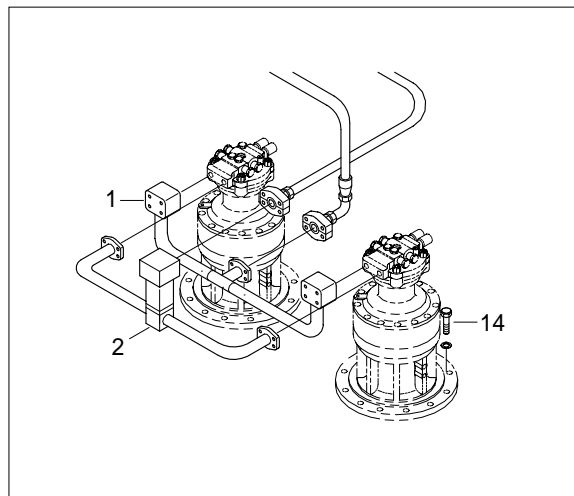

2) INSTALL

- (1) Carry out installation to the reverse order of removal.
- (2) Bleed the air from the swing motor.
 - ① Remove the air vent plug.
 - ② Pour in hydraulic oil until it overflows from the port.
 - ③ Tighten plug lightly.
 - ④ Start the engine, run at low idling, and check oil come out from plug.
 - ⑤ Tighten plug fully.
- (3) Confirmed the hydraulic oil level and check the hydraulic oil leak or not.

2. DISASSEMBLY AND ASSEMBLY OF SWING MOTOR

1) STRUCTURE

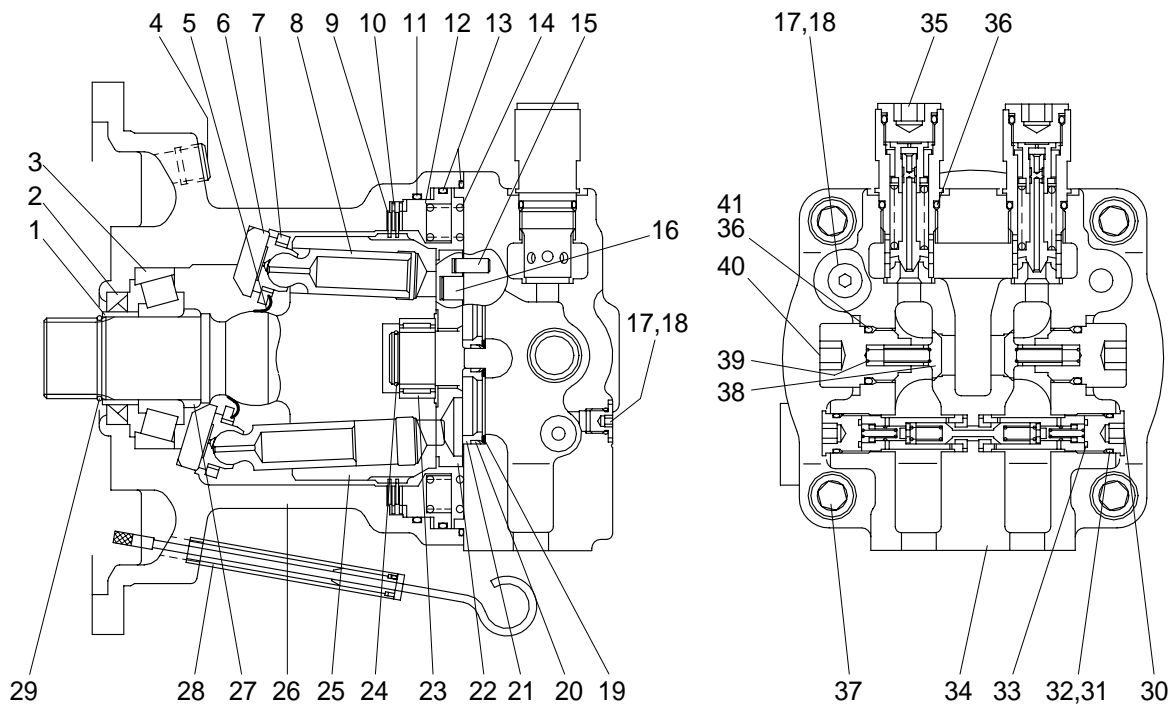

1	Inner ring	15	Parallel pin	29	Snap ring
2	Oil seal	16	Piston	30	Bypass valve assembly
3	Taper roller bearing	17	Cap	31	O-ring
4	Plug	18	O-ring	32	Back up ring
5	Backing spring	19	Coned disc spring	33	O-ring
6	Cam plate	20	Teflon ring	34	Cover
7	Return plate	21	Bushing	35	Relief valve assembly
8	Piston assembly	22	Balance plate	36	O-ring
9	Plate	23	Needle bearing	37	Hexagon socket bolt
10	Lining plate	24	Snap ring	38	Check valve
11	O-ring	25	Cylinder assembly	39	Spring
12	Piston	26	Housing	40	Cap
13	O-ring	27	Collar	41	Back up ring
14	Spring	28	Level gauge assembly		

2) DISASSEMBLY

(1) Removal of relief valve assembly

Remove cap of relief valve assembly(35) with 14mm hexagonal wrench.

※ Assemble removed relief valve assembly (35) to original state when reassembling.

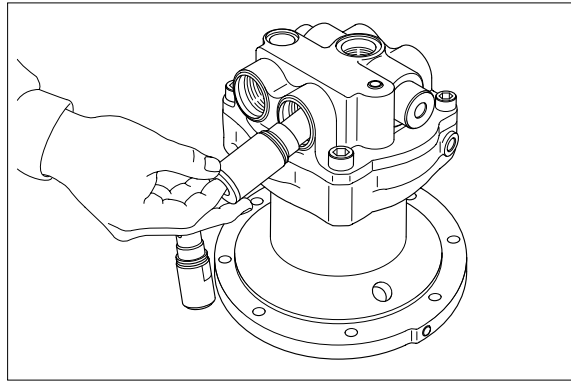

(2) Removal of make up valve

Loosen cap(40) with 14mm hexagonal wrench, and remove check valve(38) and spring(39).

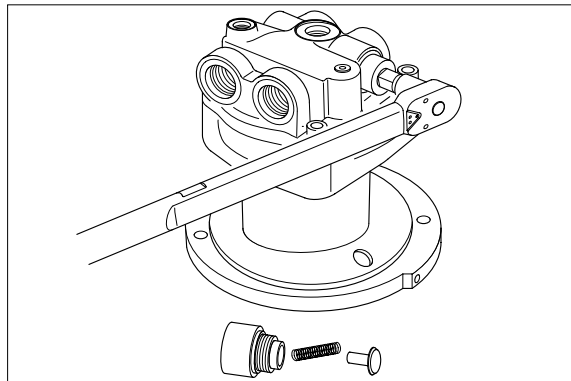

(3) Marking at swing motor

Before disassembling motor, make a matching mark between cover(34) and housing(26) for easy reassembling.

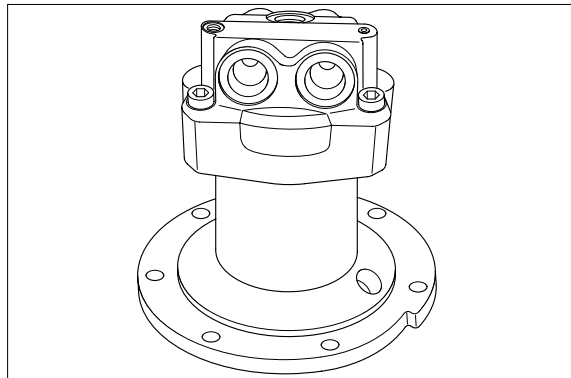

(4) Remove mounting bolts of cover

Loosen hexagon socket bolt(37) with 14mm hexagonal wrench.

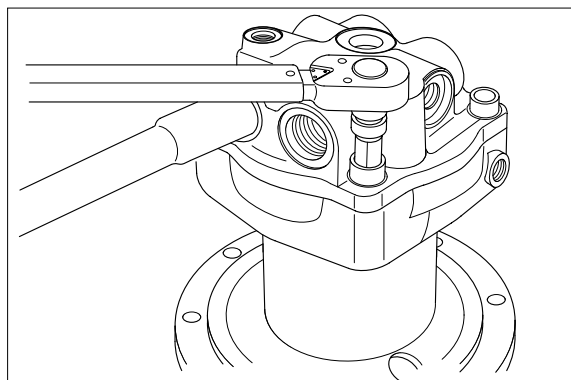

(5) Removal of cover assembly

Place shaft of motor assembly to downward and take cover(34) out.

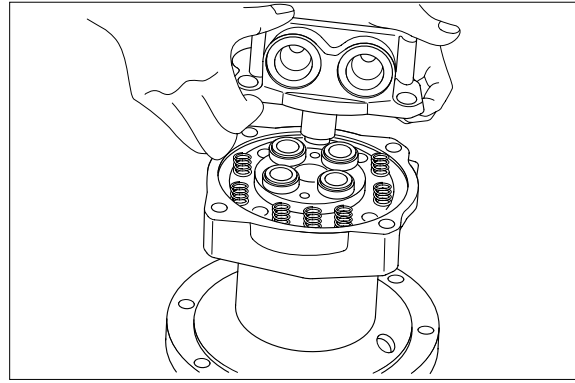

(6) Remove O-ring(13) from cover.

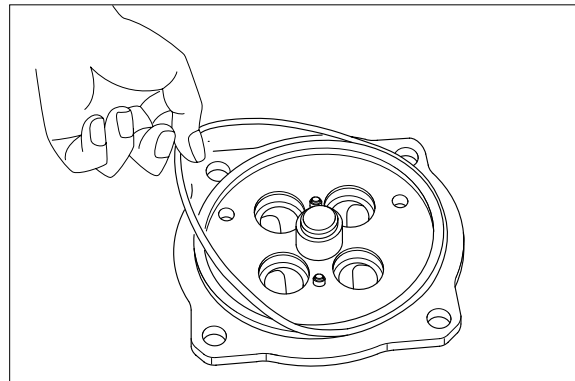

(7) Remove snap ring(24) with steel pointer and remove inner race of needle-bearing(23) by bearing puller.

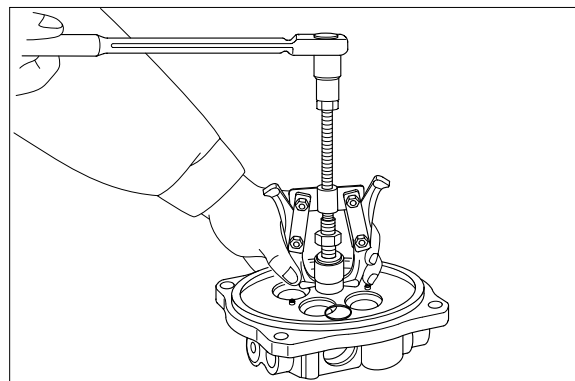

(8) Remove bushing(21) and coned disk spring(19) from teflon ring(20).

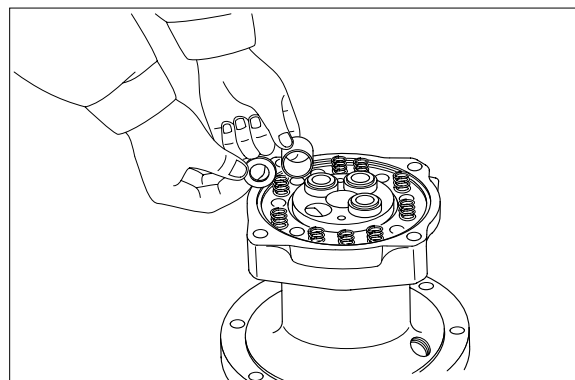

(9) Remove balance plate

Balance plate(22) is adhered on end surface of cylinder(25) by oil viscosity. Take off balance plate(22) with hands. Assembling method of balance plate(22) depends on cover(34).

(Band groove and round groove of high · low pressure transmission area)

Before removing, check and record location of balance plate(22) to prevent misassembling.

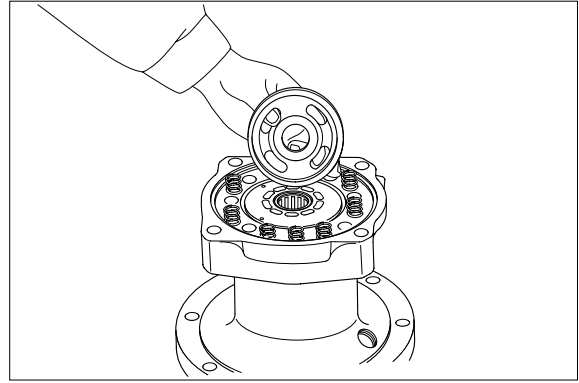

(10) Removal of spring(14, break area)

Remove spring(14) from piston(12).

Check and record original position of each spring(14) for correct assembling.

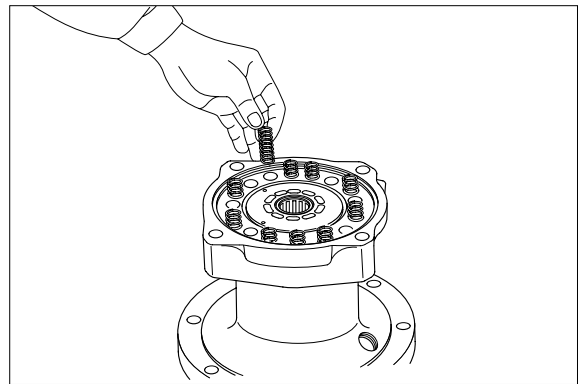

(11) Removal of brake piston

When removing piston(12) from housing (26), there is a sliding resistance against tightening of O-rings(11,13). Use tap hole(M6) on piston(12) as shown in the picture.

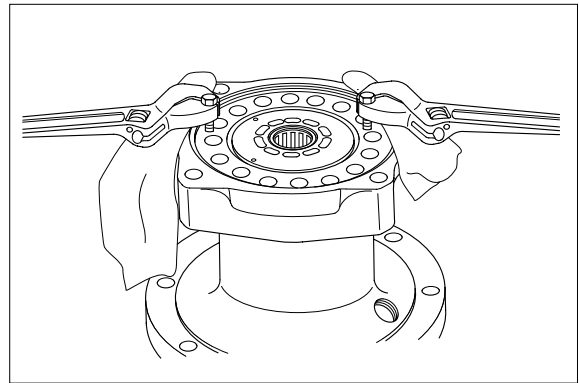

(12) Remove O-rings(11,13) from piston(12) and housing(26).

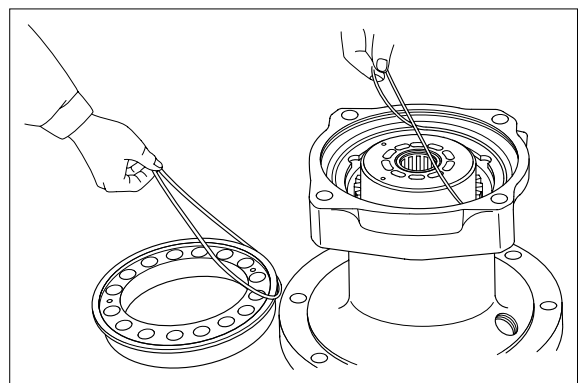

- (13) Remove friction plate(9) and lining plate(10) from housing(26).

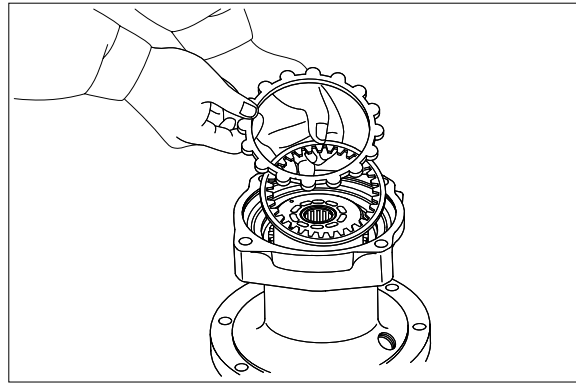

(14) Removal of cylinder assembly

Holding end of cylinder assembly(25) with hand, draw out cylinder assembly from housing.

- ※ Oil seal(2) and outer race of taper roller bearing(3) are left inside of housing.
- ※ End surface of cylinder(25) is sliding face . So, protect the surface with a scrap of cloth against damage.
- ※ Make a matching mark on piston hole of cylinder(25) and piston assembly(8) to fit piston into the same hole when reassembling.

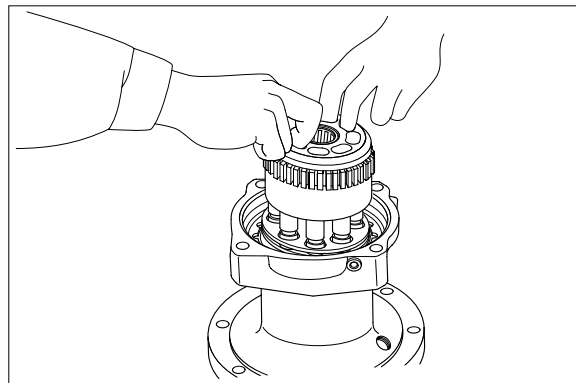

- (15) Separate outer race of taper roller bearing(3) from housing.

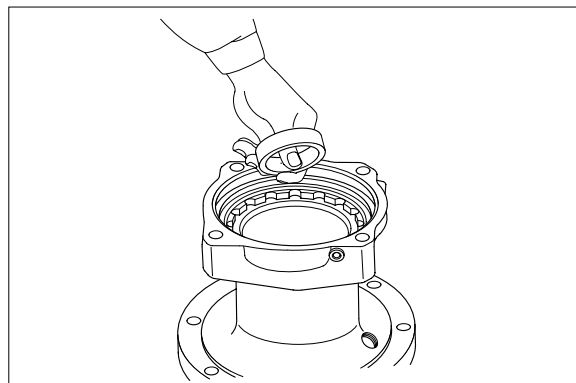

(16) Removal of oil seal

Remove oil seal(2) from housing(26) with driver and hammer.

- ※ Do not reuse oil seal after removal.

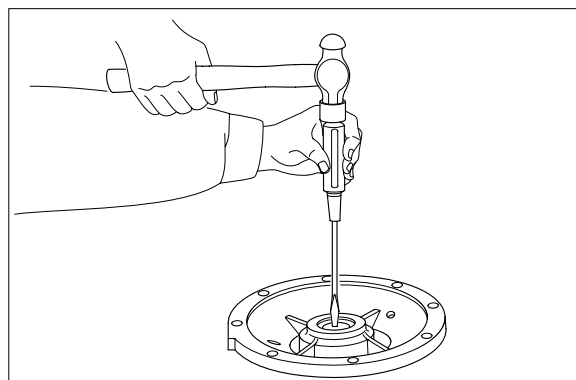

(17) Disassembly of cylinder assembly

- ① Removal of inner race of taper roller bearing(3).

After removing snap ring(29), lift out cylinder(25) with 2 inner race of roller bearing(3) by applying gear puller at the end of spline in the cylinder.

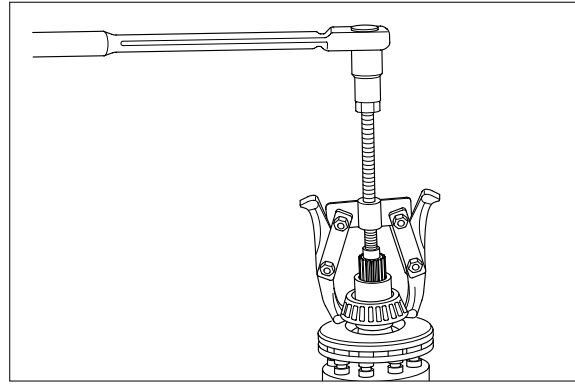

- ② Separate cam plate(6), piston assembly(8), return plate(7) from cylinder(25).

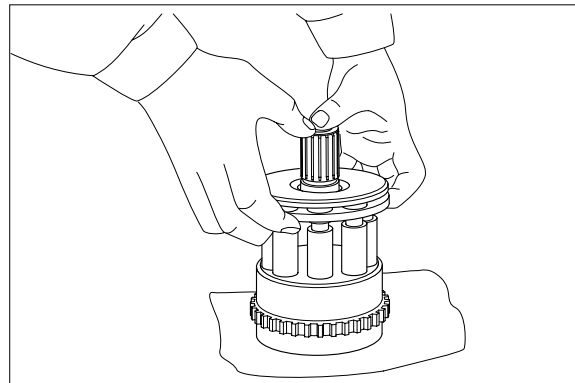

- ③ Get cam plate(6) slide on sliding face of piston assembly(8) and remove it.

※ Be cautious not to damage on sliding face of cam plate.

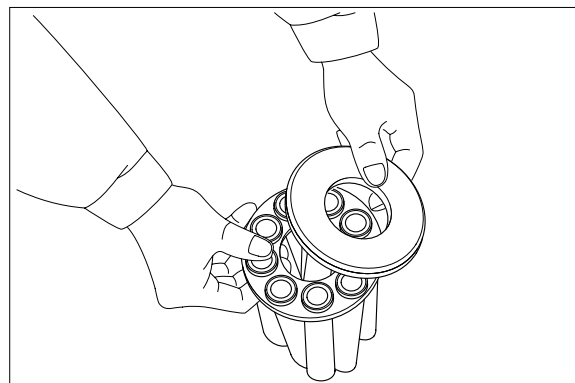

- ④ Remove backing spring(5) from cylinder(25).



This completes disassembly.

3) ASSEMBLY

(1) Preparation

Before reassembling, perform below procedure.

- ① Check each part for damage caused by using or disassembling. If damaged, eliminate damage by grinding with proper sandpaper, wash them with cleaning oil and dry with compressed air.
- ② Replace seal with new one.
- ③ Grind sliding face of piston assembly (8), balance plate(22) and cam plate(6) with sandpaper #2000.

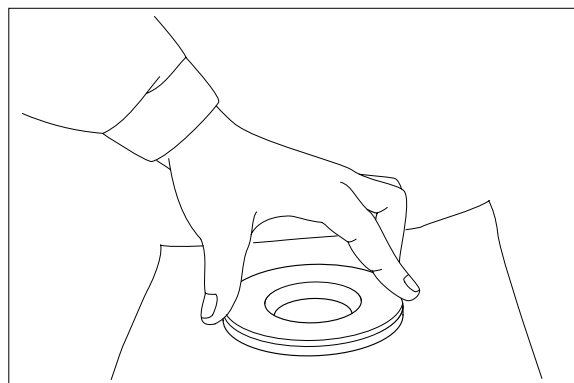
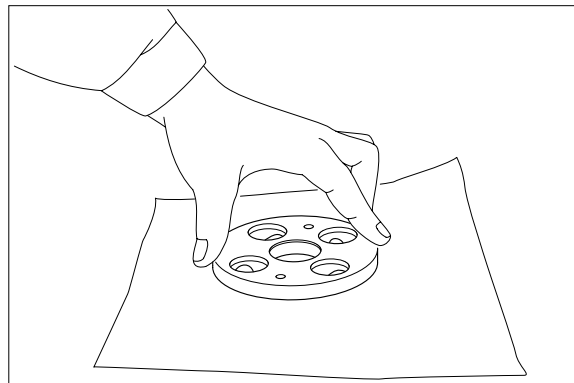
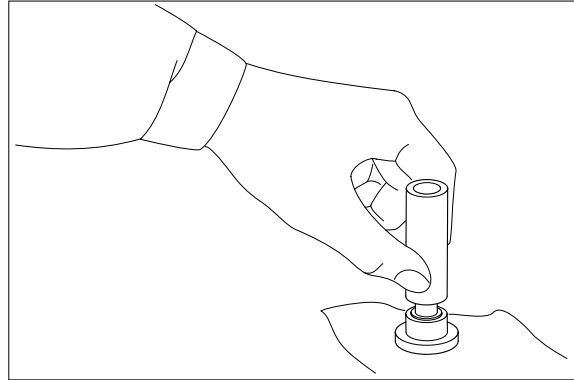

- ④ When assembling, lubricate with specified clean hydraulic oil.
- ⑤ When assembling piston assembly(8) to piston hole of cylinder(25), check matching mark between them.

(2) Assembly of cylinder assembly

- ① Lubricate grease on round area (contacting area with spring(5)) of cylinder(25) and assemble spring(5).

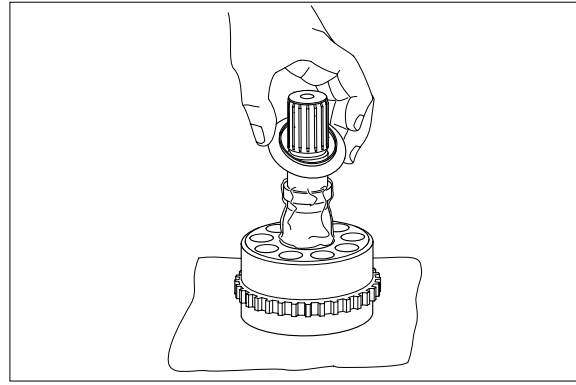

- ② Insert piston assembly(8) in hole of return plate(7).

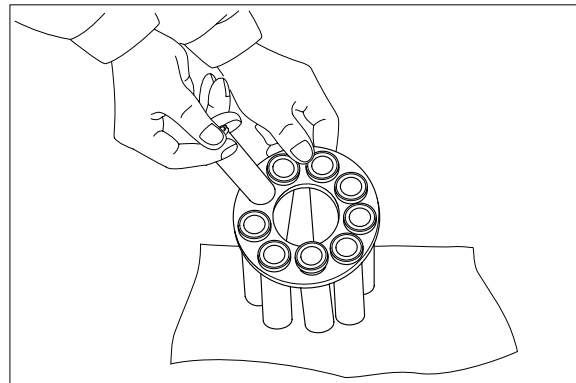

- ③ Assemble piston assembly(8) and return plate(7) to cylinder(25). When assembling, check matching mark between them. Before assembling, lubricate specified hydraulic oil in piston hole of cylinder(25).

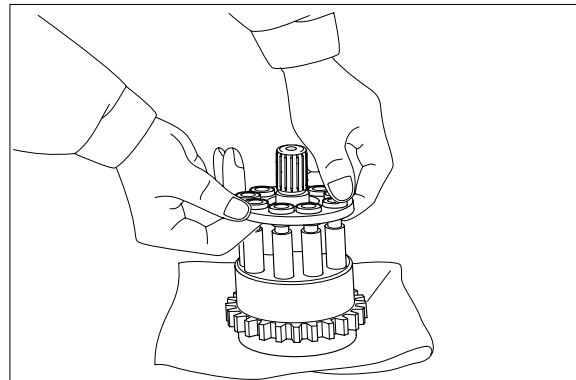

- ④ Lubricate specified hydraulic oil on shoe sliding face of piston assembly(8) and assemble cam plate(6).

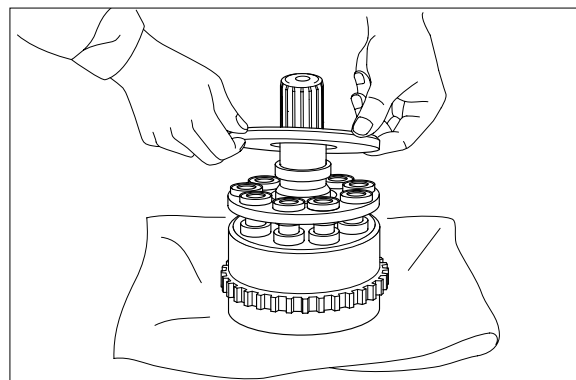

- ⑤ Assemble inner race of taper roller bearing(3) to cylinder(25).

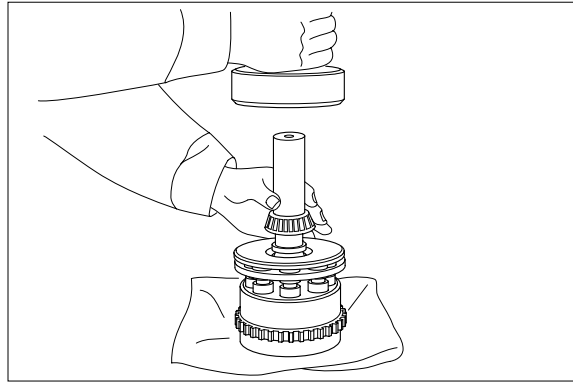

- ⑥ Apply loctite to bearing mounting area of inner race of cylinder(25) lightly.

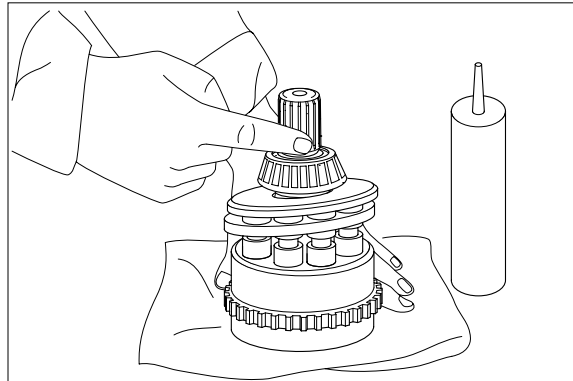

- ⑦ Assemble inner race(1) to cylinder(25).

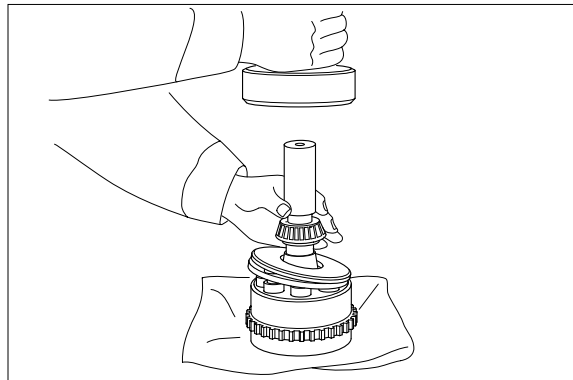

(3) Assembly of oil seal

Apply three bond of white color on outer surface of oil seal(2) and assemble and insert it.

- ※ Before assembling, lubricate lip of oil seal with grease.

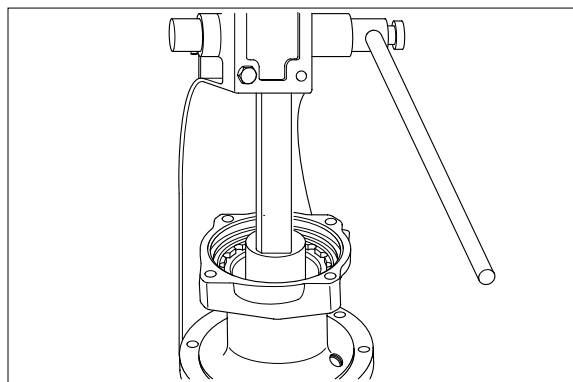

- (4) Assemble outer race of taper roller bearing(3) to motor housing(26).

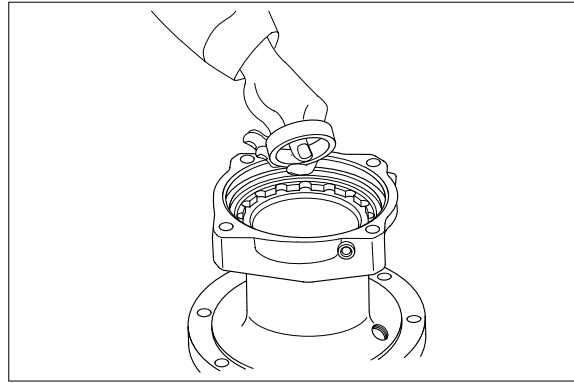

(5) Assembly of cylinder assembly

Hold end of cylinder assembly(25) with hands and assemble cylinder assembly to housing(26). Be careful to prevent damage of seal by spline of shaft.

- ※ When assemble cylinder assembly, spline shaft of cylinder is protruded from end of housing, therefore put pads with length 30~50mm under bottom of

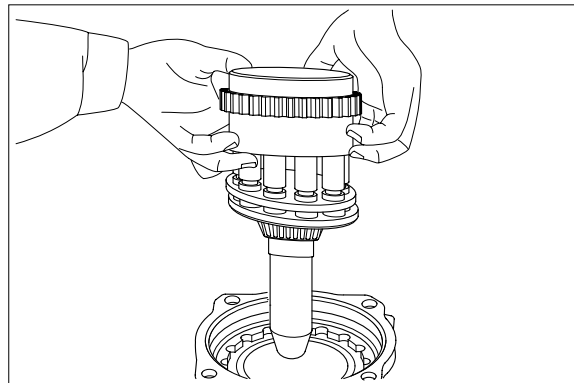

- (6) Assemble plate(9) and lining plate(10).

- ※ Lubricate specified hydraulic oil on each side.

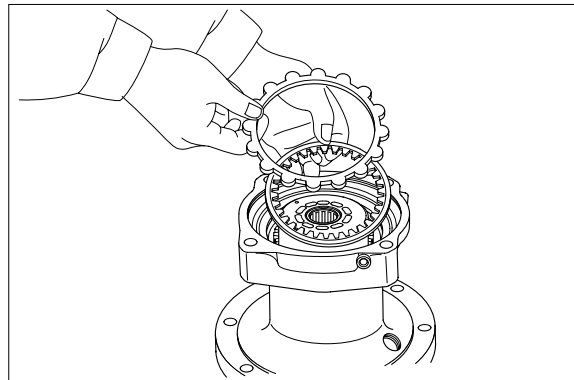

- (7) Insert O-rings(11,13) into housing(26) and piston(12).

- ※ Lubricate O-ring with grease.

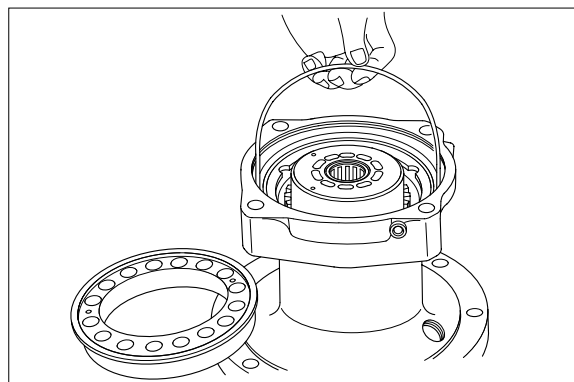

(8) Assembly of brake piston

Lubricate specified hydraulic oil on outer sliding face of piston(12) and assemble brake piston to housing(26).

- ※ It is too tight to assemble piston(11) because O-rings(11,13) are fitted, therefore it is recommended to push piston(12) horizontally by hands at once.

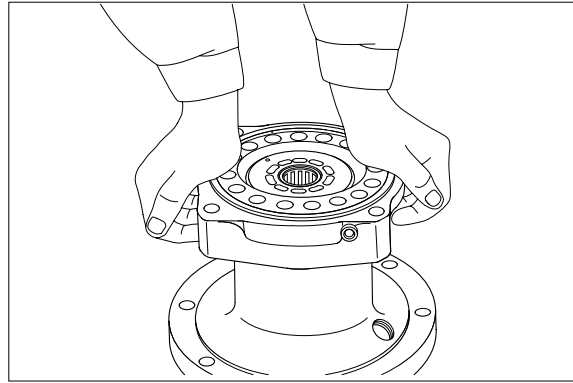

(9) Assembly of spring(14, brake unit)

Assemble spring(14) to piston(12) of brake unit.

- ※ Insert spring(14) into original position.

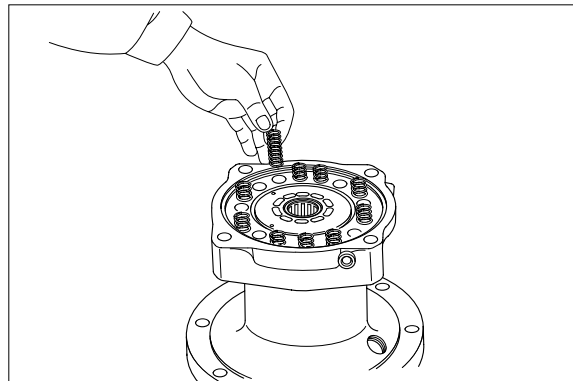

- (10) Assemble inner race of needle bearing (23) and snap ring(24) to cover(34).

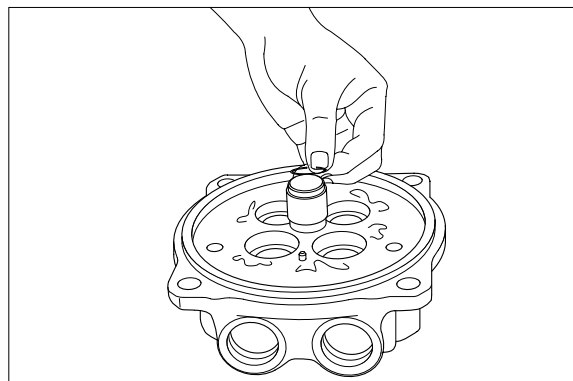

- (11) Assemble bushing(21) with teflon ring(20) and coned disk spring(19) to bushing hole of cover(34).

- ※ Lubricate on both end surfaces of bushing(21) and outer face of teflon ring(20) with grease and assemble cover to housing, and parts are adhered on cover by grease viscosity which makes assembling easy.

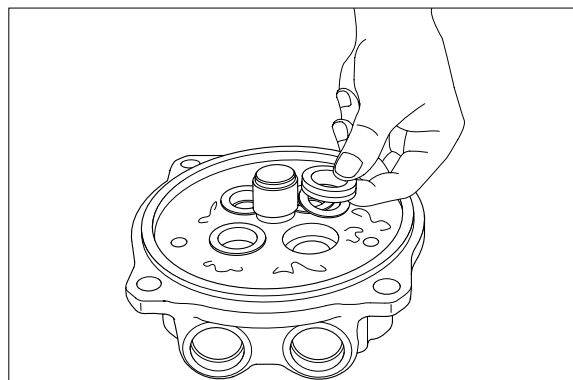

- (12) Lubricate locating pin for antirotation of balance plate(22) of cover(34) with grease sufficiently and install locating pin to housing.

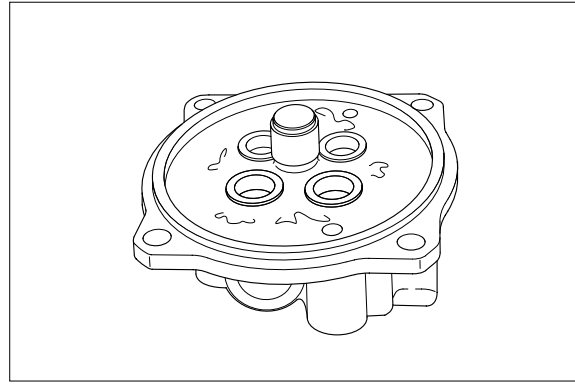

(13) Assembly of balance plate

Assemble balance plate(22) to cover(34).

- ※ Be cautious of assembling direction.

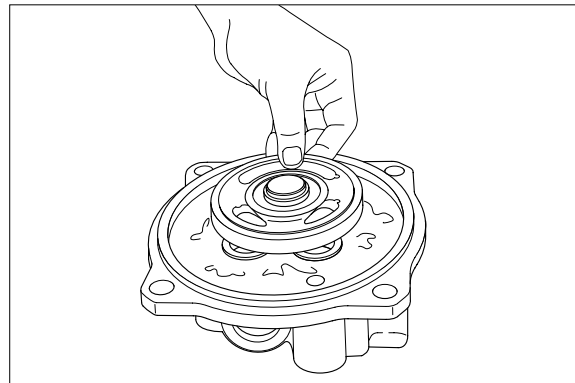

- (14) Assemble O-ring(13) to cover(34).

- ※ Lubricate O-ring with grease.

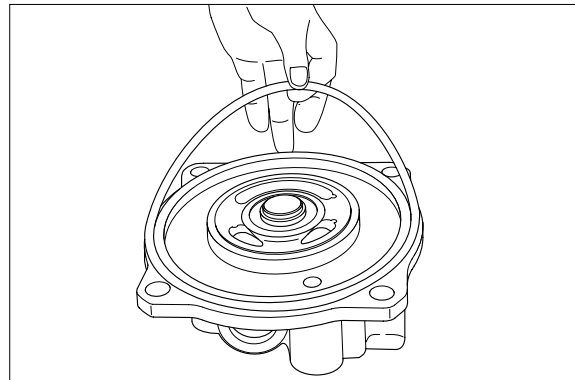

- (15) Apply three bond of white color to distinguish oil leakage from remaining oil in bolt hole(M16) of cover(34).

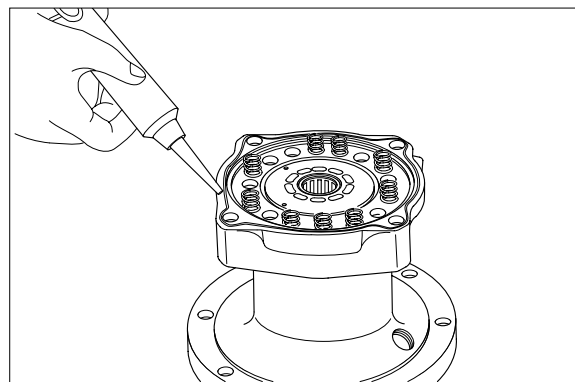

(16) Assembly of cover

Assemble cover(34) and balance plate (22) to housing(26) lightly, holding them up with hands.

- ※ When assembling, be careful not to detach balance plate(22) and bushing (21) from cover(34).
- ※ Fit matching marks on housing(26) and cover(34) made before disassembling.

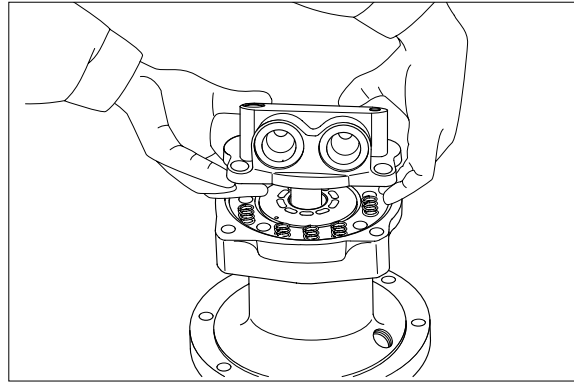

(17) Tighten cover(34) and housing(26) with 16mm hexagonal socket bolt(37).

- Tightening torque : 29kgf · m
(210 lbf · ft)

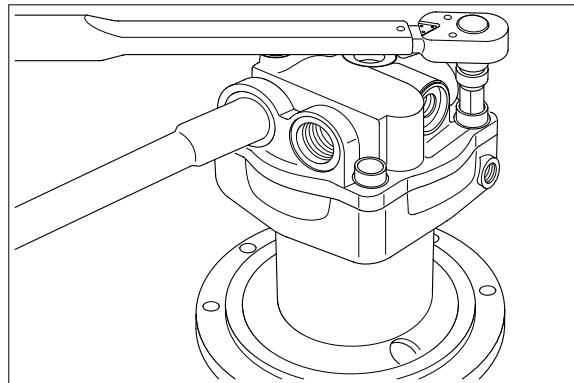

(18) Assembly of make up valve

Assemble check(38) and spring(39) to cover(34) and tighten cap(40) with 14mm hexagonal socket bolt.

- Tightening torque : 14kgf · m
(101lbf · ft)

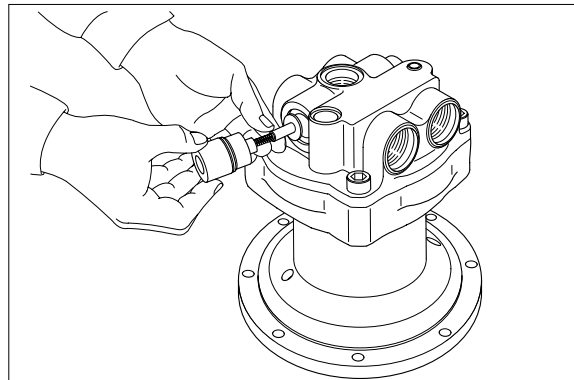

(19) Assembly of relief assembly

Assemble relief valve assembly(35) to cover(34) with 14mm hexagonal socket bolt.

- Tightening torque : 8kgf · m
(58lbf · ft)

- ※ Be cautious of assembling method.

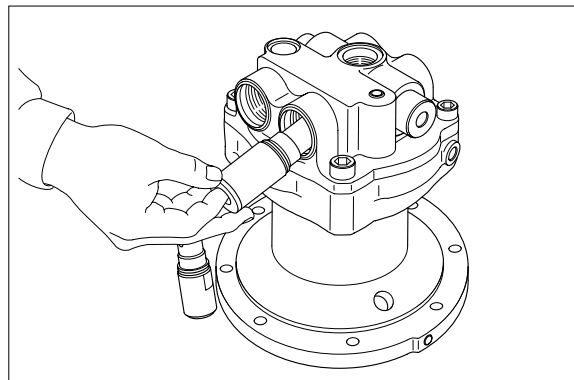

(20) Check of assembly

Load pilot pressure of 30kgf/cm^2 to brake release port after opening inlet and outlet port.

Check if output shaft is rotated smoothly around torque of $2\sim 3\text{kgf} \cdot \text{m}$.

If not rotated, disassemble and check.

This completes assembly.

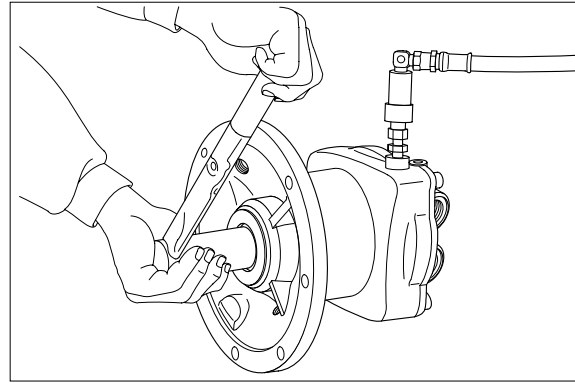

3. REMOVAL AND INSTALL OF REDUCTION GEAR

1) REMOVAL

- (1) Remove the swing motor assembly.
For details, see **removal of swing motor assembly**.
- (2) Slide reduction gear assembly(1) and remove mounting bolts(2).
- (3) Remove the reduction gear assembly.
 - Motor device weight : 197kg(434lb)
 - Tightening torque : $57.9 \pm 8.7 \text{kgf} \cdot \text{m}$
($418 \pm 62.9 \text{lbf} \cdot \text{ft}$)



2) INSTALL

- (1) Carry out installation in the reverse order to removal.

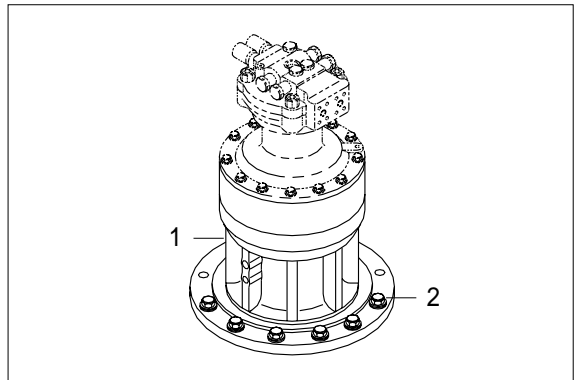

4. DISASSEMBLY AND ASSEMBLY OF REDUCTION GEAR

1) STRUCTURE

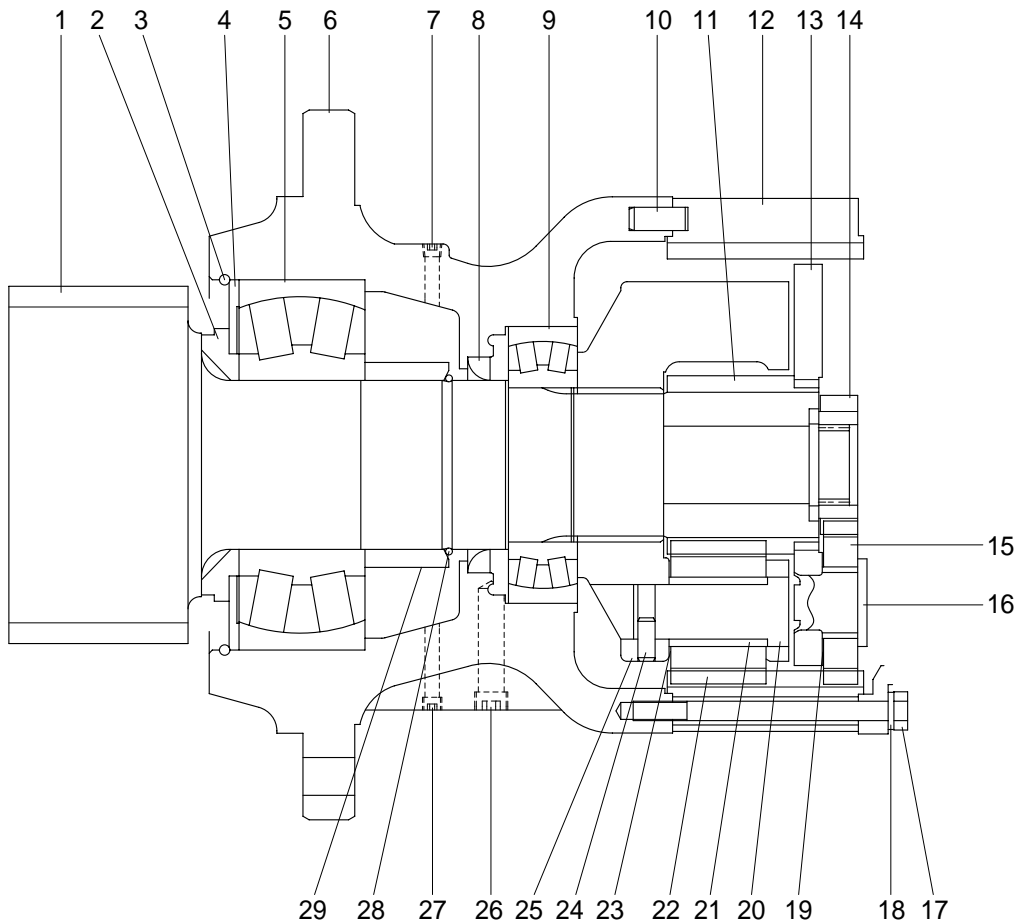

1	Pinion shaft	11	Spur gear 4	21	Bushing
2	Collar	12	Ring gear	22	Planetary gear 5
3	Snap ring	13	Holder assy 1	23	Thrust plate
4	Plate	14	Sun gear	24	Spring pin
5	Roller bearing	15	Planetary gear 2	25	Holder assy 2
6	Gear casing	16	Shaft assy 1	26	Plug
7	Plug	17	Bolt	27	Plug
8	Oil seal	18	Lock washer	28	Snap ring
9	Roller bearing	19	Thrust plate	29	Collar
10	Parallel Pin	20	Shaft assy 2		

2) DISASSEMBLY

(1) Removal of sun gear and 1st holder assembly

Remove sun gear(14) and holder assembly1(13) itself.

- ※ Shaft 1(16) is pressed into holder(13) and tighten by press. Therefore, it is impossible to disassemble any more. Please replace assembly(13, 15, 16, 19) if they have defect.

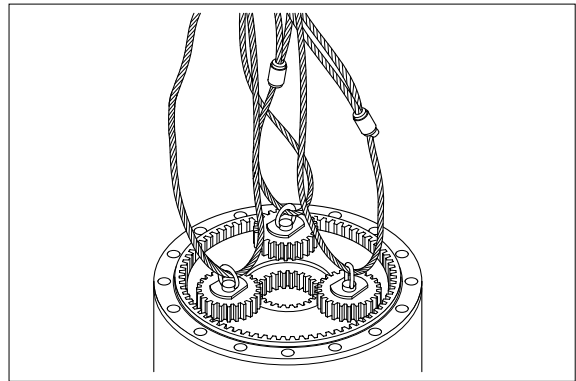

(2) Removal of planetary gear 4 and 2nd holder assembly

Remove planetary gear 4(11) and holder assembly 2(25) itself.

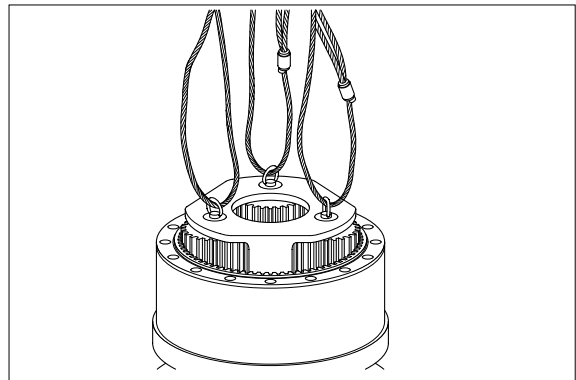

(3) Disassembly of 2nd holder assembly

- ① Insert spring pin(24) into shaft 2(20) by hammering.

- ※ Do not reuse spring pin after removal.

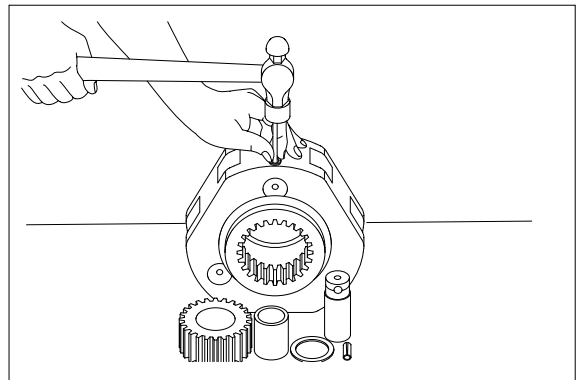

- ② Remove shaft 2(20) from holder 2(25), planetary gear 5(22) with hands.

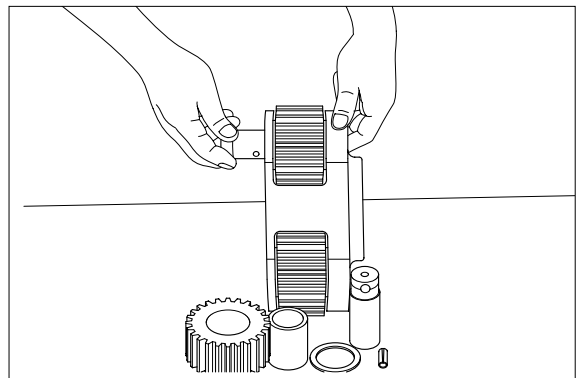

(4) Removal of ring gear

- ① Remove ring gear(12) from casing(6).
- ※ Fluid packing is applied on contacting face of ring gear and gear casing. Therefore, remove ring gear through tap hole of gear casing with (-) driver.

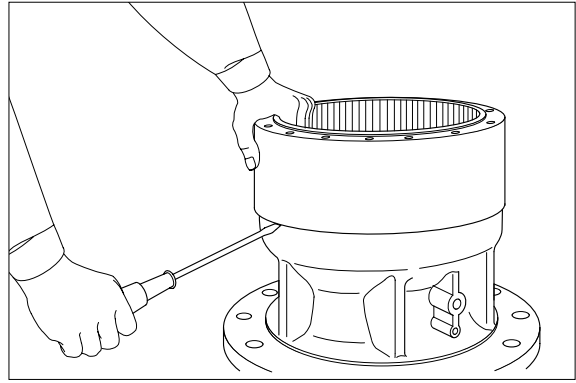

(5) Removal of pinion shaft assembly

- ① Remove snap ring(3) through hole of gear casing with (-)driver.

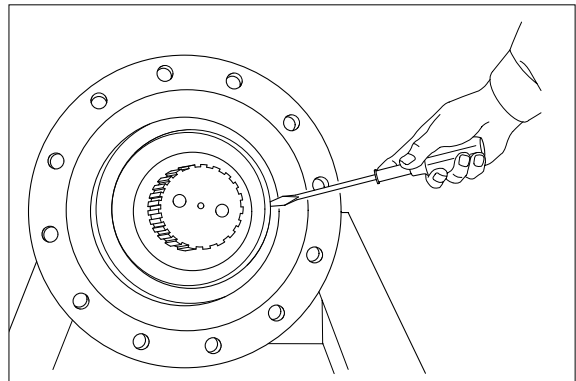

- ② Press end face of pinion shaft(1) with hydraulic press to gain space(approx. 300mm) needed for removing pinion shaft at flange part of gear casing, and remove pinion shaft(1), collar(2), plate(4), roller bearing(5) as assembly.
Do not reuse oil seal(8) after removal.

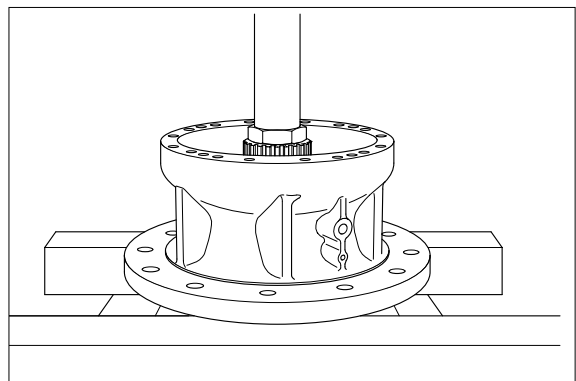

- ③ Remove roller bearing(9) from gear casing(6).

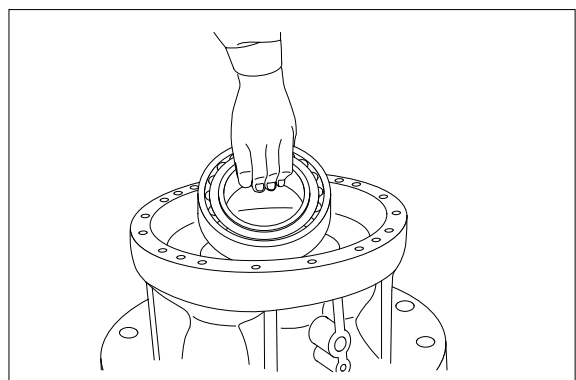

- ④ Remove oil seal(8) from gear casing(6).

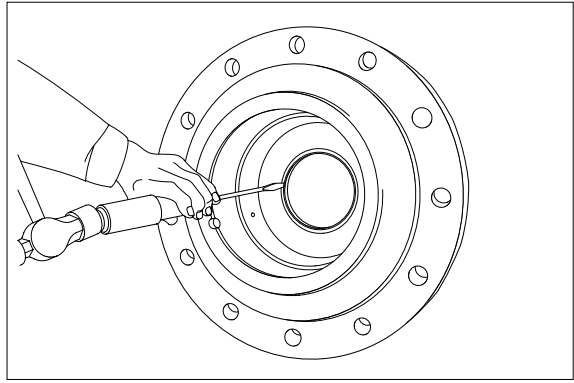

(6) Disassembly of pinion shaft assembly

- ① Remove snap ring(28) from pinion shaft(1) with scribe and then remove collar(29).
※ Be cautions not to damage on sliding face of oil seal lip of pinion shaft.

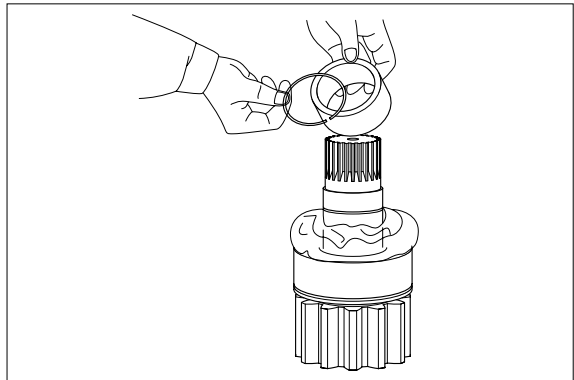

- ② Remove roller bearing(5), plate(4) and collar(2) by pressing output pinion shaft and end face of the other side.
※ Replace pinion shaft assy if they have defeat.

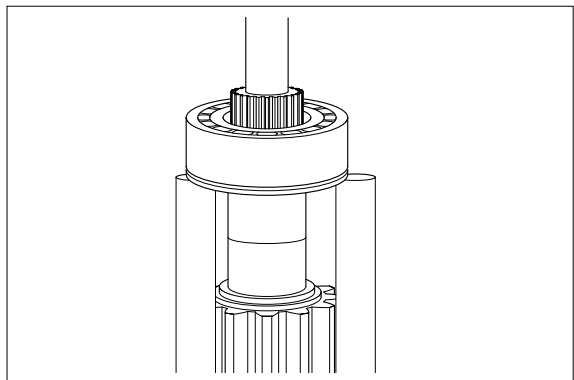

This completes disassembly.

3) ASSEMBLY

(1) Assembly of pinion shaft assembly

- ① Insert collar(2) into pinion shaft(1) and assemble plate(4).
※ Be cautious of assembling direction.

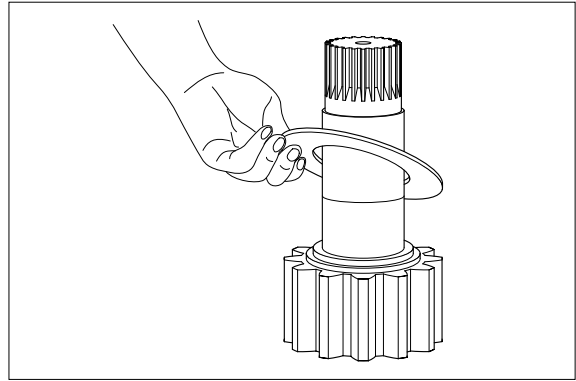

- ② Heat roller bearing(5) up to 50°C plus surrounding temperature and assemble it to pinion shaft(1).
※ Heat roller bearing up more than 100°C.

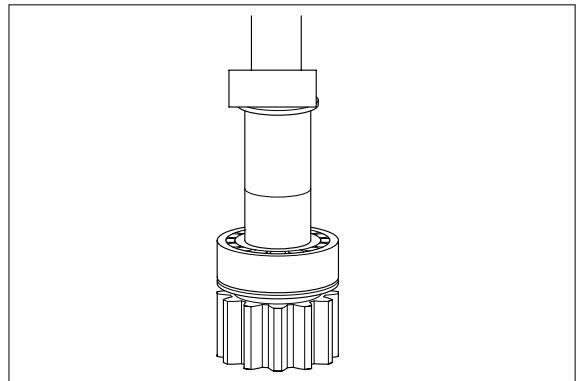

- ③ Assemble collar(29) and snap ring(28).
※ Be cautions of assembling direction.

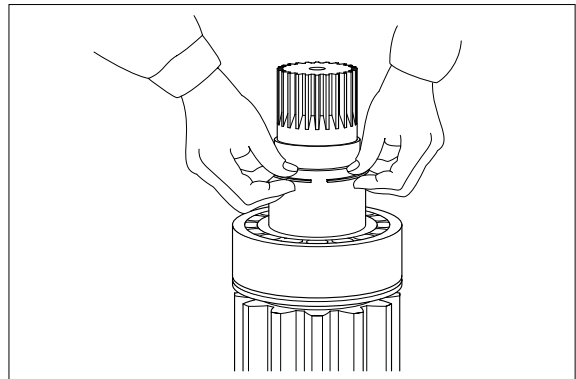
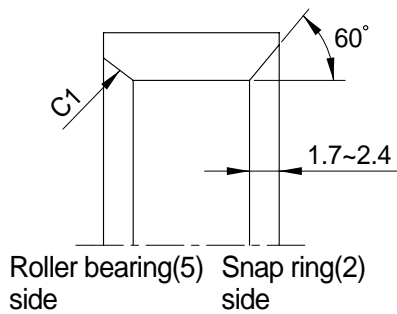

- ④ Lubricate on outer face of roller bearing(5) with grease.
Capacity : 400cc

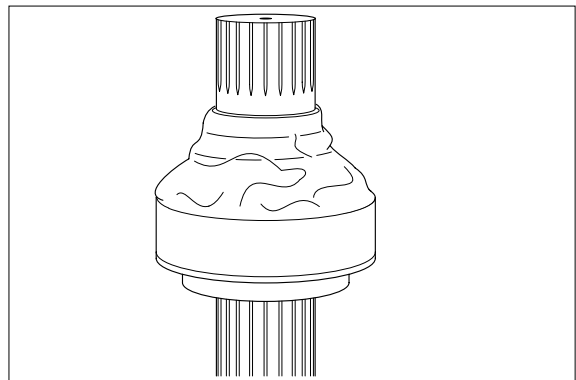

(2) Installation of oil seal

Remove oil from assembled face of oil seal of gear casing(6) and oil seal(8). Apply fluid packing(three bond of white color) on outer face of oil seal and assemble at pressing jig of gear casing. After inserting with press, lubricate on oil seal lip with grease.

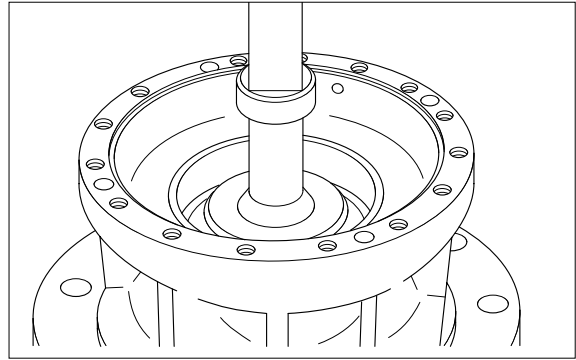

(3) Assembly of pinion shaft assembly

- ① Be careful lest oil seal lip damage by spline of pinion shaft(1).

Assemble pinion shaft assembly by using seal guide.

- ② Put pinion shaft of gear casing(6) upward.
Assemble pinion shaft assembly to gear casing by tightening eye bolt into tap hole(M16) of output side of pinion shaft(1).

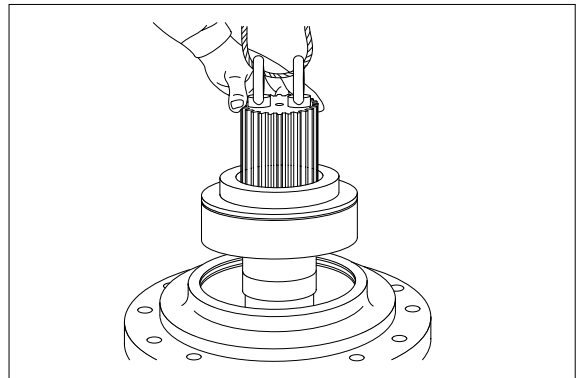

- ③ Assemble snap ring(3).
※ When assembling, loosen cutting place of snap ring about 30mm from connections of gear casing for easy disassembly.

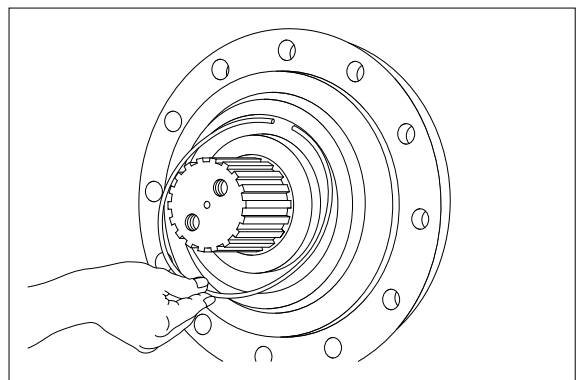

(4) Assembly of roller bearing

Put gear casing under pinion shaft. Heat inner race of roller bearing(9) up to 50°C plus surrounding temperature and assemble to center of pinion shaft. Assemble roller bearing by putting between gear casing and pinion shaft.

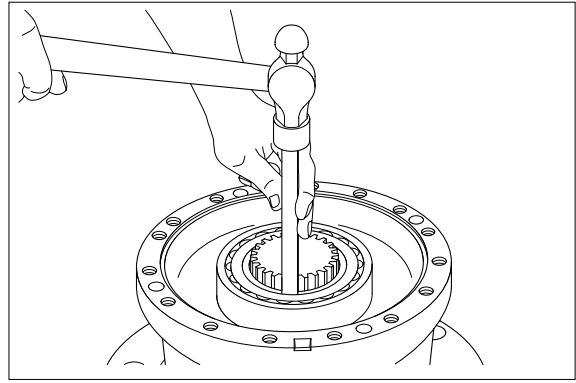

(5) Assembly of ring gear

- ① Remove oil from mating faces between gear casing(6) and ring gear(12), and from pin(10). Assemble collar to gear casing and apply fluid packing(three bond of grey color).

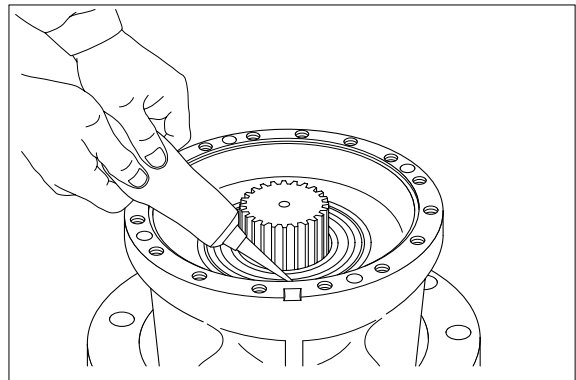

- ② Assemble ring gear(12).

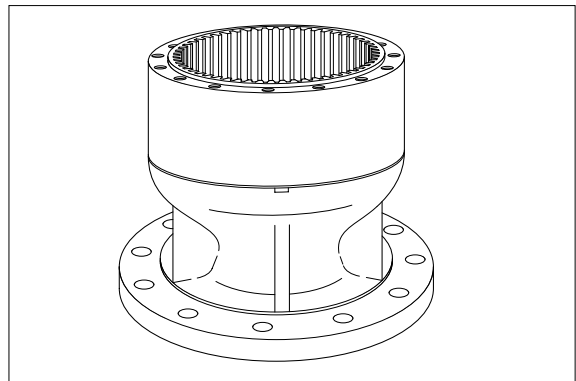

(6) Assembly of holder assembly

- ① Assemble bushing(21) to planetary gear 5(22).
Insert shaft 2(20) after putting plate(23) and bushing(21) to holder(25).
- ※ Lubricate gear oil to inside of gear and outside of shaft.

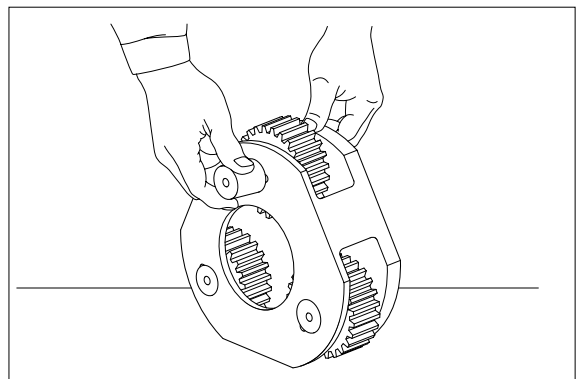

- ② Insert spring pin(24) by hammering.
- ※ Insert as the clearance between spring pins toward gear(22).

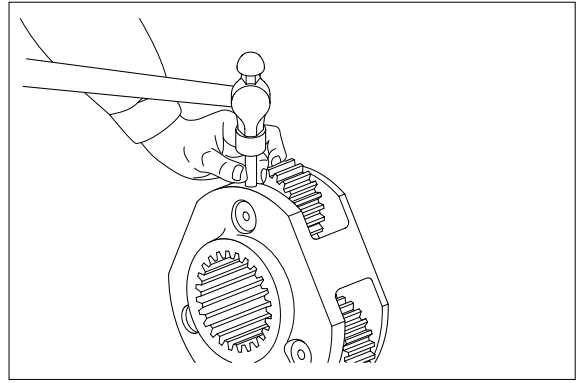

(7) Assembly of 2nd holder assembly and planetary gear 4

- ① Insert holder assembly being engaged with internal teeth of ring gear(12). Rotate holder assembly lightly so that splines of pinion shaft(1) are engaged.

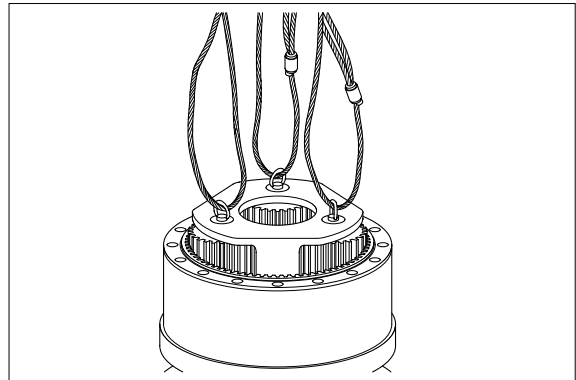

- ② Insert planetary gear 4(11) thrust plate to gear 5(22).

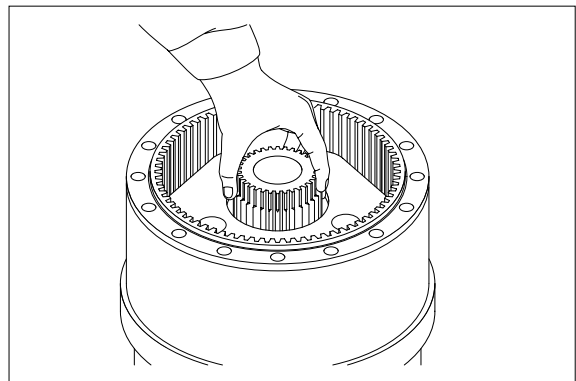

(8) Assembly of sun gear and 1st holder assembly

- ① Insert holder assembly being engaged with internal teeth of ring gear(12). Rotate holder assembly lightly so that planetary gear 4(11) is engaged with teeth of holder 1(13).

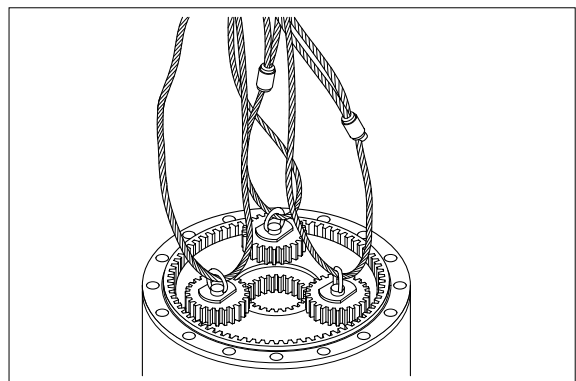

- ② Insert sun gear(14) to planetary gear 2(15).

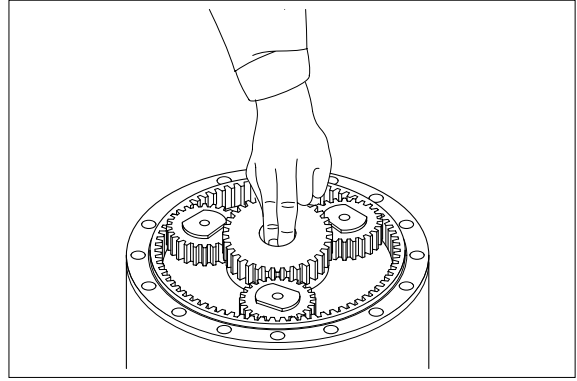

- (9) Check rotation of sun gear by turning 1st holder assembly with hands.

This completes assembly.

