

## GROUP 5 MECHATRONICS SYSTEM BY HYPER DAT

### 1. ALL ACTUATORS SPEED ARE SLOW

- Before using the HYPER DAT make sure you understand the user's guide of HYPER DAT.
  - Before mounting or dismounting the HYPER DAT, always turn the starting switch OFF.
  - Before starting switch turn ON or OFF, check all related connectors are properly inserted.
- ※ Confirm the engine speed is normal. If not, fix the engine speed to each mode specification.

Spec : H mode	2200 ±50rpm	S mode	2200 ±50rpm
L mode	2000 ±50rpm	F mode	1600 ±50rpm

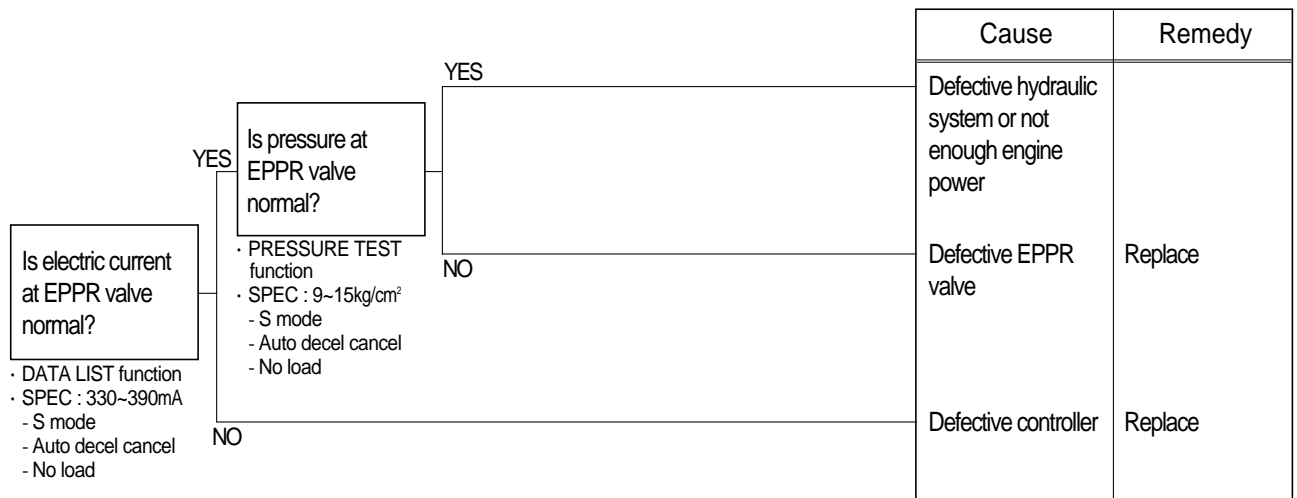

### Wiring diagram

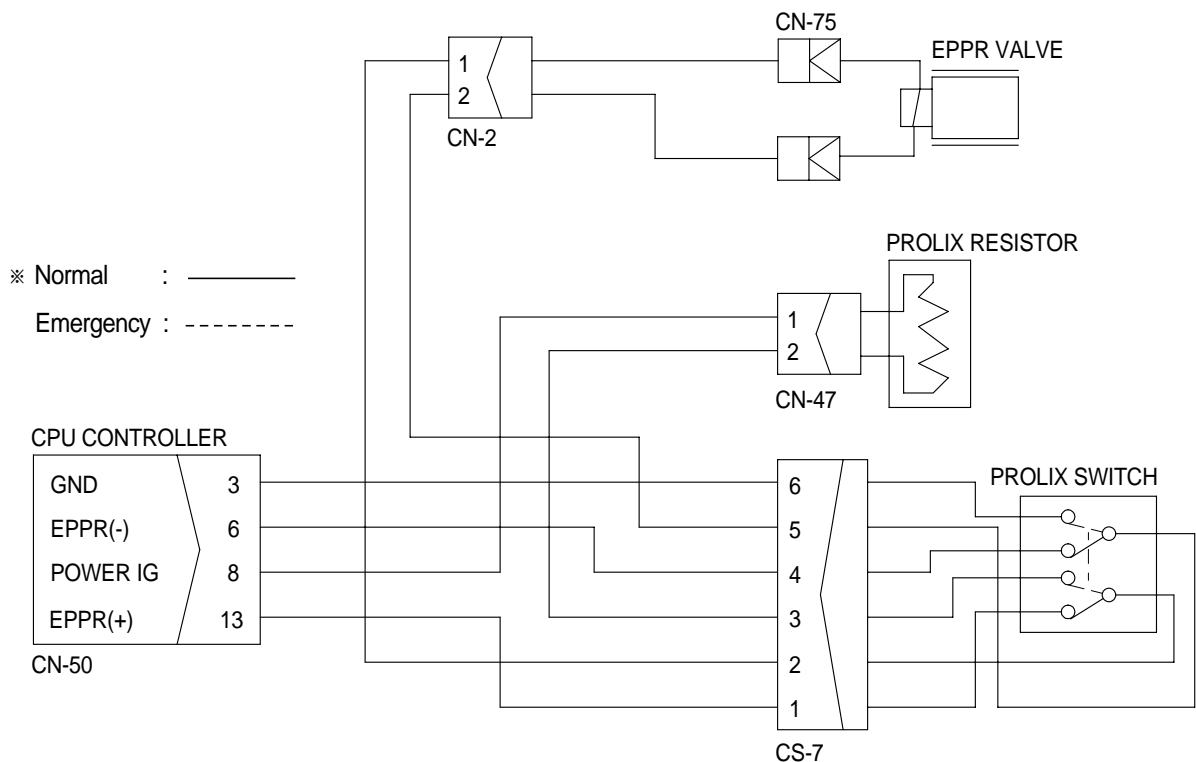

## 2. CLUSTER LAMPS ARE OFF IMMEDIATELY AFTER KEY SWITCH OFF

- Before using the HYPER DAT make sure you understand the user's guide of HYPER DAT.
- Before mounting or dismounting the HYPER DAT, always turn the starting switch OFF.
- Before starting switch turn ON or OFF, check all related connectors are properly inserted.

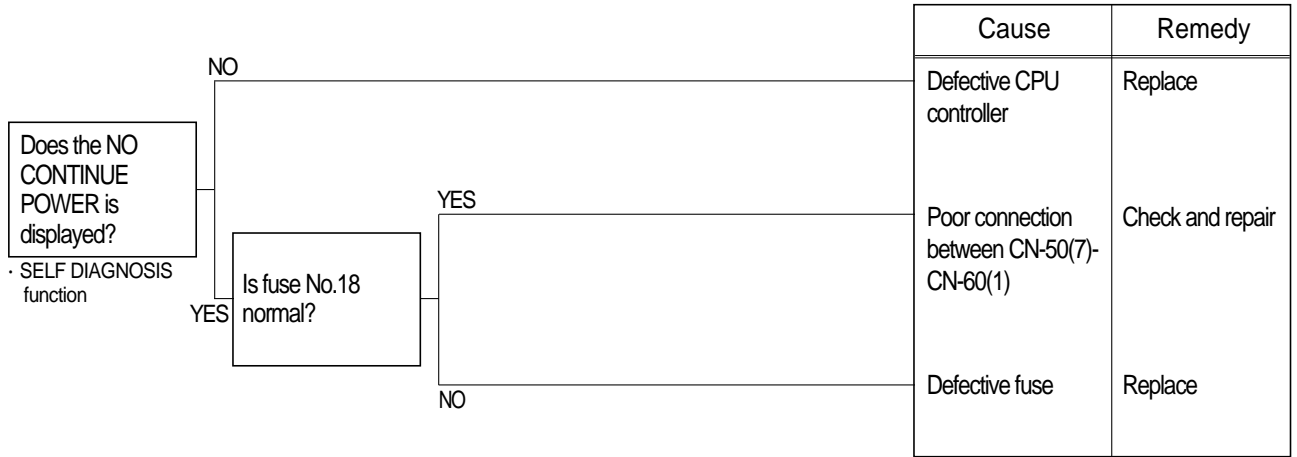

### Wiring diagram

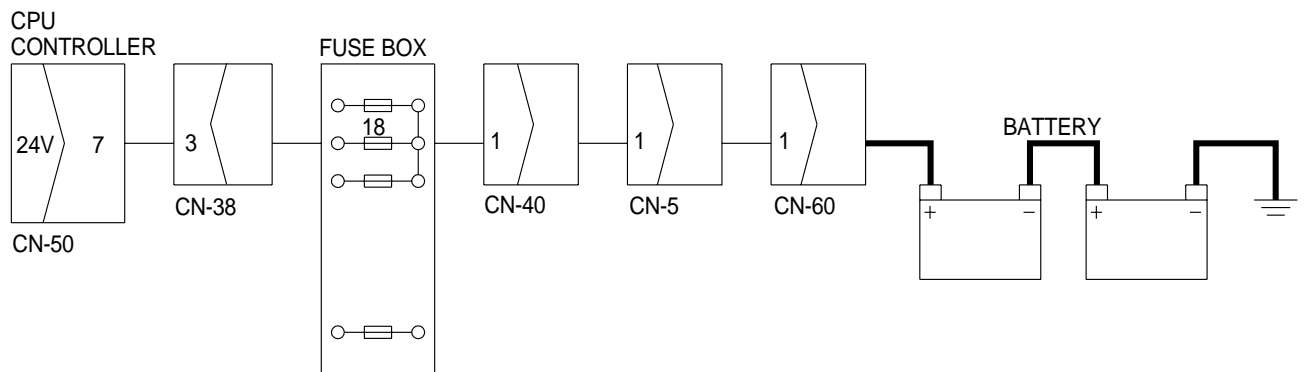

### 3. CLUSTER LAMPS ARE STILL ON AFTER STARTING KEY OFF

- Before using the HYPER DAT make sure you understand the user's guide of HYPER DAT.
- Before mounting or dismounting the HYPER DAT, always turn the starting switch OFF.
- Before starting switch turn ON or OFF, check all related connectors are properly inserted.

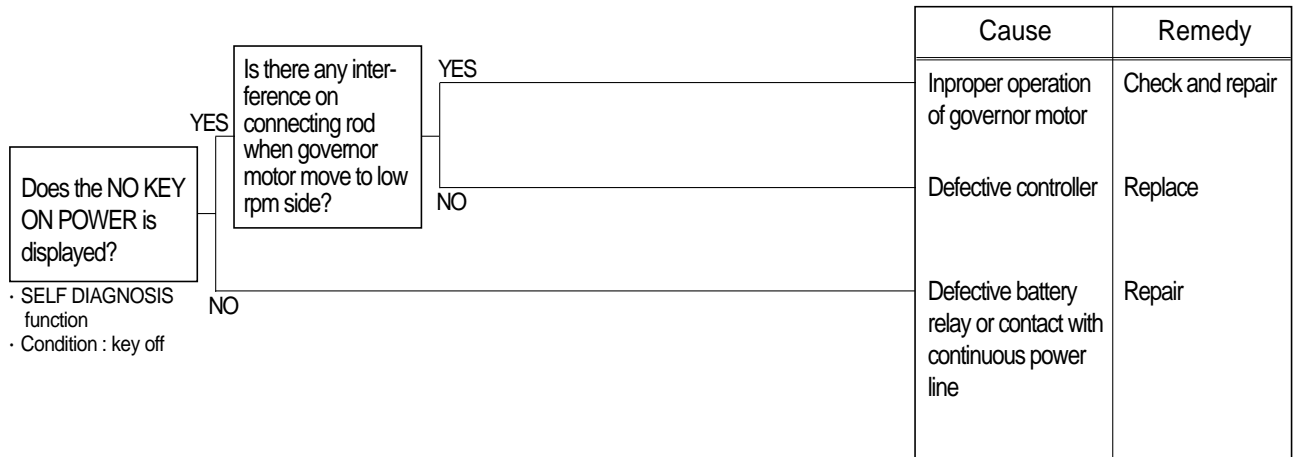

#### Wiring diagram

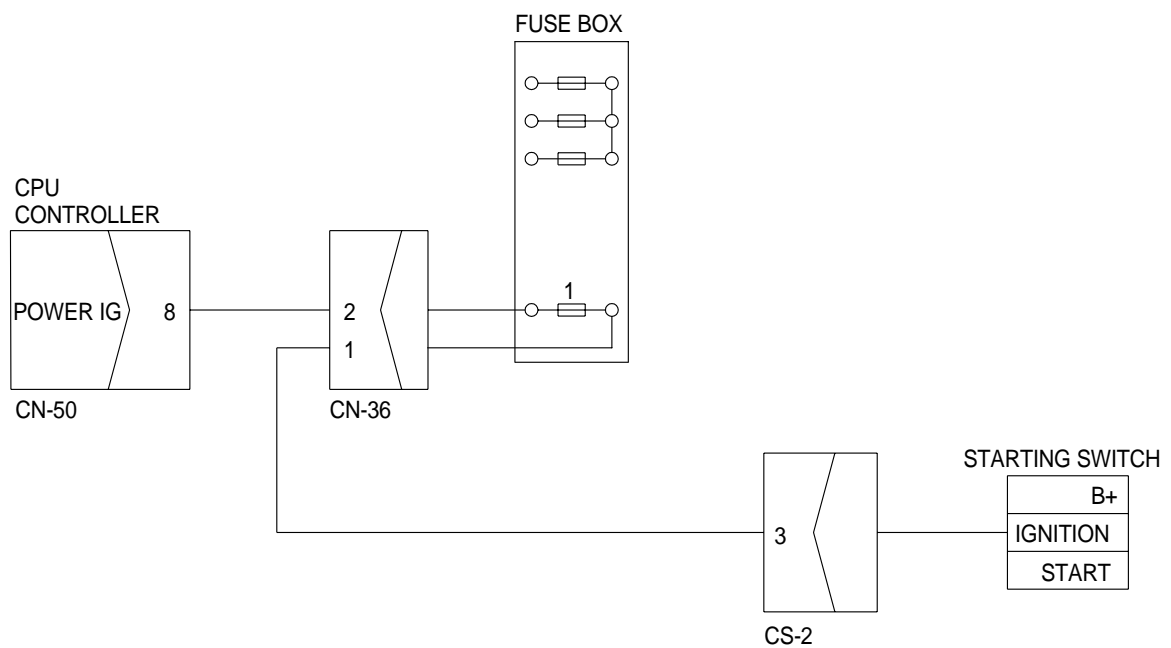

#### 4. CLUSTER LAMPS ARE NOT CHANGING OR FUNCTION IS ABNORMAL WHEN THE RELATED SWITCH ARE PUSHED

- Before using the HYPER DAT make sure you understand the user's guide of HYPER DAT.
- Before mounting or dismounting the HYPER DAT, always turn the starting switch OFF.
- Before starting switch turn ON or OFF, check all related connectors are properly inserted.

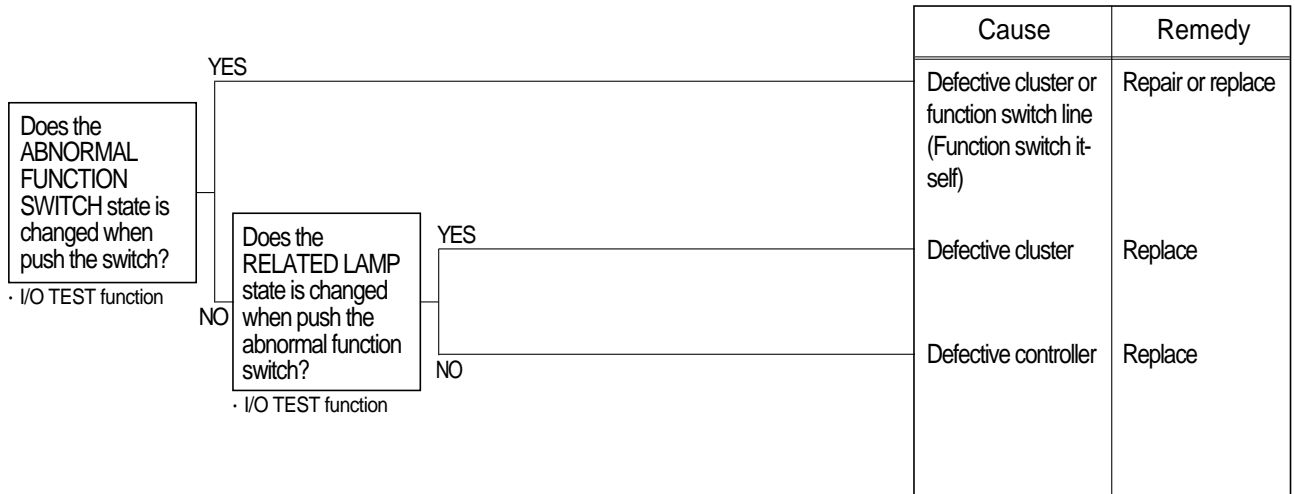

#### Wiring diagram

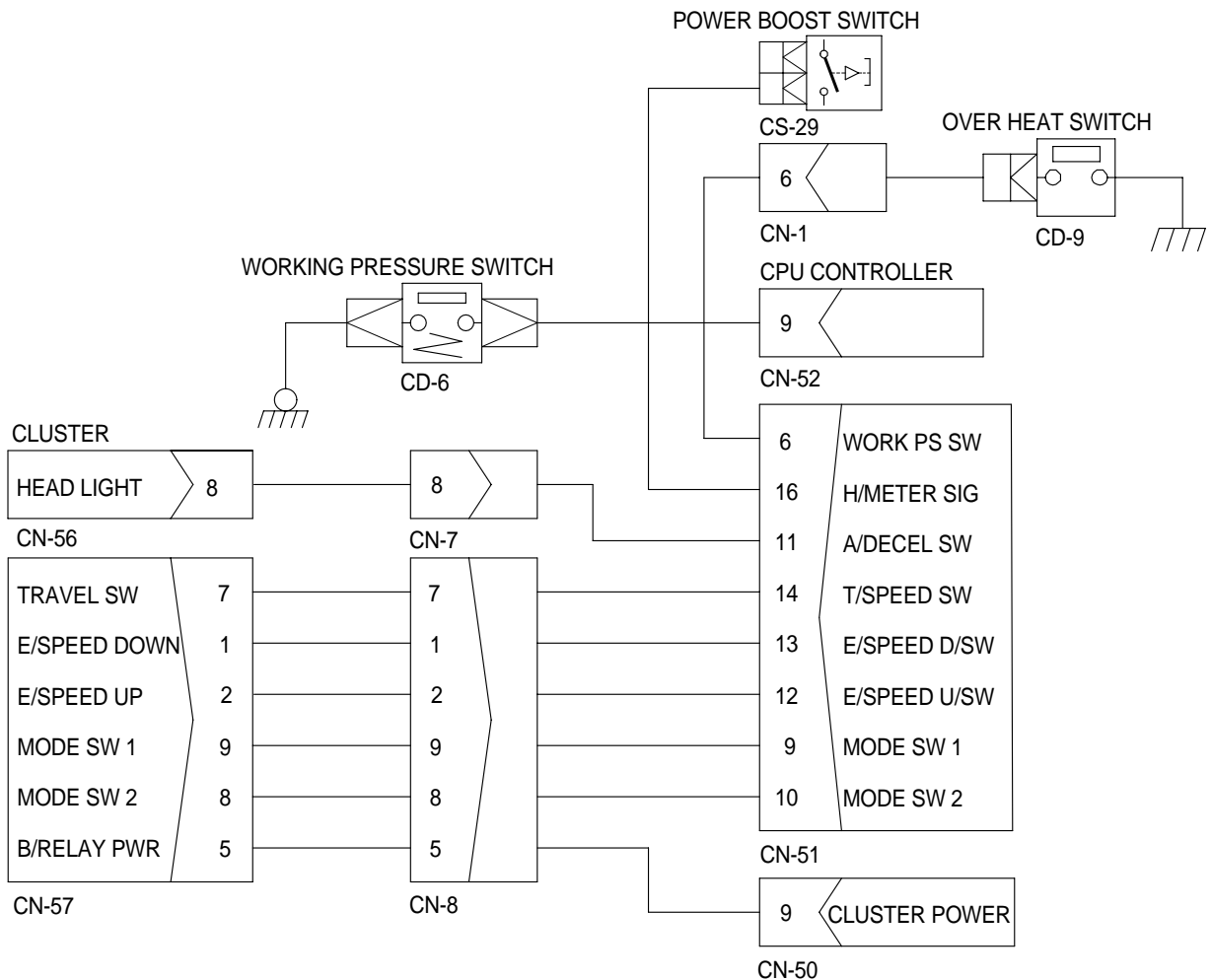

## 5. AUTO DECEL SYSTEM DOES NOT WORK

- Before using the HYPER DAT make sure you understand the user's guide of HYPER DAT.
- Before mounting or dismounting the HYPER DAT, always turn the starting switch OFF.
- Before starting switch turn ON or OFF, check all related connectors are properly inserted.

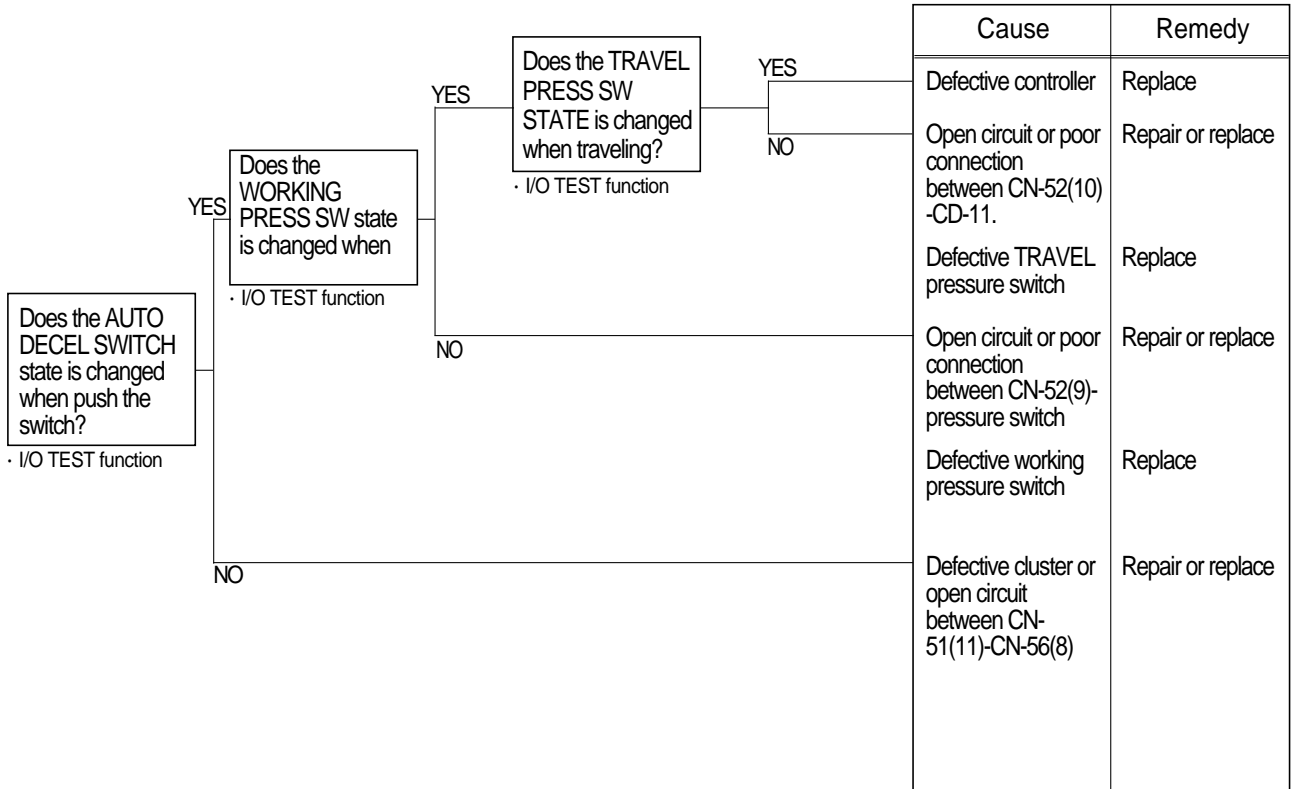

### Wiring diagram

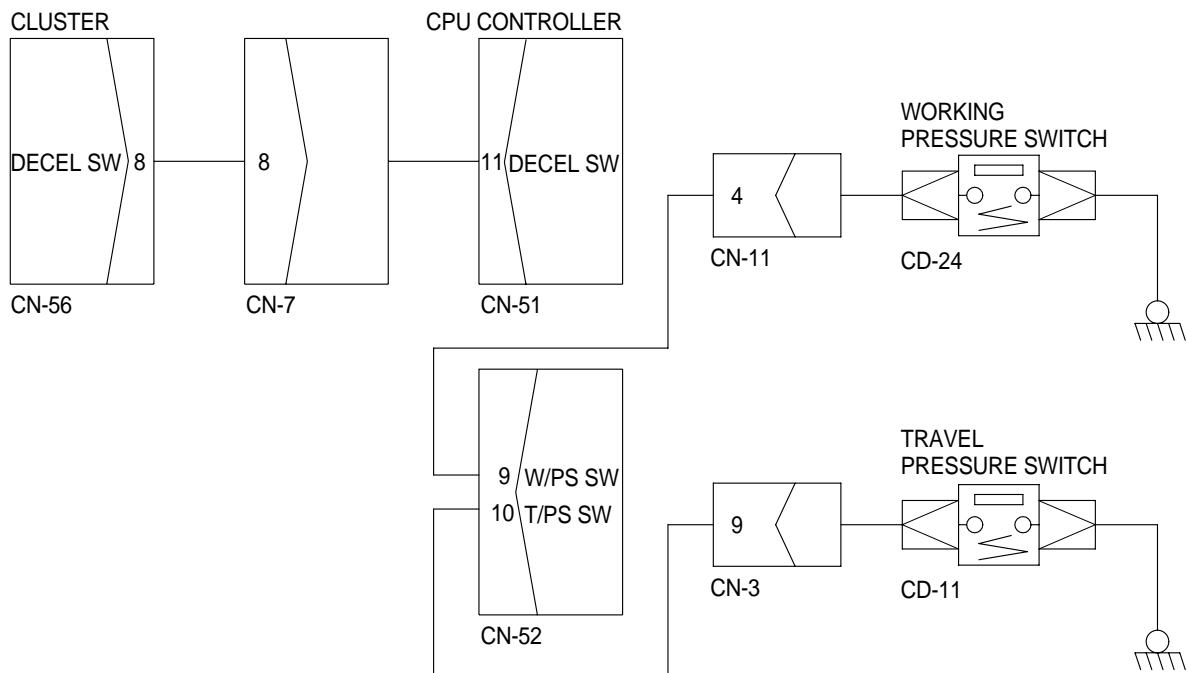

## 6. ENGINE SPEED IS NOT CHANGING WHEN CHANGE THE MODE

- Before using the HYPER DAT make sure you understand the user's guide of HYPER DAT.
- Before mounting or dismounting the HYPER DAT, always turn the starting switch OFF.
- Before starting switch turn ON or OFF, check all related connectors are properly inserted.

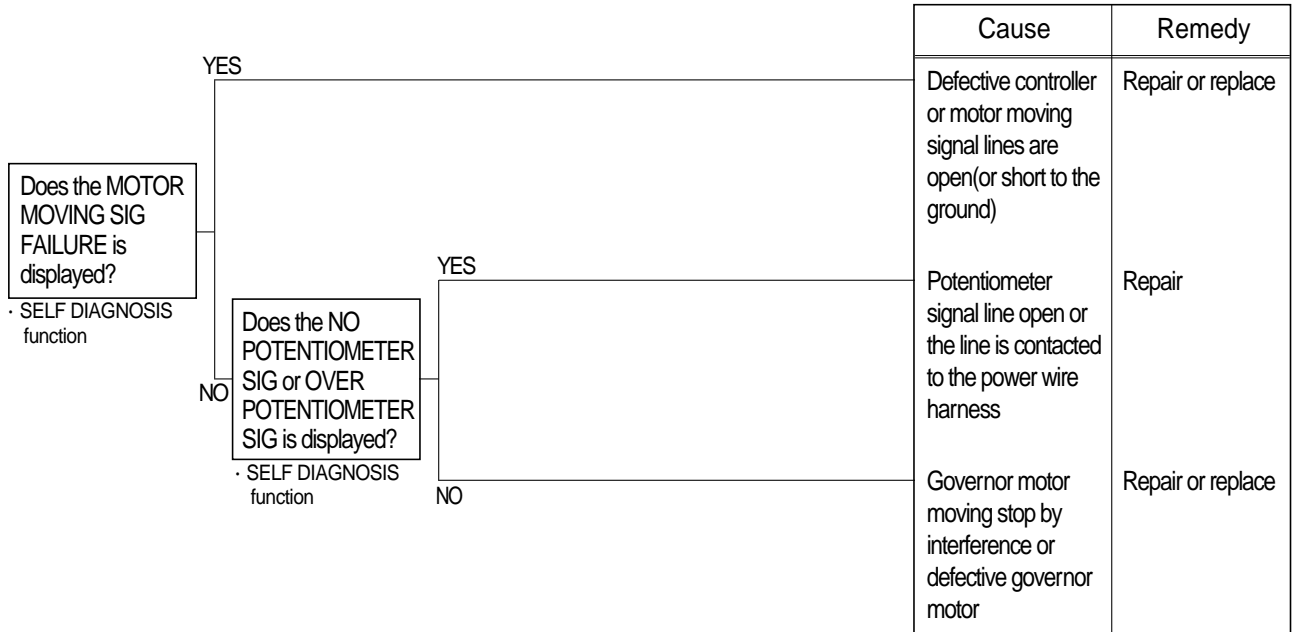

### Wiring diagram

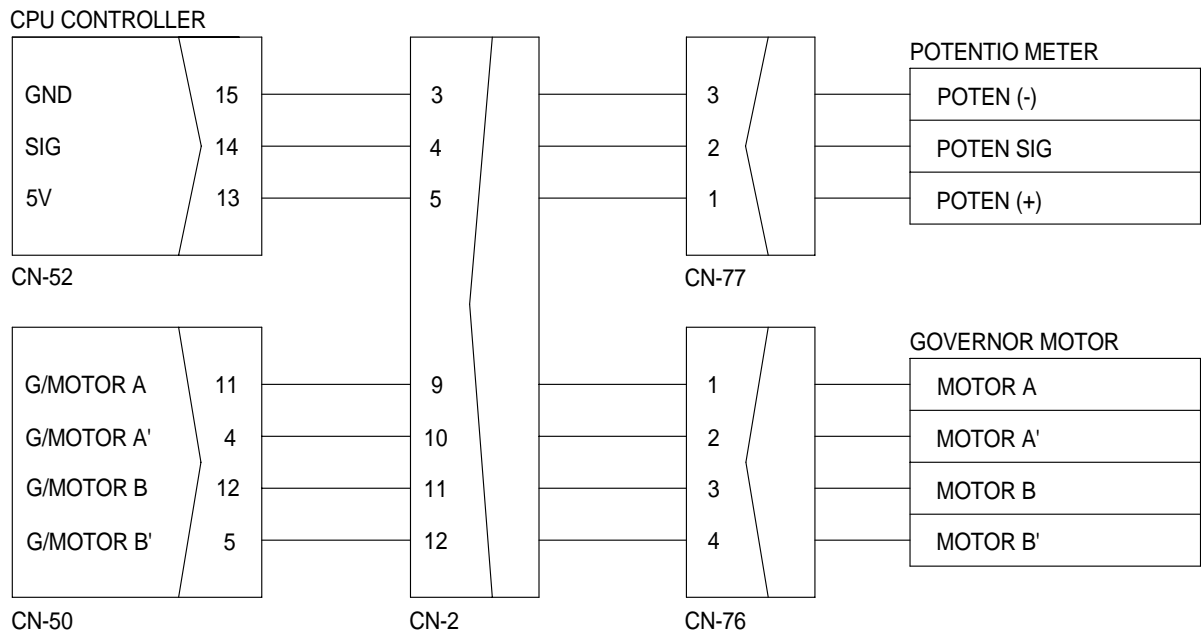

## 7. MALFUNCTION OF POWER BOOST

- Before using the HYPER DAT make sure you understand the user's guide of HYPER DAT.
- Before mounting or dismounting the HYPER DAT, always turn the starting switch OFF.
- Before starting switch turn ON or OFF, check all related connectors are properly inserted.

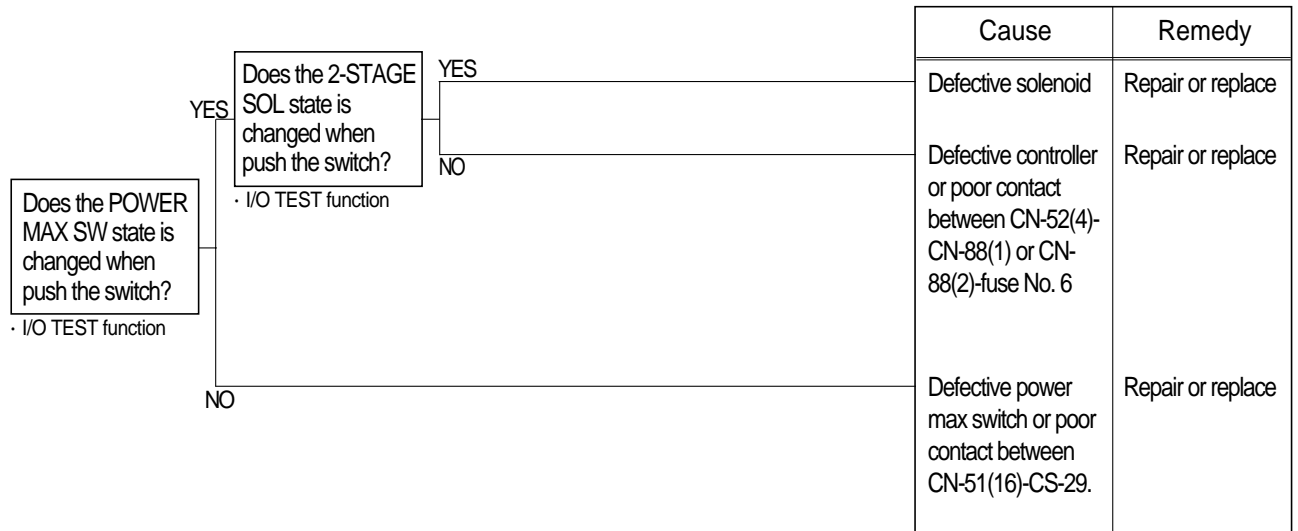

### Wiring diagram

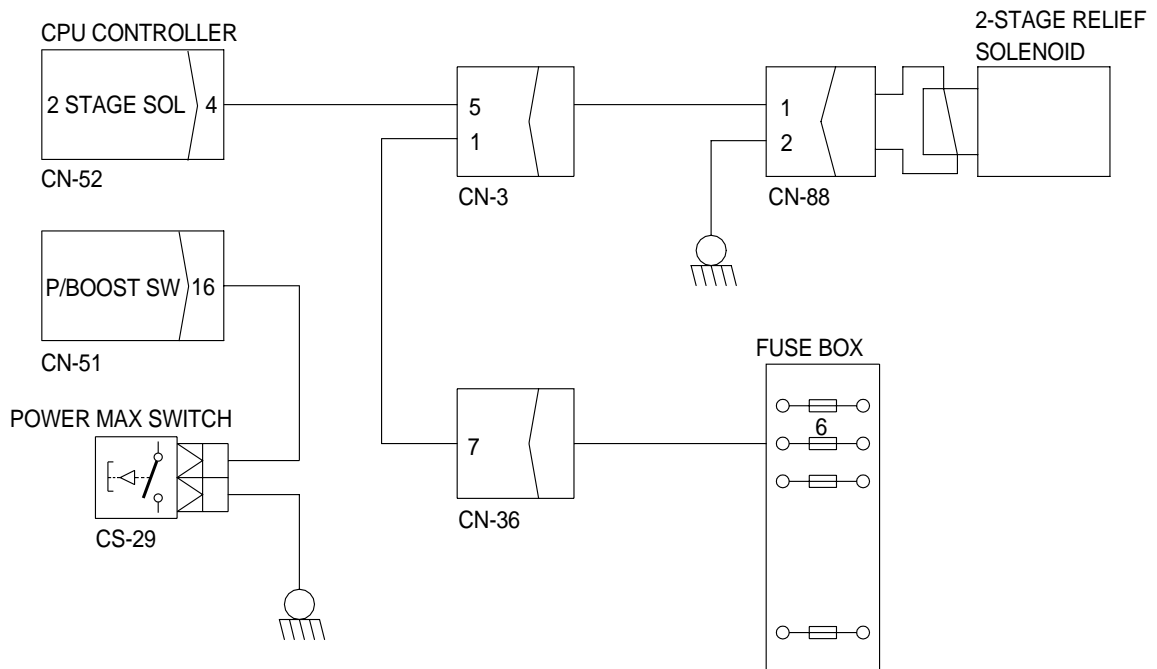

## 8. EXCESSIVE DROP IN ENGINE SPEED OR ENGINE STALLS, WHEN A LOAD IS APPLIED

- Before using the HYPER DAT make sure you understand the user's guide of HYPER DAT.
- Before mounting or dismounting the HYPER DAT, always turn the starting switch OFF.
- Before starting switch turn ON or OFF, check all related connectors are properly inserted.

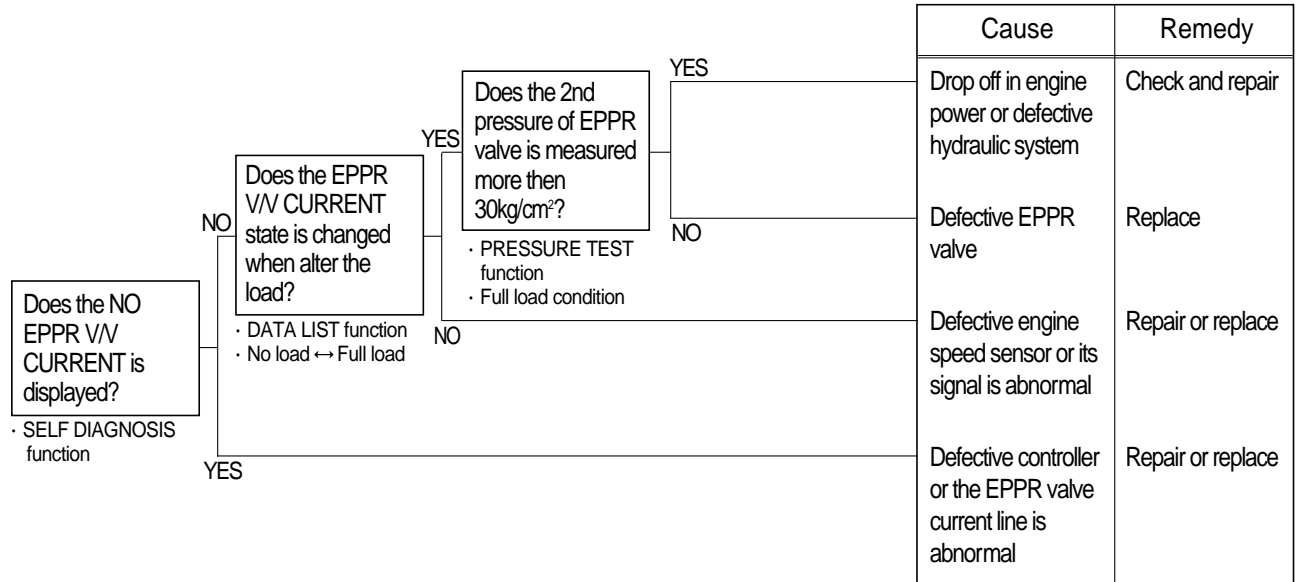

### Wiring diagram

