

GROUP 11 ENGINE OVERHEAT PREVENTION FUNCTION

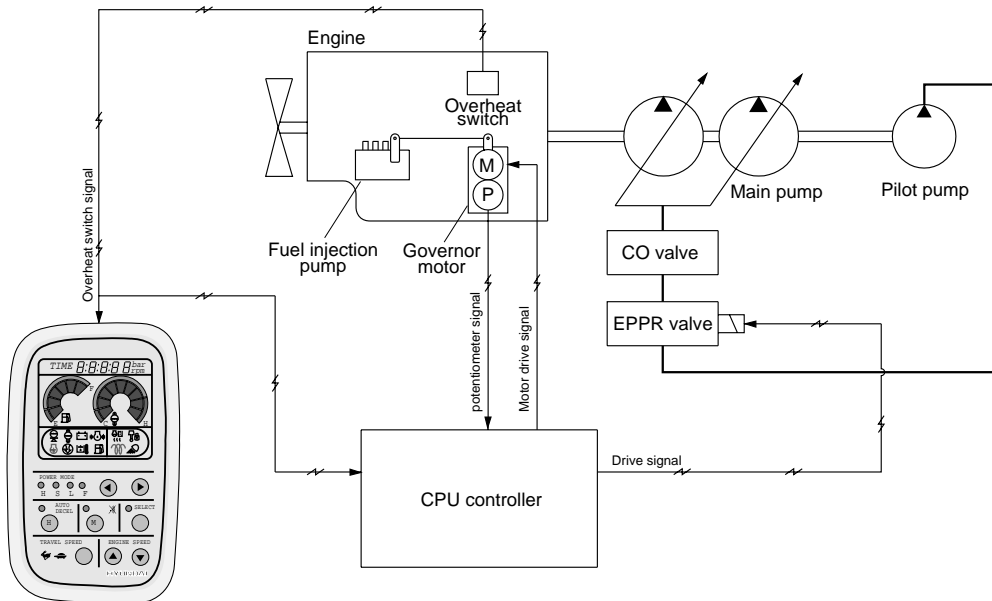

1. When the engine coolant boils upto 110°C, the overheat switch is ON, and if the temperature drops to 100°C, the switch is OFF.
 2. When the overheat switch is ON, engine overheat warning buzzer and lamp work and mode set is changed to **F** mode automatically on the cluster.
 3. If the coolant temperature drops to 100°C or mode set is changed among the function, the cluster sends the overheat prevention cancel signal to the CPU controller. Thereby the CPU controller returns the mode to the mode set before.
- ※ Even if the overheat prevention function is canceled by mode change, the overheat warning lamp turns OFF only when the overheat switch is OFF, that is, the coolant temperature is less than 100°C

4. Logic table(1)

Description	Condition	Function
Actuated	- Coolant temperature : Above 110°C	- Mode : H, S, L → F - Overheat warning lamp & buzzer : ON
Canceled	- Coolant temperature : Less than 100°C - Changed mode by operator ※ If any of the above conditions is applicable, engine overheat prevention function is canceled	- Return to the mode set before - Hold on the changed mode
Overheat warning lamp	- Coolant temperature : Less than 100°C	- Lamp OFF

5. Logic table(2)

	Overheat switch	
	ON	OFF
Condition	Coolant temp : Above 110°C	Coolant temp : Less than 100°C
Signal	Low(GND)	High(5V)
Lamp & buzzer (cluster)	ON	OFF
Mode set (CPU controller)	F	Default