

GROUP 2 ELECTRICAL CIRCUIT

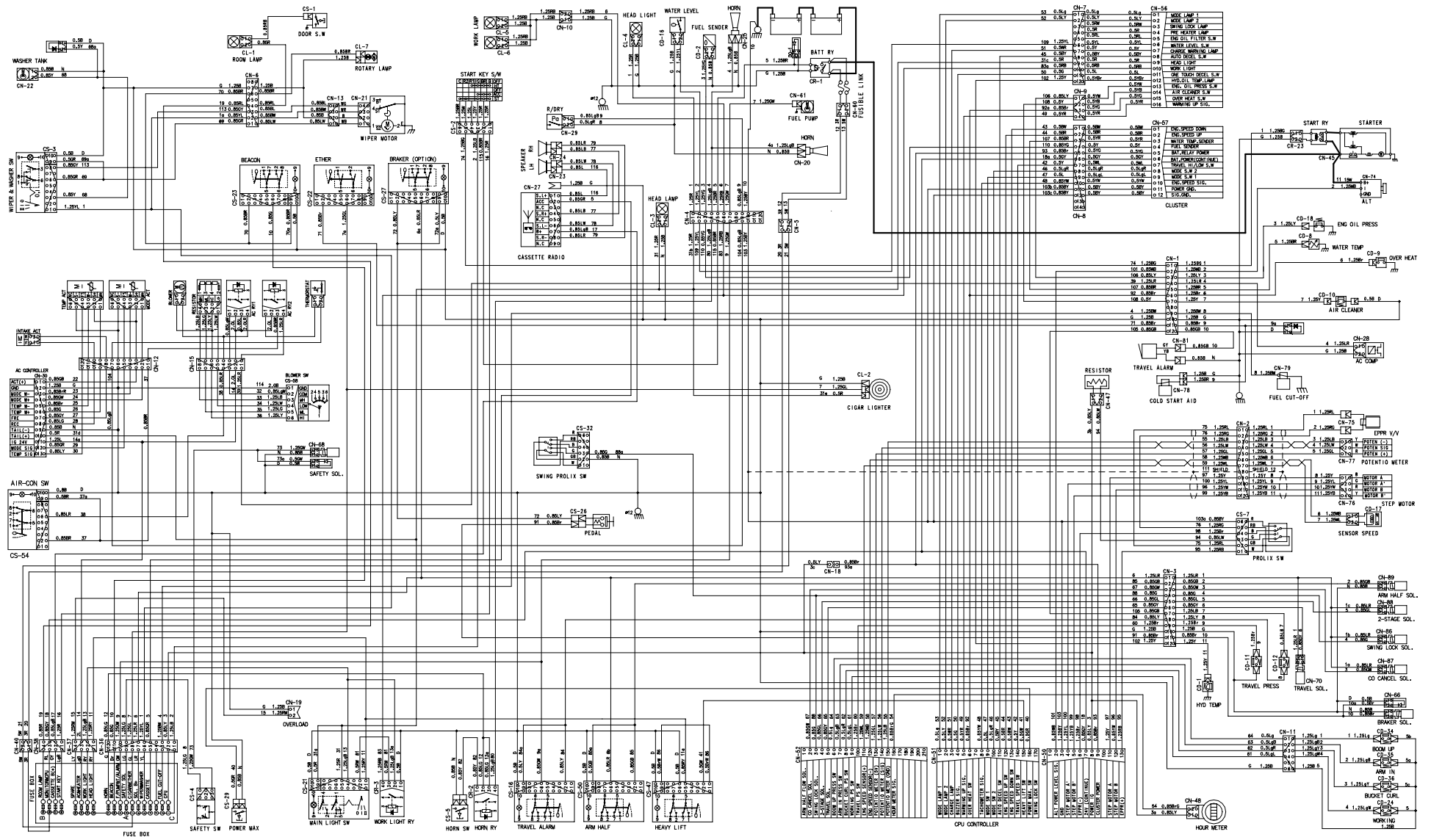

## 1. POWER CIRCUIT

The negative terminal of battery is grounded to the machine chassis.

When the start switch is in the OFF position, the current flows from the positive battery terminal as shown here.

### 1) OPERATING FLOW

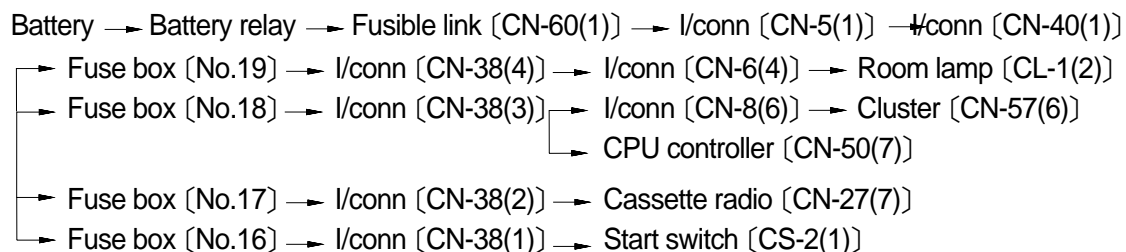

### 2) CHECK POINT

Engine	Start switch	Check point	Voltage
OFF	OFF	① - GND (Battery 1 EA) ② - GND (Battery 2 EA) ③ - GND (Battery 2 EA) ④ - GND (Fusible link )	10 ~ 12.5V 20 ~ 25V 20 ~ 25V 20 ~ 25V

※ GND : Ground

# POWER CIRCUIT

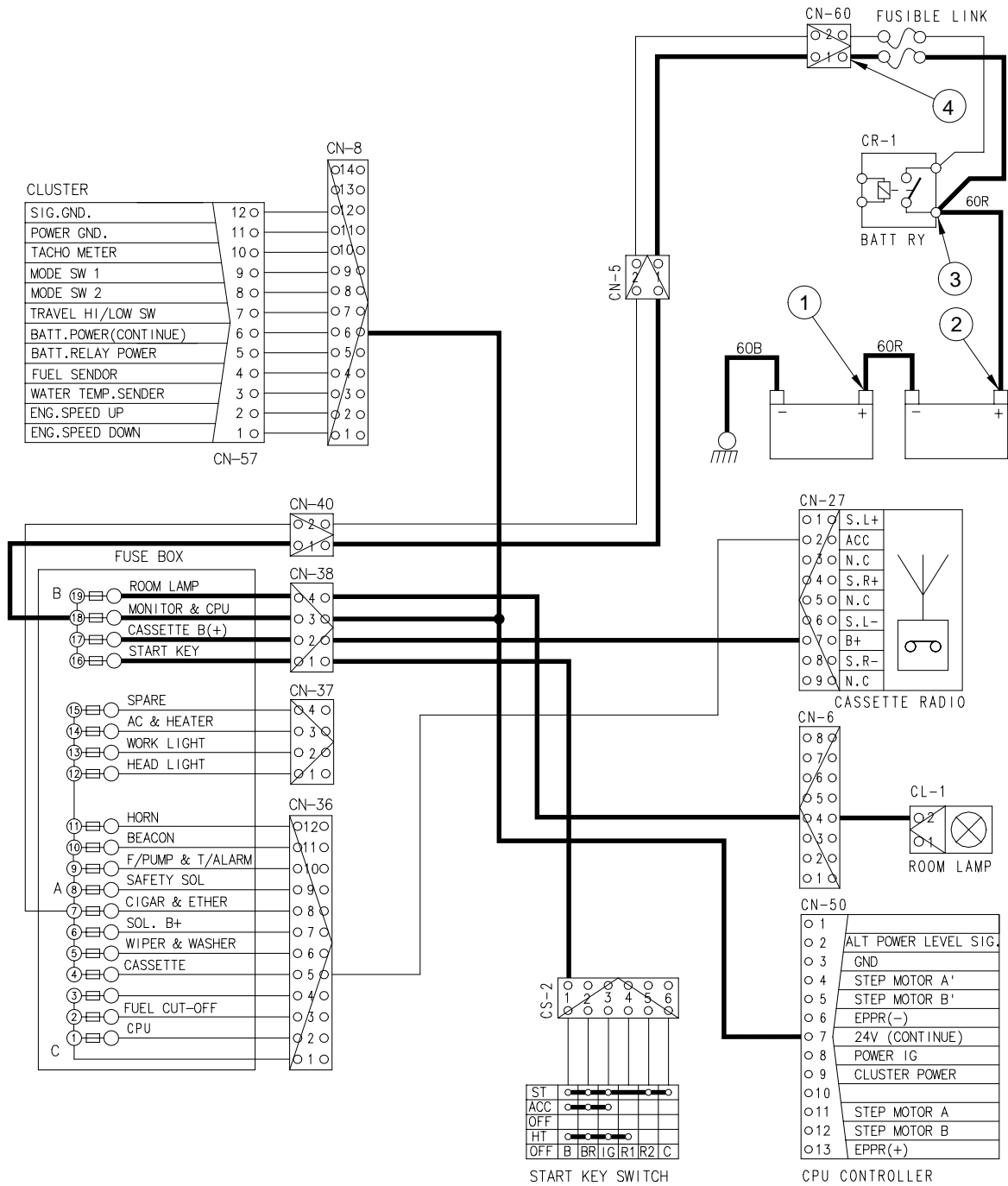

## 2. STARTING CIRCUIT

### 1) OPERATING FLOW

Battery(+) terminal → Battery relay(M8, B<sup>+</sup> terminal) → Fusible link [CN-60(1)]  
 → I/conn [CN-5(1)] → I/conn [CN-40(1)] → Fuse box [NO.16] → Start switch [CS-2(1)]

#### (1) Start switch : ON

→ Start switch ON [CS-2(2)] → I/conn [CN-4(5)] → Battery relay [M4 terminal]  
 → Battery relay operating(All power is supplied with the electric component)  
 → Start switch ON [CS-2(3)] → I/conn [CN-36(1)]  
 → Fuse box(No.1)  
 → Fuse box(No.2) → I/conn [CN-36(3)] → I/conn [CN-1(9)]  
 → Fuel cut-off [CN-79]  
 → Fuse box(No.3)

#### (2) Start switch : START

Start switch START [CS-2(5)] → I/conn [CN-1(1)] → Start relay [CR-23(1)]

### CHECK POINT

Engine	Start switch	Check point	Voltage
Operating	Start	① - GND (Battery) ② - GND (Start key) ③ - GND (Battery relay M4) ④ - GND (Start B) ⑤ - GND (Start S) ⑥ - GND (Start relay) ⑦ - GND (Battery relay M8)	20 ~ 25V

※ GND : Ground

# STARTING CIRCUIT

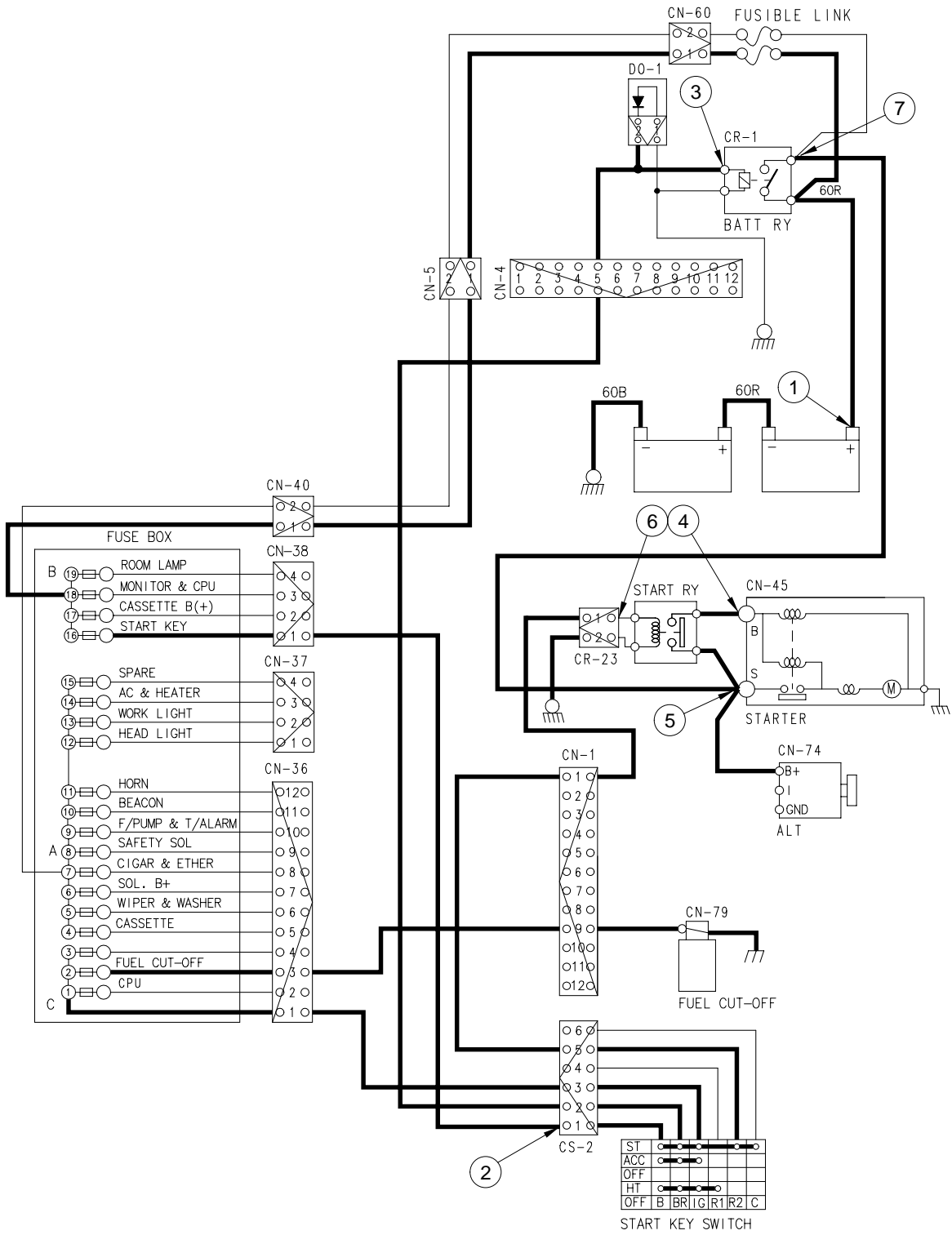

### 3. CHARGING CIRCUIT

When the starter is activated and the engine is started, the operator releases the key switch to the ON position.

Charging current generated by operating alternator flows into the battery through the battery relay(CR-1).

The current also flows from alternator to each electrical component and controller through the fuse box.

#### 1) OPERATING FLOW

##### (1) Warning flow

Alternator "I" terminal → I/conn [CN-1(2)] → CPU Alternator power level [CN-50(2)],  
Charging lamp [CN-51(3)] → I/conn [CN-7(7)] → Cluster charging warning lamp [CN-56(7)]

##### (2) Charging flow

Alternator B<sup>+</sup> terminal → Battery relay (M8) → Battery(+) terminal  
→ Fusible link [CN-60(2)] →  
I/conn [CN-5(2)] → I/conn [CN-40(2)] → Fuse box

#### 2) CHECK POINT

Engine	Start switch	Check point	Voltage
ON	ON	① - GND (Battery voltage) ② - GND (Battery relay) ③ - GND (Alternator B <sup>+</sup> terminal) ④ - GND (Alternator I terminal) ⑤ - GND (CPU) ⑥ - GND (CPU) ⑦ - GND (Cluster)	20 ~ 27V

※ GND : Ground

# CHARGING CIRCUIT

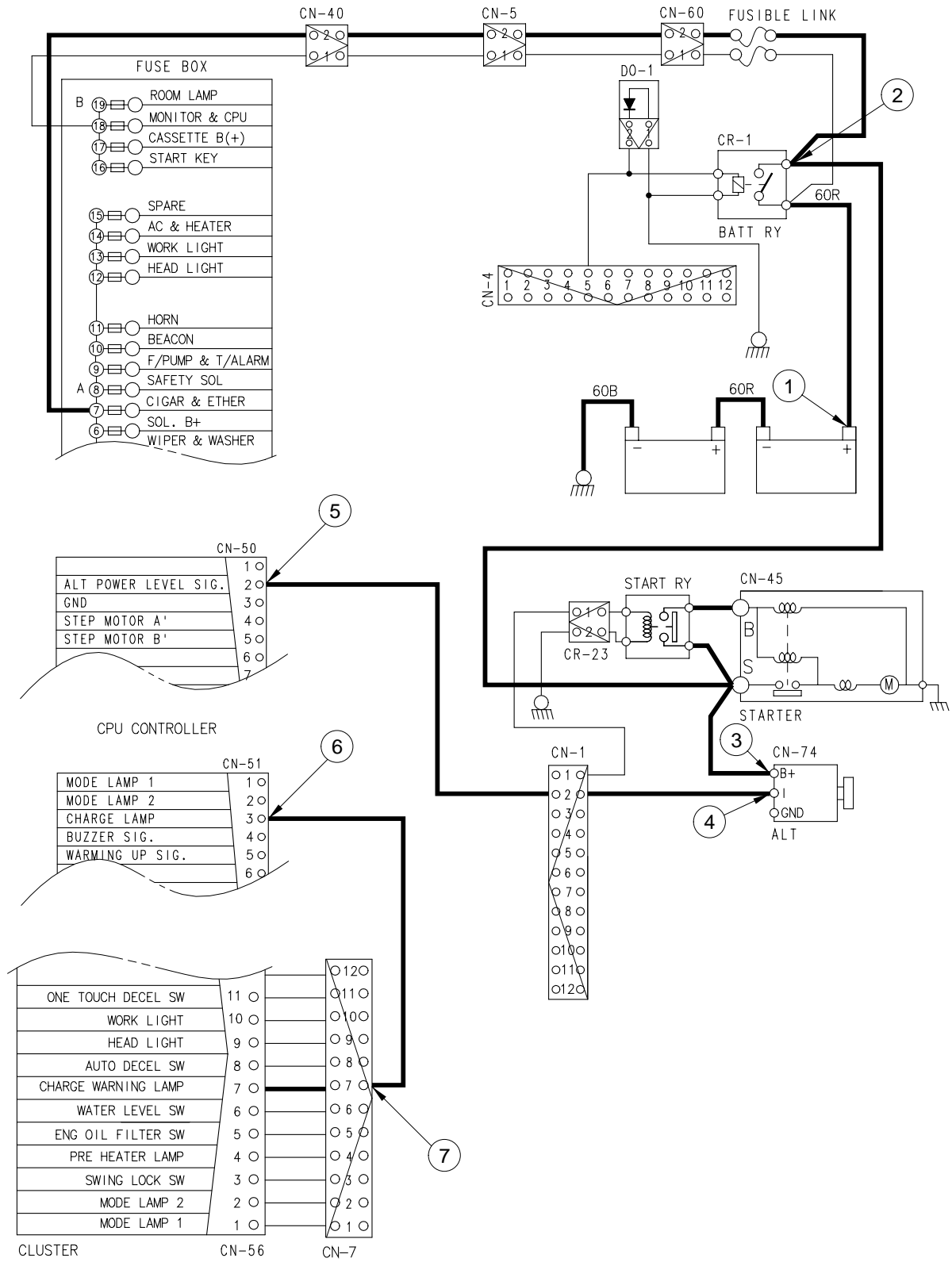

#### 4. HEAD AND WORK LIGHT CIRCUIT

##### 1) OPERATING FLOW

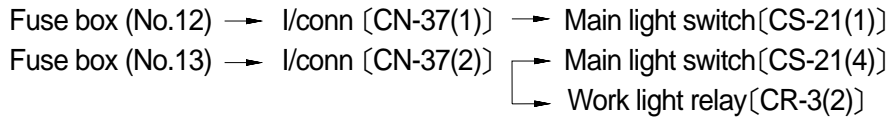

##### (1) Head light switch ON : 1st step

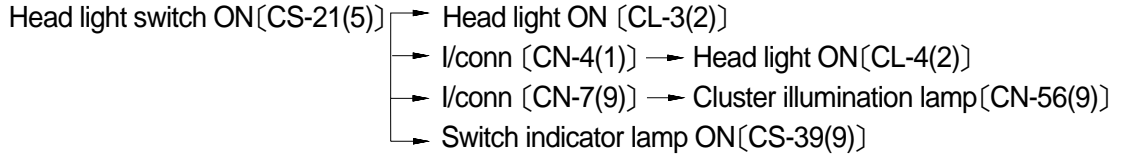

##### (2) Work light switch ON : 2nd step

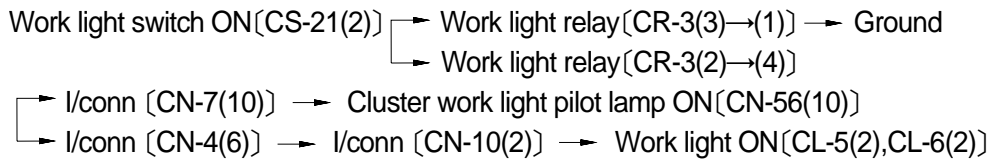

##### 2) CHECK POINT

Engine	Key switch	Check point	Voltage
STOP	ON	① - GND(Fuse box) ③ - GND(Switch power input) ⑤ - GND(Switch power output) ⑩ - GND(Work lamp)	20 ~ 25V
STOP	ON	② - GND(Fuse box) ④ - GND(Switch power input) ⑥ - GND(Switch power output) ⑦ - GND(Relay output) ⑧ - GND(Relay coil) ⑨ - GND(Relay input) ⑪ - GND(Head lamp)	20 ~ 25V

※ GND : Ground



# HEAD AND WORK LAMP CIRCUIT

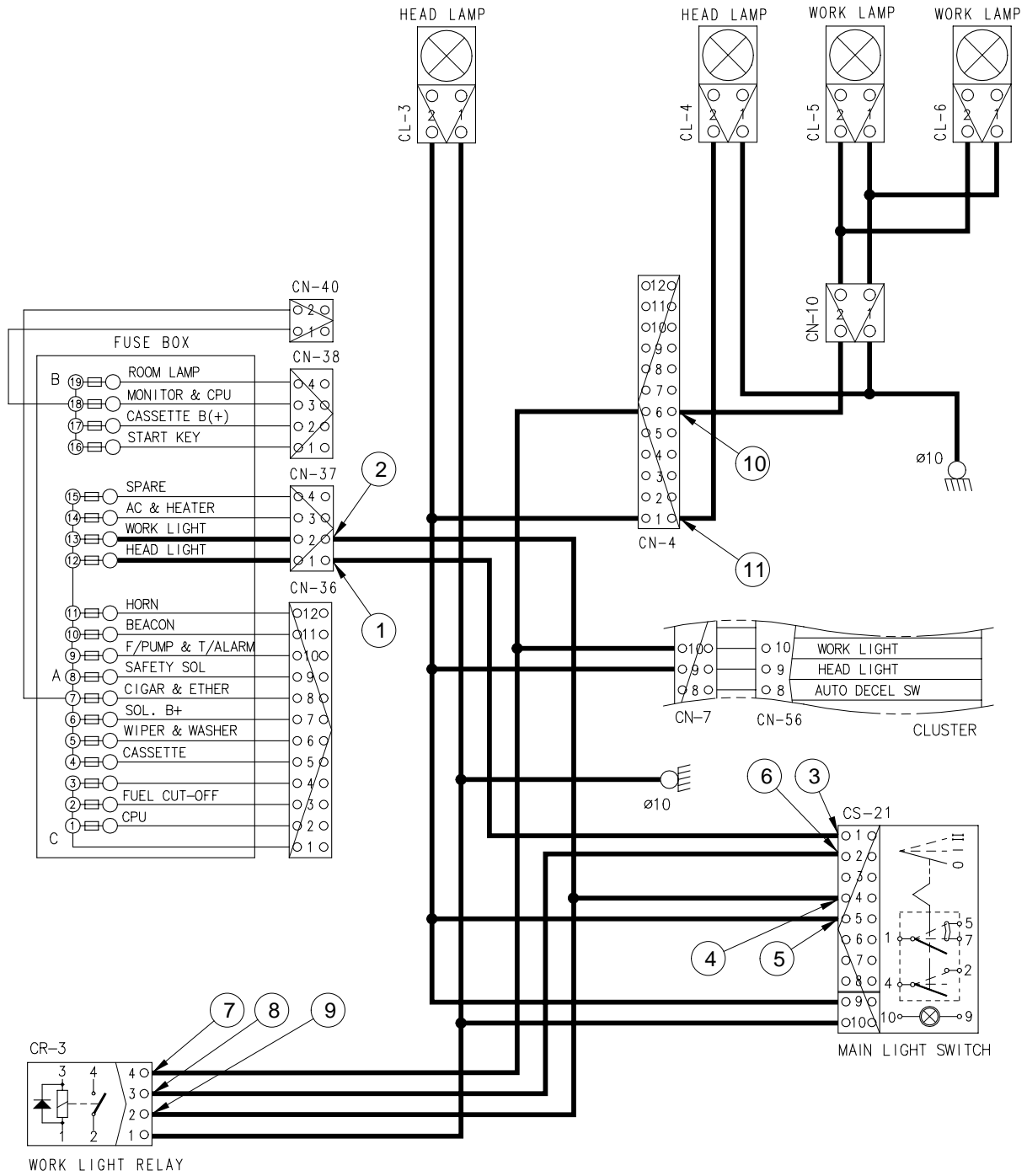

## 5. BEACON LAMP CIRCUIT

### 1) OPERATING FLOW

Fuse box (No.10) → I/conn [CN-36(11)] → Beacon lamp switch [CS-23(6)]

#### ※ When lamp switch ON

Beacon lamp switch ON [CS-23(2)] → I/conn [CN-6(6)] → Beacon lamp ON [CL-7]  
Switch indicator lamp ON [CS-23(9)]

### 2) CHECK POINT

Engine	Key switch	Check point	Voltage
STOP	ON	① - GND (Fuse box) ② - GND (Switch power input) ③ - GND (Switch power output) ④ - GND (Beacon lamp)	20 ~ 25V

※ GND : Ground

# BEACON LAMP CIRCUIT

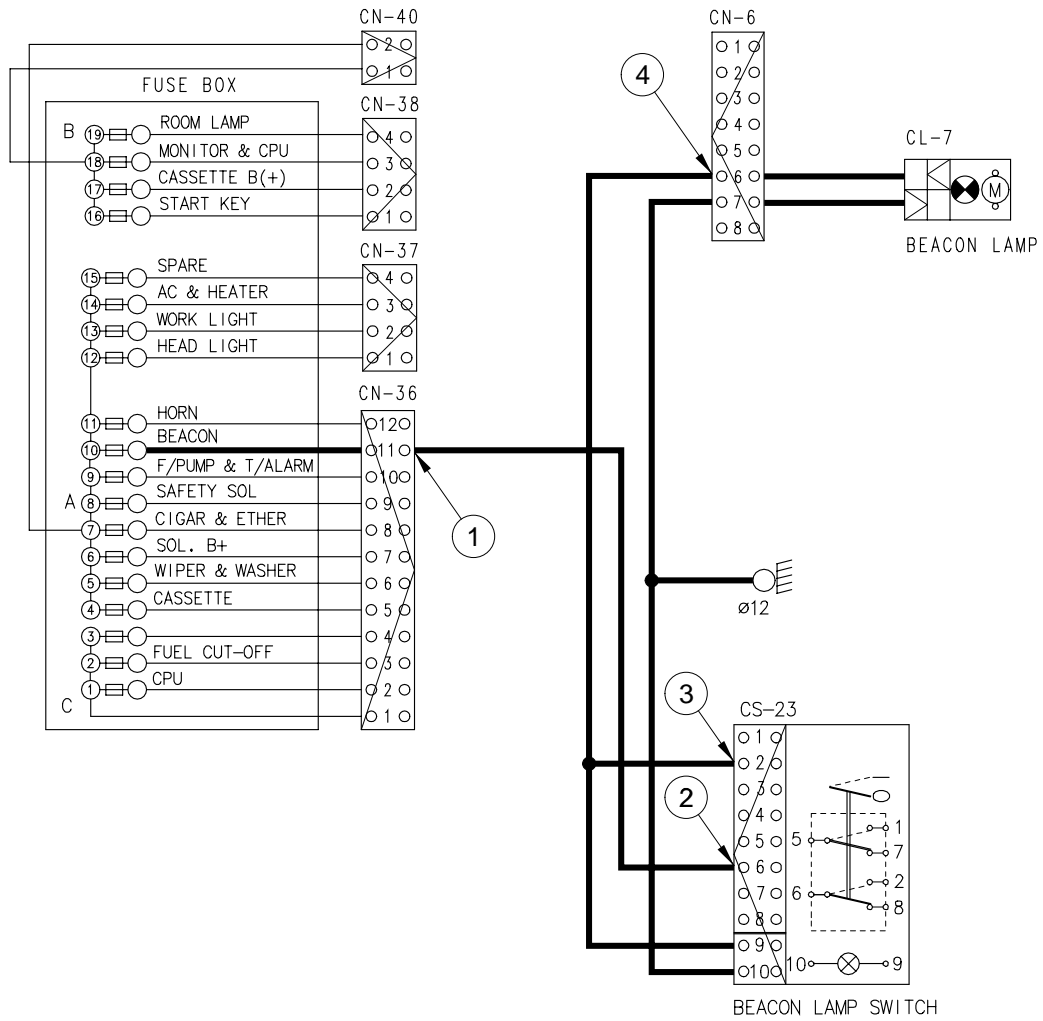

## 6. WIPER AND WASHER CIRCUIT

### 1) OPERATING FLOW

#### (1) Wiper motor switch ON : 1st step

Fuse box (No.5) → I/conn [CN-36(6)] → Wiper and washer switch [CS-3(1)→(6)]  
 ↳ I/conn [CN-6(2)] → I/conn [CN-13(1)] → Wiper operation [CN-21(1)]  
 ↳ Switch indicator lamp ON [CS-3(9)]

#### (2) Washer switch ON : 2nd step

Fuse box(No.5) → I/conn [CN-36(6)] → Wiper and washer switch [CS-3(1)→(3)] → Washer tank [CN-22(2)→(1)] → Washer operation  
 ↳ I/conn [CN-6(1)] → I/conn [CN-13(1)] → Wiper motor operation [CN-21(1)]

#### (3) Auto-parking (when switch OFF)

Wiper & washer switch OFF [CS-3(8)→(6)] → Wiper motor [CN-21(1)] →  
 Fuse box(No.5) → I/conn [CN-36(6)] → I/conn [CN-6(2)] → I/conn [CN-13(3)] →  
 Wiper motor [CN-21(3)→(4)] → Wiper motor stop

### 2) CHECK POINT

Engine	Start switch	Check point	Voltage
STOP	ON	① - GND (Fuse box) ② - GND (Switch power input) ③ - GND (Switch power output) ④ - GND (Wiper power input) ⑤ - GND (Wiper power input) ⑥ - GND (Wiper motor) ⑦ - GND (Switch power output)	20 ~ 25V

※ GND : Ground

# WIPER AND WASHER CIRCUIT

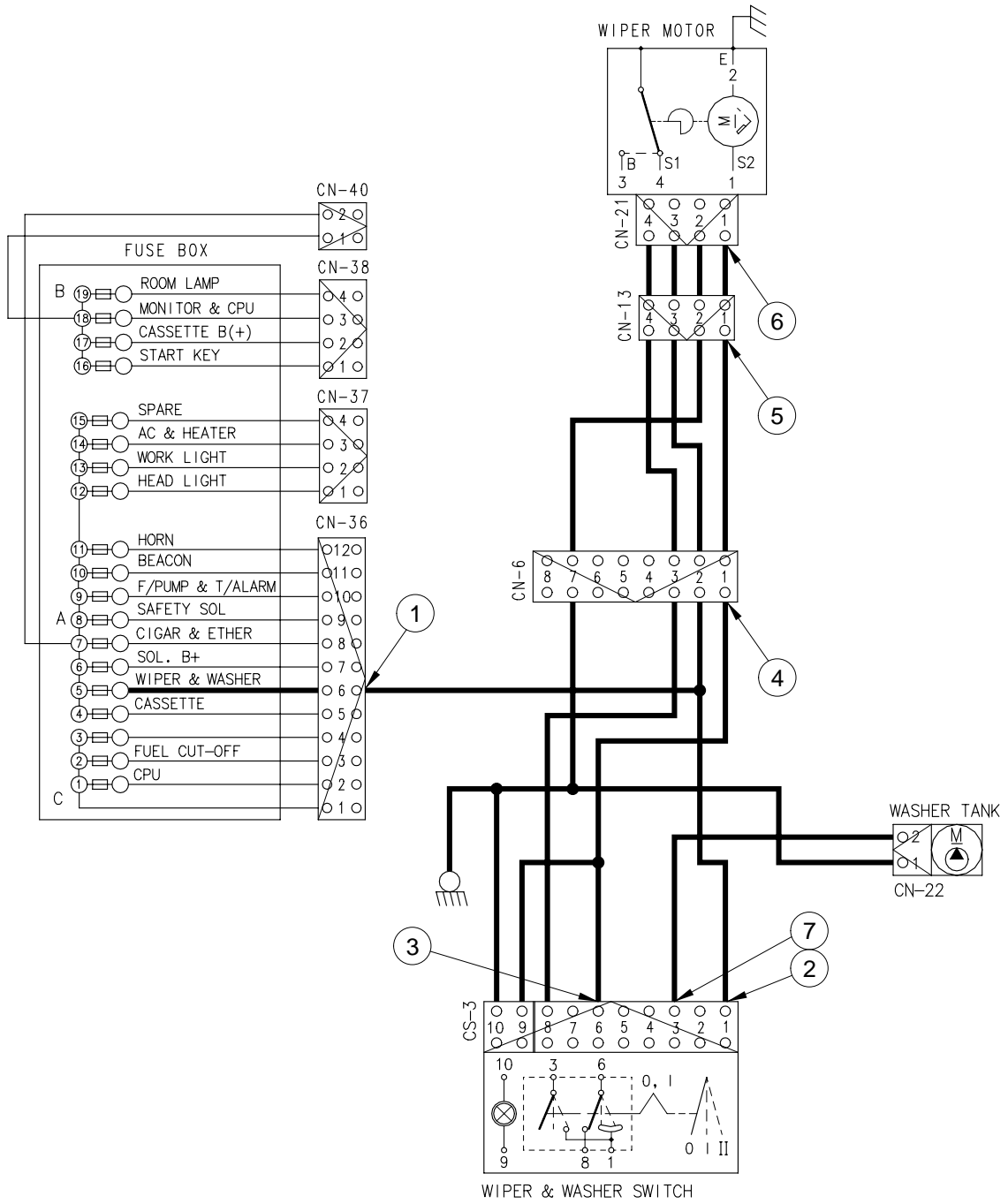

# CONTROLLER CIRCUIT

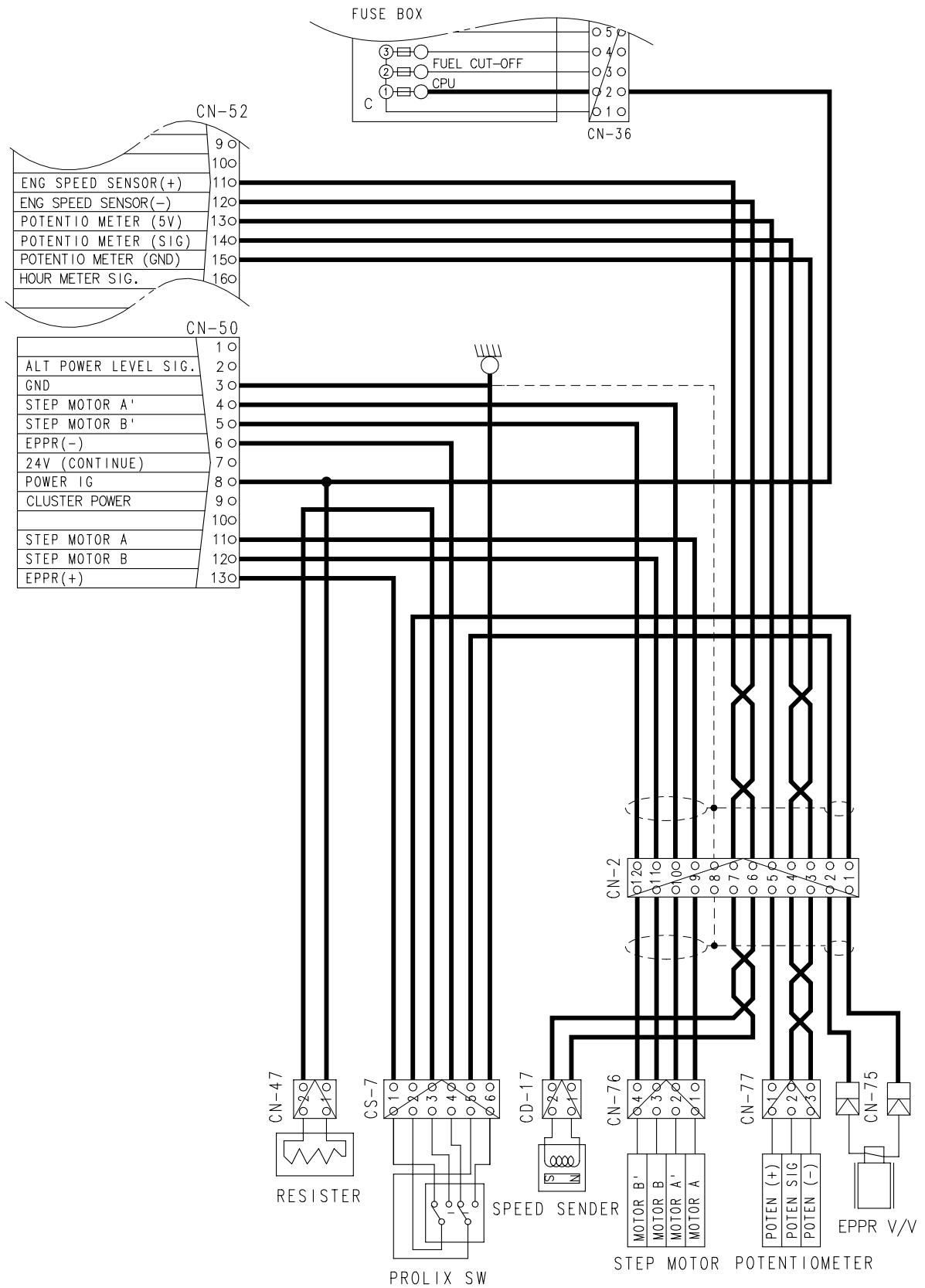

ELECTRIC CIRCUIT FOR HYDRAULIC

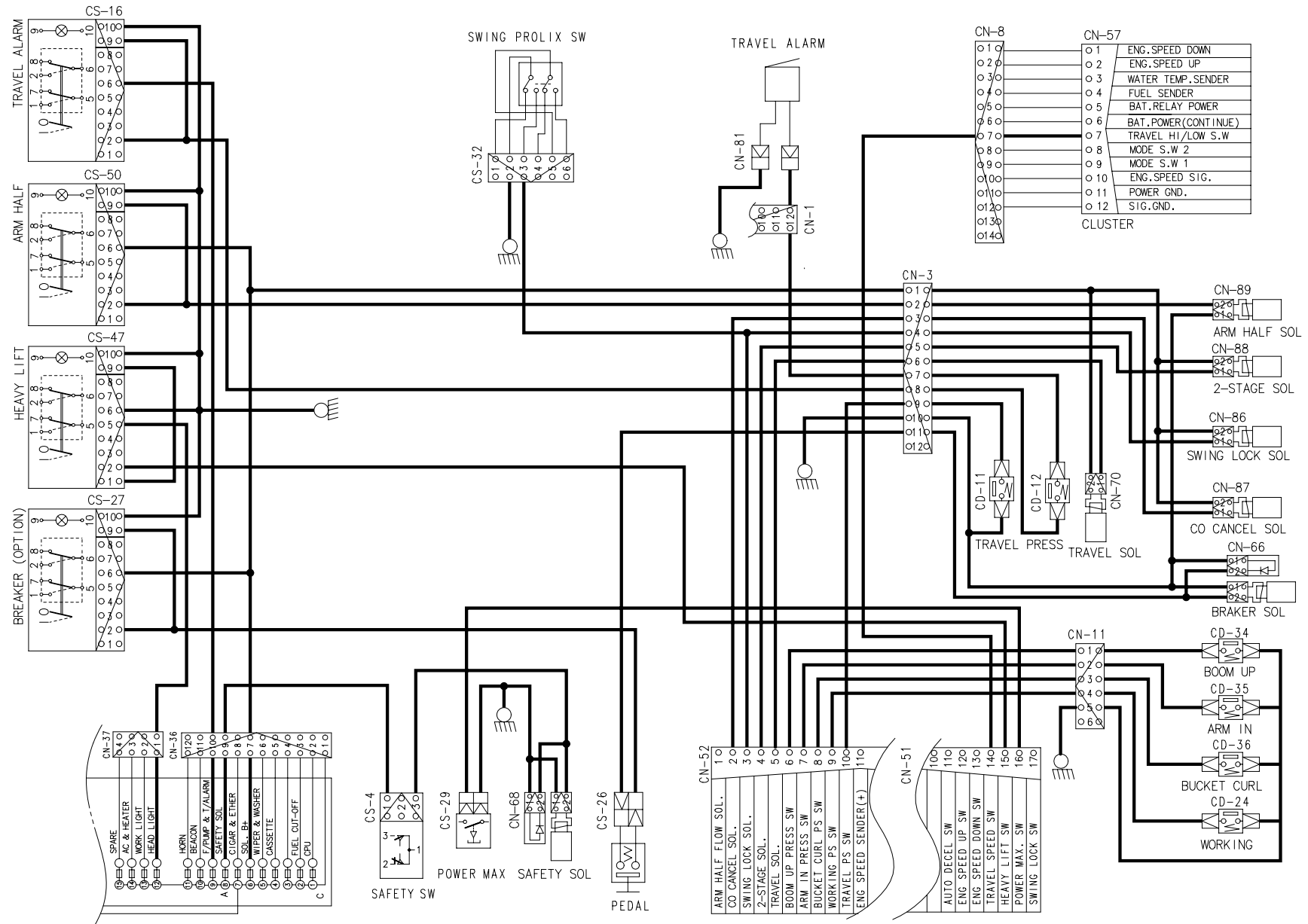

MONITORING CIRCUIT

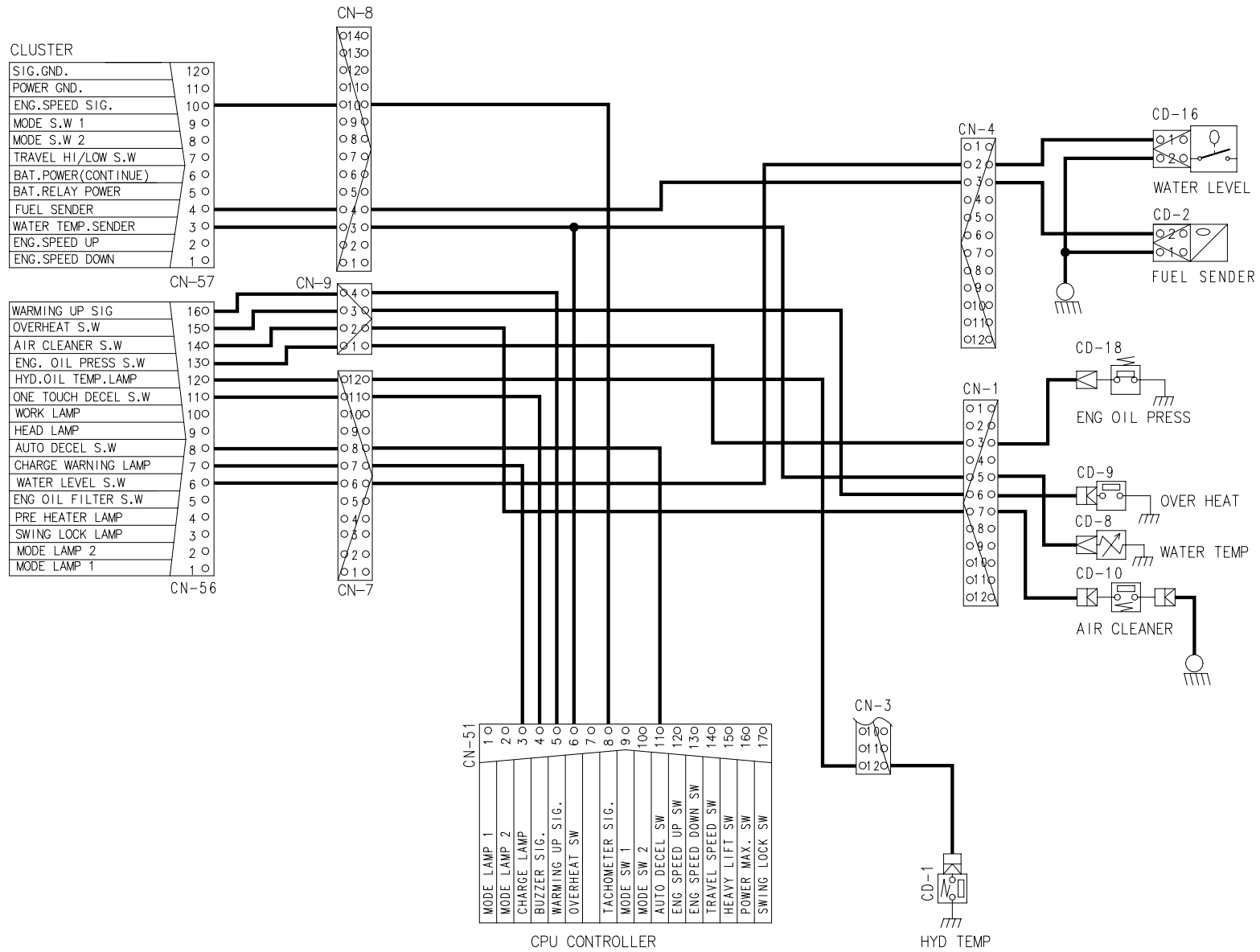



# CHARGING CIRCUIT

